



### GT2 Air Push Type

Air push models  
for stable operation  
with easy mounting.



## GT2 SERIES

Revolutionary technology enables high-precision measurement



[World's First!]

SCALE  
SHOT  
SYSTEM

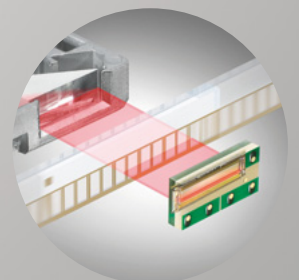
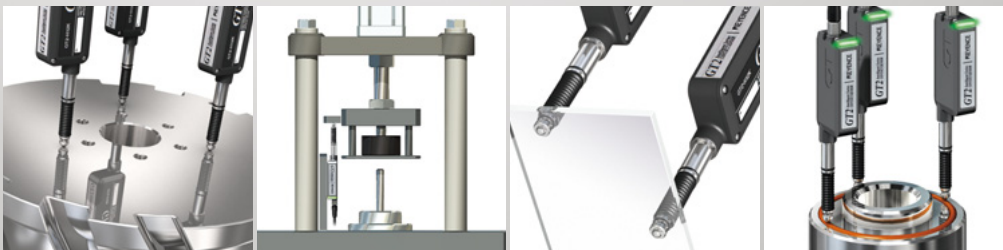

# New GT2 Series that provides higher precision while maintaining its No Error feature

Adopting the world-first, ground-breaking scale-shot system, the new GT2 Series provides high precision, without speed errors. The application of KEYENCE technologies brings the advent of the GT2 Series.

Formed through a prism  
LED parallel light  
illumination

Free from deformation  
Quartz glass scale

Detachable Cable

Approx. 6  $\mu$ s shutter speed  
CMOS sensor

**GT2** SERIES

## Advantages of the conventional scale method (pulse counting)

High accuracy in the entire measurement range  
Good temperature characteristics



## Advantages of the conventional transformer method

No tracking errors  
Absolute position detection



KEYENCE introduces new technology

World's first

## SCALE SHOT SYSTEM

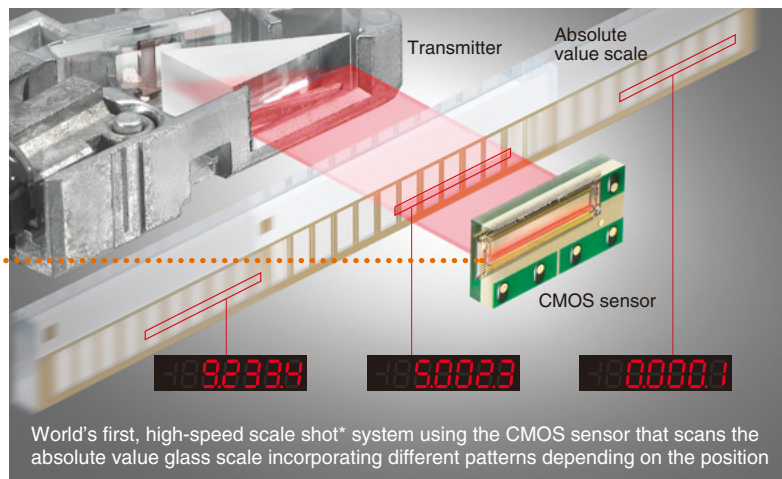

\* Shutter speed: Approx. 6  $\mu$ s, Shooting interval: 1 ms

## Highest precision in its class

Absolute system

Resolution

0.1  $\mu$ m

Accuracy

1  $\mu$ m

# Tough and Rugged

[ Maintenance cost reduction ]

## Long life

### Detecting durability: 20 million times\*

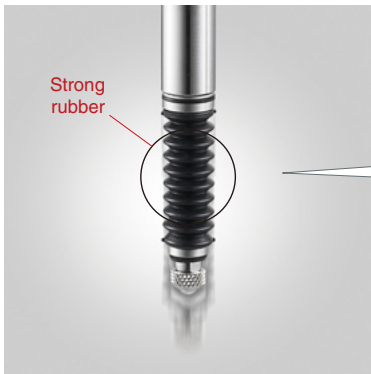

Linear ball bearings are used for the spindle to ensure long service life.

\* GT2-H12 (L/K/KL), Typical

## Water resistant cable

### IP67 enclosure rating



## Strong against bending

### Flexible free-cut robot cable

The sensor head cable uses a robot cable that withstands continuous bending.

- Load (W): 250 g
- Bend radius: 50 mm
- Bending rate: 30 times/minute  
(1 time includes left to right to original position)
- Free cut: can be cut to length

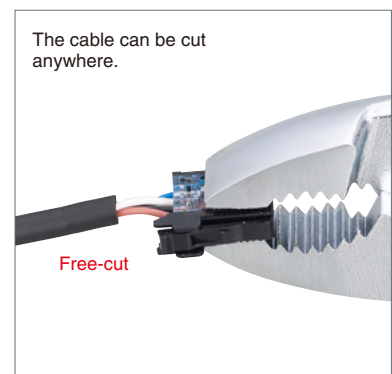
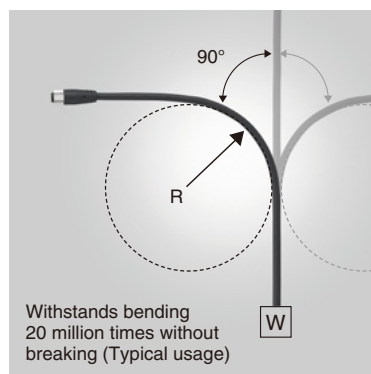

# Easy Sensor Head Installation and Setup

[ Reduction in the number of installation/setup steps ]

## Easy installation with a special bracket

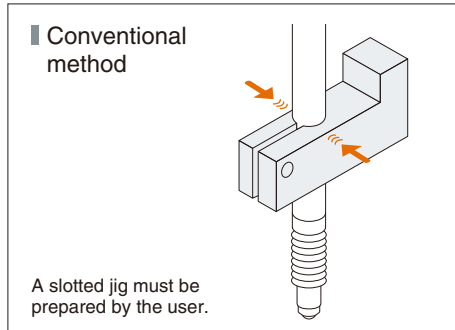

## Large indicators are convenient when setting up of several units.

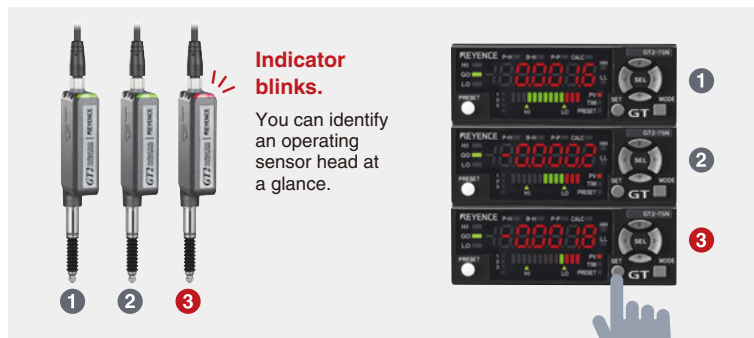

# Simple Tolerance Setting

[ Reduction in number of setting steps ]

First, set a reference.



Enter the tolerance value based on the master target to complete setup.



# Easy Amplifier Installation and Setup

[ Reduction in the number of installation/setup steps ]

Select the best display unit according to your needs.

## DIN-rail mount



**GT2-71N/71P**  
Easy mounting anywhere

## Compact, panel mount



**GT2-75N/75P**  
For mounting on a nearby wall

## Large display panel mount



**GT2-100N/100P**  
Easy-to-see large display

## Pulse output



**GT2-71D**  
For outputting position data as pulses

Note: For the DIN-rail mounting type, a connector type and an analogue output type are also available.

### Features of the large display type

#### Easy operation with large display and large buttons

Double the size of a standard display [Character height: 14 mm]  
Large display

Easy preset operation  
Large button



The selected ID number lights in red.

Easy selection with the dedicated button  
Sensor head selection button

Easy viewing of the OK/NG and connection status of each individual head connected at a glance. (OK/NG status is indicated by red or green, connecting status indicated by a blinking LED.)

W: 159.5 mm  
H: 79.8 mm

A single unit can connect several sensor heads (11 heads max.).

Power supply terminal block  
Standard I/O (20-pin MIL connector, male)

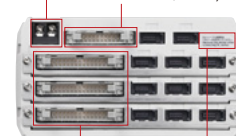

Expansion board I/O (30-pin MIL connector, male)  
Communication unit connection port connector, male

Installing the expansion board



The expansion board allows for connection of up to 11 sensor heads.

### Features of the pulse output (line driver output) type

#### Outputs the spindle position data

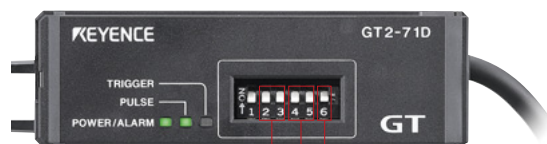

Pulse output amplifier unit  
**GT2-71D**

Increment/decrement direction

Resolution

Pulse width

#### Pulse frequency selection [10/50/100/500 kHz]

The maximum pulse frequency can be selected according to the input device. The absolute detection ensures accurate position data output to an external device without tracking errors even when a slow pulse frequency is selected.

All position data can be output together.

The absolute detection allows the output of all pulses from the origin to the measurement point without origin return at power-up. Moreover, the operation is tracking error free.

# Total cost reduction

[ Simplified setup eliminates need for analogue I/O cards and tedious PLC programming ]

Analogue I/O card not necessary

## No additional equipment required

Forget about the tedious PLC programming that you're used to with your existing LVDT's. The GT2 Series does the work for you. In addition, you can save money by eliminating the analogue I/O card from your budget.

### Conventional Method

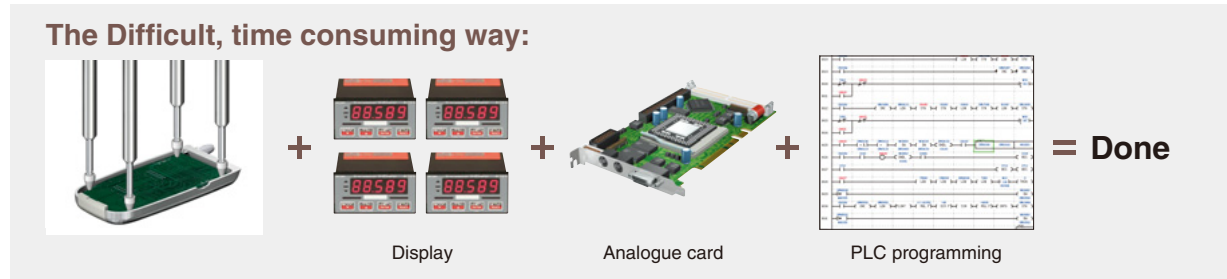

### GT2 Solution



Pushbutton setup

## HH, HI, GO, LO, LL discrete outputs

Featuring 5 digital comparator outputs (HH, HI, GO, LO and LL), the GT2 Series can be set up in minutes, not hours. Pushbutton calibration will leave you asking yourself why you hadn't switched to the GT2 Series sooner.

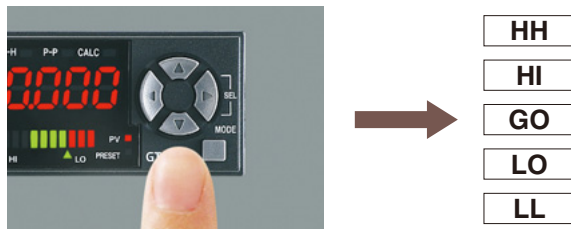

Quickly select from up to 4 sets of HH/HI/LO/LL limits

## Simple product changeover

Using channel select inputs on the GT2 Series, users can easily toggle between up to 4 different sets of HH/HI/LO/LL limits. You can even use your existing HMI, while skipping the PLC programming running behind the scenes.

# Detection of NG Condition

[ Current condition check ]

## Sensor defect detection

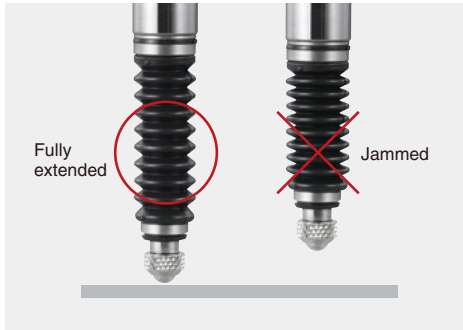

The sensor outputs for confirmation of jams and when the sensor head is fully extended.

## Equipment status check displayed by a bar indicator

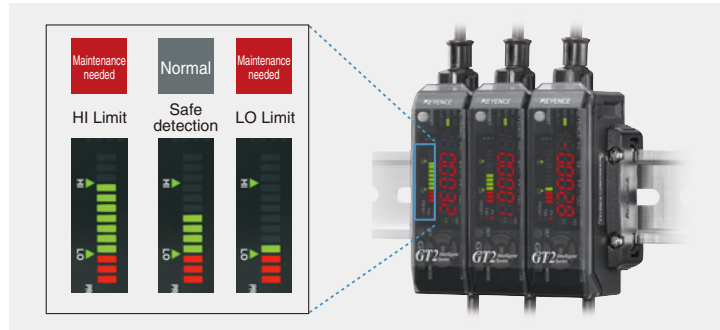

In actual operation, it is difficult to read a displayed value when it changes quickly. With the bar indicator the equipment status can be easily read without reading a displayed value.

# Calculations made simple

[ Reduction in number of setting steps ]

When several amplifiers are connected, the GT2 Series enables automatic calculation simply by selecting a calculation mode.

<p>Thickness</p>	<p>[Shaft diameter measurement]</p> <p>Positioning the target between two sensor heads will display the outer diameter.</p> <p>Main unit: 1000025 + Expansion unit: -00025 = Calculation result: 1000000</p>
<p>Degree of flatness</p>	<p>[Flatness check]</p> <p>By subtracting the minimum value from the maximum value the flatness will be displayed.</p> <p>Main unit: 06510 (Maximum value) - Expansion unit: 06423 (Minimum value) = Calculation result: 00087</p>
<p>Reference difference</p>	<p>[Determining pin height]</p> <p>The height difference of a reference value can be displayed by subtracting the value of the main unit (reference) from a value of the Expansion unit.</p> <p>Expansion unit: 50032 - Main unit: 50000 = Calculation result: 00032</p>
<p>Versatile detection modes support all applications</p> <p>Single head: STD (Standard), P-H (Peak hold), B-H (Bottom hold), P-P (Peak to peak)</p> <p>Multiple heads/when additional amplifier units are installed (Application modes): Maximum, Minimum, Degree of flatness, Average, Reference difference, Twist, Warp, Thickness</p>	

\* For details regarding the calculation modes, refer to P.30.

# Air push type extends the spindle and measures.

[ Easy to set up and saves space. ]

The air push type is part of the high-accuracy digital sensor GT2 Series.

A mechanism to move the sensor head is not necessary since it is possible to measure with a fixed sensor head which saves space and reduces labour-hours.



Jigs and mechanisms to move the sensor are no longer necessary.

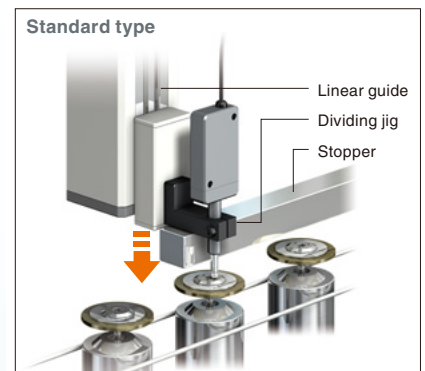

A complex jig is not necessary since there is no sensor head movement. In addition, errors in accuracy due to jigs have been eliminated.

Installation is quick and easy.

1 A dividing jig is unnecessary.



2 Air is supplied.



\*1 For the 32 mm and 50 mm type, open a  $\phi 14$  mm hole.

Point 1

Spindle compressed in its usual state

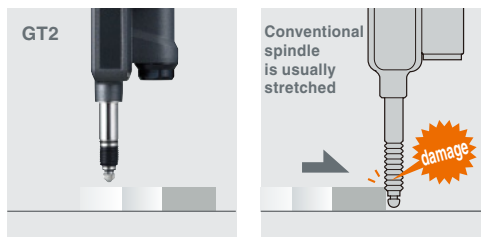

With the GT2, the spindle moves to the origin when it is not being supplied with air. Even if there is a problem or a condition arises where air is not being supplied, it is safe.

Point 2

Measuring force is unaffected by the amount of air pressure.



Due to the pressure free construction where air pressure is not directly applied to measurement parts, it is also safe to use with easily damaged workpieces.

# Versatile detection modes support all applications

## Single head

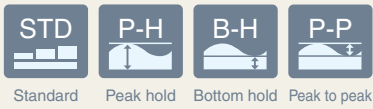

## Multiple heads

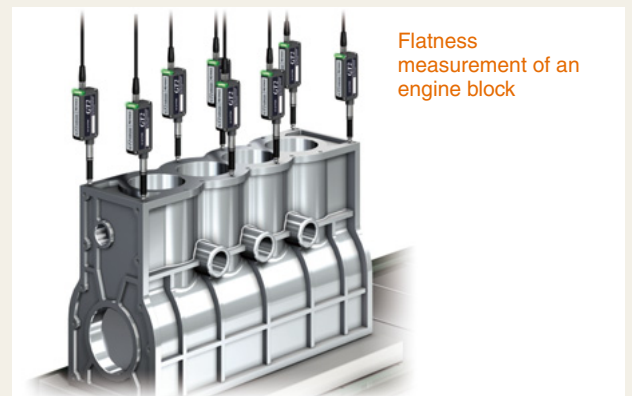
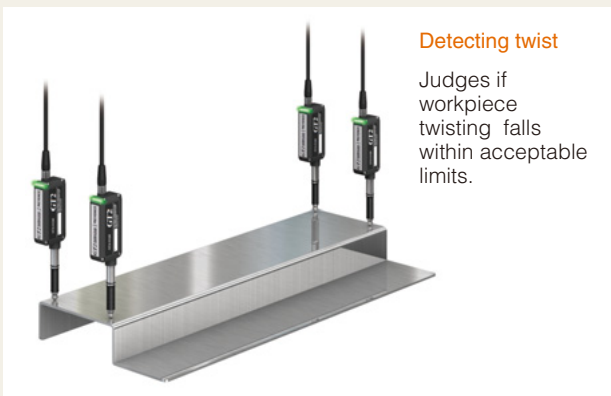
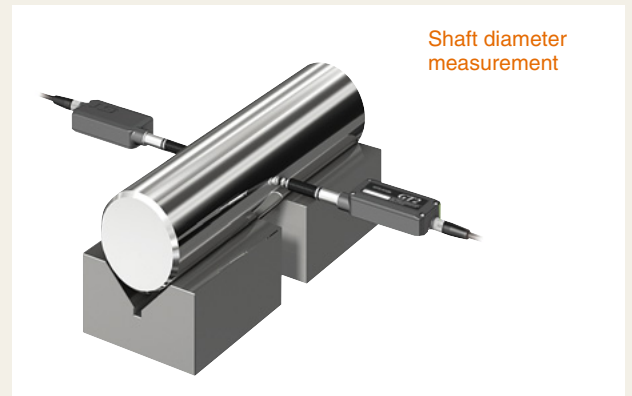
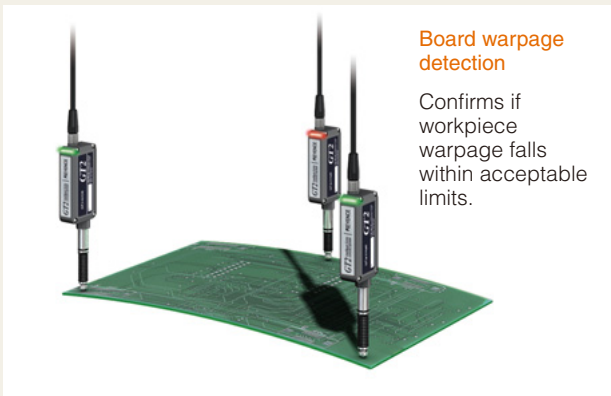
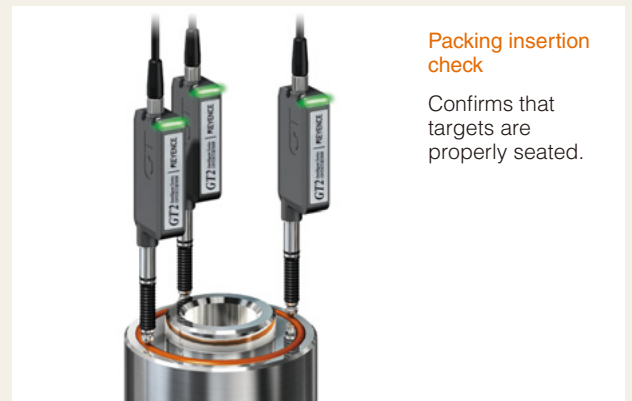
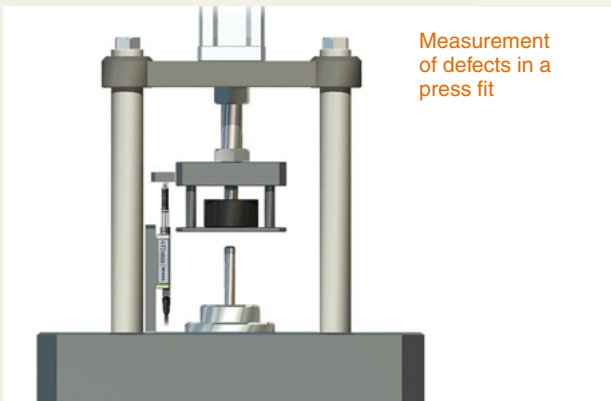
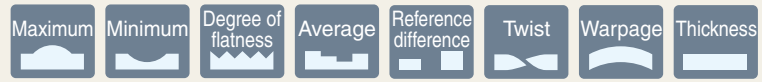



Thickness measurement of a liquid crystal substrate

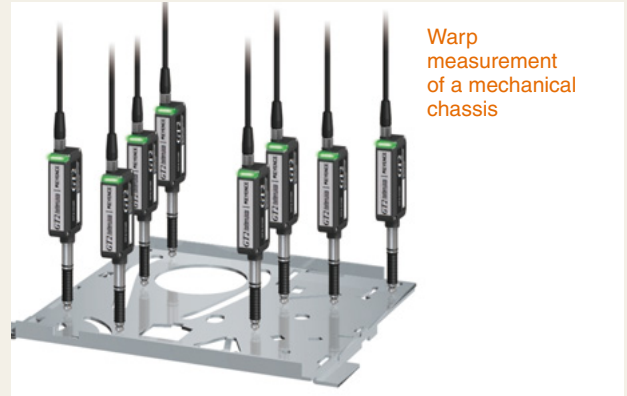

Warp measurement of a mechanical chassis

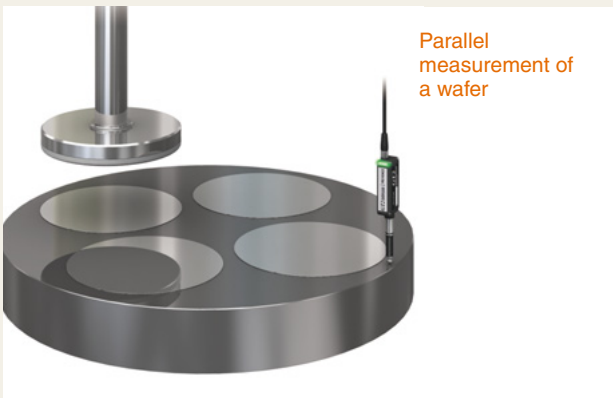

Parallel measurement of a wafer



Volume measurement of a cam lift

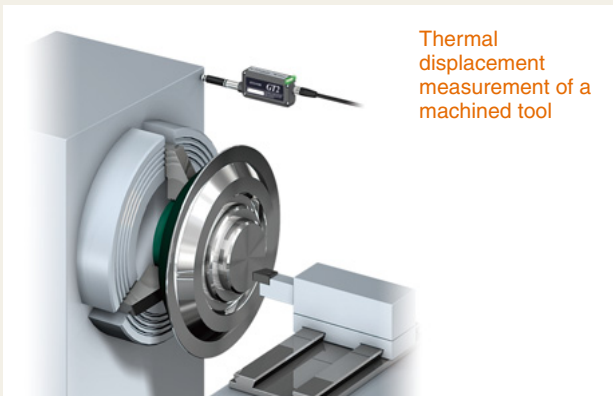

Thermal displacement measurement of a machined tool

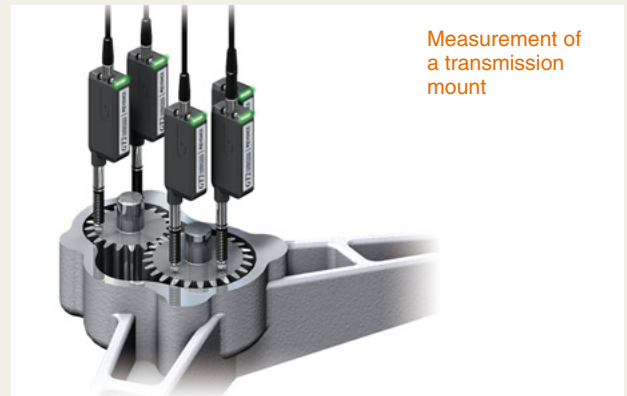

Measurement of a transmission mount



Thickness measurement of a steel plate



Detection of crank shaft defects

# How to select a GT2 Series sensor

Follow the steps below to select the GT2 Series sensor best suited to your operating environment from the wide range of units and accessories.



## GT2 Series LINE-UP

### step 1 Sensor head

#### Standard Type



12 mm range  
High-accuracy  
sensor head  
**GT2-H12K**



12 mm range  
High-accuracy,  
low stress sensor  
head  
**GT2-H12KL**



12 mm range  
General-purpose  
sensor head  
**GT2-H12**



12 mm range  
General-purpose,  
low stress sensor  
head  
**GT2-H12L**



32 mm range  
General-purpose  
sensor head  
**GT2-H32**



32 mm range  
General-purpose,  
low stress sensor  
head  
**GT2-H32L**



50 mm range  
General-purpose  
sensor head  
**GT2-H50**

#### Air push Type



12 mm range  
High-accuracy  
sensor head  
**GT2-A12K**



12 mm range  
High-accuracy,  
low stress sensor  
head  
**GT2-A12KL**



12 mm range  
General-purpose  
sensor head  
**GT2-A12**



12 mm range  
General-purpose,  
low stress sensor  
head  
**GT2-A12L**



32 mm range  
General-purpose  
sensor head  
**GT2-A32**



50 mm range  
General-purpose  
sensor head  
**GT2-A50**

### step 2 Sensor head cable



### step 3 Mounting bracket



### step 4 Display unit



DIN-rail mount type  
Amplifier unit  
**GT2-71N / 71P**



Panel mount type  
Compact amplifier  
unit  
**GT2-75N / 75P**



Panel mount type  
Large display  
amplifier unit  
**GT2-100N / 100P**



DIN-rail mount type  
Pulse output  
amplifier unit  
**GT2-71D**

### step 5 Display unit options



### step 6 Contact



### step 7 Communication unit



EtherNet/IP  
**DL-EP1**



DeviceNet  
**DL-DN1**



BCD Output unit  
**DL-RB1A**



RS-232C  
Communication  
unit  
**DL-RS1A**

### step 8 Communication unit options



step 1

# First, select a sensor head.

Required item

The sensor head is determined by the measuring range, the accuracy and the measuring force.

Commonly used type

## ▶ 12 mm range

For 20 μm or less tolerance differentiation

### ▶ High-precision Type

Resolution: 0.1 μm  
Accuracy: 1 μm (P-P)

- High-precision type sensor head  
**GT2-H12K**
- High-precision / Low stress type sensor head  
**GT2-H12KL**



When particularly high accuracy is not required

### ▶ General-purpose Type

Resolution: 0.5 μm  
Accuracy: 2 μm (P-P)

- General-purpose type sensor head  
**GT2-H12**
- General-purpose / Low stress type sensor head  
**GT2-H12L**



For a wider measuring range

## ▶ 32 mm range

Resolution: 0.5 μm  
Accuracy: 3 μm (P-P)

- General-purpose type sensor head  
**GT2-H32**
- General-purpose / Low stress type sensor head  
**GT2-H32L**



For a larger target

## ▶ 50 mm range

Resolution: 0.5 μm  
Accuracy: 3.5 μm (P-P)

- General-purpose type sensor head  
**GT2-H50**
- The low stress type is not available for the 50 mm range sensor head.



### What is the low stress type?

The low stress type provides no dust boot.

The low stress type uses a low repulsion force spring to reduce the pressure on the target. When using a target that can be easily deformed or damaged select this type.

Measuring range	Type of accuracy	Measuring force	Resolution	Accuracy	Measuring force*			Model
					Downward mounting	Side mounting	Upward mounting	
12 mm	High-precision	Standard	0.1 μm	1 μm	1.0 N	0.9 N	0.8 N	GT2-H12K
		Low stress			0.4 N	0.3 N	0.2 N	GT2-H12KL
	General-purpose	Standard	0.5 μm	2 μm	1.0 N	0.9 N	0.8 N	GT2-H12
		Low stress			0.4 N	0.3 N	0.2 N	GT2-H12L
32 mm	General-purpose	Standard	0.5 μm	3 μm	2.1 N	1.8 N	1.5 N	GT2-H32
		Low stress			1.2 N	0.9 N	0.6 N	GT2-H32L
		Standard			3.2 N	2.8 N	2.4 N	GT2-H50
50 mm	General-purpose	Standard	0.5 μm	3.5 μm	3.2 N	2.8 N	2.4 N	GT2-H50

\* Value at centre of measuring range.

Dust boot (optional accessory for replacement)

Appearance	Applicable sensor head	Model
	GT2-H12	OP-84332
	GT2-H12K	OP-84459
	GT2-H32	OP-84459
	GT2-H50	OP-84460

# Air Push Type

Commonly used type

## ▶ 12 mm range

For 20 µm or less tolerance differentiation

### ▶ High-accuracy Type

Resolution: 0.1 µm  
Accuracy: 1 µm (P-P)

- High-accuracy type sensor head  
**GT2-A12K**
- High-accuracy / Low stress type sensor head  
**GT2-A12KL**



Low stress type

When particularly high-accuracy is not required

### ▶ General-purpose Type

Resolution: 0.5 µm  
Accuracy: 2 µm (P-P)

- General-purpose type sensor head  
**GT2-A12**
- General-purpose / Low stress type sensor head  
**GT2-A12L**



Low stress type

For a wider measuring range

## ▶ 32 mm range

Resolution: 0.5 µm  
Accuracy: 3 µm (P-P)

- General-purpose type sensor head  
**GT2-A32**
- The low stress type is not available for the 32 mm range sensor head.



For a larger target

## ▶ 50 mm range

Resolution: 0.5 µm  
Accuracy: 3.5 µm (P-P)

- General-purpose type sensor head  
**GT2-A50**
- The low stress type is not available for the 50 mm range sensor head.



Measuring range	Type of accuracy	Measuring force	Resolution	Accuracy	Measuring force*			Model
					Downward mounting	Side mounting	Upward mounting	
12 mm	High-accuracy	Standard	0.1 µm	1 µm	1.2 N	1.1 N	1.0 N	GT2-A12K
		Low stress			0.4 N	0.3 N	0.2 N	GT2-A12KL
	General-purpose	Standard	0.5 µm	2 µm	1.2 N	1.1 N	1.0 N	GT2-A12
		Low stress			0.4 N	0.3 N	0.2 N	GT2-A12L
32 mm	General-purpose	Standard	0.5 µm	3 µm	2.1 N	1.8 N	1.5 N	GT2-A32
50 mm		Standard		3.5 µm	3.2 N	2.8 N	2.4 N	GT2-A50

\* Value at centre of measuring range.

## Adjustable spindle speed

The speed controller (optional) allows the spindle movement speed to be adjusted.



Speed controller  
**OP-82133**

step 2

## Select a sensor head cable. Required item

Select the sensor head cable according to installation conditions and the distance between the sensor head and the display unit (amplifier). The L-shaped type can be used for the 12 mm range sensor head (GT2-H12/A12) only.

Commonly used type

### ▶ Straight Type



Cable connection



For space-saving installation

### ▶ L-shaped Type



Cable connection



This connector does not rotate. It is fixed in the direction as shown in the photo (left).

Type	Appearance	Cable length	Model	Weight
Straight		2 m	GT2-CH2M	Approx. 80 g
		5 m	GT2-CH5M	Approx. 190 g
		10 m	GT2-CH10M	Approx. 360 g
		20 m	GT2-CH20M	Approx. 680 g
L-shaped Applicable to 12 mm range type only		2 m	GT2-CHL2M	Approx. 80 g
		5 m	GT2-CHL5M	Approx. 190 g
		10 m	GT2-CHL10M	Approx. 360 g
		20 m	GT2-CHL20M	Approx. 680 g

The cable can be freely cut. If the cable is cut, a connector (OP-84338) is required to connect to the display unit (amplifier).

This connector is required if the cable is cut.

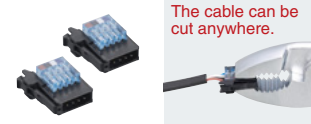

The cable can be cut anywhere.

Connector used to connect to a display unit (2 pcs.) OP-84338

step 3

## Select mounting brackets as required.

Select a mounting bracket depending on the sensor head mounting method.

### ▶ For GT2 12 mm range models

Commonly used type

#### ▶ Mounting Bracket A



OP-76874

Vibration resistant, Reinforced holding force

#### ▶ Mounting Bracket C



OP-84396

For side mounting

#### ▶ Mounting Bracket B



OP-76875

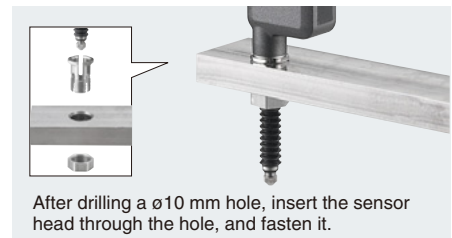

After drilling a  $\phi 10$  mm hole, insert the sensor head through the hole, and fasten it.



Horizontally mounts the sensor head.

### ▶ For GT2 32 mm and 50 mm range models

Vibration resistant, Reinforced holding force

#### ▶ Mounting Bracket D



OP-84327

After drilling a  $\phi 14$  mm hole, insert the sensor head through the hole and fasten it.

\* The mounting method is the same as mounting brackets A and C.  
\* When using the GT2-H32L with its contact probe directing upward, use the mounting hole of the main unit.

step 4

# Next, select a display unit (amplifier).

Required item

After selecting a display unit depending on the mounting method, select an optional accessories as required.

Easy installation in any place

## DIN-rail Mount Type

Commonly used type

### Loose wire type



GT2-71N/71P

Easy installation/replacement

### Connector type



GT2-71CN/71CP

Type			Model		
			NPN output	PNP output	Line driver output
Loose wire	Standard	Main unit	GT2-71N	GT2-71P	-
		Expansion unit	GT2-72N	GT2-72P	
	Pulse output		-	-	GT2-71D
Connector*	Standard	Main unit	GT2-71CN	GT2-71CP	-
	Analogue		GT2-71MCN	GT2-71MCP	
	Standard	Expansion unit	GT2-72CN	GT2-72CP	

\* When the connector type amplifier unit is used, an optional socket cable should be purchased separately (See the next page.).

### Connecting additional expansion units

Use the connector on the side of the unit.

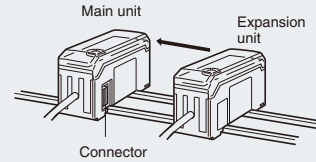

To connect an additional unit, purchase the optional end unit (OP-26751).

For each main unit, up to 14 expansion units can be connected. When several units are connected, a power supply cable is not required for the expansion units. The GT2 Series can be connected with the GT Series. In this case, however, the maximum number of connectable units is 10 units (including main unit). Unit expansion is not possible for the GT2-71D.

The analogue output type amplifier unit provides three discrete outputs.

Installation on easy-to-see places (walls, etc.)

## Panel Mount Type

Commonly used type

### Compact type



GT2-75N/75P  
W: 66 mm H: 23.9 mm

Easy-to-see display for easier operation

### Large display type



GT2-100N/100P  
W: 159.5 mm H: 79.8 mm

Type		Model	
		NPN output	PNP output
Compact	Main unit	GT2-75N	GT2-75P
	Expansion unit	GT2-76N	GT2-76P
Large display*		GT2-100N	GT2-100P

\* When these amplifier units are not mounted to a panel, an optional mounting bracket should be purchased separately (See the next page.).

### Connecting additional main and expansion units [Compact type only]

Connect using the cable supplied with the expansion unit.

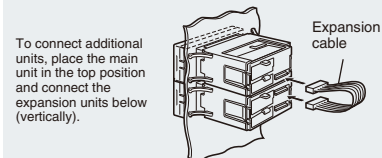

To connect additional units, place the main unit in the top position and connect the expansion units below (vertically).

\* For horizontal installation, the optional expansion cable (OP-35361, 300 mm) is required. For details, refer to the description in the option list.

For the compact type amplifier unit, up to 14 expansion units can be connected to one main unit without providing power supply cables individually. The expansion connection can include the GT Series, however, the maximum number of connectable units is limited to 10 including the main unit.





A single unit of the large display type can connect two sensor heads. When the optional expansion boards are used, up to 11 sensor heads can be connected. For the details of the expansion board, see the next page.

**step 5**

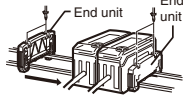

## Select the optional accessories for the display unit as required.

Select the optional accessories according to the display unit selected in Step 4.



### ▶ Optional accessories for the GT2-71/72 (DIN-rail mount)

Type	Description	Model
<p>For installation without a DIN-rail</p> <p>▶ <b>Mounting Bracket for DIN-rail mount Type Display unit</b> (optional accessory for main unit)</p> 	<p>The amplifier can be mounted without using a DIN-rail.</p>  <p>Amplifier mounting bracket</p>	OP-76877
<p>Required for connecting additional units</p> <p>▶ <b>End unit</b> (Optional)</p> 	<p>To connect an additional expansion unit, use the end units to secure the display units on both ends. When connecting additional units, be sure to use the end units. (2 pcs.)</p> 	OP-26751
<p>Required when the connector type is used</p> <p>▶ <b>Socket cable 2 m/10 m</b> (Optional)</p> 	<p>Used to connect the connector type display unit. Since the amplifier unit does not include the socket cable, it should be purchased together.</p>	GT2-CA2M (2 m) GT2-CA10M (10 m)

### ▶ Optional accessories for the GT2-75/76 (panel mount, compact)





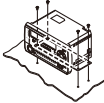





Type	Description	Model
<p>Standard equipment – Normally, not required</p> <p>▶ <b>Panel mounting bracket</b> (Included in panel mount type amplifier)</p> 	<p>The panel mounting bracket is included in the panel mount type amplifier. If the supplied bracket is lost or damaged, order a new bracket.</p>	OP-84394
<p>If the standard cable length is not enough</p> <p>▶ <b>Expansion cable: 300 mm</b> (Optional)</p> 	<p>Extension cable used for panel mount type amplifier. Use this cable if the standard 50 mm cable is not long enough. Up to 4 extension cables can be used at once. However, if an extension cable is used, the number of expansion units that can be connected to a single main unit is limited to 4 units.</p>	OP-35361

### ▶ Optional accessories for the GT2-100 (panel mount, large display)

Type	Description	Model										
<p>To connect three or more sensor heads</p> <p>▶ <b>Expansion board</b> For GT2-100N (Optional) For GT2-100P (Optional)</p> 	<p>Installing this expansion board into the GT2-100 allows you to connect more than two sensor heads. Since one expansion board allows connection of one to three sensor heads, the maximum of 11 sensor heads can be connected in total.</p> <table border="1" data-bbox="1141 1518 1353 1630"> <thead> <tr> <th>No. of sensor heads</th> <th>No. of expansion boards</th> </tr> </thead> <tbody> <tr> <td>1 or 2</td> <td>None</td> </tr> <tr> <td>3 to 5</td> <td>1</td> </tr> <tr> <td>6 to 8</td> <td>2</td> </tr> <tr> <td>9 to 11</td> <td>3</td> </tr> </tbody> </table>	No. of sensor heads	No. of expansion boards	1 or 2	None	3 to 5	1	6 to 8	2	9 to 11	3	GT2-E3N (NPN) GT2-E3P (PNP)
No. of sensor heads	No. of expansion boards											
1 or 2	None											
3 to 5	1											
6 to 8	2											
9 to 11	3											
<p>To install the GT2-100 on a workbench, etc.</p> <p>▶ <b>Mounting bracket</b> (Optional)</p> 	<p>When the amplifier unit is not mounted to a panel, use this mounting bracket to secure it.</p> 	OP-84331										
<p>I/O connector</p> <p>▶ <b>20-pin MIL connector</b> (for the amplifier unit, optional) <b>30-pin MIL connector</b> (for the expansion board, optional)</p>	<p>A set of a connector and contacts (for AWG 24 to 22). The cable should be prepared by the user.</p>	OP-22185 (20-pin) OP-84456 (30-pin)										
▶ <b>Contact for maintenance work</b> (Optional)	For AWG 24 to 22, Package of 200	OP-22186										
▶ <b>Small diameter contact</b> (Optional)	For AWG 28 to 26, Package of 200	OP-30594										
▶ <b>Special crimping tool</b> (Optional)	Use this tool to crimp the contact.	OP-21734										

## step 6 Select a contact as needed.

The standard type and carbide type contacts are included in the GT2-H12 (L) / H32 (L) / H50 / A12 (L) / A32 / A50 and the GT2-H12K (L) / A12K (L) respectively, as standard equipment. Other types of contacts are optionally available. Select optional contacts as required.

<p>For standard measurement</p> <p><b>Standard</b> OP-77678</p>  <p>Standard equipment of general-purpose type sensor head GT2-H12 (L) / H32 (L) / H50 / A12 (L) / A32 / A50</p>	<p>Made from a carbide alloy – For high-precision measurement</p> <p><b>Super-tough</b> OP-77682</p>  <p>Standard equipment of high-precision type sensor head GT2-H12K (L) / A12K (L)</p>	<p>For targets with curved surfaces</p> <p><b>Flat Plate</b> (Optional) OP-77679</p>  <p>Ignore the contours of a target with a curved surface.</p>
<p>For moving targets</p> <p><b>Roller</b> (Optional) OP-77680</p>  <p>The roller smoothly detects moving targets.</p>	<p>To prevent damage to target</p> <p><b>Fluorocarbon Resin</b> (Optional) OP-80228</p>  <p>Made from material that is unlikely to damage the target's surface.</p>	<p>Electrically insulated from the target</p> <p><b>Ceramic</b> (Optional) OP-81970</p>  <p>A ceramic is used for the ball of the contact tip.</p>
<p>For measurement in narrow spaces</p> <p><b>Needle</b> (Optional) OP-77681</p>  <p>The needle contact is made of super-tough tungsten alloy.</p>	<p>For measurement at several points with small targets</p> <p><b>Offset</b> (Optional) OP-77683</p>  <p>Detecting points can be added in narrow range.</p>	<p>For 12.2 mm spindle extension</p> <p><b>Spacer</b> (Optional) OP-77684</p> 
		<p>When lifting a spindle by hand</p> <p><b>Lift lever</b> (Optional) OP-84397</p> 

## step 7 Select a communication unit as needed.

A communication unit is required to extract numerical data from the GT2 Series to an external device. With a single unit, data from up to 15 GT2 Series units can be extracted.

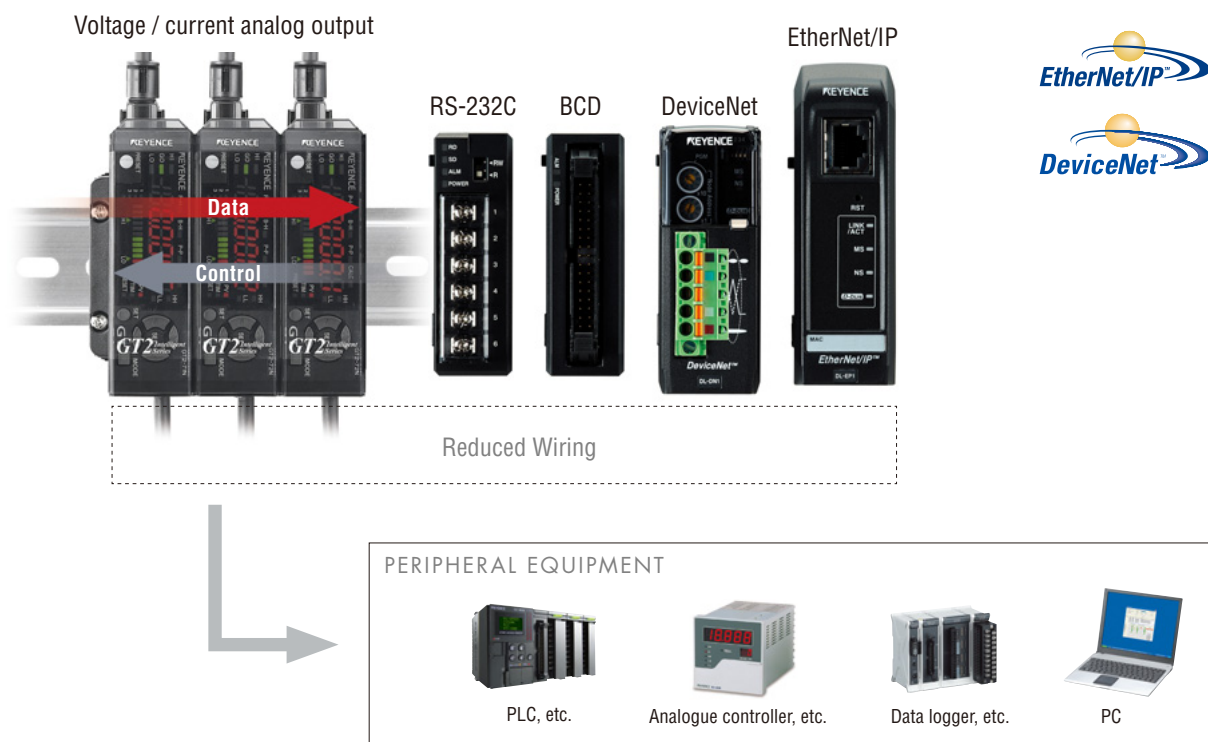

COMMUNICATION UNIT VARIATIONS



	<p><b>DL-EP1</b> EtherNet/IP Unit</p>  <p>Cyclic communication makes live data acquisition easy. In addition, message communications allows easy setting changes.</p>		<p><b>DL-DN1</b> DeviceNet Unit</p>  <p>Cyclic I/O Communication makes status monitoring simple. In addition, Explicit Messaging capability allows easy setting changes.</p>
	<p><b>DL-RS1A</b> RS-232C Unit</p> <p>RS-232C communication protocol allows universal compatibility with any device capable of decoding ASCII communications.</p>		<p><b>DL-RB1A</b> BCD Output Unit</p> <p>The measured value can be synchronized with a trigger input or updated via a timer. Output values are synchronized with the strobe output.</p>

step 8

Select the optional accessories for the communication unit as necessary.

Select the optional accessories according to the type of the communication unit selected in Step 7.

Optional accessories common to the DL-RB1A and DL-RS1A

Type	Description	Model		
<p>To install the unit without using a DIN-rail</p> <p><b>Fixing bracket</b></p>		<p>The communication unit can be mounted without using a DIN-rail.</p>	<p>OP-60412</p>	
<p>To connect the unit to the panel mount type display unit</p> <p><b>Expansion cable: 300 mm</b> (Optional)</p>		<p>Although the DL Series is designed for DIN-rail mounting only, the optional expansion cable (OP-35361, 300 mm) enables communication with the panel mount type amplifier unit (compact/ large display).</p>	 <p>OP-35361</p>	<p>OP-35361</p>







Optional accessories for the DL-RB1A

Type	Description	Model	
<p>I/O connector</p> <p><b>34-pin vertical MIL connector</b> (Optional) [40 contacts for AWG 24 to 22 included]</p>	<p>A set of a connector and contacts (for AWG 24 to 22). The cable should be prepared by the user.</p>	<p>OP-23139</p>	
<p>I/O connector</p> <p><b>34-pin slanting MIL connector</b> (Optional) [40 contacts for AWG 24 to 22 and a cable tie included]</p>	<p>A set of a connector and contacts (for AWG 24 to 22). The cable should be prepared by the user.</p>	<p>OP-42224</p>	
<p><b>Special crimping tool</b> (Optional)</p>		<p>Use this tool to crimp the contact.</p>	<p>OP-21734</p>
<p><b>Contact for maintenance work</b> (Optional)</p>	<p>For AWG 24 to 22, Package of 200</p>	<p>OP-22186</p>	
<p><b>Small diameter contact</b> (Optional)</p>	<p>For AWG 28 to 26, Package of 200</p>	<p>OP-30594</p>	

Optional accessories for the DL-RS1A

Type	Description	Model
<p><b>D-sub 9-pin connector-to-loose wires cable</b> (5 m, optional)</p>	<p>This cable can be used to connect the DL-RS1A to a personal computer or other serial device.</p>	<p>OP-81283</p>

### Sensor heads for the GT2 Standard Type







Model	GT2-H12K	GT2-H12KL	GT2-H12	GT2-H12L	GT2-H32	GT2-H32L	GT2-H50	
Type	Standard / Low stress (L) type (Sensor head for 12 mm)				Standard / Low stress (L) type (Sensor head for 32 mm / 50 mm range)			
Appearance								
Detection system	Quartz glass scale, CMOS image sensor projection system, Absolute type (without tracking error)							
Measuring range	12 mm				32 mm		50 mm	
Resolution	0.1 µm			0.5 µm				
Accuracy (20°C)	1 µm (p-p)		2 µm (p-p)		3 µm (p-p)		3.5 µm (p-p)	
Measuring force *1	Downward mounting	1.0 N	0.4 N	1.0 N	0.4 N	2.1 N	1.2 N	3.2 N
	Side mounting	0.9 N	0.3 N	0.9 N	0.3 N	1.8 N	0.9 N	2.8 N
	Upward mounting	0.8 N	0.2 N	0.8 N	0.2 N	1.5 N	0.6 N	2.4 N
Mechanical response	10 Hz	4 Hz	10 Hz	4 Hz	6 Hz	5 Hz	7 Hz	
Probe	Carbide ball ø3			Steel ball ø3				
Operation indicator	2-colour LED (red, green)							
Environmental resistance	Enclosure rating	IP67	–	IP67	–	IP67	–	IP67
	Ambient temperature	-10 to +55°C						
	Relative humidity	35 to 85% RH (No condensation)						
Vibration	10 to 55 Hz, 1.5 mm double amplitude, 2 hours in each of X, Y, and Z directions							
Sensor head cable	Optional (M8 connector)							
Materials	Main body	Main body cast: Zinc die-casting, Indicator: Polyarylate, Dust boot: NBR *2						
	Contact	TYPE304 Stainless steel, super-tough tungsten alloy			TYPE304, 440C Stainless steel			
Weight (excluding cable)	Approx. 95 g				Approx. 270 g		Approx. 320 g	
Accessories	Refer to the instruction manual.							

\*1 Value at centre of measuring range.

Please note that the measurement force changes depending on the installation state of the dust boots.

\*2 A dust boot is not provided with the GT2-H12KL, the GT2-H12L or the GT2-H32L.

### Sensor heads for the GT2 Air Push Type

Model	GT2-A12K	GT2-A12KL	GT2-A12	GT2-A12L	GT2-A32	GT2-A50	
Type	Standard / Low stress (L) type (Sensor head for 12 mm)				Standard type (Sensor head for 32 mm/50 mm range)		
Appearance							
Detection system	Quartz glass scale, CMOS image sensor projection system, Absolute type (without tracking error)						
Measuring range	12 mm				32 mm		50 mm
Resolution	0.1 µm			0.5 µm			
Accuracy (20°C) *1	1 µm (p-p)		2 µm (p-p)		3 µm (p-p)		3.5 µm (p-p)
Measuring force *2	Downward mounting	1.2 N	0.4 N	1.2 N	0.4 N	2.1 N	3.2 N
	Side mounting	1.1 N	0.3 N	1.1 N	0.3 N	1.8 N	2.8 N
	Upward mounting	1.0 N	0.2 N	1.0 N	0.2 N	1.5 N	2.4 N
Operation indicator	2-colour LED (red, green)						
Applied pressure range	0.25 to 0.5 MPa						
Pressure resistance	1.0 MPa						
Environmental resistance	Enclosure rating	IP67 *3	–	IP67 *3	–	IP67 *3	IP67 *3
	Ambient temperature	0 to 55°C					
	Relative humidity	35 to 85% RH (No condensation)					
Vibration *4	10 to 55 Hz, 1.5 mm double amplitude, 2 hours in each of X, Y, and Z directions						
Sensor head cable	Optional (M8 connector)						
Materials	Main body	Main body case: Zinc die-casting; Cylinder part: Aluminium alloy; Air joint resin part: Polyacetal; Air joint metal part: Brass nickel plating; Indicator: Polyarylate					
	Dust boot	NBR	–	NBR	–	NBR	NBR
	Contact *5	TYPE304 Stainless steel, super-tough tungsten alloy			TYPE304, 440C Stainless steel		
Weight (excluding cable)	Approx. 145 g				Approx. 340 g		Approx. 405 g
Accessories	Refer to the instruction manual.						

\*1 Value when ambient temperature is 20°C

\*2 Value at centre of measuring range.

Please note that the measurement force changes depending on the installation state of the dust boots.

\*3 Make sure the air tube is connected to the air exhaust joint and that no foreign materials enter inside from the joint.

\*4 In the case where a mounting bracket D is used with GT2-A32 and GT2-A50, the double amplitude becomes 0.75 mm.

\*5 The contact is included with the sensor.

## I DIN-rail mount type amplifier unit (For the pulse output type, see page 22.)

Model	NPN output	GT2-71N	GT2-72N	GT2-71CN	GT2-72CN	GT2-71MCN
	PNP output	GT2-71P	GT2-72P	GT2-71CP	GT2-72CP	GT2-71MCP
Mounting method	DIN-rail mount					
Type	Standard loose wire type			Standard connector type		Analogue output, connector type
Main unit / Expansion unit *1	Main unit	Expansion unit		Main unit	Expansion unit	Main unit
Appearance						
Power supply voltage *1	10 to 30 VDC, including 10% ripple (P-P)					20 to 30 VDC, including 10% ripple (P-P)
Power consumption *2	Normal	2200 mW max. (30 V, 73.3 mA max.)				2700 mW max. (30 V, 90 mA max.)
	Power saving (Eco)	1700 mW max. (30 V, 56.7 mA max.)				2200 mW max. (30 V, 73.3 mA max.)
Display power	Measured value display	6 + 1/2-digit 7-segment LED (red)				
	Other displays	2-colour, 13-level bar LED display (red, green), indicators (red, green)				
Display range	-199.999.9 to 199.999.9					
Display resolution	0.1 μm					
Sampling rate	1000 times/sec.					
Control input	Timing input	Input time: 2 ms min.				
	Preset input					
	Reset input					
	Bank input	Input time: 20 ms min.				
Control output	HH / High / Go / low / LL	NPN/PNP open collector, non-voltage output. Applicable current: 50 mA, Maximum applicable voltage (NPN: 40 V, PNP: 30 V) Residual voltage at ON: 1 V max. * N.O./N.C switchable (GT2-71MCN/71MCP: HH and LL are not available.)				
Analogue output	-				4 to 20 mA, maximum load resistance: 350 Ω Analogue output range can be changed as desired.	
Response time	hsp (3 ms), 5 ms, 10 ms, 100 ms, 500 ms, 1 s					
Environmental resistance	Ambient temperature	-10 to +50°C (GT2-71MCN/71MCP: -10 to +45°C when expansion unit(s) is connected)				
	Relative humidity	35 to 85% RH (No condensation)				
	Vibration	10 to 55 Hz, 1.5 mm double amplitude, 2 hours in each of X, Y, and Z directions				
Materials	Main body case: Polycarbonate, Key top: Polyacetal, Front sheet: PET, Cable: PVC					
Weight	GT2-71N/71P/72N/72P: Approx. 140 g (including power cable), GT2-71CN/71CP/72CN/72CP/71MCN/71MCP: Approx. 70 g					
Accessories	GT2-71N/71P/71CN/71CP/71MCN/71MCP: Instruction manual, Cover seal, GT2-72N/72P/72CN/72CP: None					

## I Panel mount type amplifier unit

Model	NPN output	GT2-75N	GT2-76N	GT2-100N	GT2-E3N
	PNP output	GT2-75P	GT2-76P	GT2-100P	GT2-E3P
Mounting method	Panel mount			Panel mount/Screw mounting using optional mounting bracket	Installed into GT2-100N/100P (up to 3 boards)
Main unit / Expansion unit *1	Main unit	Expansion unit		2 channels provided as standard. Addition of expansion boards allows expansion to 11 channels max.	Expansion unit (1 to 3 channels)
Appearance					
Power supply voltage *1	10 to 30 VDC, including 10% ripple (P-P)			20 to 30 VDC, including 10% ripple (P-P)	Supplied from GT2-100N/100P
Power consumption *2	Normal	2200 mW max. (30 V, 73.3 mA max.)		4500 mW max. (30 V, 150 mA max.)	4200 mW max. (30 V, 140 mA max.)
	Power saving (Eco)	1700 mW max. (30 V, 56.7 mA max.)		3600 mW max. (30 V, 120 mA max.)	4000 mW max. (30 V, 133.3 mA max.)
Display power	Measured value display	6 + 1/2-digit 7-segment LED (red)			
	Other displays	2-colour, 13-level bar LED display (red, green), indicators (red, green)			
Display range	-199.999.9 to 199.999.9				
Display resolution	0.1 μm				
Sampling rate	1000 times/sec.				
Control input	Timing input	Input time: 2 ms min.			
	Preset input				
	Reset input				
	Bank input	Input time: 20 ms min.			
Control output	HH / High / Go / low / LL	NPN/PNP open collector, non-voltage output. Applicable current: 50 mA, Maximum applicable voltage (NPN: 40 V, PNP: 30 V) Residual voltage at ON: 1 V max. * N.O./N.C switchable (Applicable current decreases to 20 mA or lower when 2 or more sensor heads are connected to the GT2-100 Series.)			
Response time	hsp (3 ms), 5 ms, 10 ms, 100 ms, 500 ms, 1 s				
Environmental resistance	Ambient temperature	-10 to +50°C			
	Relative humidity	35 to 85% RH (No condensation)			
	Vibration	10 to 55 Hz, 1.5 mm double amplitude, 2 hours in each of X, Y, and Z directions (GT2-100N/P: 0.15 mm double amplitude)			
Materials	Main body case: Polycarbonate, Key top: Polyacetal, Front sheet: PET, Cable: PVC (GT2-75N/75P/76N/76P only)				-
Power supply / I/O cable	12-core connector connection (Connecting cable included)			Power supply: Terminal block, I/O: 20-pin connector (MIL standard)	I/O: 30-pin connector (MIL standard)
Weight	GT2-75N/75P/76N/76P: Approx. 140 g (including panel mounting bracket, protective front cover and power cable)				
	GT2-100N/100P: Approx. 380 g, GT2-E3N/E3P: Approx. 80 g				
Accessories	GT2-75N/75P: Panel mounting bracket, protective front cover, power cable, instruction manual, cover seal				
	GT2-76N/76P: Panel mounting bracket, protective front cover, power cable, expansion cable GT2-100N/100P: Instruction manual, panel mounting bracket, GT2-E3N/E3P: None				

\*1 Precautions when the GT2-70 Series is used with an expansion unit (excluding GT2-71D)

Up to 15 amplifier units can be connected; main unit: 1 unit, expansion unit: 14 units. To use the DIN-rail mount type, be sure to mount the amplifier unit to a DIN-rail (using the metal bracket). When mounting additional units, be sure to use the end units (OP-26751). When mounting additional units, depending on the number of units to be added, confirm the following specification limitations.

<Up to 8 units (including main unit)>

- The power supply voltage is 20 to 30 VDC.
- The maximum applicable current for each output is 20 mA.

<Up to 9 to 15 units (including main unit)>

- The power supply voltage is 20 to 30 VDC.
- The maximum applicable current for each output is 10 mA (including DL-RB1A output current).
- The residual voltage at ON is 1.5 V or less.

\*2 For GT2-100 Series, when the maximum number of sensor heads are connected and all units are set to power saving mode

I DIN-rail mount type pulse output amplifier unit

<b>Model</b>		<b>GT2-71D</b>	
<b>Appearance</b>			
<b>Mounting method</b>		DIN-rail mount	
<b>Power supply voltage</b>		10 to 30 VDC, including 10% ripple (P-P)	
<b>Current consumption</b>		1600 mW (30 V, 53.3 mA max.)	
<b>Indicator</b>		Power supply (green)/Alarm (red) indicator, pulse output indicator (green), input indicator (green)	
<b>Pulse resolution</b>		Selectable from 0.1 μm, 0.5 μm, 1 μm, and 10 μm (Factory setting: 0.5 μm)	
<b>Minimum phase difference</b>		Selectable from 0.5 μs, 2.5 μs, 5 μs, and 25 μs (Factory setting: 2.5 μs)	
<b>Control input</b>	<b>Origin return</b>	Input time: 20 ms min.	
<b>Output signal</b>		90° phase difference, differential square wave (EIA-422 compliant)	
<b>Output signal level</b>		+5V, øA, øA-, øB, øB-, øZ, øZ-: Line driver output	
<b>Environmental resistance</b>	<b>Ambient temperature</b>	-10 to +50°C	
	<b>Relative humidity</b>	35 to 85% RH (No condensation)	
	<b>Vibration</b>	10 to 55 Hz, 1.5 mm double amplitude, 2 hours in each of X, Y, and Z directions	
<b>Material</b>		Main body case: Polycarbonate, Cable: PVC	
<b>Weight</b>		Approx. 110 g (including power supply cable)	
<b>Accessories</b>		Instruction manual, SW protection sticker	

EtherNet/IP supported Communication Unit DL-EP1



<b>Model</b>		<b>DL-EP1</b>	
<b>Appearance</b>			
<b>EtherNet/IP</b>	<b>Supported functions</b>	Cyclic Communication Message Communication (Explicit Message Communication) UCMM and Class 3 supported	
	<b>Connection rate</b>	64	
	<b>RPI (Communication Frequency)</b>	0.5 to 10000 ms (unit of 0.5 ms)	
	<b>Cyclic Communication allowable communication bandwidth</b>	6000pps	
	<b>Conformance Test</b>	Supports version A7	

DeviceNet supported Communication Unit DL-DN1

<b>Model</b>		<b>DL-DN1</b>		
<b>Appearance</b>				
<b>DeviceNet Specifications</b>	<b>Supported functions</b>	Supported Function Input/output communication (poll)/ Explicit Message Communication		
	<b>Address Settings</b>	0 to 63 (PGM supported)		
	<b>Communication speed (Automatic switching method)</b>	500 kbps	250 kbps	125 kbps
	<b>Maximum cable length</b>	100 m (thick cable) 100 m (thin cable)	250 m (thick cable) 100 m (thin cable)	500 m (thick cable) 100 m (thin cable)
	<b>Network power source</b>	DC11-25V (DeviceNet provided from the communication power source)		

RS-232C Communication Unit DL-RS1A

<b>Model</b>		<b>DL-RS1A</b>	
<b>Appearance</b>			
<b>RS-232C Specifications</b>	<b>Communication Method</b>	Full duplex	
	<b>Synchronization Method</b>	Start-stop	
	<b>Transmission Code</b>	ASCII	
	<b>Baud rate</b>	2400/4800/9600/19200/38400 bps	

BCD Output Unit DL-RB1A

<b>Model</b>		<b>DL-RB1A</b>	
<b>Appearance</b>			
<b>BCD Output Specifications</b>	<b>Input/Output Terminal</b>	34 pin connector (MIL Standard)	
	<b>Control Output</b>	BCD Output: 4 (1 column) x 6 columns, signal output, strobe output, alarm output NPN Open connector 40V, 20mA or less, residual voltage 1V or less Positive logic/Negative logic can be switched	
	<b>Control Input</b>	Control Input ID Selection Input: 4, data request input No voltage input (connection point/ no connection point) input time 2 ms or more, short circuit current 1 mA	

All models Common specifications

<b>Model</b>	<b>DL-EP1</b>	<b>DL-DN1</b>	<b>DL-RS1A</b>	<b>DL-RB1A</b>
<b>Power source voltage</b>	DC20 to 30V Ripple (P-P) including 10% (Supplied from the connected sensor amplifier)			
<b>Weight (Including the connector)</b>	Approx. 70g	Approx. 80g	Approx. 53g	Approx. 46g

I/O circuit (GT2-71N/72N/71CN/72CN/71MCN/75N/76N)

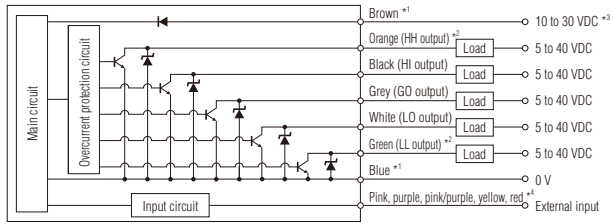

External input circuit

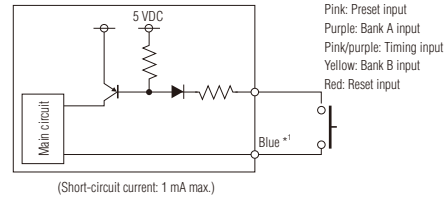

I/O circuit (GT2-71P/72P/71CP/72CP/71MCP/75P/76P)

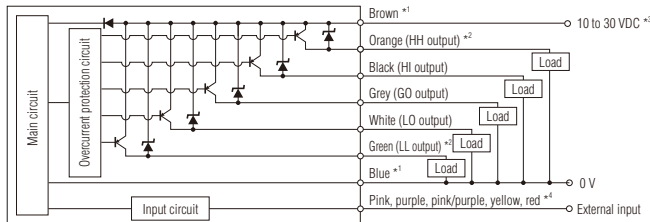

External input circuit

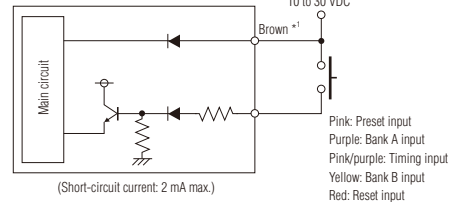

- \*1 Brown and blue are applicable only to main units (GT2-71N/71P/71CN/71CP/71MCN/71MCP/75N/75P). Not to expansion units (GT2-72N/72P/72CN/72CP/76N/76P). The connector type expansion unit (GT2-72CN/72CP) is not connected to the internal circuit.
- \*2 The orange and green cables are used as analogue output cables for the analogue type amplifier unit (GT2-71MCN/71MCP). For details, refer to the analogue output circuit diagram.
- \*3 20 to 30 VDC when expansion unit is connected or for the analogue type amplifier unit (GT2-71MCN/71MCP).
- \*4 For details on external input, refer to the external input circuit diagram.

Analogue output circuit  
GT2-71MCN/71MCP

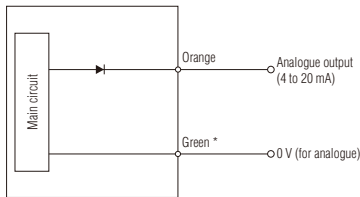

\* The green and blue cables are common internally.

Pulse output amplifier unit (GT2-71D)  
I/O circuit

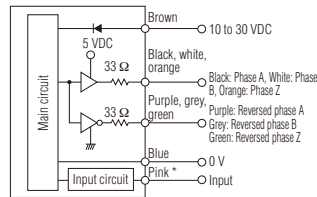

\* For details of the external input, refer to the diagram of the external input circuit.

External input circuit

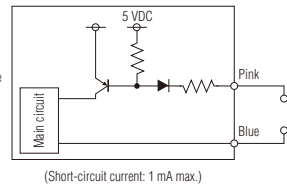

Recommended input device

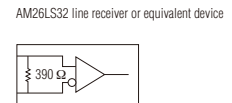

Output circuit of the large display amplifier unit  
GT2-100N/GT2-E3N  
(Pin Nos. 1 to 5, 11 to 15, 21 to 25)

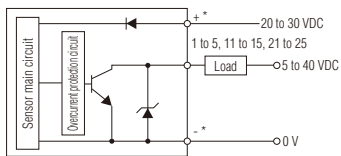

\* The +/- terminals are provided in the GT2-100N only. They are not provided in the GT2-E3N.

Input circuit of the large display amplifier unit  
GT2-100N/GT2-E3N  
(Pin Nos. 6 to 10, 16 to 20, 26 to 30)

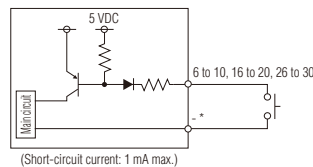

\* The - terminal is provided in the GT2-100N only. It is not provided in the GT2-E3N.

Output circuit of the large display amplifier unit  
GT2-100P/GT2-E3P  
(Pin Nos. 1 to 5, 11 to 15, 21 to 25)

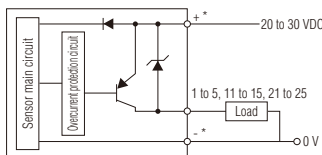

\* The +/- terminals are provided in the GT2-100P only. They are not provided in the GT2-E3P.

Input circuit of the large display amplifier unit  
GT2-100P/GT2-E3P  
(Pin Nos. 6 to 10, 16 to 20, 26 to 30)

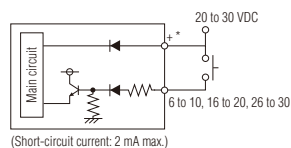

\* The + terminal is provided in the GT2-100P only. It is not provided in the GT2-E3P.

For details of the I/O connector pin assignment and the expansion board, refer to the instruction manual. The information is also available at the KEYENCE home page.

[www.keyence.com](http://www.keyence.com)

Unit: mm

**Sensor head (Standard)  
GT2-H12K/GT2-H12**

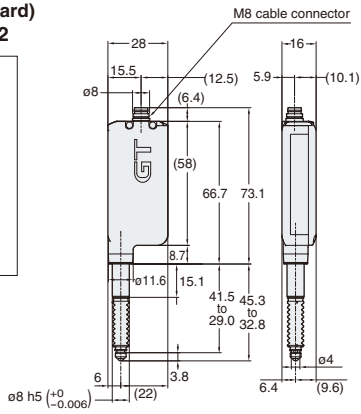

**Cable connection  
(Straight)**

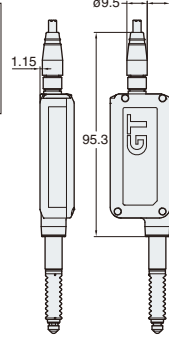

**Cable connection  
(L-shaped)**

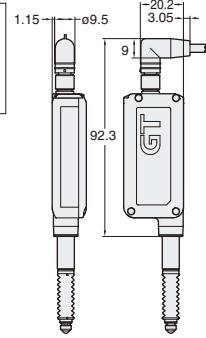

**Sensor head (Low stress)  
GT2-H12KL/GT2-H12L**

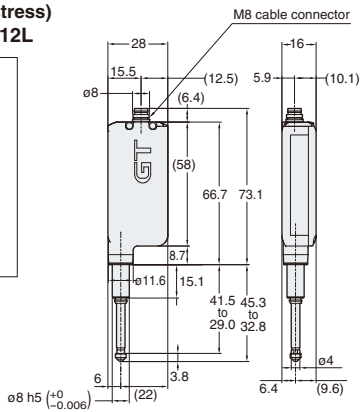

**Cable connection  
(Straight)**

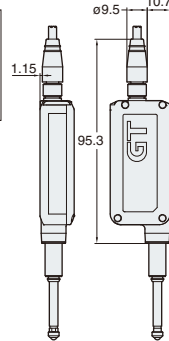

**Cable connection  
(L-shaped)**

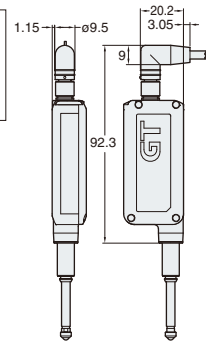

**Sensor head (Standard)  
GT2-H32**

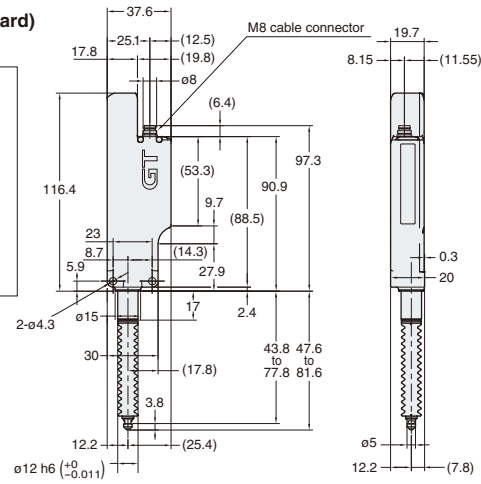

**Cable connection  
(Straight)**

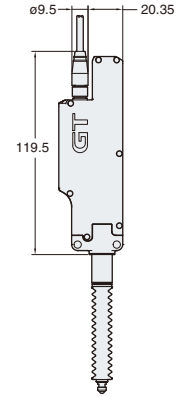

**Sensor head  
(Low stress)  
GT2-H32L**

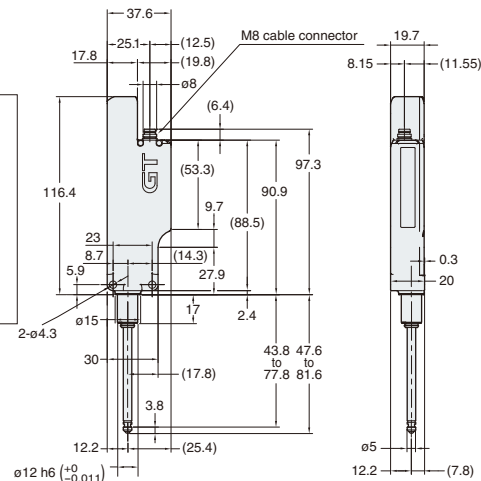

**Cable connection  
(Straight)**

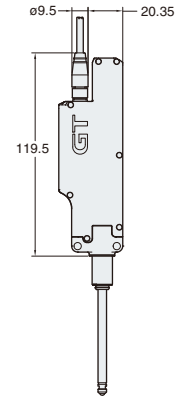



**Sensor head cable (Straight)**  
**GT2-CH2M/CH5M/CH10M/CH20M (Optional)**

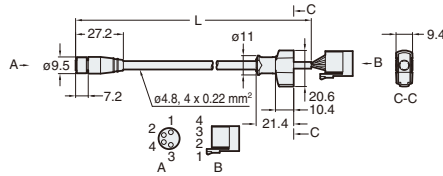

A	B	Sheath colour
1	1	Brown
2	3	White
3	4	Blue
4	2	Black

Model	L
GT2-CH2M	2000
GT2-CH5M	5000
GT2-CH10M	10000
GT2-CH20M	20000

**Sensor head cable (L-shaped)**  
**GT2-CHL2M/CHL5M/CHL10M/CHL20M (Optional)**

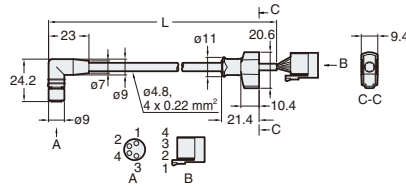

A	B	Sheath colour
1	1	Brown
2	3	White
3	4	Blue
4	2	Black

Model	L
GT2-CHL2M	2000
GT2-CHL5M	5000
GT2-CHL10M	10000
GT2-CHL20M	20000

**Sensor head mounting bracket A (Optional)**  
**OP-76874**

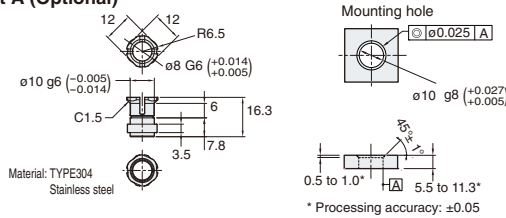

**Dust boot**



\* The dust boot is factory-attached to the sensor head (except for the low stress type).  
 Material: TYPE304 Stainless steel, NBR

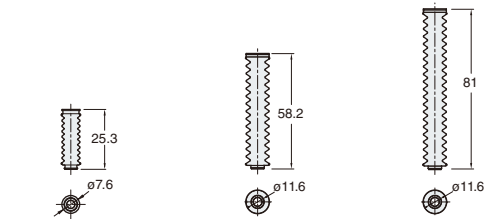

For GT2-H12K/H12/A12K/A12 (Optional)  
**OP-84332**

For GT2-H32/A32 (Optional)  
**OP-84459**

For GT2-H50/A50 (Optional)  
**OP-84460**

**Sensor head mounting bracket C (Optional)**  
**OP-84396**

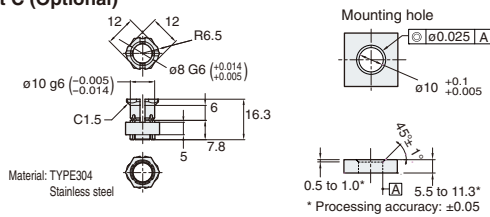

**Sensor head mounting bracket B (Optional)**  
**OP-76875**

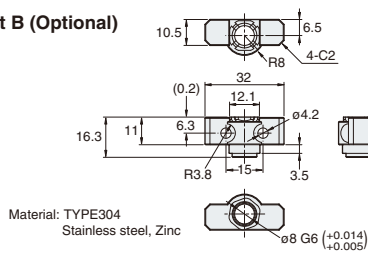

**Sensor head mounting bracket D (Optional)**  
**OP-84327**

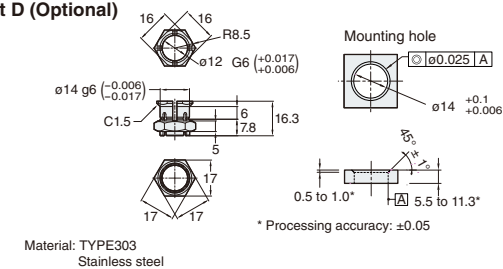

**Contact**

**Standard  
OP-77678**

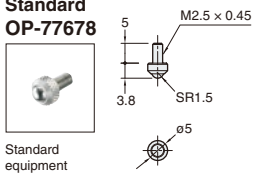

Standard equipment of the general-purpose sensor head  
**GT2-H12 (L)/H32 (L)/H50/A12 (L)/A32/A50**

Material: TYPE304  
Stainless steel  
TYPE40C  
Stainless steel

**Super-tough  
OP-77682**

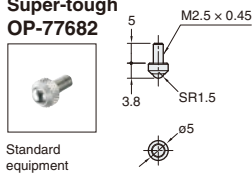

Standard equipment of the high-precision type sensor head  
**GT2-H12K (L)/A12K (L)**

Material: TYPE304  
Stainless steel  
Super-tough tungsten alloy

**Flat plate (Optional)  
OP-77679**

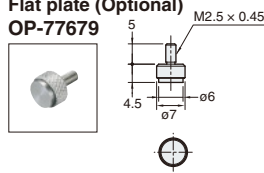

Material: TYPE304  
Stainless steel  
Super-tough tungsten alloy

**Roller (Optional)  
OP-77680**

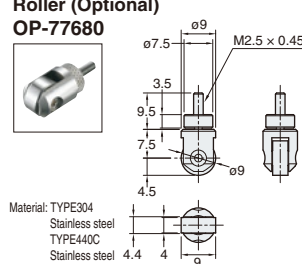

Material: TYPE304  
Stainless steel  
TYPE40C  
Stainless steel

**Fluorocarbon resin (Optional)  
OP-80228**

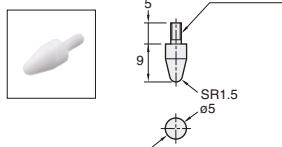

Material: Fluorocarbon resin (PTFE)

**Ceramic (Optional)  
OP-81970**

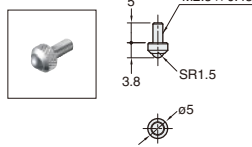

Material: TYPE304 Stainless steel,  
Ceramic

**Needle (Optional)  
OP-77681**

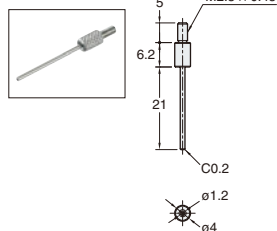

Material: TYPE304  
Stainless steel  
Super-tough tungsten alloy

**Offset (Optional)  
OP-77683**

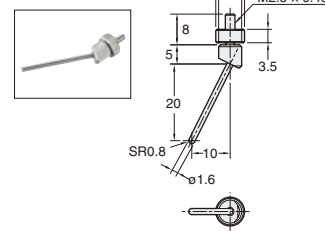

Material: TYPE304  
Stainless steel  
Super-tough tungsten alloy

**Lift lever (Optional)  
OP-84397**

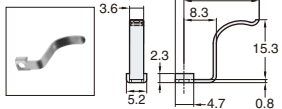

Material: TYPE304  
Stainless steel

**Spacer (Optional)  
OP-77684**

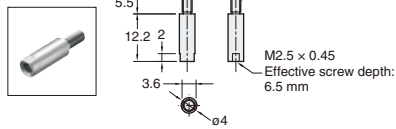

Material: TYPE304  
Stainless steel

**Amplifier unit  
DIN-rail mounting type**



**GT2-71N/71P/71MCN/71MCP/71CN/71CP**

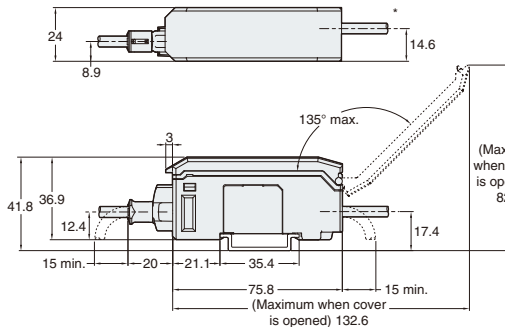

**GT2-72N/72P/72CN/72CP**

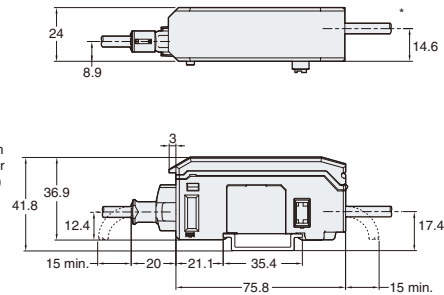

\* Cable specifications

GT2-71N/71P: ø4.7, 12-core x Brown/Blue: 0.20 mm<sup>2</sup>, Black/White/Grey/Orange/Green/Pink/Purple/Yellow/Red/Pink purple: 0.15 mm<sup>2</sup>, Cable length: 2 m  
GT2-72N/72P: ø4.7, 10-core x Black/White/Grey/Orange/Green/Pink/Purple/Yellow/Red/Pink purple: 0.15 mm<sup>2</sup>, Cable length: 2 m

**GT2-71MCN/71MCP/71CN/71CP/72CN/72CP**

**Connector  
(connector type/analogue output type amplifier unit)**

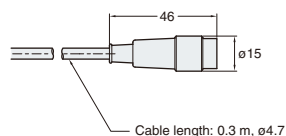

Cable length: 0.3 m, ø4.7

**GT2-CA2M/CA10M**

**Connection cable**

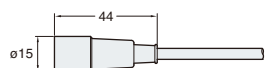

\* Cable specifications

Outer diameter: ø4.7 mm, Cable length: 2 m (GT2-CA2M), 10 m (GT2-CA10M), 12-core x Brown/Blue: 0.20 mm<sup>2</sup>, Black/White/Grey/Orange/Green/Pink/Purple/Yellow/Red/Pink purple: 0.15 mm<sup>2</sup>

**Amplifier unit  
Pulse output amplifier unit**



**GT2-71D**

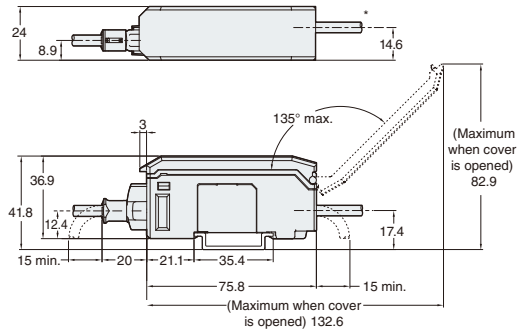

\* Cable specifications  
Outer diameter: ø4.7 mm, Cable length: 2 m,  
9-core x Brown/Blue/Purple/Pink/Orange/Green/Grey/White/Black: 0.15 mm<sup>2</sup>

**Mounting bracket for  
DIN-rail mounting type  
amplifier (Optional)  
OP-76877**

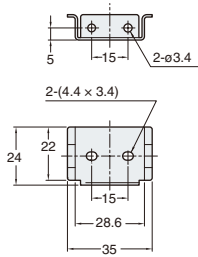

Material: SPCC steel

**End unit (Optional) (2 pcs.)  
OP-26751**

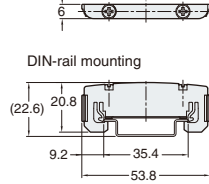

Material: Polycarbonate, Stainless steel

**When several units are connected**

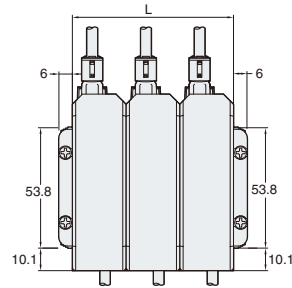

Number of units	L
1	24
2	48
3	72
4	96
5	120
6	144
7	168
8	192
9	216
10	240
11	264
12	288
13	312
14	336
15	360

**Amplifier unit  
Panel mounting type**



**GT2-75N/75P/76N/76P**

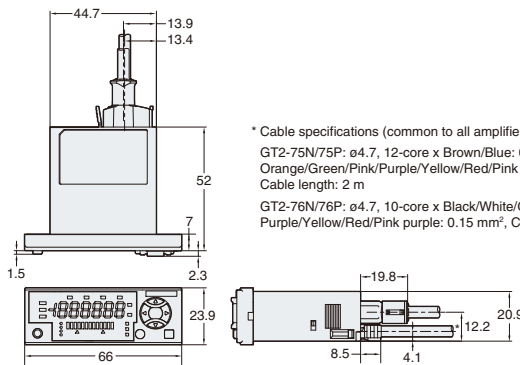

\* Cable specifications (common to all amplifier units)  
GT2-75N/75P: ø4.7, 12-core x Brown/Blue: 0.20 mm<sup>2</sup>, Black/White/Grey/Orange/Green/Pink/Purple/Yellow/Red/Pink purple: 0.15 mm<sup>2</sup>, Cable length: 2 m  
GT2-76N/76P: ø4.7, 10-core x Black/White/Grey/Orange/Green/Pink/Purple/Yellow/Red/Pink purple: 0.15 mm<sup>2</sup>, Cable length: 2 m

**Panel mounting bracket  
(Accessory)  
OP-84394**

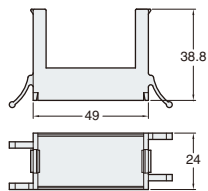

**Protective front cover**

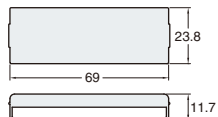

Material: (Mounting bracket) Polyacetal,  
(Protective front cover) Polycarbonate

**Panel cutout**

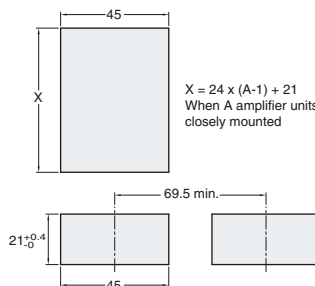

X = 24 x (A-1) + 21  
When A amplifier units are closely mounted

**Panel mounting bracket**

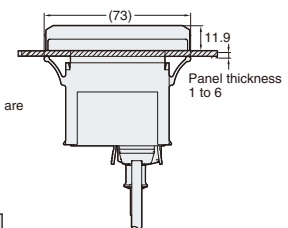

**Amplifier unit  
Large display  
GT2-100N/100P**



**When the supplied mounting bracket is attached**

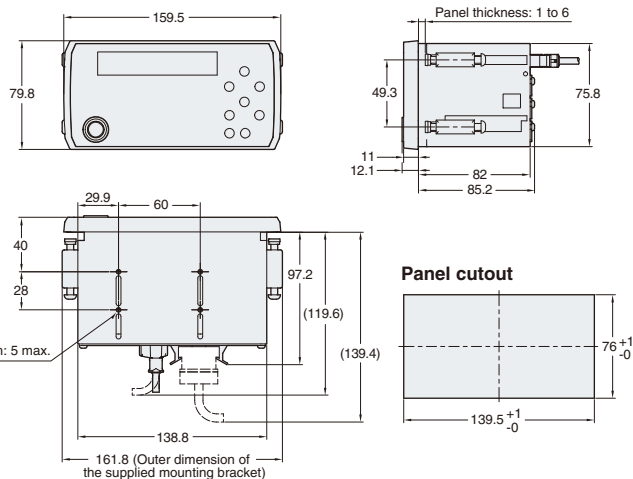

Screw hole for mounting OP-84331  
Nominal diameter: 3, Tapping depth: 5 max.

**GT2-E3N/E3P Expansion board**

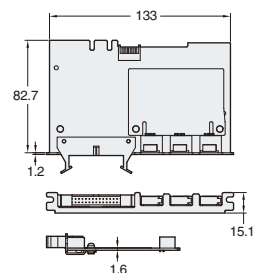

**When the optional mounting bracket (OP-84331) is used**

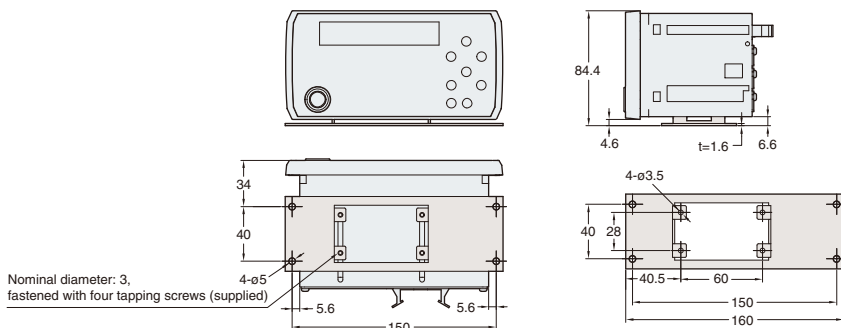

**Communication unit (EtherNet/IP Unit)  
DL-EP1**

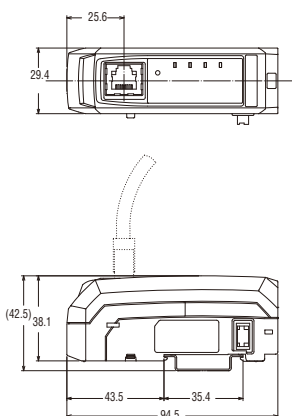

**Communication unit (DeviceNet Unit)  
DL-DN1**

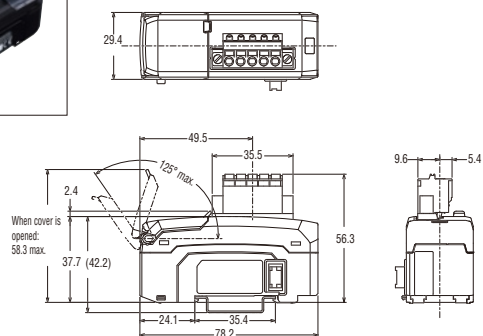

**Communication unit (BCD output type)  
DL-RB1A**



34-pin MIL connector

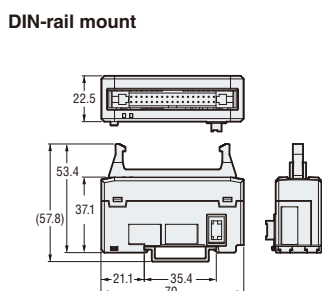

**Communication unit (RS-232C communication type)  
DL-RS1A**

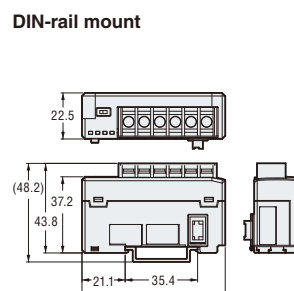

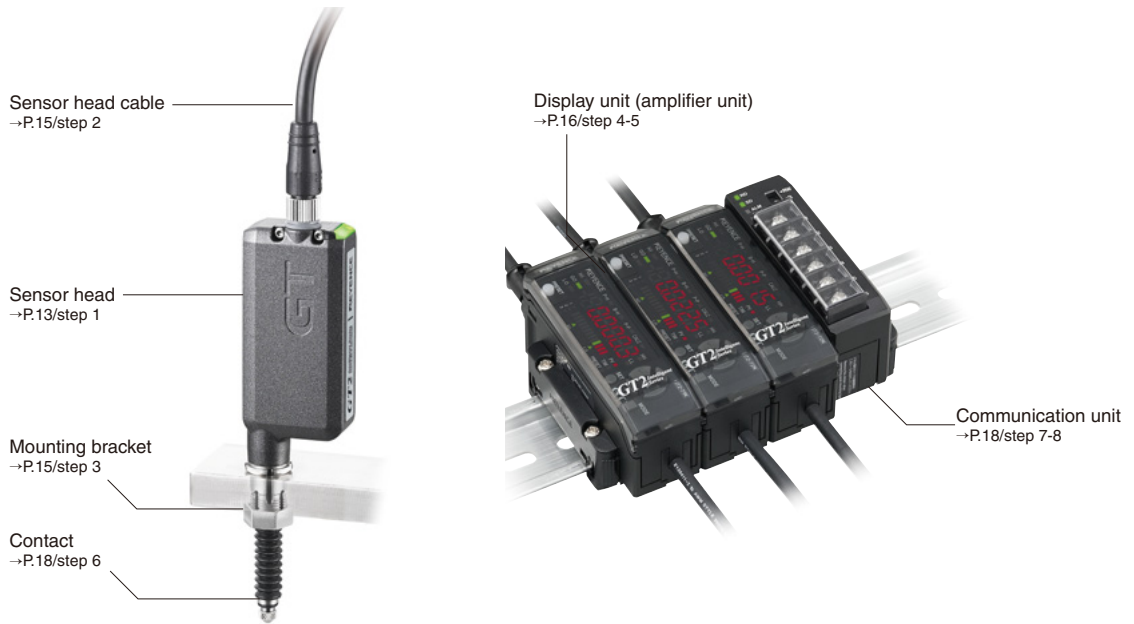

Reference

### Calculation functions using expansion units

The GT2-70 Series\* enables calculations such as the calculation of the maximum and the minimum values of several detection points when several expansion units (up to 14 units) are connected to a main unit. Outline of each calculation function is as follows:

No.	Calculation function	Description	Number of connectable expansion units	
			Calculation mode	Dedicated Calculation mode
C1	Maximum value display	The maximum value among measurement results of main unit and expansion units is defined as a judgment value.	1 to 14 units	2 to 14 units
C2	Minimum value display	The minimum value among measurement results of main unit and expansion units is defined as a judgment value.		
C3	Degree of flatness display	A difference between maximum and minimum values among measurement results of main unit and expansion units is defined as a judgment value.		
C4	Average display	The sum of measurement results of main unit and expansion units is divided by the number of connected units, and the average value is defined as a judgment value.		
C5	Reference difference display	Displayed value on the main unit is subtracted from that on the expansion unit, and the difference is defined as a judgment value.		
C6	Twist display	A twist level on four detecting points is defined as a judgment value.	Only 3 units	Only 4 units
C7	Warpage display	A warp level on three detecting points is defined as a judgment value.	Only 2 units	Only 3 units
C8	Thickness display	With a target sandwiched by main unit and expansion unit, the thickness is defined as a judgment value.	Only 1 unit	Only 2 units

\* Except GT2-71D.

### Bank function

With the bank function, up to four patterns of HH, HIGH, LOW and LL set values, preset points and preset values can be registered in advance. Since the registered settings (four patterns) can be easily changed, this function is useful for detection of several targets.

### About accuracy of the high-precision type

When the high-precision type measures a distance between two arbitrary points in the measuring range at an ordinary temperature (20°C), the deviation from the actual value is 1 μm or less. For example, when a measurement result is 11 mm, the actual value is in a range of 10.999 to 11.001 mm. For several measurements, variations in the measured value are 1 μm or less.

### About "Calculation mode"

When "Calculation mode" is selected for "A1: Calculation mode", the main unit outputs a calculation result, and output of the expansion unit is OFF. (Except for a case where "C5: Difference from reference display" is selected)

**NOTE** - The calculation mode can be selected for the main unit to which one or more expansion units are connected.

### About "Calculation dedicated mode"

When "Calculation dedicated mode" is selected for "A1: Calculation mode", only the main unit outputs a calculation result, and the expansion unit outputs a judgment result based on each setting.

**NOTE** - The calculation dedicated mode can be selected for the main unit to which two or more expansion units are connected.  
 - When the calculation dedicated mode is selected, "C5: Difference from reference display" cannot be selected for calculation method.  
 - When the calculation dedicated mode is selected, a sensor head cannot be connected to the main unit. Attach the supplied "sensor head connector seal" to the sensor head connector of the main unit.

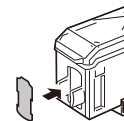

### 5-output function (Except GT2-71MCN/71MCP)

This function enables differentiation of five output statuses (HH, HIGH, GO, LOW and LL). HH and LL outputs can also be used for jam checking (limit out).

# General purpose digital contact sensor

GT Series



## FEATURES

### [Easy setup]

Head installation is as easy as drilling a hole.

### [Easy programming]

Auto-tuning function enables simple, sensor-like tuning.

### [Smart operation]

Self-diagnostic function outputs an alarm when the sensor head cable becomes damaged



## SETUP

### Amplifier units

Model	Appearance	Type	Output type
GT-71A		Main unit	NPN
GT-72A		Expansion unit	
GT-71AP		Main unit	PNP
GT-72AP		Expansion unit	
GT-75A		Main unit	NPN
GT-76A		Expansion unit	PNP
GT-75AP		Main unit	
GT-76AP		Expansion unit	

### BCD output / RS-232C communication unit

Model	Appearance	Type
DL-EP1		EtherNet/IP
DL-DN1		DeviceNet
DL-RB1A		BCD
DL-RS1A		RS-232C

### Standard model

**Shortest in its class**  
Total length 90 mm

Smallest length among the 10-mm stroke type sensor heads

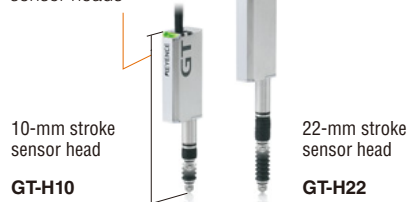

### Low Stress model

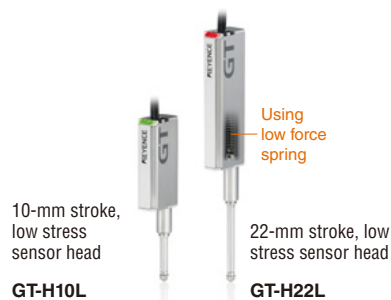

### Air Cylinder model

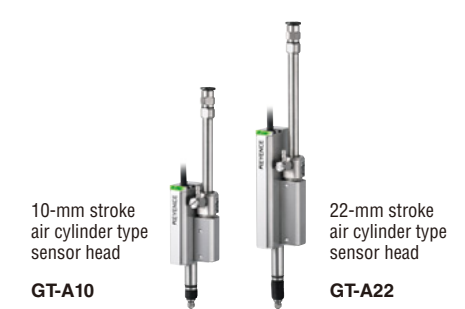



Please visit: [www.keyence.com](http://www.keyence.com)



**SAFETY INFORMATION**

Please read the instruction manual carefully in order to safely operate any KEYENCE product.

**KEYENCE CORPORATION**

1-3-14, Higashi-Nakajima, Higashi-Yodogawa-ku, Osaka, 533-8555, Japan Phone: +81-6-6379-2211

**AUSTRIA**  
Phone: +43 22 36-3782 66-0 Fax: +43 22 36-3782 66-30

**BELGIUM**  
Phone: +32 1 528 1222 Fax: +32 1 520 1623

**BRAZIL**  
Phone: +55-11-3045-4011 Fax: +55-11-3045-5219

**CANADA**  
Phone: +1-905-366-7655 Fax: +1-905-366-1122

**CHINA**  
Phone: +86-21-68757500 Fax: +86-21-68757550

**CZECH REPUBLIC**  
Phone: +420 222 191 483 Fax: +420 222 191 505

**FRANCE**  
Phone: +33 1 56 37 78 00 Fax: +33 1 56 37 78 01

**GERMANY**  
Phone: +49 61 02 36 89-0 Fax: +49 61 02 36 89-100

**HONG KONG**  
Phone: +852-3104-1010 Fax: +852-3104-1080

**HUNGARY**  
Phone: +36 1 802 73 60 Fax: +36 1 802 73 61

**INDIA**  
Phone: +91-44-4963-0900 Fax: +91-44-4963-0901

**INDONESIA**  
Phone: +62-21-2939-8766 Fax: +62-21-2939-8767

**ITALY**  
Phone: +39-02-6688220 Fax: +39-02-66825099

**JAPAN**  
Phone: +81-6-6379-2211 Fax: +81-6-6379-2131

**KOREA**  
Phone: +82-31-789-4300 Fax: +82-31-789-4301

**MALAYSIA**  
Phone: +60-3-2092-2211 Fax: +60-3-2092-2131

**MEXICO**  
Phone: +52-81-8220-7900 Fax: +52-81-8220-9097

**NETHERLANDS**  
Phone: +31 40 20 66 100 Fax: +31 40 20 66 112

**POLAND**  
Phone: +48 71 36861 60 Fax: +48 71 36861 62

**ROMANIA**  
Phone: +40 269-232-808 Fax: +40 269-232-808

**SINGAPORE**  
Phone: +65-6392-1011 Fax: +65-6392-5055

**SLOVAKIA**  
Phone: +421 2 5939 6461 Fax: +421 2 5939 6200

**SLOVENIA**  
Phone: +386 1-4701-666 Fax: +386 1-4701-699

**SWITZERLAND**  
Phone: +41 43-45577 30 Fax: +41 43-45577 40

**TAIWAN**  
Phone: +886-2-2718-8700 Fax: +886-2-2718-8711

**THAILAND**  
Phone: +66-2-369-2777 Fax: +66-2-369-2775

**UK & IRELAND**  
Phone: +44-1908-696900 Fax: +44-1908-696777

**USA**  
Phone: +1-201-930-0100 Fax: +1-201-930-0099

WW1-1093

