

Automation PC 2100

User's manual

Version: **2.01 (July 2024)**
Order no.: **MAAPC2100-ENG**

Translation of the original documentation

Publishing information

B&R Industrial Automation GmbH

B&R Strasse 1

5142 Eggelsberg

Austria

Telephone: +43 7748 6586-0

Fax: +43 7748 6586-26

office@br-automation.com

Disclaimer

All information in this document is current as of its creation. The contents of this document are subject to change without notice. B&R Industrial Automation GmbH assumes unlimited liability in particular for technical or editorial errors in this document only (i) in the event of gross negligence or (ii) for culpably inflicted personal injury. Beyond that, liability is excluded to the extent permitted by law. Liability in cases in which the law stipulates mandatory unlimited liability (such as product liability) remains unaffected. Liability for indirect damage, consequential damage, business interruption, loss of profit or loss of information and data is excluded, in particular for damage that is directly or indirectly attributable to the delivery, performance and use of this material.

B&R Industrial Automation GmbH notes that the software and hardware designations and brand names of the respective companies used in this document are subject to general trademark, brand or patent protection.

Hardware and software from third-party suppliers referenced in this document is subject exclusively to the respective terms of use of these third-party providers. B&R Industrial Automation GmbH assumes no liability in this regard. Any recommendations made by B&R Industrial Automation GmbH are not contractual content, but merely non-binding information for which no liability is assumed. When using hardware and software from third-party suppliers, the relevant user documentation of these third-party suppliers must additionally be consulted and, in particular, the safety guidelines and technical specifications contained therein must be observed. The compatibility of the products from B&R Industrial Automation GmbH described in this document with hardware and software from third-party suppliers is not contractual content unless this has been separately agreed in individual cases; in this respect, warranty for such compatibility is excluded in any case, and it is the sole responsibility of the customer to verify this compatibility in advance.

1 Introduction.....	9
1.1 Manual history.....	9
1.2 Information about this document.....	10
1.2.1 Organization of notices.....	10
1.2.2 Guidelines.....	10
2 General safety guidelines.....	11
2.1 Intended use.....	11
2.2 Protection against electrostatic discharge.....	11
2.2.1 Packaging.....	11
2.2.2 Regulations for proper ESD handling.....	11
2.3 Regulations and measures.....	12
2.4 Transport and storage.....	12
2.5 Installation.....	12
2.6 Operation.....	13
2.6.1 Protection against contact with electrical parts.....	13
2.6.2 Ambient conditions - Dust, moisture, aggressive gases.....	13
2.6.3 Programs, viruses and malicious programs.....	13
2.7 Cybersecurity disclaimer for products.....	14
3 System overview.....	15
3.1 About this user's manual.....	15
3.2 Maximum performance with compact dimensions.....	15
3.3 Communication in all directions.....	15
3.4 Best graphics performance.....	15
3.5 Features.....	15
3.6 Configuration.....	16
3.6.1 Order number key.....	17
3.7 Overview.....	18
4 Technical data.....	20
4.1 Complete system.....	20
4.1.1 Connection options.....	20
4.1.1.1 SDL operation.....	20
4.1.1.2 DVI operation.....	22
4.1.1.3 SDL3 operation.....	24
4.1.2 Mechanical properties.....	25
4.1.2.1 Dimensions.....	25
4.1.2.2 Drilling template.....	26
4.1.2.3 Spacing for air circulation.....	27
4.1.2.4 Mounting orientations.....	28
4.1.2.5 Weight specifications.....	28
4.1.3 Environmental properties.....	29
4.1.3.1 Temperature specifications.....	29
4.1.3.2 Relative humidity.....	33
4.1.3.3 Vibration.....	33
4.1.3.4 Shock.....	33
4.1.3.5 Degree of protection.....	33
4.1.4 Electrical properties.....	34
4.1.4.1 System units (5APC2100.BYxx-000) - Block diagram.....	34
4.1.4.2 Power calculation.....	35
4.1.5 Device interfaces and slots.....	36
4.1.5.1 Device interface overview.....	36
4.1.5.2 +24 VDC power supply.....	36
4.1.5.3 Ethernet interfaces.....	37
4.1.5.4 USB interfaces.....	38
4.1.5.5 CFast slot.....	39

4.1.5.6 Power and reset buttons.....	39
4.1.5.7 LED status indicators.....	40
4.1.5.8 Monitor/Panel interface.....	40
4.1.5.9 IF option slot(IF1, IFx).....	41
4.2 Individual components.....	42
4.2.1 System units.....	42
4.2.1.1 5APC2100.BYxx-000.....	42
4.2.2 Monitor/Panel options.....	46
4.2.2.1 5ACCLI01.SDL0-000.....	46
4.2.2.2 5ACCLI01.SDL3-000.....	49
4.2.3 Interface options.....	51
4.2.3.1 5ACCIF01.FPCC-000.....	51
4.2.3.2 5ACCIF01.FPCS-000.....	56
4.2.3.3 5ACCIF01.FPLK-000.....	60
4.2.3.4 5ACCIF01.FPLS-000.....	63
4.2.3.5 5ACCIF01.FPLS-001.....	66
4.2.3.6 5ACCIF01.FPSC-000.....	69
4.2.3.7 5ACCIF01.FPSC-001.....	73
4.2.3.8 5ACCIF01.FSS0-000.....	78
4.2.3.9 5ACCIF01.ICAN-000.....	82
4.2.3.10 5ACCIF01.IS00-000.....	85
4.2.4 CFast cards.....	86
4.2.5 Front covers.....	87
4.2.5.1 5ACCCFF00.000x-00x.....	87
5 Installation and wiring.....	89
5.1 Basic information.....	89
5.1.1 Installing an Automation PC.....	91
5.1.2 Changing the mounting type (removing/installing the mounting plate).....	92
5.1.3 Installing the USB hub.....	93
5.2 Connecting to the power grid.....	94
5.2.1 Installing the DC power cable.....	94
5.2.1.1 Wiring.....	94
5.2.2 Connecting the power supply to a B&R device.....	94
5.2.3 Grounding concept - Functional ground.....	95
5.3 Connecting cables.....	96
6 Commissioning.....	97
6.1 Basic information.....	97
6.2 Switching on the device for the first time.....	97
6.2.1 General information before switching on the device.....	97
6.2.2 Switching on the device.....	97
6.3 General instructions about the procedure for temperature testing.....	97
6.3.1 Procedure.....	98
6.3.2 Evaluating temperatures in Windows operating systems.....	98
6.3.2.1 Evaluating with the ADI Control Center.....	98
6.3.2.2 Evaluating with the BurnInTest tool from PassMark.....	98
6.3.3 Evaluating the measurement results.....	99
6.4 Known problems / Characteristics.....	100
7 Software.....	101
7.1 BIOS options.....	101
7.1.1 General information.....	101
7.1.2 BIOS Setup and start procedure.....	101
7.1.3 BIOS default settings.....	102
7.1.4 BIOS Setup buttons.....	102
7.1.5 Main.....	103

7.1.5.1 System information.....	103
7.1.6 Advanced.....	104
7.1.6.1 OEM features.....	105
7.1.6.2 CPU configuration.....	112
7.1.6.3 Graphics (IGD) configuration.....	114
7.1.6.4 LAN.....	116
7.1.6.5 PCI express configuration.....	117
7.1.6.6 USB configuration.....	119
7.1.6.7 SATA configuration.....	120
7.1.6.8 Miscellaneous configuration.....	120
7.1.6.9 Thermal configuration.....	121
7.1.7 Security.....	123
7.1.8 Boot.....	124
7.1.8.1 Boot device priority.....	124
7.1.8.2 Boot configuration.....	125
7.1.9 Exit.....	127
7.1.10 Allocation of resources.....	128
7.1.10.1 RAM address assignment.....	128
7.1.10.2 I/O address assignments.....	128
7.1.10.3 Interrupt assignments in PIC mode.....	128
7.1.10.4 Interrupt assignments in APIC mode.....	129
7.2 Upgrade information.....	130
7.2.1 BIOS upgrade.....	130
7.2.1.1 Basic information.....	130
7.2.1.2 Procedure in the EFI shell.....	131
7.2.2 Upgrading the firmware on the Automation PC 2100.....	132
7.2.2.1 Procedure in Windows (ADI Control Center).....	132
7.2.2.2 Procedure in the EFI shell.....	132
7.2.3 Automation Panel firmware upgrade.....	133
7.2.3.1 Procedure in Windows (ADI Control Center).....	133
7.2.3.2 Procedure in EFI shell.....	133
7.2.4 Firmware upgrade with Automation Runtime.....	133
7.3 Operating systems.....	134
7.3.1 Windows 10 IoT Enterprise 2016 LTSC.....	134
7.3.1.1 General information.....	134
7.3.1.2 Order data.....	134
7.3.1.3 Overview.....	134
7.3.1.4 Features.....	134
7.3.1.5 Installation.....	135
7.3.1.6 Drivers.....	135
7.3.1.7 Activation.....	135
7.3.1.8 Characteristics, limitations.....	136
7.3.1.9 Supported display resolutions.....	136
7.3.2 Windows 10 IoT Enterprise 2015 LTSC.....	137
7.3.2.1 General information.....	137
7.3.2.2 Order data.....	137
7.3.2.3 Overview.....	137
7.3.2.4 Features.....	137
7.3.2.5 Installation.....	138
7.3.2.6 Drivers.....	138
7.3.2.7 Activation.....	138
7.3.2.8 Content of delivery of the recovery DVD.....	139
7.3.2.9 Characteristics, limitations.....	139
7.3.2.10 Supported display resolutions.....	139
7.3.3 Windows Embedded 8.1 Industry Pro.....	140
7.3.3.1 General information.....	140
7.3.3.2 Order data.....	140

7.3.3.3 Overview.....	140
7.3.3.4 Features.....	140
7.3.3.5 Installation.....	141
7.3.3.6 Drivers.....	141
7.3.3.7 Activation.....	141
7.3.3.8 Content of delivery of the recovery DVD.....	142
7.3.3.9 Lockdown features.....	142
7.3.3.10 Supported display resolutions.....	142
7.3.4 Windows 7.....	143
7.3.4.1 General information.....	143
7.3.4.2 Order data.....	143
7.3.4.3 Overview.....	143
7.3.4.4 Installation.....	143
7.3.4.5 Drivers.....	144
7.3.4.6 Characteristics, limitations.....	144
7.3.4.7 Supported display resolutions.....	144
7.3.5 Windows Embedded Standard 7.....	145
7.3.5.1 General information.....	145
7.3.5.2 Order data.....	145
7.3.5.3 Overview.....	145
7.3.5.4 Features.....	145
7.3.5.5 Installation.....	146
7.3.5.6 Drivers.....	146
7.3.5.7 Characteristics, limitations.....	146
7.3.5.8 Supported display resolutions.....	146
7.3.6 Automation Runtime.....	147
7.3.6.1 General information.....	147
7.3.6.2 Order data.....	147
7.3.6.3 Automation Runtime Windows (ARwin).....	147
7.3.6.4 Automation Runtime Embedded (ARemb).....	148
7.3.6.5 Licensing.....	148
7.3.7 B&R Hypervisor.....	149
7.3.8 mapp Technology.....	150
7.3.9 Linux for B&R 8 (GNU/Linux).....	151
7.3.9.1 General information.....	151
7.3.9.2 Order data.....	151
7.3.9.3 Overview.....	151
7.3.9.4 Features.....	151
7.3.9.5 Installation.....	151
7.3.9.6 Drivers.....	152
7.3.10 Linux for B&R 9 (GNU/Linux).....	153
7.3.10.1 General information.....	153
7.3.10.2 Order data.....	153
7.3.10.3 Overview.....	153
7.3.10.4 Features.....	153
7.3.10.5 Installation.....	153
7.3.10.6 Drivers.....	154
7.4 Automation Device Interface (ADI).....	155
7.4.1 ADI Control Center.....	155
7.4.1.1 Functions.....	155
7.4.1.2 Installation.....	155
7.4.2 ADI Development Kit (Windows).....	156
7.4.3 ADI .NET SDK (Windows).....	157
7.5 Key Editor.....	158
7.6 KCF Editor.....	159
7.7 HMI Service Center.....	160
7.7.1 5SWUTI.0001-000.....	160

7.7.1.1 General information.....	160
7.7.1.2 Order data.....	160
8 Maintenance.....	161
8.1 Repairs/Complaints and replacement parts.....	161
8.2 Replacing CFast cards.....	161
9 International and national certifications.....	162
9.1 Directives and declarations.....	162
9.1.1 CE marking.....	162
9.1.2 EMC Directive.....	162
9.2 Certifications.....	163
9.2.1 UL certification.....	163
9.2.2 KC.....	163
9.2.3 UKCA.....	163
9.2.4 RCM.....	164
9.2.5 DNV certification.....	164
9.2.6 UL Haz. Loc. certification.....	165
9.2.6.1 General safety guidelines.....	165
9.2.6.2 Mounting and installation.....	165
9.2.6.3 Operation.....	165
9.2.6.4 Servicing, disturbances and removal.....	166
9.2.6.5 USB connection with the Automation PC 2100.....	167
9.2.6.6 USB connection with the 4-port hub.....	169
9.2.7 American Bureau of Shipping (ABS).....	170
9.2.8 Bureau Veritas (BV).....	170
9.2.9 Lloyd's Register (LR).....	170
9.2.10 Korean Register of Shipping (KR).....	171
10 Accessories.....	172
10.1 Cables.....	172
10.2 USB mass storage device.....	172
10.3 General information.....	172
10.3.1 Order data.....	172
10.4 Installation accessories.....	172
10.4.1 Order data.....	172
10.5 Terminal block power supply.....	173
10.5.1 0TB103.9x.....	173
10.5.1.1 General information.....	173
10.5.1.2 Order data.....	173
10.5.1.3 Technical data.....	173
10.6 Terminal block for IF options.....	174
10.6.1 0TB1210.3100.....	174
10.6.1.1 General information.....	174
10.6.1.2 Order data.....	174
10.6.1.3 Technical data.....	174
10.7 USB hub.....	175
10.7.1 5ACCUSB4.0000-000.....	175
10.7.1.1 General information.....	175
10.7.1.2 Order data.....	175
10.7.1.3 Technical data.....	175
10.7.1.4 Dimensions.....	177
11 Environmentally friendly disposal.....	178
11.1 Separation of materials.....	178
A.A Abbreviations.....	179
A.B Maintenance Controller Extended (MTCX).....	179

A.C Cable data.....	180
A.C.1 RS232 - Bus length and cable type.....	180
A.C.2 RS422 - Bus length and cable type.....	180
A.C.3 RS485 - Bus length and cable type.....	181
A.C.4 CAN - Bus length and cable type.....	181
A.D POWERLINK.....	182
A.D.1 LED "S/E" (status/error LED).....	182
A.D.1.1 Ethernet mode.....	182
A.D.1.2 POWERLINK V2 mode.....	182
A.D.1.3 System stop error codes.....	184
A.D.1.4 POWERLINK V2.....	184

1 Introduction

Information:

B&R makes every effort to keep documents as current as possible. The most current versions are available for download on the B&R website (www.br-automation.com).

1.1 Manual history

Version	Date	Change ¹⁾
2.01	July 2024	<ul style="list-style-type: none"> • Name change from "B&R Linux" to "Linux for B&R". • Updated the following sections: <ul style="list-style-type: none"> ◦ "International and national certifications" on page 162 ◦ "Known problems / Characteristics" on page 100 ◦ "BIOS options" on page 101 ◦ "Ethernet interfaces" on page 37 ◦ "USB interfaces" on page 38 ◦ "Operating systems" on page 134
2.00	October 2022	<ul style="list-style-type: none"> • Documented "5ACCIF01.IS00-000" on page 85. • Documented 5MMUSB.4096-02, see "USB mass storage device". • Documented front covers 5ACCRPC2.000x-000, see 172. • Added reference to the "Order number key" on page 17. • Documented section "Firmware upgrade with Automation Runtime" on page 133. • Updated the following sections: <ul style="list-style-type: none"> ◦ "DNV certification " on page 164 ◦ "International and national certifications" on page 162 ◦ "General safety guidelines" on page 11 ◦ "Software" on page 101 ◦ "USB hub" on page 175 and "Installing the USB hub" on page 93 ◦ CAN interface description, see "Interface options" on page 51 and "Appendix A" on page 179 • "CFast cards", "Cables" and "USB mass storage device" are described in their own documentation starting with this version.
1.25	2018-06-15	<ul style="list-style-type: none"> • Updated the following sections: <ul style="list-style-type: none"> ◦ "General safety guidelines" on page 11 ◦ "Configuration" on page 16 ◦ "Electrical properties" on page 34 ◦ "Grounding concept - Functional ground" on page 95 ◦ "Basic information" on page 89 ◦ "Known problems / Characteristics" on page 100 ◦ "Windows 10 IoT Enterprise 2016 LTSB" on page 134 ◦ "Windows 10 IoT Enterprise 2015 LTSB" on page 137 ◦ "Linux for B&R 8 (GNU/Linux)" on page 151 ◦ "UL certification" on page 163 ◦ "Maintenance" on page 161 ◦ "USB hub" on page 175 • Updated the following sections: <ul style="list-style-type: none"> ◦ "B&R Hypervisor" on page 149 ◦ "mapp Technology" on page 150 ◦ "Linux for B&R 9 (GNU/Linux)" on page 153
1.22	2017-12-06	<ul style="list-style-type: none"> • Documented interface option "5ACCIF01.FSS0-000" on page 78. • Documented CFast card 5CFAST.256G-10 CFast - see 5CFAST.xxxx-10. • Updated the following sections: <ul style="list-style-type: none"> ◦ "ADI Control Center" on page 155 ◦ "ADI Development Kit (Windows)" on page 156 ◦ "ADI .NET SDK (Windows)" on page 157 ◦ "Key Editor" on page 158 ◦ "KCF Editor" on page 159 ◦ "Windows 10 IoT Enterprise 2016 LTSB" on page 134 ◦ "Repairs/Complaints and replacement parts" on page 161 • Revised section "Installation and wiring" on page 89.

Version	Date	Change ¹⁾
		<ul style="list-style-type: none"> • Updated the following sections: <ul style="list-style-type: none"> ◦ "DNV certification " on page 164 ◦ "UL Haz. Loc. certification " on page 165 ◦ 5CASDL.0xxx-03 ◦ 5CASDL.0xx0-13
1.21	2016-11-07	<ul style="list-style-type: none"> • Documented system unit 5APC2100.BY48-000 on page 42. • Documented interface option "5ACCIF01.FPCS-000" on page 56. • Documented new revisions of the CFast cards - see 5CFAST.xxxx-10.

1) Editorial changes are not listed.

1.2 Information about this document

This document is not intended for end customers! The safety guidelines required for end customers must be incorporated into the operating instructions for end customers in the respective national language by the machine manufacturer or system provider.

1.2.1 Organization of notices

Safety notices

Contain **only** information that warns of dangerous functions or situations.

Signal word	Description
Danger!	Failure to observe these safety guidelines and notices will result in death, severe injury or substantial damage to property.
Warning!	Failure to observe these safety guidelines and notices can result in death, severe injury or substantial damage to property.
Caution!	Failure to observe these safety guidelines and notices can result in minor injury or damage to property.
Notice!	Failure to observe these safety guidelines and notices can result in damage to property.

General notices

Contain **useful** information for users and instructions for avoiding malfunctions.

Signal word	Description
Information:	Useful information, application tips and instructions for avoiding malfunctions.

1.2.2 Guidelines

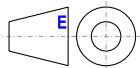

European dimension standards apply to all dimension diagrams.

All dimensions, specifications in dimension diagrams and associated tables are in millimeters [mm].

Unless otherwise specified, the following general tolerances apply:

Nominal dimension range	General tolerance per DIN ISO 2768 medium
Up to 6 mm	±0.1 mm
Over 6 to 30 mm	±0.2 mm
Over 30 to 120 mm	±0.3 mm
Over 120 to 400 mm	±0.5 mm
Over 400 to 1000 mm	±0.8 mm

2 General safety guidelines

2.1 Intended use

In all cases, applicable national and international standards, regulations and safety measures must be taken into account and observed!

The B&R products described in this manual are intended for use in industry and industrial applications. The intended use includes control, operation, monitoring, drive and HMI tasks as part of automation processes in machines and systems.

B&R products are only permitted to be used in their original condition. Modifications and extensions are only permitted if they are described in this manual.

B&R excludes liability for damage of any kind resulting from the use of B&R products in any intended way.

B&R products have not been designed, developed and manufactured for use that involves fatal risks or hazards that could result in death, injury, serious physical harm or other loss without the assurance of exceptionally stringent safety precautions.

B&R products are explicitly not intended for use in the following applications:

- Monitoring and control of thermonuclear processes
- Weapon systems control
- Flight and traffic control systems for passenger and freight transport
- Health monitoring and life support systems

2.2 Protection against electrostatic discharge

Electrical assemblies that can be damaged by electrostatic discharge (ESD) must be handled accordingly.

2.2.1 Packaging

- **Electrical assemblies with housing:**
Do not require special ESD packaging but must be handled properly (see "Electrical assemblies with housing").
- **Electrical assemblies without housing:**
Are protected by ESD-suitable packaging.

2.2.2 Regulations for proper ESD handling

Electrical assemblies with housing

- Do not touch the connector contacts of connected cables.
- Do not touch the contact tips on circuit boards.

Electrical assemblies without housing

The following applies in addition to "Electrical assemblies with housing":

- All persons handling electrical assemblies and devices in which electrical assemblies are installed must be grounded.
- Assemblies are only permitted to be touched on the narrow sides or front plate.
- Always place assemblies on suitable surfaces (ESD packaging, conductive foam, etc.). Metallic surfaces are not suitable surfaces!
- Assemblies must not be subjected to electrostatic discharges (e.g. due to charged plastics).
- A minimum distance of 10 cm from monitors or television sets must be maintained.
- Measuring instruments and devices must be grounded.
- Test probes of floating potential measuring instruments must be discharged briefly on suitable grounded surfaces before measurement.

Individual components

- ESD protective measures for individual components are implemented throughout B&R (conductive floors, shoes, wrist straps, etc.).
- The increased ESD protective measures for individual components are not required for handling B&R products at customer locations.

2.3 Regulations and measures

Electronic devices are generally not failsafe. If the programmable logic controller, operating or control device or uninterruptible power supply fails, the user is responsible for ensuring that connected devices (such as motors) are brought to a safe state.

When using programmable logic controllers as well as when using operating and monitoring devices as control systems in conjunction with a Soft PLC (e.g. B&R Automation Runtime or similar product) or Slot PLC (e.g. B&R LS251 or similar product), the safety measures that apply to industrial controllers (protection by protective equipment such as emergency stops) must be observed in accordance with applicable national and international regulations. This also applies to all other connected devices, such as drives.

All work such as installation, commissioning and servicing are only permitted to be carried out by qualified personnel. Qualified personnel are persons who are familiar with the transport, installation, assembly, commissioning and operation of the product and have the appropriate qualifications for their job (e.g. IEC 60364). National accident prevention regulations must be observed.

The safety guidelines, information about connection conditions (nameplate and documentation) and limit values specified in the technical data must be read carefully before installation and commissioning and must be strictly observed.

2.4 Transport and storage

During transport and storage, devices must be protected against undue stress (mechanical stress, temperature, humidity, aggressive atmosphere).

2.5 Installation

- The devices are not ready for use and must be installed and wired according to the requirements of this documentation in order to comply with EMC limit values.
- Installation must be carried out according to the documentation using suitable equipment and tools.
- Devices are only permitted to be installed in a voltage-free state and by qualified personnel. The control cabinet must first be disconnected from the power supply and secured against being switched on again.
- General safety regulations and national accident prevention regulations must be observed.
- The electrical installation must be carried out in accordance with relevant regulations (e.g. line cross section, fuse protection, protective ground connection).

2.6 Operation

2.6.1 Protection against contact with electrical parts

In order to operate programmable logic controllers, operating and monitoring devices and uninterruptible power supplies, it is necessary for certain components to carry dangerous voltages over 42 VDC. Touching one of these components can result in a life-threatening electric shock. There is a risk of death, serious injury or damage to property.

Before switching on programmable logic controllers, operating and monitoring devices and uninterruptible power supplies, it must be ensured that the housing is properly connected to ground potential (PE rail). Ground connections must also be made if the operating and monitoring device and uninterruptible power supply are only connected for testing purposes or only operated for a short time!

Before switching on, live parts must be securely covered. All covers must be kept closed during operation.

2.6.2 Ambient conditions - Dust, moisture, aggressive gases

The use of operating and monitoring devices (e.g. industrial PCs, Power Panels, Mobile Panels) and uninterruptible power supplies in dusty environments must be avoided. This can otherwise result in dust deposits that affect the functionality of the device, especially in systems with active cooling (fans), which may no longer ensure sufficient cooling.

The presence of aggressive gases in the environment can also result in malfunctions. In combination with high temperature and relative humidity, aggressive gases – for example with sulfur, nitrogen and chlorine components – trigger chemical processes that can very quickly impair or damage electronic components. Blackened copper surfaces and cable ends in existing installations are indicators of aggressive gases.

When operated in rooms with dust and condensation that can endanger functionality, operating and monitoring devices such as Automation Panels or Power Panels are protected on the front against the ingress of dust and moisture when installed correctly (e.g. cutout installation). The back of all devices must be protected against the ingress of dust and moisture, however, or the dust deposits must be removed at suitable intervals.

2.6.3 Programs, viruses and malicious programs

Any data exchange or installation of software using data storage media (e.g. floppy disk, CD-ROM, USB flash drive) or via networks or the Internet poses a potential threat to the system. It is the direct responsibility of the user to avert these dangers and to take appropriate measures such as virus protection programs and firewalls to protect against them and to use only software from trustworthy sources.

2.7 Cybersecurity disclaimer for products

B&R products communicate via a network interface and were developed for secure connection with internal and, if necessary, other networks such as the Internet.

Information:

In the following, B&R products are referred to as "product" and all types of networks (e.g. internal networks and the Internet) are referred to as "network".

It is the sole responsibility of the customer to establish and continuously ensure a secure connection between the product and the network. In addition, appropriate security measures must be implemented and maintained to protect the product and entire network from any security breaches, unauthorized access, interference, digital intrusion, data leakage and/or theft of data or information.

B&R Industrial Automation GmbH and its subsidiaries are not liable for damages and/or losses in connection with security breaches, unauthorized access, interference, digital intrusion, data leakage and/or theft of data or information.

The aforementioned appropriate security measures include, for example:

- Segmentation of the network (e.g. separation of the IT network from the control network¹⁾)
- Use of firewalls
- Use of authentication mechanisms
- Encryption of data
- Use of anti-malware software

Before B&R releases products or updates, they are subjected to appropriate functional testing. Independently of this, we recommend that our customers develop their own test processes in order to be able to check the effects of changes in advance. Such changes include, for example:

- Installation of product updates
- Significant system modifications such as configuration changes
- Deployment of updates or patches for third-party software (non-B&R software)
- Hardware replacement

These tests should ensure that implemented security measures remain effective and that systems in the customer's environment behave as expected.

¹⁾ The term "control network" refers to computer networks used to connect control systems. The control network can be divided into zones, and there can be several separate control networks within a company or site. The term "control systems" refers to all types of B&R products such as controllers (e.g. X20), HMI systems (e.g. Power Panel T30), process control systems (e.g. APROL) and supporting systems such as engineering workstations with Automation Studio.

3 System overview

3.1 About this user's manual

This user's manual contains all relevant information about an operational Automation PC 2100 cabinet-mounted device.

Information:

All specifications in dimension diagrams and associated tables are in millimeters [mm].

3.2 Maximum performance with compact dimensions

The control cabinet variant of the Automation PC 2100 offers a fully-fledged PC system with a minimum size. The PC design is based on Intel's Bay Trail architecture, which enables a broad spectrum in the embedded systems sector with single-, dual- and quad-core processors – and with an optimal price/performance ratio.



3.3 Communication in all directions

All important interfaces are integrated in the Automation PC 2100. This includes 2x Gigabit Ethernet, 1x USB 3.0 and USB 2.0 in each case. In addition, fieldbuses such as POWERLINK and CAN can be implemented via interface modules. The compact CFast card is used as the data storage medium, which is also available with 60 GB or more and based on MLC technology.

3.4 Best graphics performance

The graphics engine of the Intel Atom processors is derived from the Core i processors and offers powerful graphics processing. It supports DirectX 11 for the first time in this segment, which is now used in many SCADA systems with sophisticated graphics. On the display side, all resolutions and diagonals up to 24.0" Full HD are supported.









3.5 Features

- Intel Atom E3800 processors (Bay Trail)
- Up to quad-core CPU performance
- Powerful graphics (Intel HD graphics)
- Compact dimensions
- 2x Gigabit Ethernet
- SDL/DVI or SDL3
- 1x USB 3.0, 1x USB 2.0
- 1x CFast slot
- 1x slot for interface options
- Fanless operation

3.6 Configuration

The following individual components are required for an operational Automation PC 2100:

- System unit
- CFast card for the operating system
- Operating system

APC2100 configuration			
System units			Select 1.
	System unit	Processor	Processor - Clock frequency
	5APC2100.BY01-000	Intel Atom E3815	1460 MHz
	5APC2100.BY11-000	Intel Atom E3825	1330 MHz
	5APC2100.BY22-000	Intel Atom E3826	1460 MHz
	5APC2100.BY34-000	Intel Atom E3827	1750 MHz
	5APC2100.BY44-000	Intel Atom E3845	1910 MHz
	5APC2100.BY48-000	Intel Atom E3845	1910 MHz
Covers			Select 1.
	Front cover (without USB hub)¹⁾		Front cover (with USB hub)²⁾
	5ACCF00.0000-000		5ACCF00.0001-000
	5ACCF00.0000-001		5ACCF00.0001-001
5ACCF00.0000-002			5ACCF00.0001-002
CFast cards			Select 1.
	5CFAST.2048-00		5CFAST.032G-10
	5CFAST.4096-00		5CFAST.064G-10
	5CFAST.8192-00		5CFAST.128G-10
	5CFAST.016G-00		5CFAST.256G-10
	5CFAST.032G-00		
Interfaces			
	Graphics option		Optional, select 1.
	5ACCLI01.SDL0-000		
	5ACCLI01.SDL3-000		
	Interface options		
	5ACCIF01.FPCC-000	5ACCIF01.FPLK-000	5ACCIF01.FPCC-000
	5ACCIF01.FPLS-000	5ACCIF01.FPLS-001	5ACCIF01.FPSC-000
	5ACCIF01.FPSC-001	5ACCIF01.FSS0-000	5ACCIF01.ICAN-000
		5ACCIF01.IS00-000	
USB hub			Optional, select 1.
	5ACCUSB4.0000-000		
Accessories			Optional selection
	5MMUSB.2048-01	5MMUSB.4096-01	5MMUSB.032G-02
		5MMUSB.4096-02	
Terminal blocks			Select 1.
	Power supply connectors		
	0TB103.9		
	0TB103.91		
Operating systems			Select 1.
	Windows Embedded Standard 7		Windows 7
	5SWWI7.1542-ENG		5SWWI7.1100-ENG
	5SWWI7.1642-GER		5SWWI7.1100-GER
	5SWWI7.1742-MUL		5SWWI7.1300-MUL
	5SWWI7.1842-MUL		5SWWI7.1200-ENG
			5SWWI7.1200-GER
			5SWWI7.1400-MUL
	Windows Embedded 8.1 Industry		Automation Runtime
	5SWWI8.0342-MUL		0TG1000.01
	5SWWI8.0442-MUL		0TG1000.02
		1TG4600.10-5	
		1TG4601.06-5	
		Linux for B&R 8	
		5SWLIN.0542-MUL	
		5SWLIN.0642-MUL	
		Linux for B&R 9	
		5SWLIN.0742-MUL	

- 1) If no front cover is selected for the device configuration without a USB hub, front cover 5ACCF00.0000-000 (orange with the B&R logo) is installed and supplied as standard.
- 2) If no front cover is selected for the device configuration with a USB hub, front cover 5ACCF00.00001-000 (orange with the B&R logo) is installed and supplied as standard.

3.6.1 Order number key

Information:

A current order number key is available on the B&R website for easy identification of the device configuration:

[Home > Downloads > Industrial PCs and panels > Automation PC 2100](#)

3.7 Overview

Order number	Short description	Page
	Accessories	
0TB103.9	Connector 24 VDC - 3-pin, female - Screw clamp terminal block 3.31 mm ²	173
0TB103.91	Connector 24 VDC - 3-pin, female - Cage clamp terminal block 3.31 mm ²	173
5ACCSB4.0000-000	USB hub 4x passive - For APC2100/PPC2100	175
5SWUT1.0001-000	HMI Service Center USB flash drive - Hardware diagnostic software - For APC910/PPC900 - For PPC1200 - For APC2100/PPC2100 - For APC2200/PPC2200 - For APC3100/PPC3100 - For APC mobile - For AP800/AP900 - For AP9x3/AP9xD - For AP1000/AP5000	160
	Front covers	
5ACCF00.0000-000	APC2100 front cover - Orange - With B&R logo	87
5ACCF00.0000-001	APC2100 front cover - Dark gray - Without logo	87
5ACCF00.0000-002	APC2100 front cover - Orange - Without logo	87
5ACCF00.0001-000	APC2100 front cover - Orange - With B&R logo - For USB hub	87
5ACCF00.0001-001	APC2100 front cover - Dark gray - Without logo - For USB hub	87
5ACCF00.0001-002	APC2100 front cover - Orange - Without logo - For USB hub	87
	Interface options	
5ACCIF01.FPCC-000	Interface card - 2x CAN interfaces - 1x X2X Link interface - 1x POWERLINK interface - 512 kB nvSRAM - For APC2100/PPC2100/APC2200/PPC2200 - Only available with a new device	51
5ACCIF01.FPCS-000	Interface card - 1x RS485 interface - 1x CAN interface - 1x POWERLINK interface - 32 kB FRAM - For APC2100/PPC2100/APC2200/PPC2200 - Only available with a new device	56
5ACCIF01.FPLK-000	Interface card - 1x POWERLINK interface - Integrated 2-port hub - 512 kB nvSRAM - For APC2100/PPC2100/APC2200/PPC2200 - Only available with a new device	60
5ACCIF01.FPLS-000	Interface card - 1x RS232 interface - 1x POWERLINK interface - 32 kB FRAM - For APC2100/PPC2100/APC2200/PPC2200 - Only available with a new device	63
5ACCIF01.FPLS-001	Interface card - 1x RS232 interface - 1x POWERLINK interface - 512 kB nvSRAM - For APC2100/PPC2100/APC2200/PPC2200 - Only available with a new device	66
5ACCIF01.FPSC-000	Interface card - 1x RS232 interface - 1x CAN interface - 1x POWERLINK interface - 32 kB FRAM - For APC2100/PPC2100/APC2200/PPC2200 - Only available with a new device	69
5ACCIF01.FPSC-001	Interface card - 1x RS232 interface - 1x CAN interface - 1x X2X Link Interface - 1x POWERLINK interface - 512 kB nvSRAM - For APC2100/PPC2100/APC2200/PPC2200 - Only available with a new device	73
5ACCIF01.FSS0-000	Interface card - 2x RS422/RS485 interface - For APC2100/PPC2100/APC2200/PPC2200 - Only available with a new device	78
5ACCIF01.ICAN-000	Interface card - 1x CAN interface - For APC2100/PPC2100/APC2200/PPC2200 - Only available with a new device	82
5ACCIF01.IS00-000	Interface card - 1x RS232 interface - For APC2100/PPC2100/APC2200/PPC2200 - Only available with a new device	85
	Linux for B&R 8	
5SWLIN.0542-MUL	Linux for B&R 8 - 32-bit - Multilingual - APC2100 Bay Trail chipset - Installation - Only available with a new device	151
5SWLIN.0642-MUL	Linux for B&R 8 - 64-bit - Multilingual - APC2100 Bay Trail chipset - Installation - Only available with a new device	151
	Linux for B&R 9	
5SWLIN.0742-MUL	Linux for B&R 9 - 64-bit - Multilingual - APC2100 Bay Trail chipset - Installation - Only available with a new device	153
	Monitor/Panel options	
5ACCLI01.SDL0-000	Monitor/Panel option - 1x SDL/DVI transmitter - For APC2100/APC2200 - Only available with a new device	46
5ACCLI01.SDL3-000	Monitor/Panel option - 1x SDL3 transmitter - For APC2100 - Only available with a new device	49
	Other	
5ACCRHMI.0006-000	HMI installation tool for control cabinet - 1x torque wrench 0.4 - 2.0 Nm - 1x hex head bit 2.5, length 89 mm - 1x hex head bit 3.0, length 89 mm - 1x hex head bit 5.0, length 89 mm - 1x Torx 10 bit, length 90 mm - 1x Torx 20 bit, length 89 mm	172
	System units	
5APC2100.BY01-000	APC2100 system unit - Intel Atom E3815 1.46 GHz - Single core - 1 GB SDRAM	43
5APC2100.BY11-000	APC2100 system unit - Intel Atom E3825 1.33 GHz - Dual core - 1 GB SDRAM	43
5APC2100.BY22-000	APC2100 system unit - Intel Atom E3826 1.46 GHz - Dual core - 2 GB SDRAM	43
5APC2100.BY34-000	APC2100 system unit - Intel Atom E3827 1.75 GHz - Dual core - 4 GB SDRAM	43
5APC2100.BY44-000	APC2100 system unit - Intel Atom E3845 1.91 GHz - Quad core - 4 GB SDRAM	43
5APC2100.BY48-000	APC2100 system unit - Intel Atom E3845 1.91 GHz - Quad core - 8 GB SDRAM	43
	Technology Guard	
0TG1000.01	Technology Guard (MSD)	147
0TG1000.02	Technology Guard (HID)	147
1TG4600.10-5	Automation Runtime Windows TG license	147
1TG4601.06-5	Automation Runtime Embedded, TG license	147
	Terminal blocks	
0TB1210.3100	Connector 300 VDC - 10-pin female - Cage clamp terminal block - Protected against vibration by the screw flange	174
	Windows 10 IoT Enterprise 2015 LTSB	
5SWW10.0242-MUL	Windows 10 IoT Enterprise 2015 LTSB - 64-bit - Multilingual - APC2100 chipset Bay Trail - License (without Recovery DVD) - Only available with a new device	137
	Windows 10 IoT Enterprise 2016 LTSB	
5SWW10.0542-MUL	Windows 10 IoT Enterprise 2016 LTSB - 64-bit - Entry - Multilingual - APC2100 chipset Bay Trail - Processor E3826/E3827/E3845 - License - Only available with a new device	134
	Windows 7 Professional/Ultimate	
5SWWI7.1100-ENG	Windows 7 Professional SP1 - 32-bit - English - DVD	143
5SWWI7.1100-GER	Windows 7 Professional SP1 - 32-bit - German - DVD	143
5SWWI7.1200-ENG	Windows 7 Professional SP1 - 64-bit - English - DVD	143
5SWWI7.1200-GER	Windows 7 Professional SP1 - 64-bit - German - DVD	143
5SWWI7.1300-MUL	Windows 7 Ultimate SP1 - 32-bit - Multilingual - DVD	143

Order number	Short description	Page
5SWWI7.1400-MUL	Windows 7 Ultimate SP1 - 64-bit - Multilingual - DVD	143
	Windows Embedded 8.1 Industry Pro	
5SWWI8.0342-MUL	Windows Embedded 8.1 Industry Pro - 32-bit - Multilingual - For the APC2100 - License	140
5SWWI8.0442-MUL	Windows Embedded 8.1 Industry Pro - 64-bit - Multilingual - For the APC2100 - License	140
	Windows Embedded Standard 7	
5SWWI7.1542-ENG	Windows Embedded Standard 7 SP1 - 32-bit - Service Pack 1 - English - APC2100 - License (without Recovery DVD) - Only available with a new device	145
5SWWI7.1642-ENG	Windows Embedded Standard 7 SP1 - 64-bit - Service Pack 1 - English - APC2100 - License (without Recovery DVD) - Only available with a new device	145
5SWWI7.1742-MUL	Windows Embedded Standard 7 Premium SP1 - 32-bit - Service Pack 1 - English - APC2100 - License (without Recovery DVD) - Only available with a new device	145
5SWWI7.1842-MUL	Windows Embedded Standard 7 Premium SP1 - 64-bit - Service Pack 1 - English - APC2100 - License (without Recovery DVD) - Only available with a new device	145

4 Technical data

4.1 Complete system

4.1.1 Connection options

An Automation Panel can be connected to the Automation PC with an optional monitor/panel option via DVI, SDL or SDL3. The connection options described in the following provide an overview of the operating modes and possible limitations.

Information:

In its minimum configuration, the APC2100 has no possibility to connect an external display (e.g. Automation Panel). In order to implement a display option, a monitor/panel option must be included in the configuration. This option can only be added at the B&R factory and cannot be retrofitted.

4.1.1.1 SDL operation

4.1.1.1.1 SDL operation without USB cable (mode 1)

With this connection option, all communication between the Automation Panel and B&R industrial PC takes place via a single SDL cable.

In addition to the display data, information from the touch screen, matrix keys, LEDs and service/diagnostic data is transferred. The Automation Panel can be installed up to 40 m away from the B&R industrial PC. USB 1.1 is also transferred over this distance and fully integrated into SDL. External adapter modules are not required.

The brightness of the display can be set via the ADI Control Center, for example.

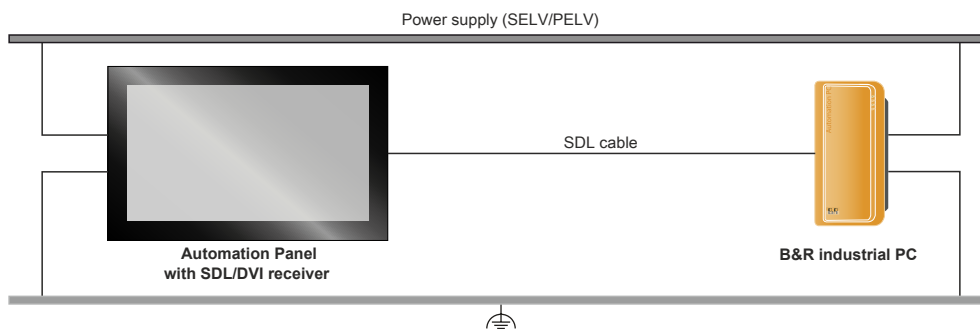

Availability of the interfaces on the Automation Panel with SDL/DVI receiver:

Panel In	✓	USB In	✗	Power supply	✓	Brightness controls	✗
USB1, USB2	✓	COM interface for touch screen	✗	Grounding	✓		

Maximum cable length: 40 m

Requirements

- Automation Panel with SDL/DVI receiver
- B&R industrial PC with SDL interface
- SDL cable

4.1.1.1.2 SDL operation with USB cable (mode 2)

With this connection option, communication between the Automation Panel and B&R industrial PC takes place via an SDL cable that is connected to interface "Panel In" and a USB type A/B cable that is connected to interface "USB In".

Display data as well as information from the resistive touch screen keys, matrix keys, LEDs and service/diagnostic data is transferred via the SDL cable. The touch screen data from the multi-touch screen is transferred via the USB type A/B cable. The Automation Panel can be installed up to 5 m (USB specification) away from the B&R industrial PC. USB 2.0 can be transferred over this distance via the USB type A/B cable. External adapter modules are not required.

The brightness of the display can be set via the ADI Control Center, for example.

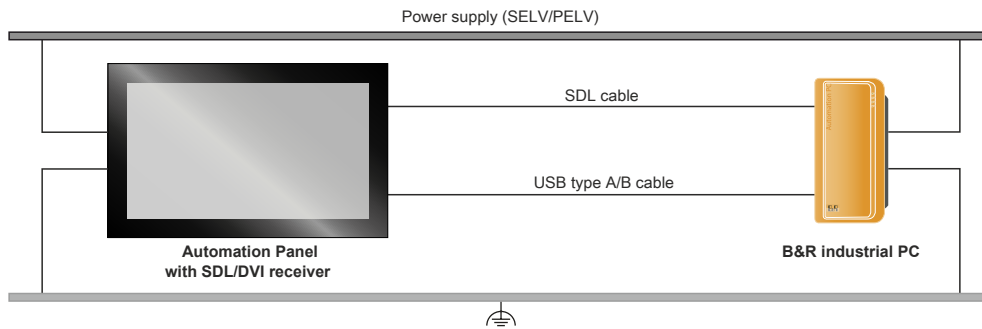

Availability of the interfaces on the Automation Panel with SDL/DVI receiver:

Panel In	✓	USB In	✓	USB 2.0	✓	Power supply	✓	Brightness controls	✗
USB1, USB2	✓	USB 2.0	✗	COM interface for touch screen	✗	Grounding	✓		

Maximum cable length: 5 m

Requirements

- Automation Panel with SDL/DVI receiver
- B&R industrial PC with SDL interface
- SDL cable, USB type A/B cable

4.1.1.2 DVI operation

In DVI operation, all signals needed to operate the Automation Panel are transferred via a separate cable. The brightness of the display can be set using the brightness buttons.

4.1.1.2.1 DVI operation with single-touch Automation Panel

If an Automation Panel with resistive touch screen (single-touch) is operated with DVI, a DVI, USB type A/B and RS232 cable must be connected.

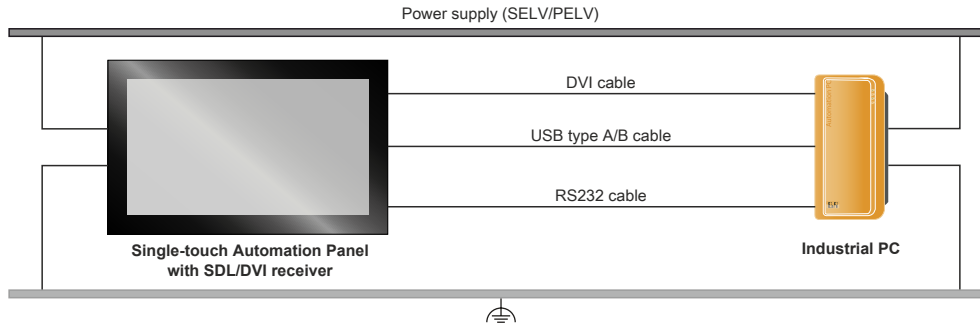

Availability of the interfaces on the Automation Panel with SDL/DVI receiver:

Panel In	✓	USB In	✓	Power supply	✓	Brightness controls	✓
USB1, USB2	✓	COM interface for touch screen	✓	Grounding	✓		

Maximum cable length: 5 m

Requirements

- Automation Panel with SDL/DVI receiver
- Industrial PC with DVI interface
- DVI cable, USB type A/B cable, RS232 cable

4.1.1.2.2 DVI operation with multi-touch Automation Panel

If an Automation Panel with PCT touch screen (multi-touch) is operated with DVI, a DVI and USB type A/B cable must be connected.

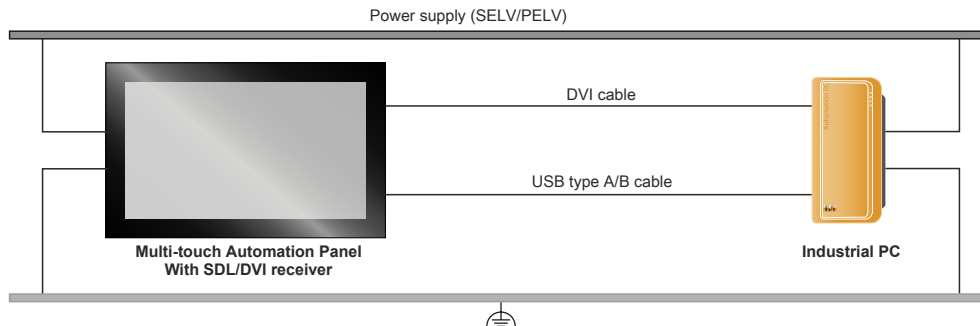

Availability of the interfaces on the Automation Panel with SDL/DVI receiver:

Panel In	✓	USB In	✓	Power supply	✓	Brightness controls	✓
USB1, USB2	✓	COM interface for touch screen	x	Grounding	✓		

Maximum cable length: 5 m

Requirements

- Automation Panel with SDL/DVI receiver
- Industrial PC with DVI interface
- DVI cable, USB type A/B cable

4.1.1.2.3 General limitations

- Key and LED data is not transferred.
- Service and diagnostic data is not transferred.

- Updating the firmware of Automation Panels is not possible.
- The maximum cable length is limited to 5 m.

4.1.1.3 SDL3 operation

Smart Display Link 3 (SDL3) technology transfers all communication channels between a B&R industrial PC and panel up to 100 m over a standard Ethernet cable (min. Cat 6a). An RJ45 connector is used for the device connection, which is ideal for confined spaces in feed-throughs and swing arm systems.

4.1.1.3.1 SDL3 operation with SDL3 transmitter

In SDL3 operation with an SDL3 transmitter in the B&R industrial PC, all communication between the Automation Panel and B&R industrial PC takes place via a single SDL3 cable.

In addition to the display data, information from the touch screen, matrix keys, LEDs and service/diagnostic data is transferred. The Automation Panel can be installed up to 100 m away from the B&R industrial PC. USB 2.0 is also transferred over this distance and fully integrated into SDL3. External adapter modules are not required.

The brightness of the display can be set via the ADI Control Center.

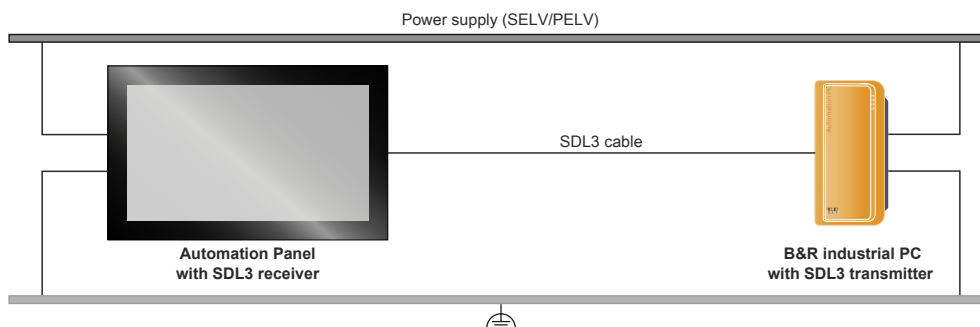

Availability of interfaces on Automation Panels with an SDL3 receiver:

SDL3 interface ✓ USB1, USB2 ✓ USB 2.0 Power supply ✓ Grounding ✓

Maximum cable length for SDL3: 100 m

Requirements

- Automation Panel with SDL3 receiver
- B&R industrial PC with SDL3 interface
- SDL3/SDL4 cable

4.1.1.3.2 General limitations/characteristics

- USB 2.0 transfer is limited to 30 Mbit/s with SDL3.
- A display is always emulated by the SDL3 transmitter using EDID data and hot plug detection, so DVI-compatible operation is possible. For this reason, the following behavior may occur during operation with multiple displays. In the operating system, a connected panel is reported by the video driver even in the following situations:
 - No SDL3/SDL4 cable is connected.
 - There is no connection established yet between the SDL3 link module and SDL3 transmitter.

This behavior can be avoided by appropriate configuration in BIOS or via the graphics driver.

4.1.2 Mechanical properties

4.1.2.1 Dimensions

Information:

All specifications in dimension diagrams and associated tables are in millimeters [mm].

2D and 3D diagrams (DXF and STEP formats) can be downloaded from the B&R website (www.br-automation.com).

Mounting plate on the back (book style)

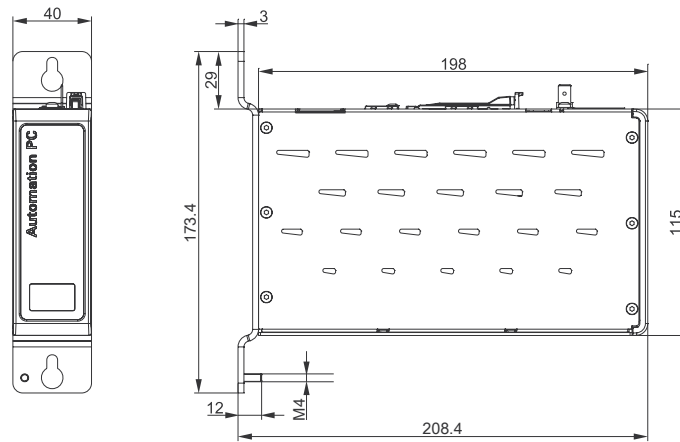

Mounting plate on the side (box style)

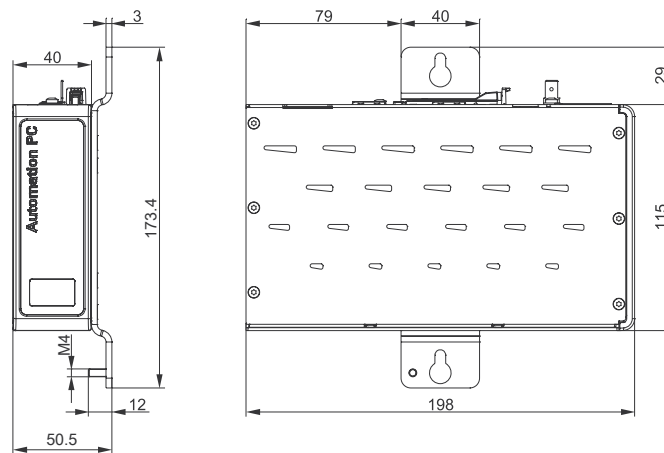

4.1.2.2 Drilling template

Information:

When installing the APC 2100, spacing for air circulation and additional free space for operating and servicing the device must be taken into account.

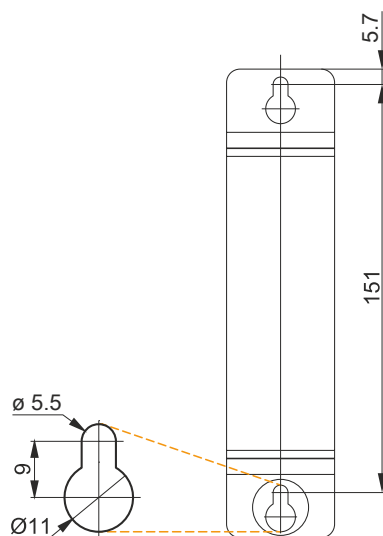

4.1.2.3 Spacing for air circulation

To ensure sufficient air circulation, a specified clearance must be provided above, below, to the side and behind the device. For the minimum specified clearance, see the following diagrams. This is valid for all variants.

Information:

The following figure and table exclusively show the thermal view of the complete system. If additional space is required for operating or servicing the device, this must be taken into account during installation.

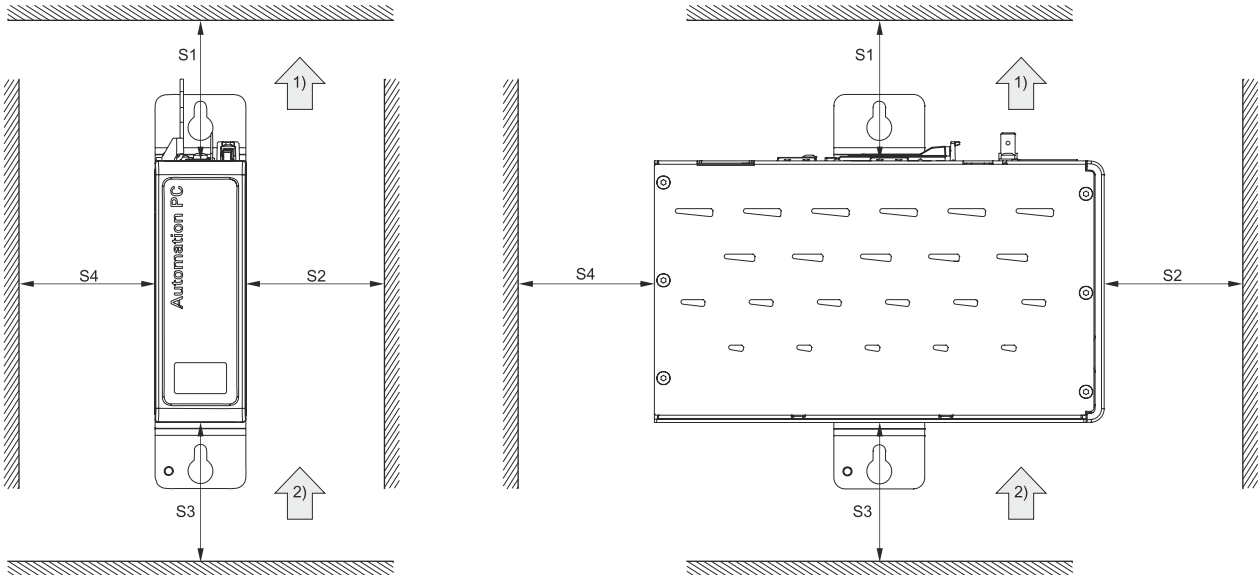

Legend			
1)	Air outlet	2)	Air inlet
Name	Dimension	Name	Dimension
S1	≥100	S2	≥50
S3	≥100	S4	≥50

Caution!

The specified spacing for air circulation is based on worst-case operation at the maximum specified ambient temperature. The maximum specified ambient temperature is not permitted to be exceeded!

If the specified spacing for air circulation cannot be maintained, the maximum specified temperatures of the temperature sensors (see "[Temperature sensor positions](#)" on page 32) must be monitored by the user and appropriate measures taken if these values are exceeded.

4.1.2.4 Mounting orientations

To achieve natural air circulation, it is important to ensure that the clearance values specified in section "Spacing for air circulation" on page 27 are observed during installation.

Mounting plate on back (book style)

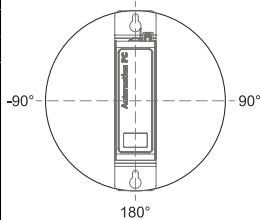
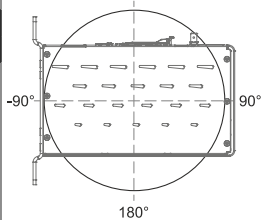
Book style	Inclination [°]	Derating [°C]	Book style	Inclination [°]	Derating
	0 to ±5	No limitation		0 to ±5	No limitation
	±5 to ±175	-5		5 to 175	Not allowed!
	±175 to 180	No limitation		-5 to -175	-5
				±175 to 180	No limitation

Mounting plate on right side (box style)

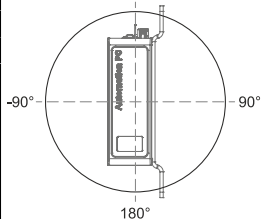
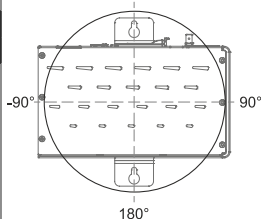
Box style	Inclination [°]	Derating [°C]	Box style	Inclination [°]	Derating [°C]
	0 to ±5	No limitation		0 to ±5	No limitation
	±5 to ±175	Not allowed!		5 to 175	Not allowed!
	±175 to 180	No limitation		-5 to -175	-5
				±175 to 180	No limitation

4.1.2.5 Weight specifications

System units and components

Type	Model number	Weight [g]
System units	5APC2100.BYxx-000	1170
CFast cards	5CFAST.xxxx-00	10
	5CFAST.xxxx-10	10
Monitor/Panel options	5ACCLI01.SDL0-000	20
	5ACCLI01.SDL3-000	20
Interface options	5ACCIF01.FPCC-000	25
	5ACCIF01.FPCS-000	25
	5ACCIF01.FPLK-000	25
	5ACCIF01.FPLS-000	25
	5ACCIF01.FPLS-001	25
	5ACCIF01.FPSC-000	25
	5ACCIF01.FPSC-001	25
	5ACCIF01.FSS0-000	25
	5ACCIF01.ICAN-000	25
	5ACCIF01.IS00-000	25

4.1.3 Environmental properties

4.1.3.1 Temperature specifications

Because it is possible to combine different system units with a monitor/panel option and interface option, the following tables provide a component-dependent overview of the maximum, minimum and typical possible ambient temperatures resulting from these combinations.

Information:

The minimum and maximum specified ambient temperatures were determined under worst-case conditions for operation. Experience has shown that higher ambient temperatures can be achieved with typical applications in Microsoft Windows, for example. The relevant test and assessment must be carried out individually by the user on site (reading out the temperatures in BIOS or using the ADI Control Center, for example).

Information regarding worst-case conditions

- Thermal Analysis Tool (TAT) from Intel for simulating the processor utilization (CPU 100%, memory 100%, graphics 100%)
- BurnInTest from PassMark Software for simulating 100% interface utilization using loopback adapters (100% network)
- Maximum system expansion and power consumption

4.1.3.1.1 Maximum ambient temperature for worst-case operation

All temperature specifications in degrees Celsius [°C] at 500 m above sea level, non-condensing . The respective ambient temperature is typically derated 1°C per 1000 meters starting at 500 m above sea level.		Maximum ambient temperature (system unit 5APC2100.BYxx-000)					
		5APC2100. BY01-000 (E3815 1.46 GHz)	5APC2100. BY11-000 (E3825 1.33 GHz)	5APC2100. BY22-000 (E3826 1.46 GHz)	5APC2100. BY34-000 (E3827 1.75 GHz)	5APC2100. BY44-000 (E3845 1.91 GHz)	5APC2100. BY48-000 (E3845 1.91 GHz)
Maximum ambient temperature (accessories)		55	55	55	50	50	50
CFast cards	5CFast.xxxx-00 ≥ Rev. E0	✓	✓	✓	✓	✓	✓
	5CFast.xxxx-10	✓	✓	✓	✓	✓	✓
Monitor/Panel options	5ACLI01.SDL0-000	✓	✓	✓	✓	✓	✓
	5ACLI01.SDL3-000	50	50	50	✓	45	45
Interface options	5ACCIF01.FPCC-000	✓	✓	✓	✓	✓	✓
	5ACCIF01.FPCS-000	✓	✓	✓	✓	✓	✓
	5ACCIF01.FPLK-000	✓	✓	✓	✓	✓	✓
	5ACCIF01.FPLS-000	✓	✓	✓	✓	✓	✓
	5ACCIF01.FPLS-001	✓	✓	✓	✓	✓	✓
	5ACCIF01.FPSC-000	✓	✓	✓	✓	✓	✓
	5ACCIF01.FPSC-001	✓	✓	✓	✓	✓	✓
	5ACCIF01.FSS0-000	✓	✓	✓	✓	✓	✓
	5ACCIF01.ICAN-000	✓	✓	✓	✓	✓	✓
	5ACCIF01.IS00-000	✓	✓	✓	✓	✓	✓

4.1.3.1.2 Minimum ambient temperature for worst-case operation

All temperature specifications in degrees Celsius [°C] at 500 m above sea level, non-condensing .		Minimum ambient temperature (system unit 5APC2100.BYxx-000)					
		5APC2100. BY01-000 (E3815 1.46 GHz)	5APC2100. BY11-000 (E3825 1.33 GHz)	5APC2100. BY22-000 (E3826 1.46 GHz)	5APC2100. BY34-000 (E3827 1.75 GHz)	5APC2100. BY44-000 (E3845 1.91 GHz)	5APC2100. BY48-000 (E3845 1.91 GHz)
		-20	-20	-20	-20	-20	-20
Minimum ambient temperature (accessories)							
CFast cards	5CFAST.xxxx-00 ≥ Rev. E0	✓	✓	✓	✓	✓	✓
	5CFAST.xxxx-10	✓	✓	✓	✓	✓	✓
Monitor/Panel options	5ACCLI01.SDL0-000 ¹⁾	✓	✓	✓	✓	✓	✓
	5ACCLI01.SDL3-000	0	0	0	0	0	0
Interface options	5ACCIF01.FPCC-000	✓	✓	✓	✓	✓	✓
	5ACCIF01.FPCS-000	✓	✓	✓	✓	✓	✓
	5ACCIF01.FPLK-000	✓	✓	✓	✓	✓	✓
	5ACCIF01.FPLS-000	✓	✓	✓	✓	✓	✓
	5ACCIF01.FPLS-001	✓	✓	✓	✓	✓	✓
	5ACCIF01.FPSC-000	✓	✓	✓	✓	✓	✓
	5ACCIF01.FPSC-001	✓	✓	✓	✓	✓	✓
	5ACCIF01.FSS0-000	✓	✓	✓	✓	✓	✓
	5ACCIF01.ICAN-000	✓	✓	✓	✓	✓	✓
	5ACCIF01.IS00-000	✓	✓	✓	✓	✓	✓

1) RGB operation is possible down to a minimum of 0°C.

4.1.3.1.3 Maximum ambient temperature for typical operation

Information about typical conditions

- BurnInTest V7.1 from PassMark Software for simulating moderate system and interface utilization using loopback adapters
- No permanent 100% processor utilization and graphics utilization
- 2x Gigabit Ethernet
- The total power of all USB interfaces is limited to 1 W.
- The power consumption of the complete system is limited to 45 W. For the power consumption of individual components, see "[Power calculation](#)" on page 35.

All temperature specifications in degrees Celsius [°C] at 500 m above sea level, non-condensing .		Maximum ambient temperature (system unit 5APC2100.BYxx-000)					
		5APC2100. BY01-000 (E3815 1.46 GHz)	5APC2100. BY11-000 (E3825 1.33 GHz)	5APC2100. BY22-000 (E3826 1.46 GHz)	5APC2100. BY34-000 (E3827 1.75 GHz)	5APC2100. BY44-000 (E3845 1.91 GHz)	5APC2100. BY48-000 (E3845 1.91 GHz)
The respective ambient temperature is typically derated 1°C per 1000 meters starting at 500 m above sea level.		60	60	60	55	55	55
Maximum ambient temperature (accessories)							
CFast cards	5CFAST.xxxx-00 ≥ Rev. E0	55	55	55	✓	✓	✓
	5CFAST.xxxx-10	55	55	55	✓	✓	✓
Monitor/Panel options	5ACCLI01.SDL0-000	✓	✓	✓	✓	✓	✓
	5ACCLI01.SDL3-000	55	55	55	50	50	50
Interface options	5ACCIF01.FPCC-000	✓	✓	✓	✓	✓	✓
	5ACCIF01.FPCS-000	✓	✓	✓	✓	✓	✓
	5ACCIF01.FPLK-000	✓	✓	✓	✓	✓	✓
	5ACCIF01.FPLS-000	✓	✓	✓	✓	✓	✓
	5ACCIF01.FPLS-001	✓	✓	✓	✓	✓	✓
	5ACCIF01.FPSC-000	✓	✓	✓	✓	✓	✓
	5ACCIF01.FPSC-001	✓	✓	✓	✓	✓	✓
	5ACCIF01.FSS0-000	✓	✓	✓	✓	✓	✓
	5ACCIF01.ICAN-000	✓	✓	✓	✓	✓	✓
	5ACCIF01.IS00-000	✓	✓	✓	✓	✓	✓

4.1.3.1.4 How to determine the maximum, minimum and typical ambient temperatures

1. Select the system unit.
2. The columns specify the maximum or minimum temperature in worst-case operation or the maximum temperature in typical operation of the complete system depending on the respective system unit.

Information:

The maximum and typical temperature specifications correspond to a specification at 500 meters above sea level. The respective ambient temperature is derated approx. 1°C per 1000 meters starting at 500 m above sea level.

3. If interface options and CFast cards are additionally installed in the APC2100 system, they may result in a temperature limitation.
 - If a "✓" (check mark) is entered for the installed component, it can be operated without any problems.
 - If the installed component has a temperature specification (e.g. "45[°C]"), the ambient temperature of the complete system is not permitted to exceed this value.
4. Possible limitations may arise due to the mounting orientation of APC2100. For additional information, see section "Mounting orientations" on page 28.
5. The relevant test and assessment must be carried out individually by the user on site (reading out the temperatures in BIOS or using the B&R Control Center). See section "Information about typical conditions" on page 30.

4.1.3.1.5 Ambient temperature for storage and transport

The following table provides an overview of the minimum and maximum ambient temperatures for storing and transporting the complete system. Limitations are possible due to individual components.

System units and components

Type	Model number	Storage [°C]	Transport [°C]
System units	5APC2100.BYxx-000	-20 to 60	-20 to 60
	5CFAST.xxxx-00	-50 to 100	-50 to 100
CFast cards	5CFAST.032G-10 ≥Rev. G0	-40 to 85	-40 to 85
	5CFAST.032G-10 ≤Rev. F0	-55 to 95	-55 to 95
	5CFAST.064G-10 ≥Rev. E0	-40 to 85	-40 to 85
	5CFAST.064G-10 ≤Rev. D0	-55 to 95	-55 to 95
	5CFAST.128G-10 ≥Rev. E0	-40 to 85	-40 to 85
	5CFAST.128G-10 ≤Rev. D0	-55 to 95	-55 to 95
Monitor/Panel options	5ACCLI01.SDL0-000	-20 to 60	-20 to 60
	5ACCLI01.SDL3-000	-20 to 60	-20 to 60
Interface options	5ACCIF01.FPCC-000	-20 to 60	-20 to 60
	5ACCIF01.FPCS-000	-20 to 60	-20 to 60
	5ACCIF01.FPLK-000	-20 to 60	-20 to 60
	5ACCIF01.FPLS-000	-20 to 60	-20 to 60
	5ACCIF01.FPLS-001	-20 to 60	-20 to 60
	5ACCIF01.FPSC-000	-20 to 60	-20 to 60
	5ACCIF01.FPSC-001	-20 to 60	-20 to 60
	5ACCIF01.FSS0-000	-20 to 60	-20 to 60
	5ACCIF01.ICAN-000	-20 to 60	-20 to 60
	5ACCIF01.IS00-000	-20 to 60	-20 to 60

4.1.3.1.6 Temperature monitoring

Sensors monitor temperature values at various areas in the APC2100. For the position of temperature sensors, see section "Temperature sensor positions" on page 32. The values specified there represent the defined maximum temperature at this measuring point. If the temperature is exceeded, no alarm is triggered.

Temperatures²⁾ can be read out in different ways in approved operating systems:

- BIOS
- ADI Control Center
- ADI Development Kit
- ADI .NET SDK
- B&R HMI Service Center
- B&R HMI Report
- ADI OPC UA Server
- Automation Runtime library

The CFast cards available from B&R are equipped with S.M.A.R.T support³⁾. Various parameters (e.g. temperature) can be read out in approved Microsoft Windows or Linux for B&R operating systems.

4.1.3.1.7 Temperature sensor positions

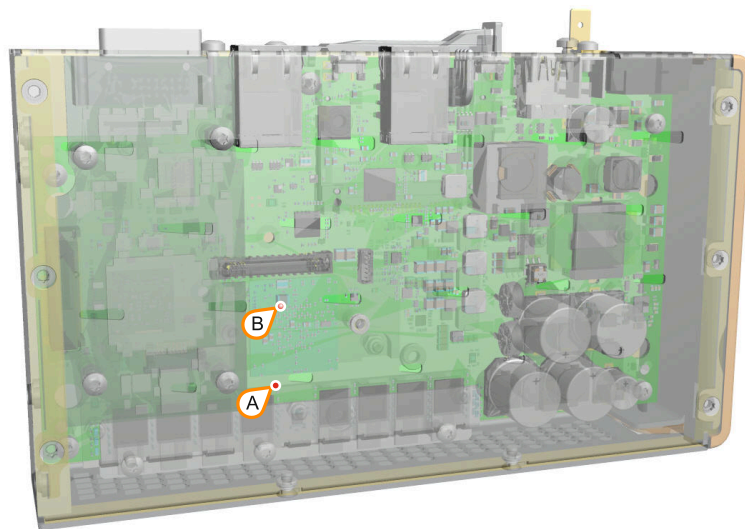

ADI sensors	Position	Measurement point for	Measurement	Max. specified
System unit sensor 2	B	CPU	Temperature of the processor area (sensor integrated on the CPU board).	95°C
System unit sensor 1	A	Main memory	Temperature of the main memory area (sensor integrated on the CPU board).	95°C

²⁾ The measured temperature is a guide value for the immediate ambient temperature, but it may have been influenced by neighboring components.

³⁾ Self-Monitoring, Analysis and Reporting Technology

4.1.3.2 Relative humidity

The following tables show the minimum and maximum relative humidity (at 30°C, non-condensing) of the individual components that are relevant for limiting the humidity of the complete system. The smallest or largest value must always be used for this determination. For more detailed information, see technical data or temperature/humidity diagrams of the individual components.

System unit and components

Type	Order number	Operation [%]	Storage [%]	Transport [%]
System units	5APC2100.BYxx-000	5 to 90	5 to 95	5 to 95
CFast cards	5CFAST.xxxx-00	Max. 85% at 85°C	Max. 85% at 85°C	Max. 85% at 85°C
	5CFAST.032G-10 ≥ Rev. G0	Max. 85% at 85°C	Max. 85% at 85°C	Max. 85% at 85°C
	5CFAST.032G-10 ≤ Rev. F0	10 to 95	10 to 95	10 to 95
	5CFAST.064G-10 ≥ Rev. E0	Max. 85% at 85°C	Max. 85% at 85°C	Max. 85% at 85°C
	5CFAST.064G-10 ≤ Rev. D0	10 to 95	10 to 95	10 to 95
	5CFAST.128G-10 ≥ Rev. E0	Max. 85% at 85°C	Max. 85% at 85°C	Max. 85% at 85°C
	5CFAST.128G-10 ≤ Rev. D0	10 to 95	10 to 95	10 to 95
Monitor/Panel options	5ACCLI01.SDL0-000	5 to 90	5 to 95	5 to 95
	5ACCLI01.SDL3-000	5 to 90	5 to 95	5 to 95
Interface options	5ACCIF01.FPCC-000	5 to 90	5 to 95	5 to 95
	5ACCIF01.FPCS-000	5 to 90	5 to 95	5 to 95
	5ACCIF01.FPLK-000	5 to 90	5 to 95	5 to 95
	5ACCIF01.FPLS-000	5 to 90	5 to 95	5 to 95
	5ACCIF01.FPLS-001	5 to 90	5 to 95	5 to 95
	5ACCIF01.FPSC-000	5 to 90	5 to 95	5 to 95
	5ACCIF01.FPSC-001	5 to 90	5 to 95	5 to 95
	5ACCIF01.FSS0-000	5 to 90	5 to 95	5 to 95
	5ACCIF01.ICAN-000	5 to 90	5 to 95	5 to 95
	5ACCIF01.IS00-000	5 to 90	5 to 95	5 to 95

4.1.3.3 Vibration

The following table provides an overview of the maximum vibration values of the complete system. Limitations are possible due to individual components.

Automation PC	Operation ¹⁾		Storage ¹⁾²⁾	Transport ¹⁾²⁾
	Continuous	Periodic		
With CFast card	2 to 9 Hz: 1.75 mm amplitude 9 to 200 Hz: 0.5 g	2 to 9 Hz: 3.5 mm amplitude 9 to 200 Hz: 1 g	2 to 8 Hz: 7.5 mm amplitude 8 to 200 Hz: 2 g 200 to 500 Hz: 4 g	2 to 8 Hz: 7.5 mm amplitude 8 to 200 Hz: 2 g 200 to 500 Hz: 4 g

1) Testing is performed per EN 60068-2-6.

2) The specification refers to a device in its original packaging.

4.1.3.4 Shock

The following table provides an overview of the maximum shock values of the complete system. Limitations are possible due to individual components.

Automation PC	Operation ¹⁾	Storage ¹⁾²⁾	Transport ¹⁾²⁾
With CFast card	15 g, 11 ms	30 g, 6 ms	30 g, 6 ms

1) Testing is performed per EN 60068-2-27.

2) The specification refers to a device in its original packaging.

4.1.3.5 Degree of protection

Under the following conditions, the Automation PC 2100 offers IP20 protection per EN 60529:

- Correct installation of the Automation PC 2100 (see "[Installation and wiring](#)" on page 89)
- All covers or components are installed on the interfaces and slots.
- All environmental conditions are being observed.

4.1.4 Electrical properties

4.1.4.1 System units (5APC2100.BYxx-000) - Block diagram

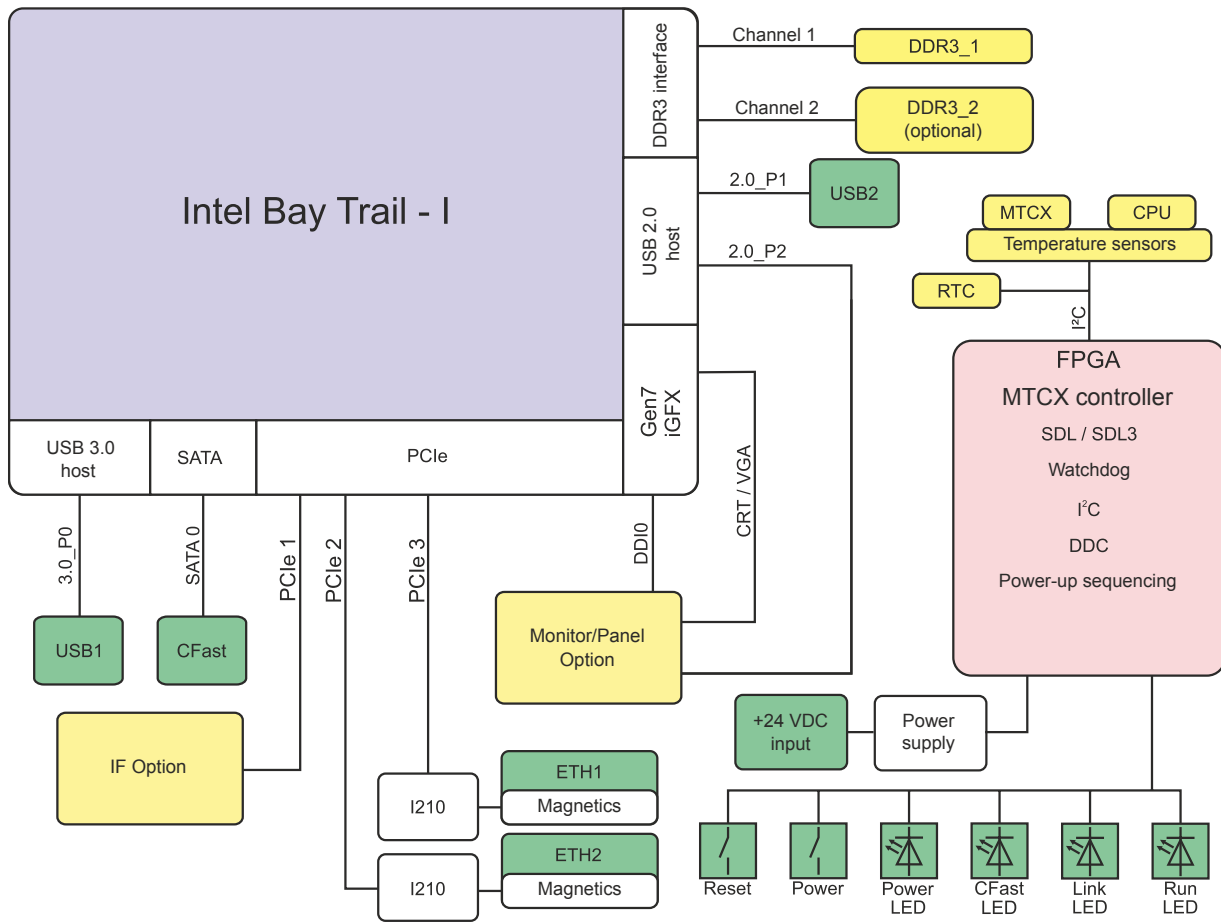

Legend			
	Internal interface	2.0_Px	USB 2.0 port x
	External interface	3.0_Px	USB 3.0 port x

4.1.4.2 Power calculation

To calculate the total power of the Automation PC 2100, the power ratings of the system unit used must be added to the power ratings of the individual components used.

Information:

Unless otherwise specified, the following values are maximum values and additional consumers (e.g. USB devices) are not taken into account.

System units

Type	Model number	Total power consumption
APC2100 E3815 1C 1.46 GHz	5APC2100.BY01-000	12 W (without USB consumer) 22 W (with USB consumer)
APC2100 E3825 2C 1.33 GHz	5APC2100.BY11-000	13 W (without USB consumer) 23 W (with USB consumer)
APC2100 E3826 2C 1.46 GHz	5APC2100.BY22-000	15 W (without USB consumer) 25 W (with USB consumer)
APC2100 E3827 2C 1.75 GHz	5APC2100.BY34-000	17 W (without USB consumer) 27 W (with USB consumer)
APC2100 E3845 4C 1.91 GHz	5APC2100.BY44-000	19 W (without USB consumer) 29 W (with USB consumer)
APC2100 E3845 4C 1.91 GHz	5APC2100.BY48-000	20 W (without USB consumer) 30 W (with USB consumer)

Monitor/Panel options

Type	Model number	+5 V	+3.3 V	+12 V	Total power consumption
SDL/DVI transmitter	5ACCLI01.SDL0-000	0.25 W	0.75 W	-	1.00 W
SDL3 transmitter	5ACCLI01.SDL3-000	2.20 W	1.80 W	-	4.00 W

Interface options

Type	Order number	+5 V	+3.3 V	+12 V	Total power consumption
POWERLINK CAN X2X	5ACCIF01.FPCC-000	0.45 W	1.55 W	-	2.00 W
POWERLINK RS485 CAN	5ACCIF01.FPCS-000	0.75 W	1.00 W	-	1.75 W
POWERLINK	5ACCIF01.FPLK-000	-	1.75 W	-	1.75 W
POWERLINK RS232	5ACCIF01.FPLS-000	0.50 W	1.00 W	-	1.50 W
POWERLINK RS232	5ACCIF01.FPLS-001	-	1.50 W	-	1.50 W
POWERLINK RS232 CAN	5ACCIF01.FPSC-000	0.75 W	1.00 W	-	1.75 W
POWERLINK RS232 CAN X2X	5ACCIF01.FPSC-001	0.60 W	1.40 W	-	2.00 W
2x RS422/RS485	5ACCIF01.FSS0-000	0.80 W	0.20 W	-	1.00 W
CAN	5ACCIF01.ICAN-000	0.45 W	0.05 W	-	0.50 W
RS232	5ACCIF01.IS00-000	-	0.50 W	-	0.50 W

CFast cards

Type	Order number	+5 V	+3.3 V	+12 V	Total power consumption
SLC technology	5CFAST.xxxx-00	-	0.7 W read 0.7 W write 0.3 W idle	-	0.7 W read 0.7 W write 0.3 W idle
MLC technology	5CFAST.032G-10 ≥ G0 5CFAST.064G-10 ≥ E0	-	1.1 W read 1 W write 0.25 W idle	-	1.1 W read 1 W write 0.25 W idle
	5CFAST.128G-10 ≥ E0	-	1.1 W read 1.4 W write 0.25 W idle	-	1 W read 1.4 W write 0.25 W idle
	5CFAST.032G-10 ≤ F0 5CFAST.064G-10 ≤ D0 5CFAST.128G-10 ≤ D0	-	0.8 W read 1 W write 0.4 W idle	-	0.8 W read 1 W write 0.4 W idle
	5CFAST.256G-10	-	1.2 W read 1.9 W write 0.25 W idle	-	1.2 W read 1.9 W write 0.25 W idle

4.1.4.2.1 Calculation example

System unit 5APC2100.BY11-000	23 W (with USB consumer)	23 W
Monitor/Panel option 5ACCLI01.SDL0-000	0.25 W + 0.75 W	1 W
Interface option 5ACCIF01.FPCS-000	0.75 W + 1.00 W	1.75 W
CFast card 5CFAST.128G-10 ≥ E0	1.4 W (read)	1.4 W
Total max.:		27.15 W

4.1.5 Device interfaces and slots

4.1.5.1 Device interface overview

Information:

The interfaces available on the device or module are numbered for the purpose of clear differentiation. The numbering used by the operating system may deviate, however.

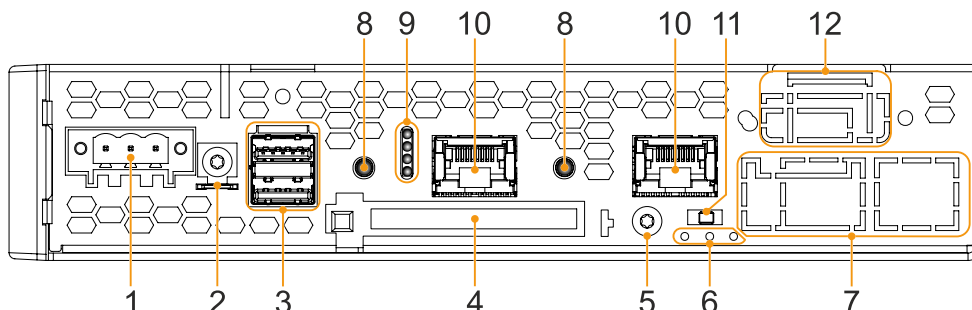

Legend			
1	"+24 VDC power supply" on page 36	7	"IF option slot(IF1, IFx)" on page 41
2	"Grounding" on page 37	8	"Power and reset buttons" on page 39
3	"USB interfaces" on page 38	9	"LED status indicators" on page 40
4	"CFAST slot" on page 39	10	"Ethernet interfaces" on page 37
5	Screw point for cable shield	11	IF option terminating resistor switch ¹⁾
6	IF option - LED status indicators ¹⁾	12	"Monitor/Panel interface" on page 40 ²⁾

- 1) Only available with installed interface option (configuration-dependent, see "Interface options").
- 2) Only available with installed monitor/panel option (configuration-dependent, see "Monitor/Panel options").

4.1.5.2 +24 VDC power supply

Danger!

This device is only permitted to be supplied with a SELV/PELV power supply unit or with safety extra-low voltage (SELV) per IEC 61010-2-201.

The necessary 3-pin connector is not included in delivery; for suitable accessories, see "0TB103.9x" on page 173.

The device is protected against overload and reverse polarity by a soldered fuse (10 A, fast-acting). If the fuse is defective (e.g. due to overload), the device must be sent to B&R for repairs. If the polarity is reversed, it is not necessary to replace the fuse.

Pin	Description	Figure
1	+	
2	Functional ground	
3	-	
<ul style="list-style-type: none"> • Reverse polarity protection • 3-pin • Male 		
Electrical properties		
Nominal voltage	24 VDC ±25%, SELV ¹⁾	
Nominal current	Max. 3.5 A	
Overvoltage category per EN 61131-2	II	
Inrush current	Typ. 6 A, max. 10 A for < 300 μs	
Galvanic isolation	Yes	
Uninterruptible power supply	No	

- 1) IEC 61010-2-201 requirements must be observed.

4.1.5.2.1 Grounding

Caution!

The functional ground (power supply pin 2 and ground connection) must be connected to the central grounding point (e.g. control cabinet or system) via the shortest possible path with the lowest possible resistance and with the largest possible wire cross section. This type of grounding is mandatory for proper functionality.

For example, a copper strip must be attached to the ground connection at a central grounding point of the control cabinet or system in which the device is installed. The wire cross section should be as large as possible (at least 2.5 mm²).

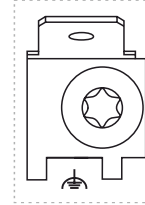

4.1.5.3 Ethernet interfaces

The Ethernet controller is routed externally via the system unit.

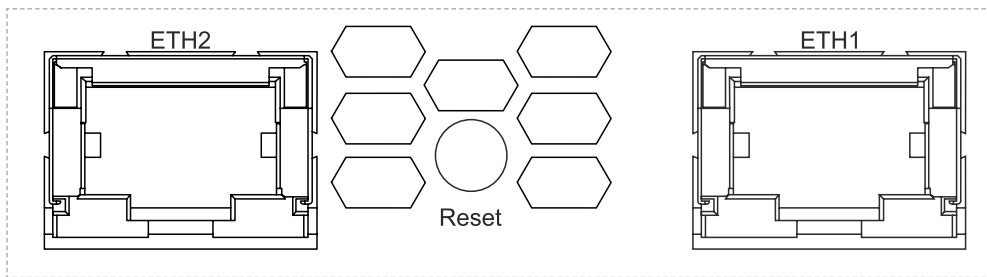

ETH1, ETH2		
Variant	RJ45, female	
Controller	Intel I210	
Wiring	S/STP (Cat 5e)	
Transfer rate	10/100/1000 Mbit/s ¹⁾	
Cable length	Max. 100 m (min. Cat 5e)	
LED "Speed" (b)	On	Off
Yellow	100 Mbit/s	10 Mbit/s ²⁾
Green	1000 Mbit/s	-
LED "Link" (a)	On	Active
Green	Link (a connection to an Ethernet network exists)	Blinking (data being transferred)

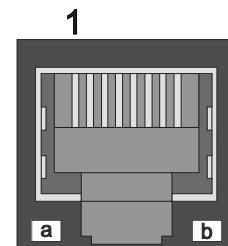

- 1) Switching takes place automatically.
- 2) The 10 Mbit/s transfer rate / connection is only available if LED "Link" is active at the same time.

Driver support

A special driver is required to operate the Ethernet controller. Drivers for approved operating systems are available for download in the Downloads section of the B&R website (www.br-automation.com).

Information:

Necessary drivers must be downloaded from the B&R website, not from manufacturer websites.

4.1.5.4 USB interfaces

The Automation PC 2100 is equipped with a Universal Serial Bus 3.0 (USB 3.0) host controller with several USB ports, of which one USB 3.0 interface and one USB 2.0 interface are routed externally and freely available to the user.

Warning!

USB peripheral devices can be connected to the USB interfaces. Due to the variety of USB devices available on the market, B&R cannot guarantee their functionality. The functionality of USB devices available from B&R is ensured.

Caution!

Due to the general PC specification, this interface must be handled with the utmost care with regard to EMC, cable routing, etc.

Driver support

A special driver is necessary to operate the USB 3.0 host controller with multiple USB ports. Drivers for approved operating systems are available for download in the Downloads section of the B&R website (www.br-automation.com).

Information:

Necessary drivers must be downloaded from the B&R website, not from manufacturer websites.

USB1 and USB2		
Standard	USB1	USB 3.0
	USB2	USB 2.0
Variant	Type A, female	
Transfer rate	Low speed (1.5 Mbit/s)	
	Full speed (12 Mbit/s)	
	High speed (480 Mbit/s)	
	SuperSpeed (5 Gbit/s) ¹⁾	
Current-carrying capacity ²⁾	Max. 1 A per connection	
Cable length	USB 2.0	Max. 5 m (without hub)
	USB 3.0	Max. 3 m (without hub)

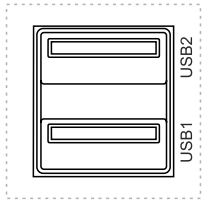

- 1) Compatibility with SuperSpeed depends on the operating system used and is only possible with USB 3.0.
- 2) Each USB interface is protected by a maintenance-free "USB current-limiting switch" (max. 1 A).

USB hub interfaces

4-port USB hub 5ACCUSB4.0000-000 provides up to 4 additional USB interfaces for the Panel PC 2100. For additional information, see section "USB hub" on page 175.

4.1.5.5 CFast slot

The Automation PC offers an easy-to-access CFast slot so that a CFast card can also be used as a removable storage medium for transferring data or performing upgrades.

This CFast slot is internally connected to the chipset and implemented in version SATA II (SATA 3.0 Gbit/s).

Information:

5CFAST.0xxx-00 CFast cards are only permitted to be operated in the xPC2100 with revision E0 or later.

CFast slot	
Connection	SATA 0
Order number	Short description
	CFast cards
5CFAST.2048-00	CFast 2 GB SLC
5CFAST.4096-00	CFast 4 GB SLC
5CFAST.8192-00	CFast 8 GB SLC
5CFAST.016G-00	CFast 16 GB SLC
5CFAST.032G-00	CFast 32 GB SLC
5CFAST.032G-10	CFast 32 GB MLC
5CFAST.064G-10	CFast 64 GB MLC
5CFAST.128G-10	CFast 128 GB MLC
5CFAST.256G-10	CFast 256 GB MLC

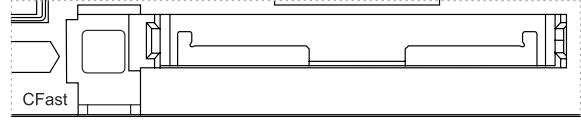

Warning!

CFast cards are only permitted to be inserted and removed in a voltage-free state!

4.1.5.6 Power and reset buttons



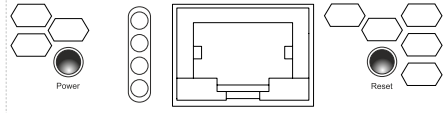







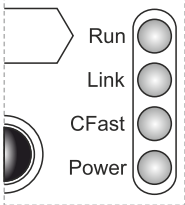

Both buttons can be pressed without any tools.

Description	
<p>Power button</p> <p>The power button offers full ATX power supply support and has various configurable functions.</p> <ul style="list-style-type: none"> • Short press: Switches the PC on or off or performs the action configured in the operating system when pressing the power button (shutdown, sleep, etc.). • Long press (approx. 4 s): The ATX power supply switches off the PC without shutting it down. <p>Pressing the power button does not reset the MTCX processor.</p>	
<p>Reset button</p> <p>Pressing the reset button triggers a hardware/PCI reset. The PC is restarted. During a reset, the MTCX processor is not reset.</p>	

Warning!

Switching off the power without shutting down or resetting the system can result in data loss!

4.1.5.7 LED status indicators

Assignment	LED	Color	Status	Explanation	LED status indicators ¹⁾	
	Power	Green	On	Power supply OK		
		Red	On	The system is in power saving mode (standby). ¹⁾		
		Red-Green	Blinking	Faulty or incomplete BIOS, MTCX or I/O FPGA update, power supply OK		
					Faulty or incomplete BIOS, MTCX or I/O FPGA update, power saving mode (standby)	
	Information: An update must be performed again.					
	CFast	Yellow	On	Indicates CFast access		
	Link	Yellow	On	Indicates an active SDL connection on the panel connector.		
			Blinking	An active SDL connection was interrupted due to power loss of the panel.		
	Information: Check the power supply or power connection of the connected panel.					
	Run	Green	Blinking	Automation Runtime is starting up. Controlled by Automation Runtime (ARemb and AR-win).		
			On	Application running. Controlled by Automation Runtime (ARemb and AR-win).		
			On	Application in SERVICE mode. Controlled by Automation Runtime (ARemb and AR-win).		
Blinking			A license violation has occurred.			

- 1) Two columns form 1 interval of 500 ms each.
- 2) S5: Soft-off
S4: Hibernate (suspend-to-disk)

4.1.5.8 Monitor/Panel interface

Automation PC system units have a monitor/panel interface. This can be configured with different monitor/panel options; a configuration without a monitor/panel option is also possible.

The following table lists the monitor/panel options that can be operated in the interface. For additional information, see section "Monitor/Panel options" on page 46.

Monitor/Panel interface	
Model number	Monitor/Panel option Short description
5ACCLI01.SDL0-000	SDL/DVI transmitter - For APC2100/APC2200
5ACCLI01.SDL3-000	SDL3 transmitter - For APC2100

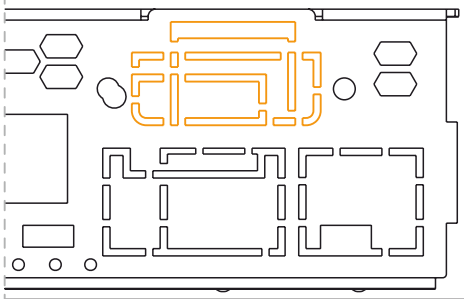

Information:

Monitor/Panel options can only be installed and replaced at the B&R factory.

4.1.5.9 IF option slot(IF1, IFx)

Automation PC system units have 1 slot for an interface option.

The following table lists the interface options that can be operated in the IF option slot.

IF option IF1, IFx slot	
Model number	Interface option - Short description
5ACCIF01.FPCC-000	Interface card - 2x CAN interfaces - 1x X2X Link interface - 1x POWERLINK interface - 512 kB nvSRAM - For APC2100/PPC2100 and APC2200/PPC2200
5ACCIF01.FPCS-000	Interface card - 1x RS485 interface - 1x CAN interface - 1x POWERLINK interface - 32 kB FRAM - For APC2100/PPC2100 and APC2200/PPC2200
5ACCIF01.FPLK-000	Interface card - 2x POWERLINK interfaces - 512 kB nvSRAM - For APC2100/PPC2100 and APC2200/PPC2200
5ACCIF01.FPLS-000	Interface card - 1x RS232 interface - 1x POWERLINK interface - 32 kB FRAM - For APC2100/PPC2100 and APC2200/PPC2200
5ACCIF01.FPLS-001	Interface card - 1x RS232 interface - 1x POWERLINK interface - 512 kB nvSRAM - For APC2100/PPC2100 and APC2200/PPC2200
5ACCIF01.FPSC-000	Interface card - 1x RS232 interface - 1x CAN interface - 1x POWERLINK interface - 32 kB FRAM - For APC2100/PPC2100 and APC2200/PPC2200
5ACCIF01.FPSC-001	Interface card - 1x RS232 interface - 1x CAN interface - 1x X2X Link interface - 1x POWERLINK interface - 512 kB nvSRAM - For APC2100/PPC2100 and APC2200/PPC2200
5ACCIF01.FSS0-000	Interface card - 2x RS422/RS485 interface - For APC2100/PPC2100 and APC2200/PPC2200
5ACCIF01.ICAN-000	Interface card - 1x CAN interface - For APC2100/PPC2100 and APC2200/PPC2200
5ACCIF01.IS00-000	Interface card - 1x RS232 interface - For APC2100/PPC2100/PPC2200

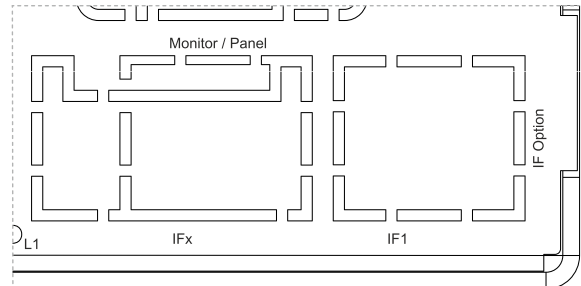

The diagram shows a top-down view of the IF option slot. It features a 'Monitor / Panel' at the top, an 'L1' component on the left, and two main slots labeled 'IFx' and 'IF1' at the bottom. An 'IF Option' slot is indicated on the right side of the diagram.

Information:

Interface options can only be installed and replaced at the B&R factory.

4.2 Individual components

4.2.1 System units

4.2.1.1 5APC2100.BYxx-000

4.2.1.1.1 General information

APC2100 system units consist of a CPU board, housing and mounting plate. All interfaces are included, an interface option and monitor/panel can be additionally installed. The main memory is permanently soldered to the CPU board and cannot be replaced or expanded.

- Intel Atom processors
- Intel Bay Trail platform
- DDR3 memory
- Intel HD graphics
- 1x CFast slot
- Insert for 1 monitor/panel option
- Slot for 1 interface option

4.2.1.1.2 Order data

Order number	Short description	Figure
System units		
5APC2100.BY01-000	APC2100 system unit - Intel Atom E3815 1.46 GHz - Single core - 1 GB SDRAM	
5APC2100.BY11-000	APC2100 system unit - Intel Atom E3825 1.33 GHz - Dual core - 1 GB SDRAM	
5APC2100.BY22-000	APC2100 system unit - Intel Atom E3826 1.46 GHz - Dual core - 2 GB SDRAM	
5APC2100.BY34-000	APC2100 system unit - Intel Atom E3827 1.75 GHz - Dual core - 4 GB SDRAM	
5APC2100.BY44-000	APC2100 system unit - Intel Atom E3845 1.91 GHz - Quad core - 4 GB SDRAM	
5APC2100.BY48-000	APC2100 system unit - Intel Atom E3845 1.91 GHz - Quad core - 8 GB SDRAM	
Required accessories		
CFast cards		
5CFAST.016G-00	CFast 16 GB SLC	
5CFAST.032G-00	CFast 32 GB SLC	
5CFAST.032G-10	CFast 32 GB MLC	
5CFAST.064G-10	CFast 64 GB MLC	
5CFAST.128G-10	CFast 128 GB MLC	
5CFAST.256G-10	CFast 256 GB MLC	
Optional accessories		
Interface options		
5ACCIF01.FPCC-000	Interface card - 2x CAN interfaces - 1x X2X Link interface - 1x POWERLINK interface - 512 kB nvSRAM - For APC2100/PPC2100/APC2200/PPC2200 - Only available with a new device	
5ACCIF01.FPCS-000	Interface card - 1x RS485 interface - 1x CAN interface - 1x POWERLINK interface - 32 kB FRAM - For APC2100/PPC2100/APC2200/PPC2200 - Only available with a new device	
5ACCIF01.FPLK-000	Interface card - 1x POWERLINK interface - Integrated 2-port hub - 512 kB nvSRAM - For APC2100/PPC2100/APC2200/PPC2200 - Only available with a new device	
5ACCIF01.FPLS-000	Interface card - 1x RS232 interface - 1x POWERLINK interface - 32 kB FRAM - For APC2100/PPC2100/APC2200/PPC2200 - Only available with a new device	
5ACCIF01.FPLS-001	Interface card - 1x RS232 interface - 1x POWERLINK interface - 512 kB nvSRAM - For APC2100/PPC2100/APC2200/PPC2200 - Only available with a new device	
5ACCIF01.FPSC-000	Interface card - 1x RS232 interface - 1x CAN interface - 1x POWERLINK interface - 32 kB FRAM - For APC2100/PPC2100/APC2200/PPC2200 - Only available with a new device	
5ACCIF01.FPSC-001	Interface card - 1x RS232 interface - 1x CAN interface - 1x X2X Link Interface - 1x POWERLINK interface - 512 kB nvSRAM - For APC2100/PPC2100/APC2200/PPC2200 - Only available with a new device	
5ACCIF01.FSS0-000	Interface card - 2x RS422/RS485 interface - For APC2100/PPC2100/APC2200/PPC2200 - Only available with a new device	
5ACCIF01.ICAN-000	Interface card - 1x CAN interface - For APC2100/PPC2100/APC2200/PPC2200 - Only available with a new device	
5ACCIF01.IS00-000	Interface card - 1x RS232 interface - For APC2100/PPC2100/APC2200/PPC2200 - Only available with a new device	
Monitor/Panel options		
5ACCLI01.SDL0-000	Monitor/Panel option - 1x SDL/DVI transmitter - For APC2100/APC2200 - Only available with a new device	
5ACCLI01.SDL3-000	Monitor/Panel option - 1x SDL3 transmitter - For APC2100 - Only available with a new device	

4.2.1.1.3 Technical data

Information:

The following specified characteristic data, features and limit values are only valid for these individual components and may differ from those of the complete system. The data specified for the complete system applies to the complete system in which an individual component is used.

Order number	5APC2100. BY01-000	5APC2100. BY11-000	5APC2100. BY22-000	5APC2100. BY34-000	5APC2100. BY44-000	5APC2100. BY48-000
General information						
LEDs	Power, CFast, Link, Run					
B&R ID code	0xE5C1	0xE5C2	0xE5C3	0xE5C4	0xE5C5	0xED0D
Cooling	Passive via housing					
Power button	Yes					
Reset button	Yes					
Buzzer	No					
Certifications						
CE	Yes					
UKCA	Yes					
UL	cULus E115267 Industrial control equipment					
HazLoc	cULus HazLoc E180196 Industrial control equipment for hazardous locations Class I, Division 2, Groups ABCD, T4					
DNV	-				Temperature: B (0 to 55°C) Humidity: B (up to 100%) Vibration: A (0.7 g) EMC: B (bridge and open deck)	
LR	-				ENV3	
KR	-				Yes	
ABS	-				Yes	
BV	-				EC31B Temperature: 5 - 55°C Vibration: 0.7 g EMC: Bridge and open deck	
Controller						
Bootloader	UEFI BIOS					
Processor						
Type	Intel Atom E3815	Intel Atom E3825	Intel Atom E3826	Intel Atom E3827	Intel Atom E3845	
Clock frequency	1460 MHz	1330 MHz	1460 MHz	1750 MHz	1910 MHz	
Number of cores	1	2			4	
Architecture	22 nm					
Thermal design power (TDP)	5 W	6 W	7 W	8 W	10 W	
L2 cache	512 kB	1 MB			2 MB	
Intel 64 architecture	Yes					
Intel Hyper-Threading Technology	No					
Intel vPro Technology	No					
Intel Virtualization Technology (VT-x)	Yes					
Intel Virtualization Technology for Directed I/O (VT-d)	No					
Enhanced Intel SpeedStep Technology	Yes					
Chipset	Intel Bay Trail					
Real-time clock						
Accuracy	At 25°C: Typ. 12 ppm (1 second) per day ¹⁾					
Retention time ²⁾	Typ. approx. 400 h Min. approx. 200 h					
Battery-backed	No					
Power failure logic						
Controller	MTCX ³⁾					
Buffer time	10 ms					
Memory						
Type	DDR3 SDRAM					
Memory size	1 GB		2 GB	4 GB		8 GB
Speed	DDR3L-1067			DDR3L-1333		
Memory interface width	Single channel					Dual channel
Removable	No					
Graphics						
Controller	Intel HD Graphics					
Max. dynamic graphics frequency	400 MHz	533 MHz	667 MHz	792 MHz		
Color depth	Max. 32-bit					
DirectX support	11					
OpenGL support	4.0					
Power management	ACPI 4.0					

Order number	5APC2100. BY01-000	5APC2100. BY11-000	5APC2100. BY22-000	5APC2100. BY34-000	5APC2100. BY44-000	5APC2100. BY48-000
Interfaces						
C/Fast slot						
Quantity	1					
Type	SATA II (SATA 3.0 Gbit/s)					
USB						
Quantity	2					
Type	1x USB 3.0 1x USB 2.0					
Variant	Type A					
Transfer rate	Low speed (1.5 Mbit/s), full speed (12 Mbit/s), high speed (480 Mbit/s) to SuperSpeed (5 Gbit/s) ⁴⁾					
Current-carrying capacity	Max. 1 A per connection					
Ethernet						
Quantity	2					
Variant	RJ45, shielded					
Transfer rate	10/100/1000 Mbit/s					
Max. baud rate	1 Gbit/s					
Slots						
Interface option ⁵⁾	1					
Monitor/Panel option ⁶⁾	1					
Support						
Software						
Automation Studio	Up to V4.12					
Electrical properties						
Nominal voltage	24 VDC ±25%, SELV ⁷⁾					
Nominal current	Max. 3 A					
Inrush current	Typ. 6 A, max. 10 A for < 300 µs					
Oversvoltage category per EN 61131-2	II					
Galvanic isolation	Yes					
Operating conditions						
Pollution degree per EN 61131-2	Pollution degree 2					
Degree of protection per EN 60529	IP20 ⁸⁾					
Ambient conditions						
Elevation						
Operation	Max. 3000 m (component-dependent) ⁹⁾					
Mechanical properties						
Dimensions ¹⁰⁾						
Width	40 mm					
Height	115 mm					
Depth	198 mm					
Weight	1170 g					

- 1) At max. specified ambient temperature: Typ. 58 ppm (5 seconds) - worst case 220 ppm (19 seconds).
- 2) To achieve the specified values for the self-discharge time, the product must be supplied with power for min. 8 hours.
- 3) Maintenance Controller Extended
- 4) The SuperSpeed transfer rate (5 Gbit/s) is only possible with USB 3.0.
- 5) The interface option cannot be replaced.
- 6) The monitor/panel option cannot be replaced.
- 7) IEC 61010-2-201 requirements must be observed.
- 8) Only if all interface covers are installed.
- 9) The maximum ambient temperature is typically derated 1°C per 1000 meters starting at 500 m above sea level.
- 10) All dimensions without mounting plate.

4.2.2 Monitor/Panel options

Information:

Monitor/Panel options can only be installed and replaced at the B&R factory.

4.2.2.1 5ACCLI01.SDL0-000

4.2.2.1.1 General information

Monitor/Panel option 5ACCLI01.SDL0-000 is equipped with an interface to connect panels via SDL or DVI.

- SDL/DVI interface
- Compatible with APC2100 and APC2200

4.2.2.1.2 Order data

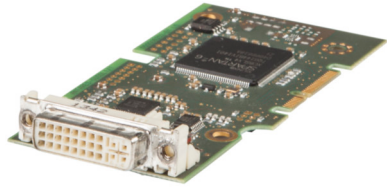
Order number	Short description	Figure
5ACCLI01.SDL0-000	Monitor/Panel option - 1x SDL/DVI transmitter - For APC2100/ APC2200 - Only available with a new device	

4.2.2.1.3 Technical data

Information:

The following specified characteristic data, features and limit values are only valid for this accessory and may differ from those of the complete system. The data specified for the complete system applies to the complete system in which an accessory is used.

Order number	5ACCLI01.SDL0-000
General information	
B&R ID code	0xE6B6
Certifications	
CE	Yes
UKCA	Yes
UL	cULus E115267 Industrial control equipment
HazLoc	cULus HazLoc E180196 Industrial control equipment for hazardous locations Class I, Division 2, Groups ABCD, T4
DNV	Temperature: B (0 to 55°C) Humidity: B (up to 100%) Vibration: A (0.7 g) EMC: B (bridge and open deck)
LR	ENV3
KR	Yes
ABS	Yes
BV	EC31B Temperature: 5 - 55°C Vibration: 0.7 g EMC: Bridge and open deck
Interfaces	
Panel/Monitor interface ¹⁾	
Variant	DVI-I
Type	SDL/DVI/RGB (SDL/DVI/RGB)
Electrical properties	
Power consumption	1 W
Ambient conditions	
Temperature	
Operation	-20 to 60°C ²⁾
Storage	-20 to 60°C
Transport	-20 to 60°C

Order number	5ACCLI01.SDL0-000
Relative humidity	
Operation	5 to 90%, non-condensing
Storage	5 to 95%, non-condensing
Transport	5 to 95%, non-condensing
Mechanical properties	
Weight	20 g

- 1) The APC2200 does not have an RGB interface, DVI-D variant.
- 2) For detailed information, see the temperature tables in the user's manual.
DVI and SDL operation is possible down to a minimum of -20°C; RGB operation is only possible down to a minimum of 0°C.

4.2.2.1.3.1 SDL/DVI interface

The interface is designed as a DVI-I connector (female) and can be operated with DVI-D or SDL transmission technology.

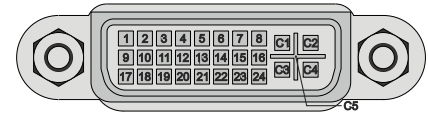

Pin	Pinout	Description	Pin	Pinout	Description
1	TMDS data 2-	DVI lane 2 (negative)	16	HPD	Hot plug detection
2	TMDS data 2+	DVI lane 2 (positive)	17	TMDS data 0-	DVI lane 0 (negative)
3	TMDS data 2/4 SHIELD	Shield for data pairs 2 and 4	18	TMDS data 0+	DVI lane 0 (positive)
4	SDL-	SDL lane (negative)	19	TMDS data 0/XUSB1 SHIELD	Shield of data pair 0 and USB1
5	SDL+	SDL lane (positive)	20	XUSB1-	USB lane 1 (negative)
6	DDC clock	DDC-based control signal (clock)	21	XUSB1+	USB lane 1 (positive)
7	DDC data	DDC-based control signal (data)	22	TMDS clock shield	Shield of clock pair
8	ANALOG VERT SYNC	Analog vertical synchronization	23	TMDS clock+	DVI clock (positive)
9	TMDS data 1-	DVI lane 1 (negative)	24	TMDS clock -	DVI clock (negative)
10	TMDS data 1+	DVI lane 1 (positive)	C1	ANALOG RED	Analog red
11	TMDS data 1/XUSB0 SHIELD	Shield of data pair 1 and USB0	C2	ANALOG GREEN	Analog green
12	XUSB0-	USB lane 0 (negative)	C3	ANALOG BLUE	Analog blue
13	XUSB0+	USB lane 0 (positive)	C4	ANALOG HORZ SYNC	Analog horizontal synchronization
14	+5 V power ¹⁾	+5 V power supply	C5	ANALOG GND	Analog ground (return for R, G and B signals)
15	Ground (return for +5 V, HSync and VSync)	Ground	-	-	-

- 1) Protected internally by a multifuse.

Information:

Hot plugging output devices on the interface for service purposes is supported by the hardware and graphic drivers of approved operating systems. Recalibration may be required for touch screen devices.

A maximum of 100 mating cycles are specified for this interface.

It is important to note the following information about the transfer rate:

- In SDL operation without USB type A/B cable, the USB transfer rate is limited to USB 1.1.
- A USB transfer rate of USB 2.0 is possible in DVI or SDL operation with a USB type A/B cable.

Cable lengths and resolutions for SDL transfer

The following table shows the relationship between segment length and maximum resolution depending on the SDL cable:

SDL cable Segment length [m]	Resolution								
	VGA 640 x 480	WVGA 800 x 480	SVGA 800 x 600	XGA 1024 x 768	HD 1366 x 768	WXGA 1200 x 800	SXGA 1280 x 1024	UXGA 1600 x 1200	FHD 1920 x 1080
0.8	5CASDL.0008-00	5CASDL.0008-00	5CASDL.0008-00	5CASDL.0008-00	5CASDL.0008-00	5CASDL.0008-00	5CASDL.0008-00	5CASDL.0008-00	5CASDL.0008-00
1.8	5CASDL.0018-00 5CASDL.0018-01 5CASDL.0018-03	5CASDL.0018-00 5CASDL.0018-01 5CASDL.0018-03	5CASDL.0018-00 5CASDL.0018-01 5CASDL.0018-03	5CASDL.0018-00 5CASDL.0018-01 5CASDL.0018-03	5CASDL.0018-00 5CASDL.0018-01 5CASDL.0018-03	5CASDL.0018-00 5CASDL.0018-01 5CASDL.0018-03	5CASDL.0018-00 5CASDL.0018-01 5CASDL.0018-03	5CASDL.0018-00 5CASDL.0018-01 5CASDL.0018-03	5CASDL.0018-00 5CASDL.0018-01 5CASDL.0018-03
5	5CASDL.0050-00 5CASDL.0050-01 5CASDL.0050-03	5CASDL.0050-00 5CASDL.0050-01 5CASDL.0050-03	5CASDL.0050-00 5CASDL.0050-01 5CASDL.0050-03	5CASDL.0050-00 5CASDL.0050-01 5CASDL.0050-03	5CASDL.0050-00 5CASDL.0050-01 5CASDL.0050-03	5CASDL.0050-00 5CASDL.0050-01 5CASDL.0050-03	5CASDL.0050-00 5CASDL.0050-01 5CASDL.0050-03	5CASDL.0050-00 5CASDL.0050-01 5CASDL.0050-03	5CASDL.0050-00 5CASDL.0050-01 5CASDL.0050-03
6	5CASDL.0060-00	5CASDL.0060-00	5CASDL.0060-00	5CASDL.0060-00	5CASDL.0060-00	5CASDL.0060-00	5CASDL.0060-00	5CASDL.0060-00	5CASDL.0060-00
10	5CASDL.0100-00 5CASDL.0100-01 5CASDL.0100-03	5CASDL.0100-00 5CASDL.0100-01 5CASDL.0100-03	5CASDL.0100-00 5CASDL.0100-01 5CASDL.0100-03	5CASDL.0100-00 5CASDL.0100-01 5CASDL.0100-03	5CASDL.0100-00 5CASDL.0100-01 5CASDL.0100-03	5CASDL.0100-00 5CASDL.0100-01 5CASDL.0100-03	5CASDL.0100-00 5CASDL.0100-01 5CASDL.0100-03	5CASDL.0100-00 5CASDL.0100-01 5CASDL.0100-03	5CASDL.0100-00 5CASDL.0100-01 5CASDL.0100-03
15	5CASDL.0150-00 5CASDL.0150-01 5CASDL.0150-03	5CASDL.0150-00 5CASDL.0150-01 5CASDL.0150-03	5CASDL.0150-00 5CASDL.0150-01 5CASDL.0150-03	5CASDL.0150-00 5CASDL.0150-01 5CASDL.0150-03	5CASDL.0150-00 5CASDL.0150-01 5CASDL.0150-03	5CASDL.0150-00 5CASDL.0150-01 5CASDL.0150-03	5CASDL.0150-00 5CASDL.0150-01 5CASDL.0150-03	- - -	- - 5CASDL.0150-03
20	5CASDL.0200-00 5CASDL.0200-03	5CASDL.0200-00 5CASDL.0200-03	5CASDL.0200-00 5CASDL.0200-03	5CASDL.0200-00 5CASDL.0200-03	5CASDL.0200-00 5CASDL.0200-03	5CASDL.0200-00 5CASDL.0200-03	5CASDL.0200-00 5CASDL.0200-03	- -	- 5CASDL.0200-03
25	5CASDL.0250-00 5CASDL.0250-03	5CASDL.0250-00 5CASDL.0250-03	5CASDL.0250-00 5CASDL.0250-03	5CASDL.0250-00 5CASDL.0250-03	5CASDL.0250-00 5CASDL.0250-03	- -	- -	- -	- -
30	5CASDL.0300-00 5CASDL.0300-03	5CASDL.0300-00 5CASDL.0300-03	5CASDL.0300-00 5CASDL.0300-03	- -	- -	- -	- -	- -	- 5CASDL.0300-13
40	5CASDL.0400-13	5CASDL.0400-13	5CASDL.0400-13	5CASDL.0400-13	5CASDL.0400-13	5CASDL.0400-13	5CASDL.0400-13	-	5CASDL.0400-13

Cable lengths and resolutions for DVI transfer

The following table shows the relationship between segment length and maximum resolution depending on the DVI cable:

DVI cable Segment length [m]	Resolution									
	VGA 640 x 480	WVGA 800 x 480	SVGA 800 x 600	XGA 1024 x 768	HD 1366 x 768	WXGA 1280 x 800	SXGA 1280 x 1024	UXGA 1600 x 1200	FHD 1920 x 1080	WUXGA 1920 x 1200
1.8	5CADVI.0018-00	5CADVI.0018-00	5CADVI.0018-00	5CADVI.0018-00	5CADVI.0018-00	5CADVI.0018-00	5CADVI.0018-00	5CADVI.0018-00	5CADVI.0018-00	5CADVI.0018-00
5	5CADVI.0050-00	5CADVI.0050-00	5CADVI.0050-00	5CADVI.0050-00	5CADVI.0050-00	5CADVI.0050-00	5CADVI.0050-00	5CADVI.0050-00	5CADVI.0050-00	5CADVI.0050-00

The maximum cable length for DVI transfer is limited to 5 m due to the USB specification.

4.2.2.2 5ACCLI01.SDL3-000

4.2.2.2.1 General information

The 5ACCLI01.SDL3-000 monitor/panel option is equipped with an SDL3 interface.

- SDL3 interface
- Compatible with the APC2100

4.2.2.2.2 Order data

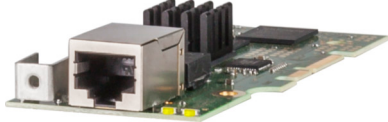
Order number	Short description	Figure
5ACCLI01.SDL3-000	Monitor/Panel options Monitor/Panel option - 1x SDL3 transmitter - For APC2100 - Only available with a new device	

4.2.2.2.3 Technical data

Information:

The following specified characteristic data, features and limit values are only valid for this accessory and may differ from those of the complete system. The data specified for the complete system applies to the complete system in which an accessory is used.

Order number	5ACCLI01.SDL3-000
General information	
B&R ID code	0xE6C1
Certifications	
CE	Yes
UKCA	Yes
UL	cULus E115267 Industrial control equipment
HazLoc	cULus HazLoc E180196 Industrial control equipment for hazardous locations Class I, Division 2, Groups ABCD, T4
Interfaces	
SDL3 Out	
Variant	RJ45, shielded
Type	SDL3
Electrical properties	
Power consumption	4 W
Ambient conditions	
Temperature	
Operation	0 to 50°C ¹⁾
Storage	-20 to 60°C
Transport	-20 to 60°C
Relative humidity	
Operation	5 to 90%, non-condensing
Storage	5 to 95%, non-condensing
Transport	5 to 95%, non-condensing
Mechanical properties	
Weight	20 g

1) For detailed information, see the temperature tables in the user's manual.

4.2.2.2.3.1 SDL3 interface

The SDL3 Out interface is a female RJ45 connector and operated with SDL3 transmission technology.

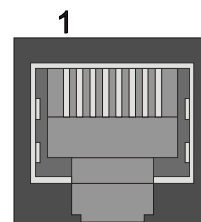

Information:

Hot plugging output devices on the interface for service purposes is supported by the hardware and graphic drivers of approved operating systems. Recalibration may be required for touch screen devices.

A maximum of 500 mating cycles are specified for this interface.

4.2.2.2.3.2 Cable lengths and resolutions for SDL3 transfer

The maximum cable length for SDL3 transfers is 100 m with a B&R SDL3/SDL4 cable (regardless of the panel resolution).

4.2.2.2.3.3 SDL3 LEDs

SDL3 - LED status indicators			
LED	Color	Status	Explanation
Link (1)	Yellow	On	Indicates an active SDL3 connection
		Off	No active SDL3 connection
Status (2)	Yellow	On	SDL3 connection established and OK
		Blinking	No active SDL3 connection

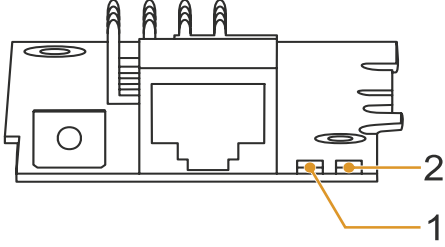

The diagram shows a side view of the SDL3 interface. Two LEDs are highlighted with orange lines and labeled '1' and '2'. LED 1 is a small circular LED, and LED 2 is a larger rectangular LED. The interface also features a DVI connector and a USB connector.

4.2.2.2.3.4 General limitations/characteristics

- USB 2.0 transfer is limited to 30 Mbit/s with SDL3.
- A display is always emulated by the SDL3 transmitter using EDID data and hot plug detection, so DVI-compatible operation is possible. For this reason, the following behavior may occur during operation with multiple displays. In the operating system, a connected panel is reported by the video driver even in the following situations:
 - No SDL3/SDL4 cable is connected.
 - There is no connection established yet between the SDL3 link module and SDL3 transmitter.

This behavior can be avoided by appropriate configuration in BIOS or via the graphics driver.

4.2.3 Interface options

Information:

It is important to note that not every interface option can be connected to interface slot IF1 and IFx. For additional information, see section "IF option slot(IF1, IFx)" on page 41.

Information:

Interface options can only be installed and replaced at the B&R factory.

4.2.3.1 5ACCIF01.FPCC-000

4.2.3.1.1 General information

Interface option 5ACCIF01.FPCC-000 is equipped with a POWERLINK interface, 2 CAN bus master interfaces and an X2X Link master interface. In addition, 512 kB nvSRAM is installed.

- 1x POWERLINK interface managing or controlled node
- 2x CAN bus master interfaces
- 1x X2X Link master interface
- 512 kB nvSRAM
- Compatible with APC2100/PPC2100 and APC2200/PPC2200

This interface option can only be operated with Automation Runtime.

4.2.3.1.2 Order data

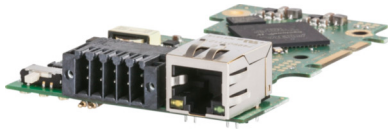
Order number	Short description	Figure
	Interface options	
5ACCIF01.FPCC-000	Interface card - 2x CAN interfaces - 1x X2X Link interface - 1x POWERLINK interface - 512 kB nvSRAM - For APC2100/PPC2100/APC2200/PPC2200 - Only available with a new device	
	Optional accessories	
	Terminal blocks	
0TB1210.3100	Connector 300 VDC - 10-pin female - Cage clamp terminal block - Protected against vibration by the screw flange	

4.2.3.1.3 Technical data

Information:

The following specified characteristic data, features and limit values are only valid for this accessory and may differ from those of the complete system. The data specified for the complete system applies to the complete system in which an accessory is used.

Order number	5ACCIF01.FPCC-000
General information	
LEDs	L1, L2, L3
B&R ID code	0xE9BD
Certifications	
CE	Yes
UKCA	Yes
UL	cULus E115267 Industrial control equipment
HazLoc	cULus HazLoc E180196 Industrial control equipment for hazardous locations Class I, Division 2, Groups ABCD, T4
DNV	Temperature: B (0 to 55°C) Humidity: B (up to 100%) Vibration: A (0.7 g) EMC: B (bridge and open deck)
LR	ENV3
KR	Yes
ABS	Yes
BV	EC31B Temperature: 5 - 55°C Vibration: 0.7 g EMC: Bridge and open deck

Technical data

Order number	5ACCIF01.FPCC-000
Controller	
nvSRAM	
Size	512 kB
Data retention	20 years
Read/Write endurance	Min. 1,000,000
Battery-backed	No
Remanent variables in power failure mode	256 kB (for e.g. Automation Runtime, see Automation Help)
Interfaces	
POWERLINK	
Quantity	1
Type	Type 4 ¹⁾
Variant	RJ45, shielded
Transfer rate	100 Mbit/s
Transfer	100BASE-TX
Line length	Max. 100 m between two stations (segment length)
CAN	
Quantity	2
Variant	10-pin, male ²⁾
Transfer rate	Max. 1 Mbit/s
Terminating resistor	
Type	Can be switched on and off with slide switch ³⁾
Default setting	Each off
X2X	
Type	X2X Link master
Quantity	1
Variant	10-pin, male, galvanically isolated
Electrical properties	
Power consumption	2 W
Operating conditions	
Pollution degree per EN 61131-2	Pollution degree 2
Ambient conditions	
Temperature	
Operation	-20 to 55°C
Storage	-20 to 60°C
Transport	-20 to 60°C
Relative humidity	
Operation	5 to 90%, non-condensing
Storage	5 to 95%, non-condensing
Transport	5 to 95%, non-condensing
Mechanical properties	
Weight	25 g

- 1) For additional information, see Automation Help (**Communication / POWERLINK / General information / Hardware - IF / LS**).
- 2) CAN1: Galvanically isolated.
CAN2: Not galvanically isolated.
- 3) The terminating resistor can only be switched on/off for the CAN1 interface.

4.2.3.1.3.1 POWERLINK interface - Pinout

The POWERLINK interface on the system unit is referred to as "IF1".

POWERLINK - IF1 ¹⁾²⁾		
Variant	RJ45, female	
Wiring	S/STP (Cat 5e)	
Cable length	Max. 100 m (min. Cat 5e)	
LED status indicator (b)	On	Off
Green	see "LED "S/E" (status/error LED)" on page 182	
LED "Link" (a)	On	Active
Yellow	Link (a connection to a POWERLINK network exists)	Blinking (data being transferred)

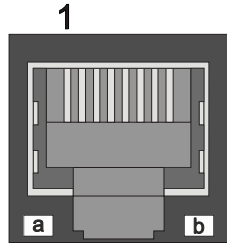

- 1) The interfaces, etc. available on the device or module have been numbered for the purpose of clear differentiation. This numbering may deviate from the numbering used by the respective operating system, however.
- 2) In Automation Studio / Automation Runtime, this interface is referred to as IF1.

4.2.3.1.3.2 CAN bus 1 interface - Pinout

The CAN bus 1 interface on the system unit is referred to as "IFx".

A terminating resistor can be switched on or off for the CAN bus 1 interface. LED status indicator "L1" indicates whether the terminating resistor is switched on or off.

CAN bus 1 - IFx ¹⁾²⁾	
Variant	10-pin, male
Galvanic isolation	Yes
Transfer rate	Max. 1 Mbit/s
Bus length	Max. 1000 m
Pin	Pinout
1	-
2	Shield
3	-
4	-
5	CAN H
6	CAN L
7	CAN GND
8	-
9	-
10	-

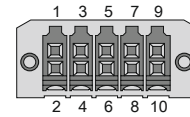

- 1) The interfaces, etc. available on the device or module have been numbered for the purpose of clear differentiation. This numbering may deviate from the numbering used by the respective operating system, however.
- 2) This interface can only be used in Automation Runtime and is displayed as IF3 in Automation Studio / Automation Runtime. It is not a "PC interface" and therefore not displayed in BIOS.

CAN driver settings

The baud rate can be set either with "predefined values" or via the "bit timing register". For additional information, see Automation Help.

Bit timing register 0	Bit timing register 1	Baud rate
00h	14h	1000 kbit/s
80h or 00h	1Ch	500 kbit/s
81h or 01h	1Ch	250 kbit/s
83h or 03h	1Ch	125 kbit/s
84h or 04h	1Ch	100 kbit/s
89h or 09h	1Ch	50 kbit/s

Cable data

For more detailed information about the transfer rate, bus length or cable requirements for the respective interfaces/buses, see "Cable data" on page 180.

Terminating resistor

A terminating resistor is integrated on the interface option. A switch is used to switch the terminating resistor for the CAN bus 1 interface on and off. The terminating resistor cannot be switched on and off for the CAN bus 2 interface. LED status indicator "L1" indicates whether the terminating resistor of the CAN bus 1 interface is switched on or off.

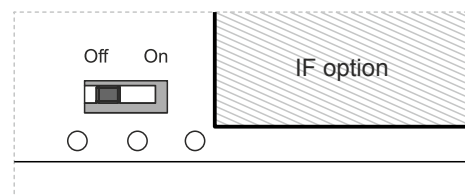

- ON: Switched on
- OFF (default): Switched off

4.2.3.1.3.3 CAN bus 2 interface - Pinout

The CAN bus 2 interface on the system unit is referred to as "IFx".

The terminating resistor cannot be switched on and off for the CAN bus 2 interface. A terminating resistor must therefore be taken into account during wiring.

CAN bus 2 - IFx ¹⁾²⁾	
Variant	10-pin, male
Galvanic isolation	No
Transfer rate	Max. 1 Mbit/s
Bus length	Max. 1000 m
Pin	Pinout
1	-
2	Shield
3	-
4	-
5	-
6	-
7	-
8	CAN GND
9	CAN L
10	CAN H

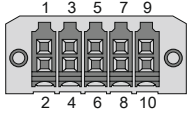

- 1) The interfaces, etc. available on the device or module have been numbered for the purpose of clear differentiation. This numbering may deviate from the numbering used by the respective operating system, however.
- 2) This interface can only be used in Automation Runtime and is displayed as IF4 in Automation Studio / Automation Runtime. It is not a "PC interface" and therefore not displayed in BIOS.

CAN driver settings

The baud rate can be set either with "predefined values" or via the "bit timing register". For additional information, see Automation Help.

Bit timing register 0	Bit timing register 1	Baud rate
00h	14h	1000 kbit/s
80h or 00h	1Ch	500 kbit/s
81h or 01h	1Ch	250 kbit/s
83h or 03h	1Ch	125 kbit/s
84h or 04h	1Ch	100 kbit/s
89h or 09h	1Ch	50 kbit/s

Cable data

For more detailed information about the transfer rate, bus length or cable requirements for the respective interfaces/buses, see "Cable data" on page 180.

4.2.3.1.3.4 X2X Link master interface - Pinout

The X2X Link master interface on the system unit is referred to as "IFx".

X2X Link master - IFx ¹⁾²⁾	
Variant	10-pin, male
Galvanic isolation	Yes
Pin	Pinout
1	X2X
2	Shield
3	X2X _I
4	X2X _L
5	-
6	-
7	-
8	-
9	-
10	-

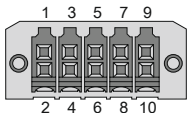

- 1) The interfaces, etc. available on the device or module have been numbered for the purpose of clear differentiation. This numbering may deviate from the numbering used by the respective operating system, however.
- 2) This interface can only be used in Automation Runtime and is displayed as IF2 in Automation Studio / Automation Runtime. It is not a "PC interface" and therefore not displayed in BIOS.

4.2.3.1.3.5 LED status indicators L1, L2, L3

The LEDs of the interface option are located near the ETH1 interface.

LED status indicators			
LED	Color	Status	Explanation
L1	Yellow	On	The CAN bus 1 terminating resistor is switched on.
		Off	The CAN bus 1 terminating resistor is switched off.
L2	Green	On	POWERLINK link LED A connection to a POWERLINK network exists.
		Blinking	POWERLINK link LED Data is being transferred.
L3	Green-Red	On	POWERLINK status/error LED See "LED "S/E" (status/error LED)" on page 182.
		Off	POWERLINK status/error LED See "LED "S/E" (status/error LED)" on page 182.

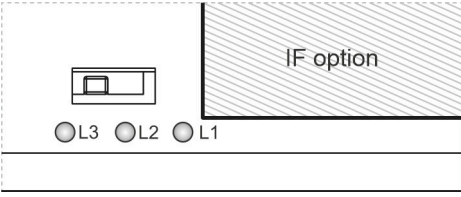

The diagram shows a 10-pin female connector with three LEDs labeled L3, L2, and L1. A shaded area labeled 'IF option' is shown to the right of the connector.

POWERLINK commissioning and operation

For a description of the operating modes, status and node numbers of the POWERLINK interface(s), see "LED "S/E" (status/error LED)" on page 182.

4.2.3.1.4 Shielding

For the interfaces on the 10-pin female connector, the shield of the interfaces can be connected to pin *Shield* (pin 2) of the female connector.

In addition, there is a functional ground connection on the interface cover of the system unit and a screw point for cable shields that can also be used for the shielded cables.

4.2.3.1.5 Driver support and firmware update

The driver is part of the Automation Runtime and the firmware is part of Automation Studio. The module is automatically brought up to this level.

To update the firmware contained in Automation Studio, a hardware upgrade must be performed (see **Project management / Workspace / Upgrades** in Automation Help).

4.2.3.2 5ACCIF01.FPCS-000

4.2.3.2.1 General information

Interface option 5ACCIF01.FPCS-000 is equipped with a POWERLINK, RS485 and CAN bus master interface. In addition, 32 kB FRAM is installed.

- 1x POWERLINK interface managing or controlled node
- 1x CAN bus master interface
- 1x RS485 interface
- 32 kB FRAM
- Compatible with APC2100/PPC2100 and APC2200/PPC2200

This interface option can only be operated with Automation Runtime.

4.2.3.2.2 Order data

Order number	Short description	Figure
5ACCIF01.FPCS-000	Interface card - 1x RS485 interface - 1x CAN interface - 1x POWERLINK interface - 32 kB FRAM - For APC2100/PPC2100/ APC2200/PPC2200 - Only available with a new device	
	Optional accessories	
	Terminal blocks	
0TB1210.3100	Connector 300 VDC - 10-pin female - Cage clamp terminal block - Protected against vibration by the screw flange	

4.2.3.2.3 Technical data

Information:

The following specified characteristic data, features and limit values are only valid for this accessory and may differ from those of the complete system. The data specified for the complete system applies to the complete system in which an accessory is used.

Order number	5ACCIF01.FPCS-000
General information	
LEDs	L1, L2, L3
B&R ID code	0xED7C
Certifications	
CE	Yes
UKCA	Yes
UL	cULus E115267 Industrial control equipment
HazLoc	cULus HazLoc E180196 Industrial control equipment for hazardous locations
DNV	Class I, Division 2, Groups ABCD, T4 Temperature: B (0 to 55°C) Humidity: B (up to 100%) Vibration: A (0.7 g) EMC: B (bridge and open deck)
LR	ENV3
ABS	Yes
BV	EC31B Temperature: 5 - 55°C Vibration: 0.7 g EMC: Bridge and open deck
Controller	
FRAM	
Size	32 kB
Data retention	10 years
Read/Write endurance	Min. 10 ¹² times/byte
Remanent variables in power failure mode	32 kB (for e.g. Automation Runtime, see Automation Help)
Interfaces	
COM	
Quantity	1
Type	RS485, not galvanically isolated
Variant	10-pin, male
UART	16550-compatible, 16-byte FIFO buffer
Max. baud rate	115 kbit/s

Order number	5ACCIF01.FPCS-000
POWERLINK	
Quantity	1
Type	Type 4 ¹⁾
Variant	RJ45, shielded
Transfer rate	100 Mbit/s
Transfer	100BASE-TX
Line length	Max. 100 m between two stations (segment length)
CAN	
Quantity	1
Variant	10-pin, male, not galvanically isolated
Transfer rate	Max. 1 Mbit/s
Terminating resistor	
Type	Can be switched on and off with slide switch
Default setting	Off
Electrical properties	
Power consumption	1.75 W
Operating conditions	
Pollution degree per EN 61131-2	Pollution degree 2
Ambient conditions	
Temperature	
Operation	-20 to 55°C
Storage	-20 to 60°C
Transport	-20 to 60°C
Relative humidity	
Operation	5 to 90%, non-condensing
Storage	5 to 95%, non-condensing
Transport	5 to 95%, non-condensing
Mechanical properties	
Weight	25 g

1) For additional information, see Automation Help (**Communication / POWERLINK / General information / Hardware - IF / LS**).

4.2.3.2.3.1 POWERLINK interface - Pinout

The POWERLINK interface on the system unit is referred to as "IF1".

POWERLINK - IF1 ¹⁾²⁾		
Variant	RJ45, female	
Wiring	S/STP (Cat 5e)	
Cable length	Max. 100 m (min. Cat 5e)	
LED status indicator (b)	On	Off
Green	See status/error LED.	
LED "Link" (a)	On	Active
Yellow	Link (a connection to a POWERLINK network exists)	Blinking (data being transferred)

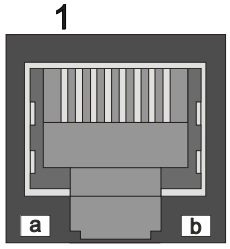

- 1) The interfaces, etc. available on the device or module have been numbered for the purpose of clear differentiation. This numbering may deviate from the numbering used by the respective operating system, however.
- 2) In Automation Studio / Automation Runtime, this interface is referred to as IF1.

4.2.3.2.3.2 Serial interface COM - Pinout

Serial interface COM on the system unit is referred to as "IFx".

Serial interface COM - IFx ¹⁾²⁾	
Variant	RS485
Type	10-pin, male
Galvanic isolation	RS485
UART	No
Transfer rate	16550-compatible, 16-byte FIFO buffer
Bus length	Max. 115 kbit/s
	Max. 1200 m
Pin	Pinout
1	-
2	Shield
3	-
4	-
5	-
6	-
7	-
8	COM GND
9	DATA\
10	DATA

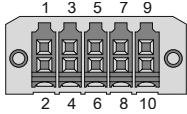

- 1) The interfaces, etc. available on the device or module have been numbered for the purpose of clear differentiation. This numbering may deviate from the numbering used by the respective operating system, however.
- 2) This interface can only be used in Automation Runtime and is displayed as IF7 in Automation Studio / Automation Runtime. It is not a "PC interface" and therefore not displayed in BIOS.

The RTS line must be switched by the driver for each transmission or reception; switching back does not take place automatically.

With long cable lengths, the voltage drop can result in greater potential differences between the bus devices, which can hinder communication. This can be improved by running the ground wire with the others.

Cable data

For more detailed information about the transfer rate, bus length or cable requirements for the respective interfaces/buses, see ["Cable data" on page 180](#).

4.2.3.2.3.3 CAN bus interface - Pinout

The CAN bus interface on the system unit is referred to as "IFx".

CAN bus - IFx ¹⁾²⁾	
Variant	10-pin, male
Galvanic isolation	No
Transfer rate	Max. 1 Mbit/s
Bus length	Max. 1000 m
Pin	Pinout
1	-
2	Shield
3	-
4	-
5	CAN H
6	CAN L
7	CAN GND
8	-
9	-
10	-

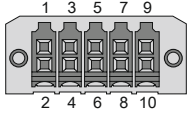

- 1) The interfaces, etc. available on the device or module have been numbered for the purpose of clear differentiation. This numbering may deviate from the numbering used by the respective operating system, however.
- 2) This interface can only be used in Automation Runtime and is displayed as IF3 in Automation Studio / Automation Runtime. It is not a "PC interface" and therefore not displayed in BIOS.

CAN driver settings

The baud rate can be set either with "predefined values" or via the "bit timing register".

For additional information, see Automation Help.

Bit timing register 0	Bit timing register 1	Baud rate
00h	14h	1000 kbit/s
80h or 00h	1Ch	500 kbit/s
81h or 01h	1Ch	250 kbit/s
83h or 03h	1Ch	125 kbit/s
84h or 04h	1Ch	100 kbit/s
89h or 09h	1Ch	50 kbit/s

Cable data

For more detailed information about the transfer rate, bus length or cable requirements for the respective interfaces/buses, see "Cable data" on page 180.

Terminating resistor

A terminating resistor is integrated on the interface option. It is switched on or off for the CAN bus interface with a switch. LED status indicator L1 indicates the current state:

- ON: Activated
- OFF (default): Switched off

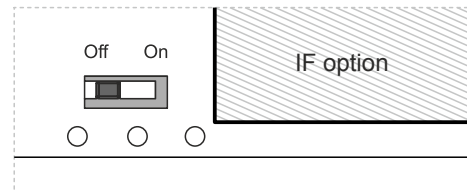

4.2.3.2.3.4 LED status indicators

The LEDs of the interface option are located near the ETH1 interface.

LED status indicators			
LED	Color	Status	Explanation
L1	Yellow	On	The CAN bus terminating resistor is switched on.
		Off	The CAN bus terminating resistor is switched off.
L2	Green	On	POWERLINK link LED A connection to a POWERLINK network exists.
		Blinking	POWERLINK link LED Data is being transferred.
L3	Green-Red	On	POWERLINK status/error LED See "LED "S/E" (status/error LED)" on page 182.
		Off	POWERLINK status/error LED See "LED "S/E" (status/error LED)" on page 182.

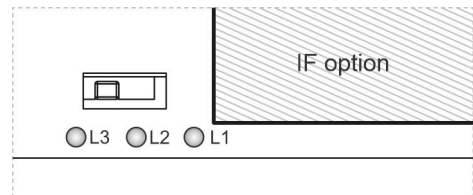

POWERLINK commissioning and operation

For a description of the operating modes, status and node numbers of the POWERLINK interface(s), see "LED "S/E" (status/error LED)" on page 182.

4.2.3.2.4 Shielding

For the interfaces on the 10-pin female connector, the shield of the interfaces can be connected to pin *Shield* (pin 2) of the female connector.

In addition, there is a functional ground connection on the interface cover of the system unit and a screw point for cable shields that can also be used for the shielded cables.

4.2.3.2.5 Driver support and firmware update

The driver is part of the Automation Runtime and the firmware is part of Automation Studio. The module is automatically brought up to this level.

To update the firmware contained in Automation Studio, a hardware upgrade must be performed (see **Project management / Workspace / Upgrades** in Automation Help).

4.2.3.3 5ACCIF01.FPLK-000

4.2.3.3.1 General information

Interface option 5ACCIF01.FPLK-000 is equipped with 2 female RJ45 connectors; both connectors are connected to an integrated POWERLINK hub. In addition, 512 kB nvSRAM is installed.

With the integrated 2-port hub, a simple tree structure, daisy chain wiring or optional ring redundancy can be easily implemented without additional effort.

With poll-response chaining (PRC), the IF option offers a solution for the highest demands on response time and the shortest cycle times. Especially for central control tasks, poll-response chaining in combination with the B&R control system provides ideal performance.

- 1x POWERLINK interface for real-time communication
- 512 kB nvSRAM
- Integrated hub for economical wiring
- Configurable ring redundancy
- Poll-response chaining
- Compatible with APC2100/PPC2100 and APC2200/PPC2200

This interface option can only be operated with Automation Runtime.

Information:

Ring redundancy in combination with poll-response chaining is not possible at the same time with this IF option.

4.2.3.3.2 Order data

Order number	Short description	Figure
	Interface options	
5ACCIF01.FPLK-000	Interface card - 1x POWERLINK interface - Integrated 2-port hub - 512 kB nvSRAM - For APC2100/PPC2100/APC2200/PPC2200 - Only available with a new device	

4.2.3.3.3 Technical data

Information:

The following specified characteristic data, features and limit values are only valid for this accessory and may differ from those of the complete system. The data specified for the complete system applies to the complete system in which an accessory is used.

Order number	5ACCIF01.FPLK-000
General information	
LEDs	L1, L2, L3
B&R ID code	0xE9BA
Certifications	
CE	Yes
UKCA	Yes
UL	cULus E115267 Industrial control equipment
HazLoc	cULus HazLoc E180196 Industrial control equipment for hazardous locations Class I, Division 2, Groups ABCD, T4
Controller	
nvSRAM	
Size	512 kB
Data retention	20 years
Read/Write endurance	Min. 1,000,000
Battery-backed	No
Remanent variables in power failure mode	256 kB (for e.g. Automation Runtime, see Automation Help)

Order number	5ACCIF01.FPLK-000
Interfaces	
POWERLINK	
Quantity	1 (integrated 2-port hub)
Type	Type 4, redundant ¹⁾
Variant	RJ45, shielded
Transfer rate	100 Mbit/s
Transfer	100BASE-TX
Line length	Max. 100 m between two stations (segment length)
Electrical properties	
Power consumption	1.75 W
Operating conditions	
Pollution degree per EN 61131-2	Pollution degree 2
Ambient conditions	
Temperature	
Operation	-20 to 55°C
Storage	-20 to 60°C
Transport	-20 to 60°C
Relative humidity	
Operation	5 to 90%, non-condensing
Storage	5 to 95%, non-condensing
Transport	5 to 95%, non-condensing
Mechanical properties	
Weight	25 g

1) For additional information, see Automation Help (**Communication / POWERLINK / General information / Hardware - IF / LS**).

4.2.3.3.1 POWERLINK 1 interface - Pinout

The POWERLINK 1 interface on the system unit is referred to as "IF1".

POWERLINK 1 - IF1 ¹⁾		
Variant	RJ45, female	
Wiring	S/STP (Cat 5e)	
Cable length	Max. 100 m (min. Cat 5e)	
LED status indicator (b)	On	Off
Green	See status/error LED.	
LED "Link" (a)	On	Active
Yellow	Link (a connection to a POWERLINK network exists)	Blinking (data being transferred)

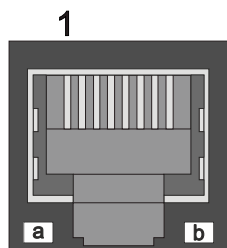

1) The interfaces, etc. available on the device or module have been numbered for the purpose of clear differentiation. This numbering may deviate from the numbering used by the respective operating system, however.

4.2.3.3.2 POWERLINK 2 interface - Pinout

The POWERLINK 2 interface on the system unit is referred to as "IFx".

POWERLINK 2 - IFx ¹⁾		
Variant	RJ45, female	
Wiring	S/STP (Cat 5e)	
Cable length	Max. 100 m (min. Cat 5e)	
LED status indicator (b)	On	Off
Green	See status/error LED.	
LED "Link" (a)	On	Active
Yellow	Link (a connection to a POWERLINK network exists)	Blinking (data being transferred)

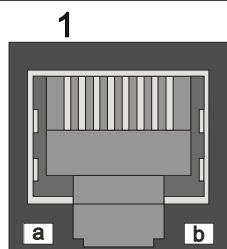

1) The interfaces, etc. available on the device or module have been numbered for the purpose of clear differentiation. This numbering may deviate from the numbering used by the respective operating system, however.

4.2.3.3.3 LED status indicators L1, L2, L3

The LEDs of the interface option are located near the ETH1 interface.

LED status indicators			
LED	Color	Status	Explanation
L1	Green	On	POWERLINK 2 link LED A connection to a POWERLINK network exists.
		Blinking	POWERLINK 2 link LED Data is being transferred.
L2	Green	On	POWERLINK 1 link LED A connection to a POWERLINK network exists.
		Blinking	POWERLINK 1 link LED Data is being transferred.
L3	Green-Red	On	POWERLINK status/error LED See "LED "S/E" (status/error LED)" on page 182.
		Off	POWERLINK status/error LED See "LED "S/E" (status/error LED)" on page 182.

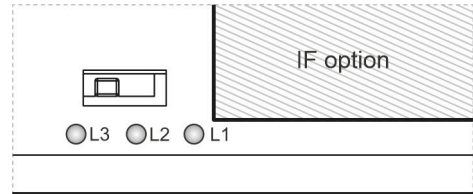

POWERLINK commissioning and operation

For a description of the operating modes, status and node numbers of the POWERLINK interface(s), see "LED "S/E" (status/error LED)" on page 182.

4.2.3.3.4 Driver support and firmware update

The driver is part of the Automation Runtime and the firmware is part of Automation Studio. The module is automatically brought up to this level.

To update the firmware contained in Automation Studio, a hardware upgrade must be performed (see **Project management / Workspace / Upgrades** in Automation Help).

4.2.3.4 5ACCIF01.FPLS-000

4.2.3.4.1 General information

Interface option 5ACCIF01.FPLS-000 is equipped with a POWERLINK and RS232 interface. In addition, 32 kB FRAM is installed.

- 1x POWERLINK interface managing or controlled node
- 1x RS232 interface
- 32 kB FRAM
- Compatible with APC2100/PPC2100 and APC2200/PPC2200

4.2.3.4.2 Order data

Order number	Short description	Figure
	Interface options	
5ACCIF01.FPLS-000	Interface card - 1x RS232 interface - 1x POWERLINK interface - 32 kB FRAM - For APC2100/PPC2100/APC2200/PPC2200 - Only available with a new device	
	Optional accessories	
	Terminal blocks	
0TB1210.3100	Connector 300 VDC - 10-pin female - Cage clamp terminal block - Protected against vibration by the screw flange	

4.2.3.4.3 Technical data

Information:

The following specified characteristic data, features and limit values are only valid for this accessory and may differ from those of the complete system. The data specified for the complete system applies to the complete system in which an accessory is used.

Order number	5ACCIF01.FPLS-000
General information	
LEDs	L2, L3
B&R ID code	0xE540
Certifications	
CE	Yes
UKCA	Yes
UL	cULus E115267 Industrial control equipment
HazLoc	cULus HazLoc E180196 Industrial control equipment for hazardous locations Class I, Division 2, Groups ABCD, T4
DNV	Temperature: B (0 to 55°C) Humidity: B (up to 100%) Vibration: A (0.7 g) EMC: B (bridge and open deck)
LR	ENV3
KR	Yes
ABS	Yes
BV	EC31B Temperature: 5 - 55°C Vibration: 0.7 g EMC: Bridge and open deck
Controller	
FRAM	
Size	32 kB
Data retention	10 years
Read/Write endurance	Min. 10 ¹² times/byte
Remanent variables in power failure mode	32 kB (for e.g. Automation Runtime, see Automation Help)
Interfaces	
COM	
Quantity	1
Type	RS232, modem supported, not galvanically isolated
Variant	10-pin, male
UART	16550-compatible, 16-byte FIFO buffer
Max. baud rate	115 kbit/s

Technical data

Order number	5ACCIF01.FPLS-000
POWERLINK	
Quantity	1
Type	Type 4 ¹⁾
Variant	RJ45, shielded
Transfer rate	100 Mbit/s
Transfer	100BASE-TX
Line length	Max. 100 m between two stations (segment length)
Electrical properties	
Power consumption	1.5 W
Operating conditions	
Pollution degree per EN 61131-2	Pollution degree 2
Ambient conditions	
Temperature	
Operation	-20 to 55°C
Storage	-20 to 60°C
Transport	-20 to 60°C
Relative humidity	
Operation	5 to 90%, non-condensing
Storage	5 to 95%, non-condensing
Transport	5 to 95%, non-condensing
Mechanical properties	
Weight	25 g

1) For additional information, see Automation Help (**Communication / POWERLINK / General information / Hardware - IF / LS**).

4.2.3.4.3.1 POWERLINK interface - Pinout

The POWERLINK interface on the system unit is referred to as "IF1".

POWERLINK - IF1 ¹⁾²⁾		
Variant	RJ45, female	
Wiring	S/STP (Cat 5e)	
Cable length	Max. 100 m (min. Cat 5e)	
LED status indicator (b)	On	Off
Green	See status/error LED.	
LED "Link" (a)	On	Active
Yellow	Link (a connection to a POWERLINK network exists)	Blinking (data being transferred)

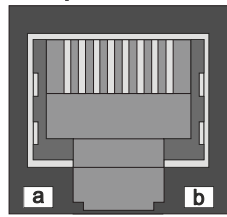

1) The interfaces, etc. available on the device or module have been numbered for the purpose of clear differentiation. This numbering may deviate from the numbering used by the respective operating system, however.

2) In Automation Studio / Automation Runtime, this interface is referred to as IF1.

4.2.3.4.3.2 Serial interface COMA - Pinout

Serial interface COMA on the system unit is referred to as "IFx".

Serial interface COMA - IFx ¹⁾²⁾³⁾		
RS232		
Variant	10-pin, male	
Type	RS232, modem supported	
Galvanic isolation	No	
UART	16550-compatible, 16-byte FIFO buffer	
Transfer rate	Max. 115 kbit/s	
Bus length	Max. 15 m	
	Pin	Pinout
	1	DCD
	2	DSR
	3	RXD
	4	RTS
	5	TXD
	6	CTS
	7	DTR
	8	RI
	9	GND
	10	Shield

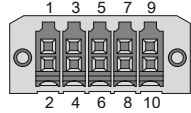

1) The interfaces, etc. available on the device or module have been numbered for the purpose of clear differentiation. This numbering may deviate from the numbering used by the respective operating system, however.

2) This interface (if available) is automatically enabled in BIOS as COMA with default addresses I/O:3F8h and IRQ:4.

3) In Automation Studio / Automation Runtime, this interface is referred to as IF5.

Cable data

For more detailed information about the transfer rate, bus length or cable requirements for the respective interfaces/buses, see "Cable data" on page 180.

4.2.3.4.3.3 LED status indicators L2, L3

The LEDs of the interface option are located near the ETH1 interface.

LED status indicators			
LED	Color	Status	Explanation
L1			Not connected
L2	Green	On	POWERLINK link LED A connection to a POWERLINK network exists.
		Blinking	POWERLINK link LED Data is being transferred.
L3	Green-Red	On	POWERLINK status/error LED See "LED "S/E" (status/error LED)" on page 182.
		Off	POWERLINK status/error LED See "LED "S/E" (status/error LED)" on page 182.

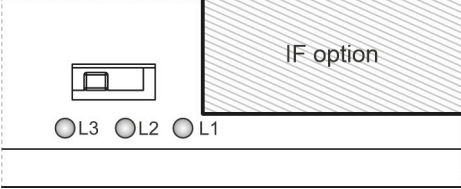

POWERLINK commissioning and operation

For a description of the operating modes, status and node numbers of the POWERLINK interface(s), see "LED "S/E" (status/error LED)" on page 182.

4.2.3.4.4 Shielding

For the interfaces on the 10-pin female connector, the shield of the interfaces can be connected to pin *Shield* (pin 2) of the female connector.

In addition, there is a functional ground connection on the interface cover of the system unit and a screw point for cable shields that can also be used for the shielded cables.

4.2.3.4.5 Driver support and firmware update

Drivers for approved operating systems are available for download in the Downloads section of the B&R website (www.br-automation.com) (if required and not already included in the operating system).

Approved operating systems:

- Automation Runtime
- Linux for B&R
- Windows 10
- Windows Embedded 8.1 Industry
- Windows 7
- Windows Embedded Standard 7

Automation Runtime / B&R Hypervisor (RTOS)

The driver is part of the Automation Runtime and the firmware is part of Automation Studio. The module is automatically brought up to this level.

To update the firmware contained in Automation Studio, a hardware upgrade must be performed (see **Project management / Workspace / Upgrades** in Automation Help).

All interfaces of the interface option are supported in Automation Runtime / B&R Hypervisor.

General purpose operating system (GPOS)

If this interface option is used with a GPOS, only operation of the serial port(s) is supported and the firmware update function cannot be used.

4.2.3.5 5ACCIF01.FPLS-001

4.2.3.5.1 General information

Interface option 5ACCIF01.FPLS-001 is equipped with a POWERLINK and RS232 interface. In addition, 512 kB nvSRAM is installed.

- 1x POWERLINK interface managing or controlled node
- 1x RS232 interface
- 512 kB nvSRAM
- Compatible with APC2100/PPC2100 and APC2200/PPC2200

4.2.3.5.2 Order data

Order number	Short description	Figure
	Interface options	
5ACCIF01.FPLS-001	Interface card - 1x RS232 interface - 1x POWERLINK interface - 512 kB nvSRAM - For APC2100/PPC2100/APC2200/PPC2200 - Only available with a new device	
	Optional accessories	
	Terminal blocks	
0TB1210.3100	Connector 300 VDC - 10-pin female - Cage clamp terminal block - Protected against vibration by the screw flange	

4.2.3.5.3 Technical data

Information:

The following specified characteristic data, features and limit values are only valid for this accessory and may differ from those of the complete system. The data specified for the complete system applies to the complete system in which an accessory is used.

Order number	5ACCIF01.FPLS-001
General information	
LEDs	L2, L3
B&R ID code	0xE9B9
Certifications	
CE	Yes
UKCA	Yes
UL	cULus E115267 Industrial control equipment
HazLoc	cULus HazLoc E180196 Industrial control equipment for hazardous locations Class I, Division 2, Groups ABCD, T4
DNV	Temperature: B (0 to 55°C) Humidity: B (up to 100%) Vibration: A (0.7 g) EMC: B (bridge and open deck)
LR	ENV3
ABS	Yes
BV	EC31B Temperature: 5 - 55°C Vibration: 0.7 g EMC: Bridge and open deck
Controller	
nvSRAM	
Size	512 kB
Data retention	20 years
Read/Write endurance	Min. 1,000,000
Battery-backed	No
Remanent variables in power failure mode	256 kB (for e.g. Automation Runtime, see Automation Help)
Interfaces	
COM	
Quantity	1
Type	RS232, modem supported, not galvanically isolated
Variant	10-pin, male
UART	16550-compatible, 16-byte FIFO buffer
Max. baud rate	115 kbit/s

Order number	5ACCIF01.FPLS-001
POWERLINK	
Quantity	1
Type	Type 4 ¹⁾
Variant	RJ45, shielded
Transfer rate	100 Mbit/s
Transfer	100BASE-TX
Line length	Max. 100 m between two stations (segment length)
Electrical properties	
Power consumption	1.5 W
Operating conditions	
Pollution degree per EN 61131-2	Pollution degree 2
Ambient conditions	
Temperature	
Operation	-20 to 55°C
Storage	-20 to 60°C
Transport	-20 to 60°C
Relative humidity	
Operation	5 to 90%, non-condensing
Storage	5 to 95%, non-condensing
Transport	5 to 95%, non-condensing
Mechanical properties	
Weight	25 g

1) For additional information, see Automation Help (**Communication / POWERLINK / General information / Hardware - IF / LS**).

4.2.3.5.3.1 POWERLINK interface - Pinout

The POWERLINK interface on the system unit is referred to as "IF1".

POWERLINK - IF1 ¹⁾²⁾		
Variant	RJ45, female	
Wiring	S/STP (Cat 5e)	
Cable length	Max. 100 m (min. Cat 5e)	
LED status indicator (b)	On	Off
Green	See status/error LED.	
LED "Link" (a)	On	Off
Yellow	Link (a connection to a POWERLINK network exists)	Blinking (data being transferred)

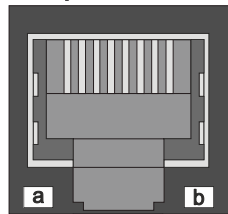

- 1) The interfaces, etc. available on the device or module have been numbered for the purpose of clear differentiation. This numbering may deviate from the numbering used by the respective operating system, however.
- 2) In Automation Studio / Automation Runtime, this interface is referred to as IF1.

4.2.3.5.3.2 Serial interface COMA - Pinout

Serial interface COMA on the system unit is referred to as "IFx".

Serial interface COMA - IFx ¹⁾²⁾³⁾		
RS232		
Variant	10-pin, male	
Type	RS232, modem supported	
Galvanic isolation	No	
UART	16550-compatible, 16-byte FIFO buffer	
Transfer rate	Max. 115 kbit/s	
Bus length	Max. 15 m	
	Pin	Pinout
	1	DCD
	2	DSR
	3	RXD
	4	RTS
	5	TXD
	6	CTS
	7	DTR
	8	RI
	9	GND
	10	Shield

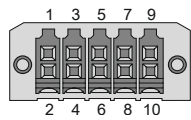

- 1) The interfaces, etc. available on the device or module have been numbered for the purpose of clear differentiation. This numbering may deviate from the numbering used by the respective operating system, however.
- 2) This interface (if available) is automatically enabled in BIOS as COMA with default addresses I/O:3F8h and IRQ:4.
- 3) In Automation Studio / Automation Runtime, this interface is referred to as IF5.

Cable data

For more detailed information about the transfer rate, bus length or cable requirements for the respective interfaces/buses, see "Cable data" on page 180.

4.2.3.5.3.3 LED status indicators L2, L3

The LEDs of the interface option are located near the ETH1 interface.

LED status indicators			
LED	Color	Status	Explanation
L1			Not connected
L2	Green	On	POWERLINK link LED A connection to a POWERLINK network exists.
		Blinking	POWERLINK link LED Data is being transferred.
L3	Green-Red	On	POWERLINK status/error LED See "LED "S/E" (status/error LED)" on page 182.
		Off	POWERLINK status/error LED See "LED "S/E" (status/error LED)" on page 182.

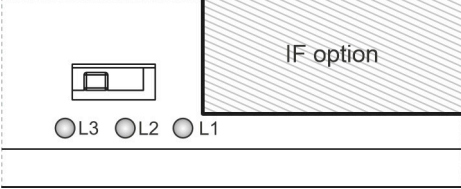

The diagram shows a 10-pin female connector with a shield. Below the connector, three LEDs are labeled L3, L2, and L1 from left to right. A shaded rectangular area labeled 'IF option' is positioned to the right of the connector, indicating the location of the interface option.

POWERLINK commissioning and operation

For a description of the operating modes, status and node numbers of the POWERLINK interface(s), see "LED "S/E" (status/error LED)" on page 182.

4.2.3.5.4 Shielding

For the interfaces on the 10-pin female connector, the shield of the interfaces can be connected to pin *Shield* (pin 2) of the female connector.

In addition, there is a functional ground connection on the interface cover of the system unit and a screw point for cable shields that can also be used for the shielded cables.

4.2.3.5.5 Driver support and firmware update

Drivers for approved operating systems are available for download in the Downloads section of the B&R website (www.br-automation.com) (if required and not already included in the operating system).

Approved operating systems:

- Automation Runtime
- Linux for B&R
- Windows 10
- Windows Embedded 8.1 Industry
- Windows 7
- Windows Embedded Standard 7

Automation Runtime / B&R Hypervisor (RTOS)

The driver is part of the Automation Runtime and the firmware is part of Automation Studio. The module is automatically brought up to this level.

To update the firmware contained in Automation Studio, a hardware upgrade must be performed (see **Project management / Workspace / Upgrades** in Automation Help).

All interfaces of the interface option are supported in Automation Runtime / B&R Hypervisor.

General purpose operating system (GPOS)

If this interface option is used with a GPOS, only operation of the serial port(s) is supported and the firmware update function cannot be used.

4.2.3.6 5ACCIF01.FPSC-000

4.2.3.6.1 General information

Interface option 5ACCIF01.FPSC-000 is equipped with a POWERLINK, RS232 and CAN bus master interface. In addition, 32 kB FRAM is installed.

- 1x POWERLINK interface managing or controlled node
- 1x CAN bus master interface
- 1x RS232 interface
- 32 kB FRAM
- Compatible with APC2100/PPC2100 and APC2200/PPC2200

This interface option can only be operated with Automation Runtime.

4.2.3.6.2 Order data

Order number	Short description	Figure
5ACCIF01.FPSC-000	Interface options Interface card - 1x RS232 interface - 1x CAN interface - 1x POWERLINK interface - 32 kB FRAM - For APC2100/PPC2100/ APC2200/PPC2200 - Only available with a new device	
	Optional accessories	
	Terminal blocks	
0TB1210.3100	Connector 300 VDC - 10-pin female - Cage clamp terminal block - Protected against vibration by the screw flange	

4.2.3.6.3 Technical data

Information:

The following specified characteristic data, features and limit values are only valid for this accessory and may differ from those of the complete system. The data specified for the complete system applies to the complete system in which an accessory is used.

Order number	5ACCIF01.FPSC-000
General information	
LEDs	L1, L2, L3
B&R ID code	0xE53F
Certifications	
CE	Yes
UKCA	Yes
UL	cULus E115267 Industrial control equipment
HazLoc	cULus HazLoc E180196 Industrial control equipment for hazardous locations Class I, Division 2, Groups ABCD, T4
DNV	Temperature: B (0 to 55°C) Humidity: B (up to 100%) Vibration: A (0.7 g) EMC: B (bridge and open deck)
LR	ENV3
KR	Yes
ABS	Yes
BV	EC31B Temperature: 5 - 55°C Vibration: 0.7 g EMC: Bridge and open deck
Controller	
FRAM	
Size	32 kB
Data retention	10 years
Read/Write endurance	Min. 10 ¹² times/byte
Remanent variables in power failure mode	32 kB (for e.g. Automation Runtime, see Automation Help)
Interfaces	
COM	
Quantity	1
Type	RS232, modem not supported, not galvanically isolated
Variant	10-pin, male
UART	16550-compatible, 16-byte FIFO buffer
Max. baud rate	115 kbit/s

Technical data

Order number	5ACCIF01.FPSC-000
POWERLINK	
Quantity	1
Type	Type 4 ¹⁾
Variant	RJ45, shielded
Transfer rate	100 Mbit/s
Transfer	100BASE-TX
Line length	Max. 100 m between two stations (segment length)
CAN	
Quantity	1
Variant	10-pin, male, not galvanically isolated
Transfer rate	Max. 1 Mbit/s
Terminating resistor	
Type	Can be switched on and off with slide switch
Default setting	Off
Electrical properties	
Power consumption	1.75 W
Operating conditions	
Pollution degree per EN 61131-2	Pollution degree 2
Ambient conditions	
Temperature	
Operation	-20 to 55°C
Storage	-20 to 60°C
Transport	-20 to 60°C
Relative humidity	
Operation	5 to 90%, non-condensing
Storage	5 to 95%, non-condensing
Transport	5 to 95%, non-condensing
Mechanical properties	
Weight	25 g

1) For additional information, see Automation Help (**Communication / POWERLINK / General information / Hardware - IF / LS**).

4.2.3.6.3.1 POWERLINK interface - Pinout

The POWERLINK interface on the system unit is referred to as "IF1".

POWERLINK - IF1 ¹⁾²⁾		
Variant	RJ45, female	
Wiring	S/STP (Cat 5e)	
Cable length	Max. 100 m (min. Cat 5e)	
LED status indicator (b)	On	Off
Green	See status/error LED.	
LED "Link" (a)	On	Active
Yellow	Link (a connection to a POWERLINK network exists)	Blinking (data being transferred)

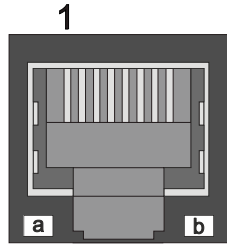

The diagram shows a female RJ45 connector labeled '1'. The connector has eight pins. Two pins at the bottom are labeled 'a' and 'b', corresponding to the LED indicators described in the table above.

- 1) The interfaces, etc. available on the device or module have been numbered for the purpose of clear differentiation. This numbering may deviate from the numbering used by the respective operating system, however.
- 2) In Automation Studio / Automation Runtime, this interface is referred to as IF1.

4.2.3.6.3.2 Serial interface COM - Pinout

Serial interface COM on the system unit is referred to as "IFx".

Serial interface COM - IFx ^(1,2)	
RS232	
Variant	10-pin, male
Type	RS232, not modem supported
Galvanic isolation	No
UART	16550-compatible, 16-byte FIFO buffer
Transfer rate	Max. 115 kbit/s
Bus length	Max. 15 m
Pin	Pinout
1	-
2	Shield
3	-
4	-
5	-
6	-
7	-
8	COM GND
9	RXD
10	TXD

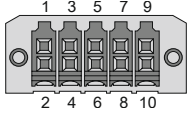

- 1) The interfaces, etc. available on the device or module have been numbered for the purpose of clear differentiation. This numbering may deviate from the numbering used by the respective operating system, however.
- 2) This interface can only be used in Automation Runtime and is displayed as IF5 in Automation Studio / Automation Runtime. It is not a "PC interface" and therefore not displayed in BIOS.

Cable data

For more detailed information about the transfer rate, bus length or cable requirements for the respective interfaces/buses, see "Cable data" on page 180.

4.2.3.6.3.3 CAN bus interface - Pinout

The CAN bus interface on the system unit is referred to as "IFx".

CAN bus - IFx ^(1,2)	
Variant	10-pin, male
Galvanic isolation	No
Transfer rate	Max. 1 Mbit/s
Bus length	Max. 1000 m
Pin	Pinout
1	-
2	Shield
3	-
4	-
5	CAN H
6	CAN L
7	CAN GND
8	-
9	-
10	-

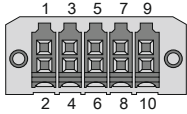

- 1) The interfaces, etc. available on the device or module have been numbered for the purpose of clear differentiation. This numbering may deviate from the numbering used by the respective operating system, however.
- 2) This interface can only be used in Automation Runtime and is displayed as IF3 in Automation Studio / Automation Runtime. It is not a "PC interface" and therefore not displayed in BIOS.

CAN driver settings

The baud rate can be set either with "predefined values" or via the "bit timing register".

For additional information, see Automation Help.

Bit timing register 0	Bit timing register 1	Baud rate
00h	14h	1000 kbit/s
80h or 00h	1Ch	500 kbit/s
81h or 01h	1Ch	250 kbit/s
83h or 03h	1Ch	125 kbit/s
84h or 04h	1Ch	100 kbit/s
89h or 09h	1Ch	50 kbit/s

Cable data

For more detailed information about the transfer rate, bus length or cable requirements for the respective interfaces/buses, see "Cable data" on page 180.

Terminating resistor

A terminating resistor is integrated on the interface option. It is switched on or off for the CAN bus interface with a switch. LED status indicator L1 indicates the current state:

- ON: Activated
- OFF (default): Switched off

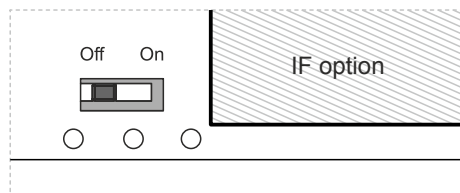

4.2.3.6.3.4 LED status indicators L1, L2, L3

The LEDs of the interface option are located near the ETH1 interface.

LED status indicators			
LED	Color	Status	Explanation
L1	Yellow	On	The CAN bus terminating resistor is switched on.
		Off	The CAN bus terminating resistor is switched off.
L2	Green	On	POWERLINK link LED A connection to a POWERLINK network exists.
		Blinking	POWERLINK link LED Data is being transferred.
L3	Green-Red	On	POWERLINK status/error LED See "LED "S/E" (status/error LED)" on page 182.
		Off	POWERLINK status/error LED See "LED "S/E" (status/error LED)" on page 182.

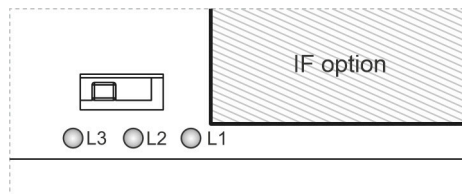

POWERLINK commissioning and operation

For a description of the operating modes, status and node numbers of the POWERLINK interface(s), see "LED "S/E" (status/error LED)" on page 182.

4.2.3.6.4 Shielding

For the interfaces on the 10-pin female connector, the shield of the interfaces can be connected to pin *Shield* (pin 2) of the female connector.

In addition, there is a functional ground connection on the interface cover of the system unit and a screw point for cable shields that can also be used for the shielded cables.

4.2.3.6.5 Driver support and firmware update

The driver is part of the Automation Runtime and the firmware is part of Automation Studio. The module is automatically brought up to this level.

To update the firmware contained in Automation Studio, a hardware upgrade must be performed (see **Project management / Workspace / Upgrades** in Automation Help).

4.2.3.7 5ACCIF01.FPSC-001

4.2.3.7.1 General information

Interface option 5ACCIF01.FPSC-001 is equipped with a POWERLINK, RS232, CAN bus master and X2X Link master interface. In addition, 512 kB nvSRAM is installed.

- 1x POWERLINK interface managing or controlled node
- 1x CAN bus master interface
- 1x X2X Link master interface
- 1x RS232 interface
- 512 kB nvSRAM
- Compatible with APC2100/PC2100 and APC2200/PPC2200

This interface option can only be operated with Automation Runtime.

4.2.3.7.2 Order data

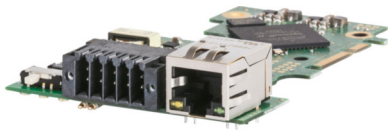
Order number	Short description	Figure
	Interface options	
5ACCIF01.FPSC-001	Interface card - 1x RS232 interface - 1x CAN interface - 1x X2X Link Interface - 1x POWERLINK interface - 512 kB nvSRAM - For APC2100/PPC2100/APC2200/PPC2200 - Only available with a new device	
	Optional accessories	
	Terminal blocks	
0TB1210.3100	Connector 300 VDC - 10-pin female - Cage clamp terminal block - Protected against vibration by the screw flange	

4.2.3.7.3 Technical data

Information:

The following specified characteristic data, features and limit values are only valid for this accessory and may differ from those of the complete system. The data specified for the complete system applies to the complete system in which an accessory is used.

Order number	5ACCIF01.FPSC-001
General information	
LEDs	L1, L2, L3
B&R ID code	0xE9BC
Certifications	
CE	Yes
UKCA	Yes
UL	cULus E115267 Industrial control equipment
HazLoc	cULus HazLoc E180196 Industrial control equipment for hazardous locations Class I, Division 2, Groups ABCD, T4
DNV	Temperature: B (0 to 55°C) Humidity: B (up to 100%) Vibration: A (0.7 g) EMC: B (bridge and open deck)
LR	ENV3
ABS	Yes
BV	EC31B Temperature: 5 - 55°C Vibration: 0.7 g EMC: Bridge and open deck
Controller	
nvSRAM	
Size	512 kB
Data retention	20 years
Read/Write endurance	Min. 1,000,000
Battery-backed	No
Remanent variables in power failure mode	256 kB (for e.g. Automation Runtime, see Automation Help)
Interfaces	
COM	
Quantity	1
Type	RS232, modem not supported, not galvanically isolated
Variant	10-pin, male
UART	16550-compatible, 16-byte FIFO buffer
Max. baud rate	115 kbit/s

Technical data

Order number	5ACCIF01.FPSC-001
POWERLINK	
Quantity	1
Type	Type 4 ¹⁾
Variant	RJ45, shielded
Transfer rate	100 Mbit/s
Transfer	100BASE-TX
Line length	Max. 100 m between two stations (segment length)
CAN	
Quantity	1
Variant	10-pin, male, galvanically isolated
Transfer rate	Max. 1 Mbit/s
Terminating resistor	
Type	Can be switched on and off with slide switch
Default setting	Off
X2X	
Type	X2X Link master
Quantity	1
Variant	10-pin, male, galvanically isolated
Electrical properties	
Power consumption	2 W
Operating conditions	
Pollution degree per EN 61131-2	Pollution degree 2
Ambient conditions	
Temperature	
Operation	-20 to 55°C
Storage	-20 to 60°C
Transport	-20 to 60°C
Relative humidity	
Operation	5 to 90%, non-condensing
Storage	5 to 95%, non-condensing
Transport	5 to 95%, non-condensing
Mechanical properties	
Weight	25 g

1) For additional information, see Automation Help (**Communication / POWERLINK / General information / Hardware - IF / LS**).

4.2.3.7.3.1 POWERLINK interface - Pinout

The POWERLINK interface on the system unit is referred to as "IF1".

POWERLINK - IF1 ¹⁾²⁾		
Variant	RJ45, female	
Wiring	S/STP (Cat 5e)	
Cable length	Max. 100 m (min. Cat 5e)	
LED status indicator (b)	On	Off
Green	See status/error LED.	
LED "Link" (a)	On	Active
Yellow	Link (a connection to a POWERLINK network exists)	Blinking (data being transferred)

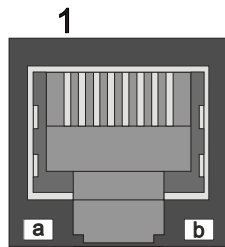

The diagram shows a 10-pin RJ45 female connector. Above the connector is the number '1'. Below the connector are two LEDs labeled 'a' and 'b'. LED 'a' is yellow and LED 'b' is green.

1) The interfaces, etc. available on the device or module have been numbered for the purpose of clear differentiation. This numbering may deviate from the numbering used by the respective operating system, however.

2) In Automation Studio / Automation Runtime, this interface is referred to as IF1.

4.2.3.7.3.2 Serial interface COM - Pinout

Serial interface COM on the system unit is referred to as "IFx".

Serial interface COM - IFx ^(1,2)	
RS232	
Variant	10-pin, male
Type	RS232, not modem supported
Galvanic isolation	No
UART	16550-compatible, 16-byte FIFO buffer
Transfer rate	Max. 115 kbit/s
Bus length	Max. 15 m
Pin	Pinout
1	-
2	Shield
3	-
4	-
5	-
6	-
7	-
8	COM GND
9	RXD
10	TXD

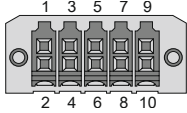

- 1) The interfaces, etc. available on the device or module have been numbered for the purpose of clear differentiation. This numbering may deviate from the numbering used by the respective operating system, however.
- 2) This interface can only be used in Automation Runtime and is displayed as IF5 in Automation Studio / Automation Runtime. It is not a "PC interface" and therefore not displayed in BIOS.

Cable data

For more detailed information about the transfer rate, bus length or cable requirements for the respective interfaces/buses, see "Cable data" on page 180.

4.2.3.7.3.3 CAN bus interface - Pinout

The CAN bus interface on the system unit is referred to as "IFx".

CAN bus - IFx ^(1,2)	
Variant	10-pin, male
Galvanic isolation	Yes
Transfer rate	Max. 1 Mbit/s
Bus length	Max. 1000 m
Pin	Pinout
1	-
2	Shield
3	-
4	-
5	CAN H
6	CAN L
7	CAN GND
8	-
9	-
10	-

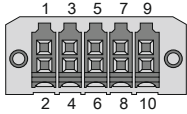

- 1) The interfaces, etc. available on the device or module have been numbered for the purpose of clear differentiation. This numbering may deviate from the numbering used by the respective operating system, however.
- 2) This interface can only be used in Automation Runtime and is displayed as IF3 in Automation Studio / Automation Runtime. It is not a "PC interface" and therefore not displayed in BIOS.

CAN driver settings

The baud rate can be set either with "predefined values" or via the "bit timing register".

For additional information, see Automation Help.

Bit timing register 0	Bit timing register 1	Baud rate
00h	14h	1000 kbit/s
80h or 00h	1Ch	500 kbit/s
81h or 01h	1Ch	250 kbit/s
83h or 03h	1Ch	125 kbit/s
84h or 04h	1Ch	100 kbit/s
89h or 09h	1Ch	50 kbit/s

Cable data

For more detailed information about the transfer rate, bus length or cable requirements for the respective interfaces/buses, see "Cable data" on page 180.

Terminating resistor

A terminating resistor is integrated on the interface option. It is switched on or off for the CAN bus interface with a switch. LED status indicator L1 indicates the current state:

- ON: Activated
- OFF (default): Switched off

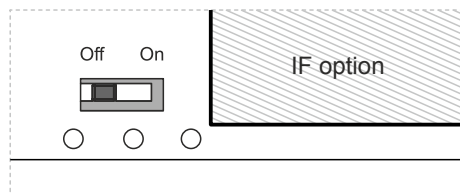

4.2.3.7.3.4 X2X Link master interface - Pinout

The X2X Link master interface on the system unit is referred to as "IFx".

X2X Link master - IFx ¹⁾²⁾	
Variant	10-pin, male
Galvanic isolation	Yes
Pin	Pinout
1	X2X
2	Shield
3	X2X _I
4	X2X _L
5	-
6	-
7	-
8	-
9	-
10	-

- 1) The interfaces, etc. available on the device or module have been numbered for the purpose of clear differentiation. This numbering may deviate from the numbering used by the respective operating system, however.
- 2) This interface can only be used in Automation Runtime and is displayed as IF2 in Automation Studio / Automation Runtime. It is not a "PC interface" and therefore not displayed in BIOS.

4.2.3.7.3.5 LED status indicators L1, L2, L3

The LEDs of the interface option are located near the ETH1 interface.

LED status indicators			
LED	Color	Status	Explanation
L1	Yellow	On	The CAN bus terminating resistor is switched on.
		Off	The CAN bus terminating resistor is switched off.
L2	Green	On	POWERLINK link LED A connection to a POWERLINK network exists.
		Blinking	POWERLINK link LED Data is being transferred.
L3	Green-Red	On	POWERLINK status/error LED See "LED "S/E" (status/error LED)" on page 182.
		Off	POWERLINK status/error LED See "LED "S/E" (status/error LED)" on page 182.

POWERLINK commissioning and operation

For a description of the operating modes, status and node numbers of the POWERLINK interface(s), see "LED "S/E" (status/error LED)" on page 182.

4.2.3.7.4 Shielding

For the interfaces on the 10-pin female connector, the shield of the interfaces can be connected to pin *Shield* (pin 2) of the female connector.

In addition, there is a functional ground connection on the interface cover of the system unit and a screw point for cable shields that can also be used for the shielded cables.

4.2.3.7.5 Driver support and firmware update

The driver is part of the Automation Runtime and the firmware is part of Automation Studio. The module is automatically brought up to this level.

To update the firmware contained in Automation Studio, a hardware upgrade must be performed (see **Project management / Workspace / Upgrades** in Automation Help).

4.2.3.8 5ACCIF01.FSS0-000

4.2.3.8.1 General information

Interface option 5ACCIF01.FSS0-000 is equipped with 2 RS422/RS485 interfaces.

- 2x RS422/RS485 interfaces
- Compatible with APC2100/PPC2100 and APC2200/PPC2200

4.2.3.8.2 Order data

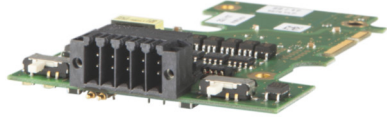
Order number	Short description	Figure
5ACCIF01.FSS0-000	Interface card - 2x RS422/RS485 interface - For APC2100/PPC2100/APC2200/PPC2200 - Only available with a new device	
	Optional accessories	
	Terminal blocks	
0TB1210.3100	Connector 300 VDC - 10-pin female - Cage clamp terminal block - Protected against vibration by the screw flange	

4.2.3.8.3 Technical data

Information:

The following specified characteristic data, features and limit values are only valid for this accessory and may differ from those of the complete system. The data specified for the complete system applies to the complete system in which an accessory is used.

Order number	5ACCIF01.FSS0-000
General information	
LEDs	L2, L3
B&R ID code	0xED7B
Certifications	
CE	Yes
UKCA	Yes
UL	cULus E115267 Industrial control equipment
HazLoc	cULus HazLoc E180196 Industrial control equipment for hazardous locations Class I, Division 2, Groups ABCD, T4
DNV	Temperature: B (0 to 55°C) Humidity: B (up to 100%) Vibration: A (0.7 g) EMC: B (bridge and open deck)
LR	ENV3
ABS	Yes
BV	EC31B Temperature: 5 - 55°C Vibration: 0.7 g EMC: Bridge and open deck
Interfaces	
COM	
Quantity	2
Type	RS422/RS485, galvanically isolated
Variant	10-pin, male
UART	16550-compatible, 16-byte FIFO buffer
Max. baud rate	115 kbit/s
Terminating resistor	
Type	Can be switched on and off with slide switch
Default setting	Off
Electrical properties	
Power consumption	1 W
Operating conditions	
Pollution degree per EN 61131-2	Pollution degree 2
Ambient conditions	
Temperature	
Operation	-20 to 60°C ¹⁾
Storage	-20 to 60°C
Transport	-20 to 60°C

Order number	5ACCIF01.FSS0-000
Relative humidity	
Operation	5 to 90%, non-condensing
Storage	5 to 95%, non-condensing
Transport	5 to 95%, non-condensing
Mechanical properties	
Weight	25 g

1) For detailed information, see the temperature tables in the user's manual.

4.2.3.8.3.1 Serial interface COM A - Pinout

Serial interface COM A on the system unit is referred to as "IFx".

Serial interface COM A - IFx ¹⁾²⁾³⁾	
RS422/RS485	
Variant	10-pin, male
Type	RS422/RS485
Galvanic isolation	Yes
UART	16550-compatible, 16-byte FIFO buffer
Transfer rate	Max. 115 kbit/s
Bus length	Max. 1200 m
Pin	Pinout
1	-
2	-
3	-
4	-
5	-
6	COM GND
7	TXD
8	TXD\
9	RXD
10	RXD\

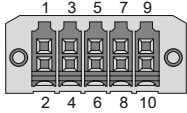

- 1) The interfaces, etc. available on the device or module have been numbered for the purpose of clear differentiation. This numbering may deviate from the numbering used by the respective operating system, however.
- 2) This interface (if available) is automatically enabled in BIOS as COM A with default addresses I/O:3F8h and IRQ:4.
- 3) This interface is displayed as IF7 in Automation Studio / Automation Runtime.

Cable data

For more detailed information about the transfer rate, bus length or cable requirements for the respective interfaces/buses, see "Cable data" on page 180.

Operation as RS485 interface

The pins of the RS422 default interface (7, 8, 9 and 10) must be used for operation. To do this, connect the pins as shown.

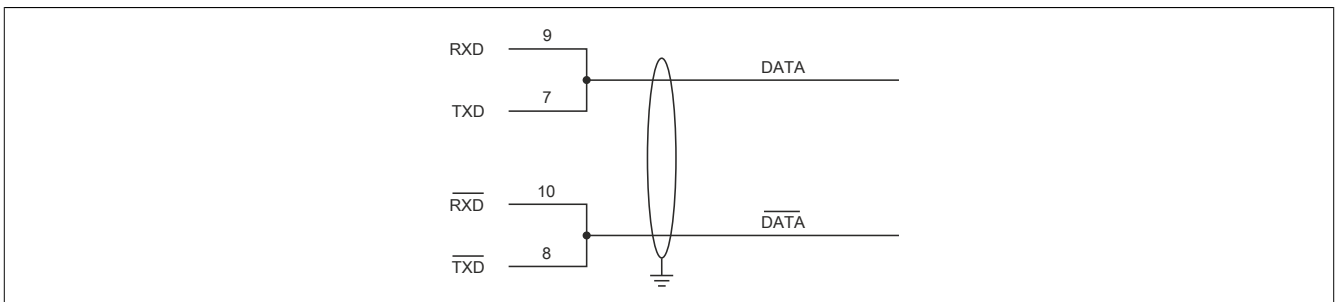

The RTS line must be switched by the driver for each transmission or reception; switching back does not take place automatically. This cannot be configured in Windows.

With long cable lengths, the voltage drop can result in greater potential differences between the bus devices, which can hinder communication. This can be improved by running the ground wire with the others.

The cable ends of an RS485 bus should be terminated (at least for longer cable lengths or higher transfer rates). Passive termination can normally be used by connecting the signal lines via a 120 Ω resistor at each of the two bus ends; see "Terminating resistor" for the IF card.

4.2.3.8.3.2 Serial interface COM D - Pinout

Serial interface COM D on the system unit is referred to as "IFx".

Serial interface COMD - IFx ¹⁾²⁾³⁾	
RS422/RS485	
Variant	10-pin, male
Type	RS422/RS485
Galvanic isolation	Yes
UART	16550-compatible, 16-byte FIFO buffer
Transfer rate	Max. 115 kbit/s
Bus length	Max. 1200 m
Pin	Pinout
1	RXD
2	RXD\
3	TXD
4	TXD\
5	COM GND
6	-
7	-
8	-
9	-
10	-

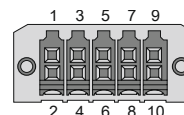

- 1) The interfaces, etc. available on the device or module have been numbered for the purpose of clear differentiation. This numbering may deviate from the numbering used by the respective operating system, however.
- 2) This interface (if available) is automatically enabled in BIOS as COM D with default addresses I/O:2E8h and IRQ:10.
- 3) This interface is displayed as IF8 in Automation Studio / Automation Runtime.

Operating COM D as an RS485 interface

The pins of the RS422 default interface (1, 2, 3 and 4) must be used for operation. To do this, connect the pins as shown.

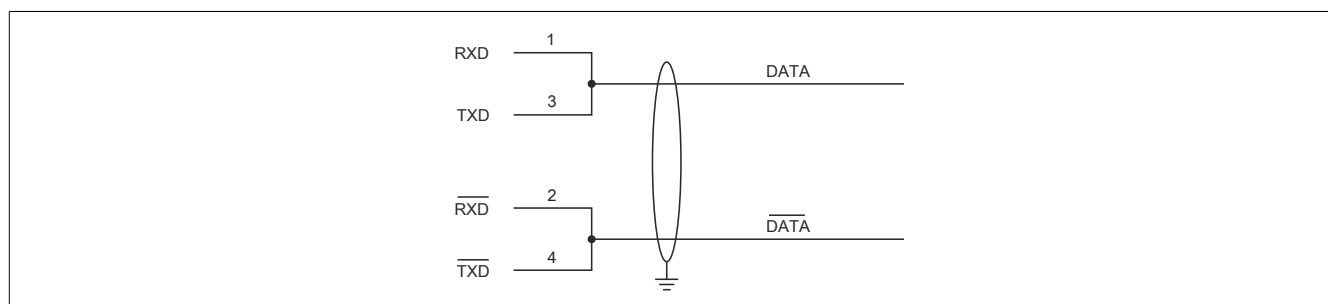

The RTS line must be switched by the driver for each transmission or reception; switching back does not take place automatically. This cannot be configured in Windows.

With long cable lengths, the voltage drop can result in greater potential differences between the bus devices, which can hinder communication. This can be improved by running the ground wire with the others.

The cable ends of an RS485 bus should be terminated (at least for longer cable lengths or higher transfer rates). Passive termination can normally be used by connecting the signal lines via a 120 Ω resistor at each of the two bus ends; see "Terminating resistor" for the IF card.

4.2.3.8.3.3 LED status indicators L2, L3

The LEDs of the interface option are located near the ETH1 interface.

LED status indicators			
LED	Color	Status	Explanation
L1			Not connected
L2	Yellow	On	The COM D terminating resistor is switched on.
		Off	The COM D terminating resistor is switched off.
L3	Yellow	On	The COM A terminating resistor is switched on.
		Off	The COM A terminating resistor is switched off.

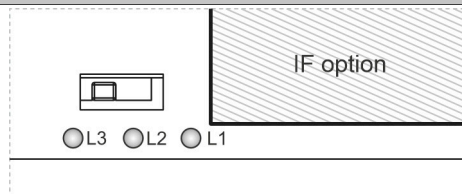

4.2.3.8.3.4 Terminating resistor

One terminating resistor per COM is integrated on the interface option; they are located to the left and right of the RS422/RS485 interface. Both can be switched on or off with a switch. LED status indicators L2 and L3 (see "[LED status indicators L2, L3](#)" on page 80) indicate the state of the assigned terminating resistor:

- ON: Switched on
- OFF (default): Switched off

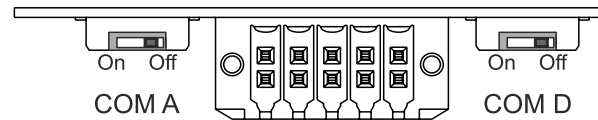

4.2.3.8.3.5 Firmware

In order to ensure the functionality of the interface option, at least the following firmware version (MTCX) must be installed on the PC:

- Automation PC 2100: V1.10
- Panel PC 2100: V1.10

The firmware can be downloaded from the B&R website (www.br-automation.com).

For information about upgrading the firmware, see section "[Upgrading the firmware on the Automation PC 2100](#)" on page 132.

4.2.3.8.3.6 Hardware

In order to ensure the functionality of the interface option, the PC must have at least the following hardware revision:

- 5APC2100.BY01-000 - Rev. H0 or later
- 5APC2100.BY11-000 - Rev. G0 or later
- 5APC2100.BY22-000 - Rev. H0 or later
- 5APC2100.BY34-000 - Rev. H0 or later
- 5APC2100.BY44-000 - Rev. H0 or later
- 5APC2100.BY48-000 - Rev. D0 or later

4.2.3.8.4 Shielding

For the interfaces on the 10-pin female connector, the shield of the interfaces can be connected to pin *Shield* (pin 2) of the female connector.

In addition, there is a functional ground connection on the interface cover of the system unit and a screw point for cable shields that can also be used for the shielded cables.

4.2.3.8.5 Driver support

Drivers for approved operating systems are available for download in the Downloads section of the B&R website (www.br-automation.com) (if required and not already included in the operating system).

Approved operating systems:

- Automation Runtime
- Linux for B&R
- Windows 10
- Windows Embedded 8.1 Industry
- Windows 7
- Windows Embedded Standard 7

4.2.3.9 5ACCIF01.ICAN-000

4.2.3.9.1 General information

Interface option 5ACCIF01.ICAN-000 is equipped with a CAN bus master interface.

- 1x CAN bus master interface
- Compatible with APC2100/PPC2100 and APC2200/PPC2200

4.2.3.9.2 Order data

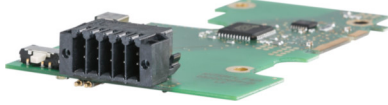
Order number	Short description	Figure
5ACCIF01.ICAN-000	Interface options Interface card - 1x CAN interface - For APC2100/PPC2100/ APC2200/PPC2200 - Only available with a new device	
	Optional accessories	
	Terminal blocks	
0TB1210.3100	Connector 300 VDC - 10-pin female - Cage clamp terminal block - Protected against vibration by the screw flange	

4.2.3.9.3 Technical data

Information:

The following specified characteristic data, features and limit values are only valid for this accessory and may differ from those of the complete system. The data specified for the complete system applies to the complete system in which an accessory is used.

Order number	5ACCIF01.ICAN-000
General information	
LEDs	L1
B&R ID code	0xE9BB
Certifications	
CE	Yes
UKCA	Yes
UL	cULus E115267 Industrial control equipment
HazLoc	cULus HazLoc E180196 Industrial control equipment for hazardous locations Class I, Division 2, Groups ABCD, T4
Interfaces	
CAN	
Quantity	1
Controller	Bosch CC770 (compatible with Intel 82527 CAN controller)
Variant	10-pin, male, galvanically isolated
Transfer rate	Max. 1 Mbit/s
Terminating resistor	
Type	Can be switched on and off with slide switch
Default setting	Off
Electrical properties	
Power consumption	0.5 W
Operating conditions	
Pollution degree per EN 61131-2	Pollution degree 2
Ambient conditions	
Temperature	
Operation	-20 to 60°C ¹⁾
Storage	-20 to 60°C
Transport	-20 to 60°C
Relative humidity	
Operation	5 to 90%, non-condensing
Storage	5 to 95%, non-condensing
Transport	5 to 95%, non-condensing
Mechanical properties	
Weight	25 g

1) For detailed information, see the temperature tables in the user's manual.

4.2.3.9.3.1 CAN bus interface - Pinout

The CAN bus interface on the system unit is referred to as "IFx".

CAN bus - IFx ¹⁾²⁾	
Variant	10-pin, male
Galvanic isolation	Yes
Transfer rate	Max. 1 Mbit/s
Bus length	Max. 1000 m
Pin	Pinout
1	-
2	CAN shield
3	-
4	-
5	CAN H
6	CAN L
7	CAN GND
8	-
9	-
10	-

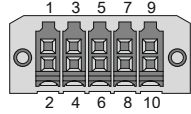

- 1) The interfaces, etc. available on the device or module have been numbered for the purpose of clear differentiation. This numbering may deviate from the numbering used by the respective operating system, however.
- 2) This interface (if available) is automatically enabled in BIOS as CAN with default addresses I/O:384h/385h and IRQ:10.

I/O address and IRQ

Resource	Default setting	Function
I/O address	384h (address register)	Defines the register number to be accessed.
	385h (data register)	Access to the register defined in the address register.
IRQ	IRQ:10	Interrupt

CAN driver settings

The baud rate can be set either with "predefined values" or via the "bit timing register".
 For additional information about operation with Automation Runtime, see Automation Help.
 For additional information about operation with approved GPOS, see the user's manual for the B&R CAN driver at www.br-automation.com.

Bit timing register 0	Bit timing register 1	Baud rate
00h	14h	1000 kbit/s
80h or 00h	1Ch	500 kbit/s
81h or 01h	1Ch	250 kbit/s
83h or 03h	1Ch	125 kbit/s
84h or 04h	1Ch	100 kbit/s
89h or 09h	1Ch	50 kbit/s

Terminating resistor

A terminating resistor is integrated on the interface option. It is switched on or off for the CAN bus interface with a switch. LED status indicator L1 indicates the current state:

- ON: Activated
- OFF (default): Switched off

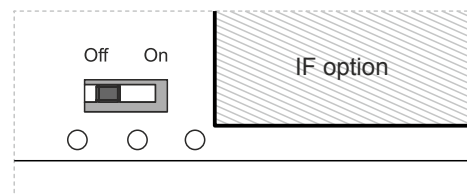

4.2.3.9.3.2 LED status indicator L1

The LEDs of the interface option are located near the ETH1 interface.

LED status indicator			
LED	Color	Status	Explanation
L1	Yellow	On	The CAN bus terminating resistor is switched on.
		Off	The CAN bus terminating resistor is switched off.
L2			Not connected
L3			Not connected
			-

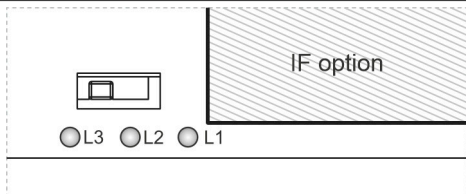

4.2.3.9.3.3 Firmware

In order to ensure the functionality of the interface option, at least the following firmware version (MTCX) must be installed on the PC:

- Automation PC 2100: V1.06
- Panel PC 2100: V1.06

The firmware can be downloaded from the B&R website (www.br-automation.com).

For information about upgrading the firmware, see section "Upgrading the firmware on the Automation PC 2100" on page 132.

4.2.3.9.4 Shielding

For the interfaces on the 10-pin female connector, the shield of the interfaces can be connected to pin *Shield* (pin 2) of the female connector.

In addition, there is a functional ground connection on the interface cover of the system unit and a screw point for cable shields that can also be used for the shielded cables.

4.2.3.9.5 Driver support

Drivers for approved operating systems are available for download in the Downloads section of the B&R website (www.br-automation.com) (if required and not already included in the operating system).

Approved operating systems:

- Automation Runtime
- Linux for B&R
- Windows 10
- Windows Embedded 8.1 Industry
- Windows 7
- Windows Embedded Standard 7

4.2.3.10 5ACCIF01.IS00-000

4.2.3.10.1 General information

Interface option 5ACCIF01.IS00-000 is equipped with an RS232 interface.

- 1x RS232 interface
- Compatible with APC2100/PPC2100 and APC2200/PPC2200

4.2.3.10.2 Order data

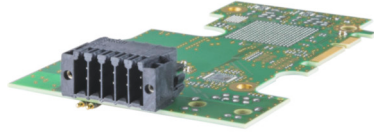
Order number	Short description	Figure
	Interface options	
5ACCIF01.IS00-000	Interface card - 1x RS232 interface - For APC2100/PPC2100/ APC2200/PPC2200 - Only available with a new device	
	Optional accessories	
	Terminal blocks	
0TB1210.3100	Connector 300 VDC - 10-pin female - Cage clamp terminal block - Protected against vibration by the screw flange	

4.2.3.10.3 Technical data

Information:

The following specified characteristic data, features and limit values are only valid for these individual components and may differ from those of the complete system. The data specified for the complete system applies to the complete system in which an individual component is used.

Order number	5ACCIF01.IS00-000
General information	
LEDs	No
B&R ID code	0x2C43
Certifications	
CE	Yes
UKCA	Yes
UL	cULus E115267 Industrial control equipment
Interfaces	
COM	
Quantity	1
Type	RS232, modem supported, not galvanically isolated
Variant	10-pin, male
UART	16550-compatible, 16-byte FIFO buffer
Max. baud rate	115 kbit/s
Electrical properties	
Power consumption	Max. 0.5 W
Operating conditions	
Pollution degree per EN 61131-2	Pollution degree 2
Ambient conditions	
Temperature	
Operation	-20 to 55°C
Storage	-20 to 60°C
Transport	-20 to 60°C
Relative humidity	
Operation	5 to 90%, non-condensing
Storage	5 to 95%, non-condensing
Transport	5 to 95%, non-condensing
Mechanical properties	
Weight	Approx. 25 g

4.2.3.10.3.1 Serial interface COMA - Pinout

Serial interface COMA on the system unit is referred to as "IFx".

Serial interface COMA - IFx ⁽¹⁾⁽²⁾	
RS232	
Variant	10-pin, male
Type	RS232, modem supported
Galvanic isolation	No
UART	16550-compatible, 16-byte FIFO buffer
Transfer rate	Max. 115 kbit/s
Bus length	Max. 15 m
Pin	Pinout
1	DCD
2	DSR
3	RXD
4	RTS
5	TXD
6	CTS
7	DTR
8	RI
9	GND
10	Shield

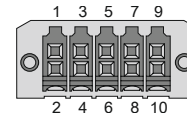

- 1) The interfaces, etc. available on the device or module have been numbered for the purpose of clear differentiation. This numbering may deviate from the numbering used by the respective operating system, however.
- 2) This interface (if available) is automatically enabled in BIOS as COMA with default addresses I/O:3F8h and IRQ:4.

Cable data

For more detailed information about the transfer rate, bus length or cable requirements for the respective interfaces/buses, see "Cable data" on page 180.

4.2.3.10.4 Shielding

For the interfaces on the 10-pin female connector, the shield of the interfaces can be connected to pin *Shield* (pin 2) of the female connector.

In addition, there is a functional ground connection on the interface cover of the system unit and a screw point for cable shields that can also be used for the shielded cables.

4.2.3.10.5 Driver support

Drivers for approved operating systems are available for download in the Downloads section of the B&R website (www.br-automation.com) (if required and not already included in the operating system).

Approved operating systems:

- Linux for B&R
- Windows 10
- Windows Embedded 8.1 Industry
- Windows 7
- Windows Embedded Standard 7

4.2.4 CFast cards

Detailed information about compatible CFast cards is available on the B&R website ([CFast cards](#)).

4.2.5 Front covers

4.2.5.1 5ACFF00.000x-00x

4.2.5.1.1 General information

3 front cover variants are available for APC2100 system units. 3 additional variants are available for APC2100 system units with a 4-port USB hub.

Information:

The front cover is part of the complete system and cannot be ordered as an individual component.

1) If no front cover is selected during standard device configuration, then front cover 5ACFF00.0000-000 (orange APC2100 front cover with B&R logo) is installed and delivered by default.

When configuring a device with a USB hub, 1 of the 3 front covers must be selected (5ACFF00.0001-000, 5ACFF00.0001-001 or 5ACFF00.0001-002).

4.2.5.1.2 Order data

Order number	Short description	Figure
	Front covers	
5ACFF00.0000-000	APC2100 front cover - Orange - With B&R logo	
5ACFF00.0000-001	APC2100 front cover - Dark gray - Without logo	
5ACFF00.0000-002	APC2100 front cover - Orange - Without logo	
5ACFF00.0001-000	APC2100 front cover - Orange - With B&R logo - For USB hub	
5ACFF00.0001-001	APC2100 front cover - Dark gray - Without logo - For USB hub	
5ACFF00.0001-002	APC2100 front cover - Orange - Without logo - For USB hub	

4.2.5.1.3 Technical data

Information:

The following specified characteristic data, features and limit values are only valid for this accessory and may differ from those of the complete system. The data specified for the complete system applies to the complete system in which an accessory is used.

Order number	5ACFF00.0000-000	5ACFF00.0000-001	5ACFF00.0000-002	5ACFF00.0001-000	5ACFF00.0001-001	5ACFF00.0001-002
General information						
Certifications						
CE	Yes					
UKCA	Yes					
UL	cULus E115267 Industrial control equipment					
HazLoc	cULus HazLoc E180196 Industrial control equipment for hazardous locations Class I, Division 2, Groups ABCD, T4					
DNV	Temperature: B (0 to 55°C) Humidity: B (up to 100%) Vibration: A (0.7 g) EMC: B (bridge and open deck)			-		
LR	ENV3			-		
KR	Yes					
ABS	Yes			-		
BV	EC31B Temperature: 5 - 55°C Vibration: 0.7 g EMC: Bridge and open deck			-		
EAC	Product family certification					

Technical data

Order number	5ACCF00. 0000-000	5ACCF00. 0000-001	5ACCF00. 0000-002	5ACCF00. 0001-000	5ACCF00. 0001-001	5ACCF00. 0001-002
Mechanical properties						
Housing						
Front cover	Dyed orange plastic (similar to Pantone 144CV)	Dyed dark gray plastic (similar to Pantone 432C)	Dyed orange plastic (similar to Pantone 144CV)		Dyed dark gray plastic (similar to Pantone 432C)	Dyed orange plastic (similar to Pantone 144CV)
Logo	B&R logo	-		B&R logo	-	
Material	Plastic					
Weight	Approx. 14 g			Approx. 20 g		

5 Installation and wiring

5.1 Basic information

A damaged device has unpredictable properties and states. The unintentional installation or startup of a damaged device must be prevented. The damaged device must be marked as such and made inaccessible, or it must be returned for repairs immediately.

Unpacking

The following activities must be performed before unpacking the device:

- Check the packaging for visible transport damage.
- If transport damage is noticeable, document this immediately and submit a complaint. If possible, have the damage confirmed by the carrier/delivery service.
- Check the contents of the shipment for completeness and damage.
- If the contents of the packaging are incomplete, damaged or do not correspond to the order, the responsible sales office or B&R Headquarters must be informed immediately.
- The information in section "[Protection against electrostatic discharge](#)" on page 11 must be observed for unpacked devices and components.
- Keep the original packaging for further transport.

Power supply

The following information is generally applicable and should be observed before performing any work on the device:

- The entire power supply must be disconnected before removing any covers or components from the device and installing or removing any accessories, hardware or cables.
- Remove the power cable from the device and from the power supply.
- All covers and components, accessories, hardware and cables must be installed or secured before the device is connected to the power supply and switched on.

Caution!

Energy regeneration is not permitted and can cause damage or the device to become defective. Built-in or connected peripheral devices (e.g. USB hubs) are not permitted to introduce any voltage into the device.

Installation

Information:

Optional sets are available that contain all necessary tools for installation. For additional information about tool sets, see section "[Installation accessories](#)" on page 172.

Before installation

The following activities and limitations must be observed before installing the device.

- Allow sufficient space for installation, operation and maintenance of the device.
- The device must be installed on a flat, clean and burr-free surface.
- The wall or control cabinet panel must be able to support four times the total weight of the device. If necessary, bracing must be attached to reinforce the mounting surface.

Caution!

If the load-bearing capacity of the mounting surface is insufficient, or if the fastening material is inadequate or incorrect, the device may fall and become damaged.

- To avoid overheating, the device is not permitted to be placed near other heat sources.

Information about the device's environment

- Observe the notes and regulations regarding the power supply and functional ground.
- Observe the specified bend radius when connecting cables.
- Ventilation openings are not permitted to be covered or blocked.
- The device is only permitted to be operated in closed rooms and not permitted to be exposed to direct sunlight.
- The climatic ambient conditions and environmental conditions must be taken into account – see "Environmental properties" on page 29.

General installation instructions

- Inclined installation reduces the air convection through the device and thus the maximum permissible ambient temperature for operation. If there is sufficient external ventilation in an inclined mounting orientation, the maximum permissible ambient temperature must be checked in each individual case. Failure to do so may result in damage to the equipment and void the certifications and warranty for the device.
- When installing the device, the permissible mounting orientations must be observed - see "Mounting orientations" on page 28.
- When installed in a closed housing, there must be sufficient volume for air circulation - see "Spacing for air circulation" on page 27.
- When connecting installed or connected peripherals, follow the instructions in the peripheral device's documentation.

Transport and storage

Information:

Condensation may form under certain environmental conditions or rapid climatic changes. For improved acclimatization and to avoid damage, the device must be slowly adapted to the room temperature.

When transporting at low temperatures or in the event of large temperature fluctuations, the collection of moisture in or on the device is not permitted. Moisture can cause short circuits in electrical circuits and damage the device.

If a device is transported or stored without packaging, all environmental influences such as shocks, vibrations, pressure and moisture have an unprotected effect on the device. Damaged packaging indicates that the device has been severely affected by environmental influences and may have been damaged.

This can result in malfunctions of the device, machine or system.

Use of third-party products

If third-party devices or components are used, the relevant manufacturer's documentation must be observed. If limitations or interactions by or with third-party products are possible, this must be taken into account in the application.

5.1.1 Installing an Automation PC

The Automation PC 2100 is installed using two M5 screws.

Installation options

The Automation PC 2100 offers two different installation options:

Mounting plate on the back (book style)

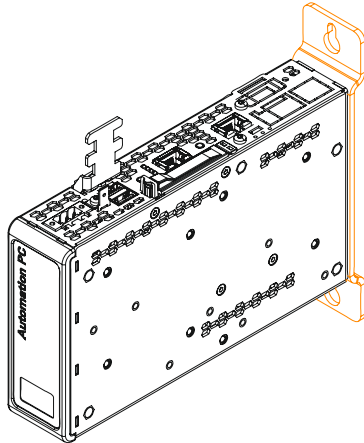

Mounting plate on the right side (box style)

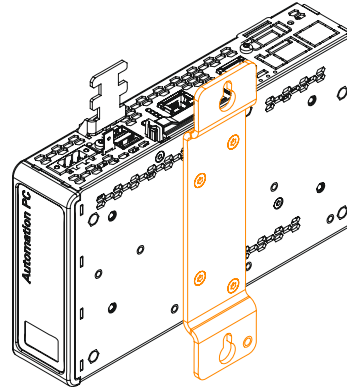

The devices are mounted using the mounting plates provided. The mounting holes are intended for M5 screws.

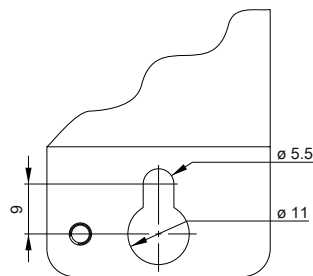

For the exact position of the mounting holes, see section ["Drilling template"](#) on page 26.

Procedure

Preparation

Corresponding M5 screws are not included in delivery and must be selected according to the application; manufacturer's specifications for the max. tightening torque must be observed.

Installation

1. Provide the mounting surface with the necessary holes. For the exact position of the mounting holes, see the drilling templates.
2. Install the B&R industrial PC with M5 screws.

5.1.2 Changing the mounting type (removing/installing the mounting plate)

Before changing the mounting type of the Automation PC, it must be checked as to whether all the specifications in sections "[Mechanical properties](#)" and "[Environmental properties](#)" can still be adhered to.

1. Disconnect the power supply cable to the Automation PC (disconnect the power cable). Disconnect from all sources and poles!
2. Discharge any electrostatic charge on the ground connection.
3. Disconnect all connected cables.
4. Dismount the Automation PC. To do this, remove the M5 screws and take down the Automation PC.
5. Remove the 4 Torx screws (T20) indicated in the following image.

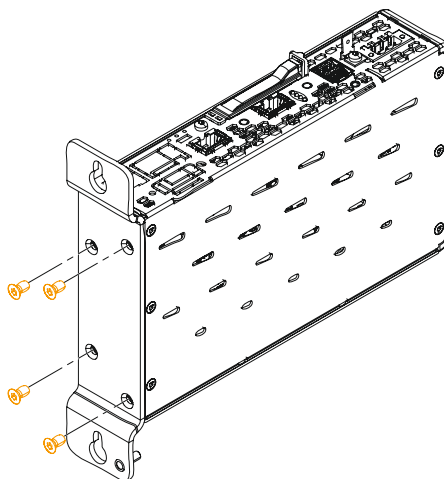
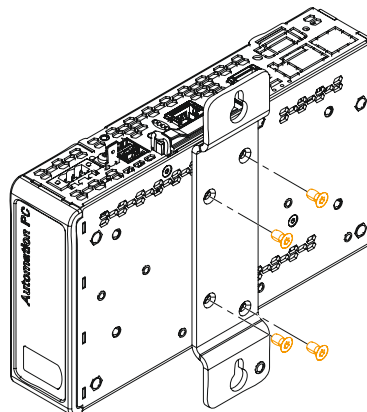

Figure 1: Removing the Torx screws

6. Remove the mounting plate and reattach it to the Automation PC according to the desired mounting type using the Torx screws (T20) loosened earlier (max. tightening torque 0.5 Nm).



7. The Automation PC can now be installed again.

5.1.3 Installing the USB hub

- USB hub 5ACCUSB4.0000-000 can be installed starting with the following revisions of the system units:

System unit	Minimum revision	System unit	Minimum revision
5APC2100.BY01-000	E0	5APC2100.BY11-000	E0
5APC2100.BY22-000	E0	5APC2100.BY34-000	E0
5APC2100.BY44-000	E0	5APC2100.BY48-000	A0

- Front cover 5ACCF00.0001-00x is required to enable correct installation and operation.

1. Screw the 4-port USB hub to the front of the APC2100 using the Torx screw (T10) supplied, tightening torque 0.55 Nm.
The mounting direction of the hub must be taken into account in order to be able to connect the USB cable to the APC2100 later.
2. Front cover 5ACCF00.0001-00x is installed over the USB hub (the figure shows the bottom side of the device).

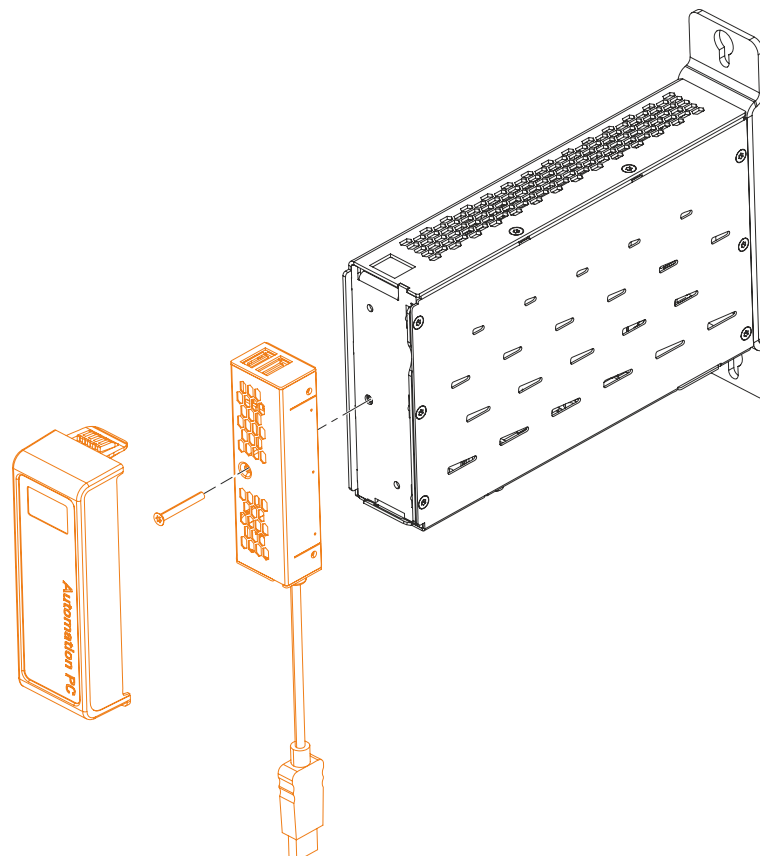

3. Connect the USB cable attached to the USB hub to the USB2 interface of the system unit.

5.2 Connecting to the power grid

Danger!

- The entire power supply must be disconnected and electrostatic discharge must take place on the housing or ground connection before removing any covers or components from the device and installing or removing any accessories, hardware or cables.
- Remove the power cable from the device and from the power supply.
- All covers and components, accessories, hardware and cables must be installed or secured before the device is connected to the power supply and switched on.

5.2.1 Installing the DC power cable

Danger!

The entire power supply to the B&R industrial PC or B&R Automation Panel must be interrupted. Before connecting the DC power cable, it must be checked whether it has been disconnected from the voltage source (e.g. power supply unit).

5.2.1.1 Wiring

Caution!

The pinout of the power supply interface must be observed!

The DC power cable must be implemented with a wire cross section of 0.75 mm² to 1.5 mm² and wire end sleeves.

Conductors of the power cable	Terminal connection symbol
+24 VDC	+
GND	
0 VDC	-

Installing screw clamp terminal block 0TB103.9

Secure the conductors with wire end sleeves ① in the terminal contacts ③ as shown in the figure below and tighten the screw clamp terminals ④ with a screwdriver (max. tightening torque 0.4 Nm). It is important to pay attention to the label on the screw clamp terminal ②.

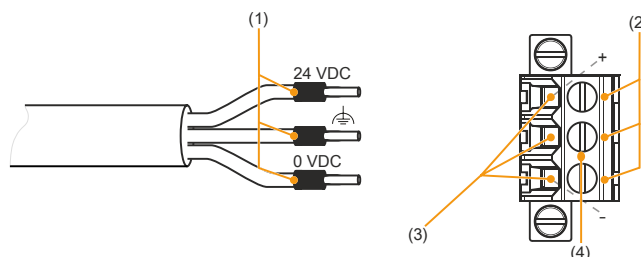

Installing cage clamp terminal block 0TB103.91

Insert a screwdriver into the cage clamp terminals ② and secure the conductors with wire end sleeves ① in the terminal contacts ③ as shown in the figure below. Close the terminal contact by removing the screwdriver. It is important to pay attention to the label on the cage clamp terminal ④.

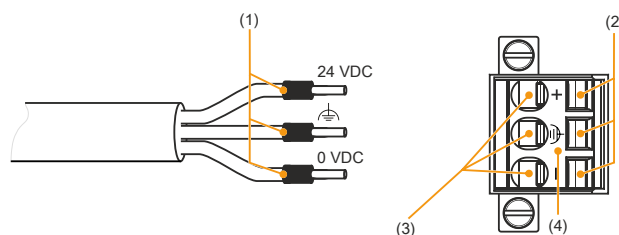

5.2.2 Connecting the power supply to a B&R device

Danger!

The entire power supply to the B&R device must be interrupted. Before connecting the power cable, it must be checked whether it has been disconnected from the voltage source (e.g. power supply unit).

1. Carry out electrostatic discharge on the housing or at the ground connection.
2. Connect the power supply connector to the B&R device and tighten the mounting screws (max. tightening torque 0.5 Nm).

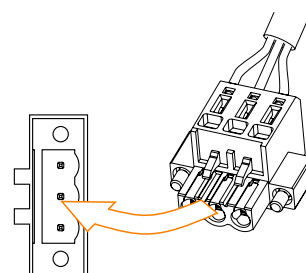

5.2.3 Grounding concept - Functional ground

Functional ground is a low impedance current path between circuits and ground. It is used for equipotential bonding and thus for improving immunity to interference.

Notice!

**Functional grounding does not meet the requirements of protective ground!
Suitable measures for electrical safety in the event of operation and faults must be provided separately.**

The device is equipped with the following functional ground connections:

- Functional ground connection of the power supply
- Ground connection

The functional ground on the B&R device is marked with the following symbol:



The following points must be observed to ensure that electrical interference is safely diverted:

- Connect the device to the central grounding point (e.g. the control cabinet or the system) using the shortest possible low-resistance path.
- Cable design with at least 2.5 mm² per connection. If a cable with wire end sleeve is used with terminal block OTB103.9 or OTB103.91, a cable with a maximum of 1.5 mm² per connection is possible.
- Observe the shielding concept of the conductors. All data cables connected to the device must be implemented using shielded lines.

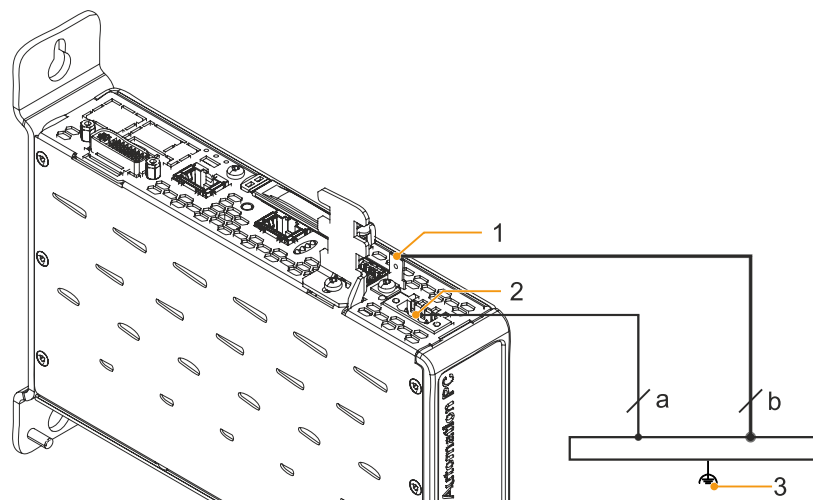

Legend			
1	Ground connection 	2	Power supply connection +24 VDC pin 2
a	At least 1.5 mm ²	b	At least 2.5 mm ²
		3	Central grounding point
			-

5.3 Connecting cables

When connecting or installing cables, the bend radius specification must be observed. For this specification, see the technical data of the respective cable.

The maximum tightening torque of the locating screws is 0.5 Nm.

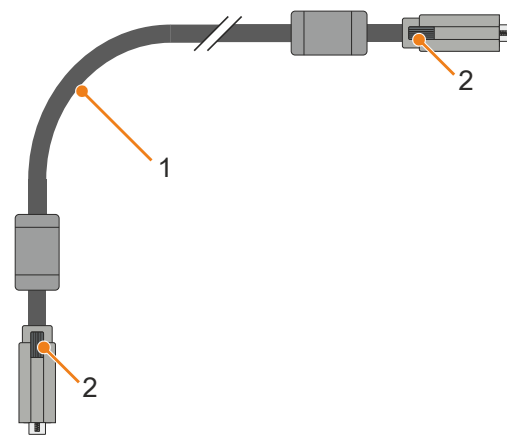

- 1) Bend radius
- 2) Locating screws

6 Commissioning

6.1 Basic information

Information:

Condensation may form under certain environmental conditions or rapid climatic changes. For improved acclimatization and to avoid damage, the device must be slowly adapted to the room temperature.

6.2 Switching on the device for the first time

6.2.1 General information before switching on the device

Checklist

Before the device is started up for the first time, the following points must be checked:

- Have the installation instructions been observed as described in "[Installation and wiring](#)" on page 89?
- Have the permissible ambient conditions and environmental conditions for the device been taken into account?
- Is the power supply connected correctly and have the values been checked?
- Is the ground cable correctly connected to the ground connection?
- Before installing additional hardware, the device must have been started up.

Caution!

Before the device is started up, it must be gradually adapted to room temperature! Exposure to direct heat radiation is not permitted.

When transporting at low temperatures or in the event of large temperature fluctuations, the collection of moisture in or on the device is not permitted.

Moisture can cause short circuits in electrical circuits and damage the device.

Requirements

The following criteria must be met before switching on the device for the first time:

- The functional ground connections are as short as possible and connected to the central grounding point using the largest possible wire cross section.
- All connection cables are connected correctly.
- A USB keyboard and USB mouse are connected (optional).

6.2.2 Switching on the device

Procedure

1. Connect the power supply and switch it on (e.g. power supply unit).
2. The device is operating and boots; LED *Power* lights up.

6.3 General instructions about the procedure for temperature testing

The purpose of these instructions is to explain the general procedure for application-specific temperature tests with B&R industrial PCs or Power Panels. These instructions are only guidelines, however.

6.3.1 Procedure

In order to obtain meaningful results, the test conditions should correspond to conditions in the field. This means that during the temperature tests, for example, the target application should be running and the PC should be installed in the control cabinet housing that will be used later.

In addition, a temperature sensor should be installed for the device being tested in order to continuously monitor the ambient temperature. To obtain correct values, it must be installed at a distance of approx. 5 to 10 cm from the B&R industrial PC near the air inlet (not near the air outlet).

Every B&R industrial PC or Power Panel is equipped with internal temperature sensors. Depending on the device family, these are installed in different positions. The number and temperature limits vary depending on the device family.

For position specifications of the temperature sensors and their maximum specified temperatures, see section "Temperature sensor positions" on page 32.

A minimum test time of 8 hours is recommended for to optimally determine and assess the temperature situation.

6.3.2 Evaluating temperatures in Windows operating systems

6.3.2.1 Evaluating with the ADI Control Center

The *ADI Control Center* can be used to evaluate temperatures. The temperatures can be viewed in tab **Temperatures**. The ADI Control Center can be downloaded from the B&R website (www.br-automation.com) at no cost and uses the ADI (Automation Device Interface).

The following figure shows an APC2100 in the ADI Control Center.

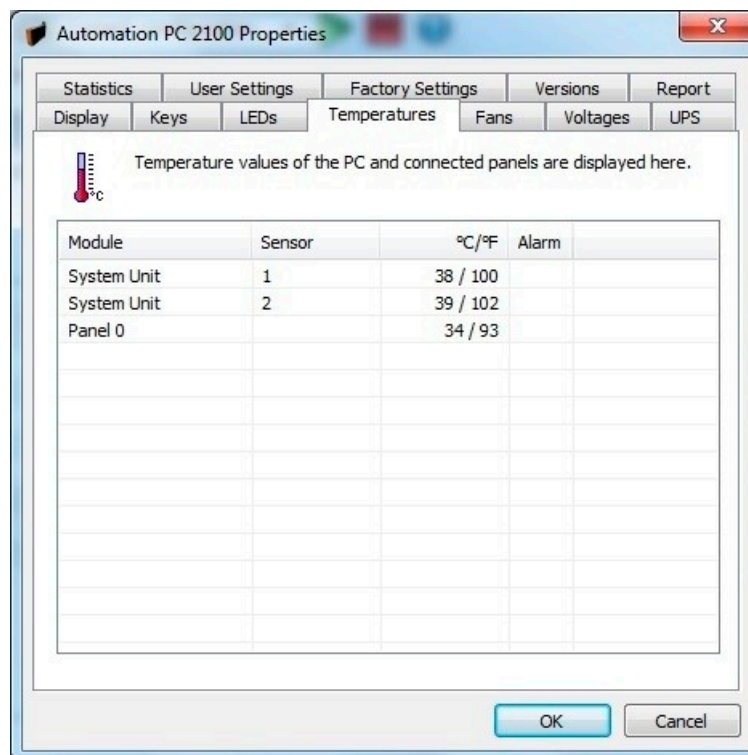

If historical recording of the data is necessary, a separate application can be created.

Information:

To create a separate application, downloads such as the ADI .NET SDK are available on the B&R website (www.br-automation.com).

6.3.2.2 Evaluating with the BurnInTest tool from PassMark

If a separate application is not created or used for temperature evaluation, B&R recommends using the BurnInTest software tool from PassMark.

The BurnInTest software tool is available in standard and professional versions. In addition to the software package, various loopback adapters (serial, parallel, USB, etc.) and test CDs or DVDs are also available. Depending on the expansion level of the software and available loopback adapters, a correspondingly high system and peripheral load can be generated.

Information:

Loopback adapters are also available from PassMark. For additional information, see www.pass-mark.com.

The following screenshots are based on PassMark BurnInTest Pro V6 using an APC2100 without IF options.

Settings¹⁾:

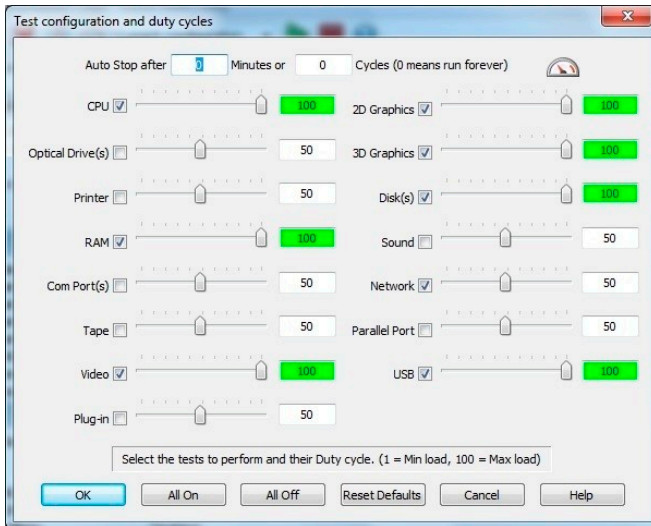

Test overview¹⁾:

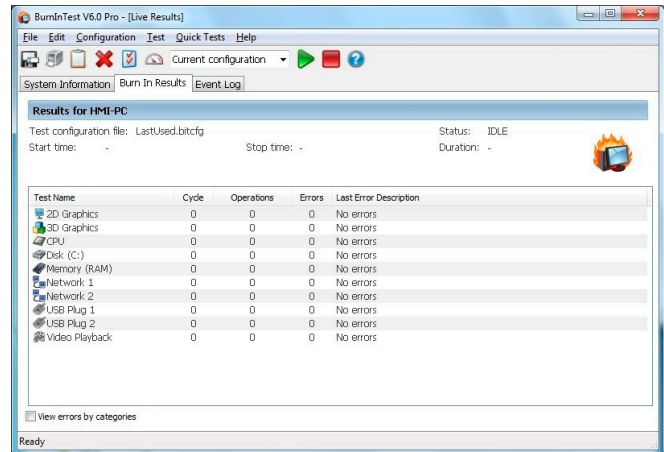

Figure 2: Test overview of an APC2100 without IF options

1) Symbolic image.

Test properties may need to be fine-tuned depending on the availability of loopback adapters and DVDs.

If no USB loopback adapters are available, USB flash drives can also be used. These must be available in Windows as formatted drives. Option **USB** must be deselected under **Test selection and duty cycles**, and **Test this device** must then be selected in the **Disk** settings (**Configuration / Test Preferences / Disk**).



Serial loopback adapters can be easily created by connecting some pins as shown.

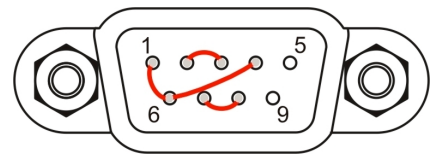

6.3.3 Evaluating the measurement results

The recorded maximum temperature value of each individual sensor is not permitted to exceed the temperature limit specified in the user's manuals.

If the temperature tests cannot be carried out in a climate chamber, they can be carried out in an office environment, for example. It is necessary to record the ambient temperature, however. Based on experience gained at B&R, the measured temperature values can be extrapolated linearly to the ambient temperature for passive systems (systems without a fan kit). In order to also be able to extrapolate the temperature values for systems with a fan kit, the fans must be running. The speed, etc. must also be taken into account.

If the temperature tests are carried out in a controlled climate chamber with a fan, the devices to be tested are cooled by this fan and thus the measurement results are distorted. With passive devices, the measurement results are therefore unusable. In order to be able to carry out temperature tests in climate chambers with fans without distorting the measurement results, however, the fan of the climate chamber must be switched off and a correspondingly long lead time (several hours) must be observed.

6.4 Known problems / Characteristics

- CAN IF option 5ACCIF01.ICAN-000 is supported in Windows 7 and later by PVI V4.2.5 or Windows CAN driver V3.0.
- The USB 2.0 transfer rate is limited to 30 Mbit/s with SDL3.
- A display is always emulated by the SDL3 transmitter using EDID data and hot plug detection, so DVI-compatible operation is possible. For this reason, faulty representations may occur during operation with multiple displays. This can occur under the following circumstances:
 - No cable is connected.
 - There is no connection established yet between the SDL3 link module and SDL3 receiver.

It is possible to get around these incorrect graphic representations by making suitable settings to BIOS or the graphics driver.

- If problems occur with the ETH1 or ETH2 interface (connection abort, slow data transfer, etc.), the Energy-Efficient Ethernet feature can be disabled in the driver as a possible solution.
- If USB 3.0 should be used, the XHCI mode must be configured as follows for the operating systems mentioned:
 - Windows 10 or Windows 8.1 set to "Enabled"
 - Windows 7 set to "Smart auto"

If XHCI mode is set to "Smart auto" in Windows 8.1 or Windows 10, then only USB 2.0 is supported. The default value for setting "XHCI mode" is "Smart auto".

- If problems occur during shutdown or rebooting in Linux for B&R, the USB 3.0 function can be disabled as a possible workaround. To do this, the XHCI controller must be set to "Disabled" in the BIOS USB configuration.
- In order to slightly improve the real-time behavior (jitter) of Automation Runtime Windows (ARwin) or Automation Runtime Embedded (AREmb) in graphics-intensive applications, set BIOS setting *Advanced - Graphics (IGD) configuration - IGD turbo* to *Disabled*. If BIOS setting *Advanced - Graphics (IGD) configuration - IGD turbo* is set to *Disabled*, the graphics performance of the system is noticeably reduced.
- MTCX version 1.25 or higher must be used starting with the following revisions. New devices are delivered with the corresponding MTCX version.

Order number	Rev.	Order number	Rev.	Order number	Rev.
5APC2100.BY01-000	N0	5APC2100.BY22-000	N0	5APC2100.BY44-000	N0
5APC2100.BY11-000	M0	5APC2100.BY34-000	N0	5APC2100.BY48-000	J0

If an MTCX version less than 1.25 is used on a device with the previously mentioned revisions, the system unit does not provide correct temperature values from [system unit sensors 1 and 2](#).

Projects in Automation Studio must be updated with the following HWX upgrades or higher:

Order number	HWX	Order number	HWX	Order number	HWX
5APC2100.BY01-000	V1.4.2.0	5APC2100.BY22-000	V2.1.2.0	5APC2100.BY44-000	V2.1.2.0
5APC2100.BY11-000	V1.4.2.0	5APC2100.BY34-000	V2.1.2.0	5APC2100.BY48-000	V2.1.2.0

7 Software

7.1 BIOS options

Information:

The following figures, BIOS menu options and descriptions refer to BIOS version 1.44. It is therefore possible that these diagrams and BIOS descriptions will not correspond with the BIOS version actually installed. In addition, the BIOS menu options provided depend on the system configuration.

7.1.1 General information

BIOS is the abbreviation for "Basic Input and Output System". It is the basic standardized connection between user and system (hardware). This B&R industrial PC uses BIOS from Phoenix.

The BIOS Setup Utility allows you to modify basic system configuration settings. These settings are stored in the CMOS and EEPROM (as backup).

CMOS data is nonvolatile and remains stored on the B&R industrial PC for a certain amount of time even when the power is switched off (no 24 VDC power supply). For more information, see the technical data of the system unit.

Information:

The following BIOS settings are system-optimized. Changes should only be made by experts who have knowledge of their effects.

7.1.2 BIOS Setup and start procedure

BIOS is enabled immediately after switching on the power supply of the B&R industrial PC or pressing the power button. A check takes place as to whether the setup data from the EEPROM is "OK". If "OK", the data is transferred to the CMOS. If "not OK", the CMOS data is checked for validity. If the CMOS data is also invalid, an error message is output and the boot procedure can be resumed without problems by pressing the <F1> key. To prevent an error message from appearing on each restart, launch the BIOS Setup utility by pressing <F2> and resave the settings.

BIOS reads the system configuration information, checks the system and configures it through the power-on self-test (POST).

When these "preparations" are completed, BIOS searches the system for an operating system in the available data storage devices (hard disk drive, floppy disk drive, etc.). BIOS starts the operating system and transfers to it control over system operations.

To enter BIOS Setup, the "F2" key must be pressed after the USB controller has been initialized as soon as the following message appears on the monitor (during POST): "F2 = Setup"

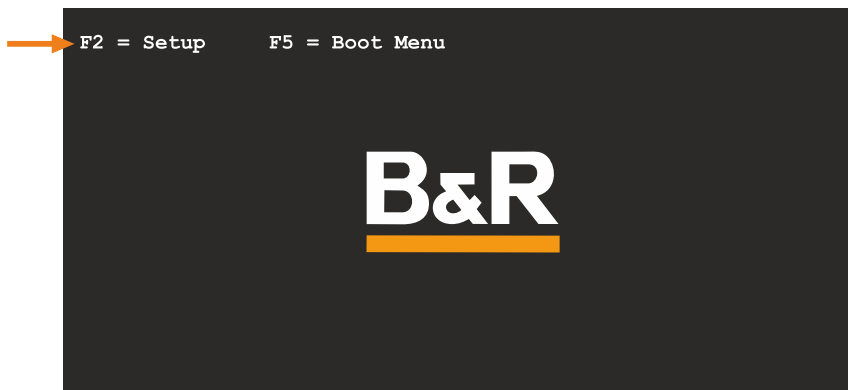

7.1.3 BIOS default settings

Setting options marked in bold represent the default value.

If function "Load setup defaults" is selected in the BIOS Setup main menu, or if "Exit" is selected (or F9 is pressed) in the individual setup screens, the default values are the optimized values that will be used.

7.1.4 BIOS Setup buttons

The following keys are enabled during POST:

Information:

The key signals of the USB keyboard are only accepted after initializing the USB controller.

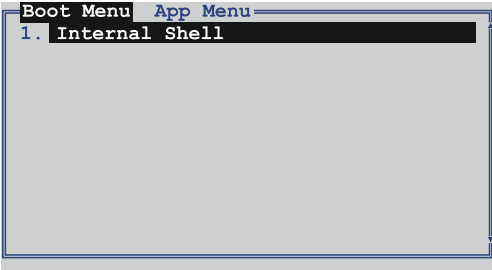
Keys	Function
F2	Access to the BIOS Setup menu.
F5	Opens the boot menu. This lists all bootable devices that are connected to the system. Selecting a device with cursor ↑, cursor ↓ and then pressing <ENTER> will boot from that device.
	
<Pause>	The POST can be stopped with the <Pause> button. After pressing any other key, the POST continues to run.

The following keys can be used after entering BIOS Setup:

Key	Function
F1	General help.
Cursor ↑	Go to previous object.
Cursor ↓	Go to next object.
Cursor ←	Go to previous object.
Cursor →	Go to next object.
+/-	Changes the setting of the selected function.
Enter	Switches to the selected menu.
Page ↑	Jumps to the first BIOS menu option or object.
Page ↓	Jumps to the last BIOS menu option or object.
Home	Jumps to the first BIOS menu option or object.
End	Jumps to the last BIOS menu option or object.
F7	Resets the changes.
F9	Loads and sets CMOS default values for all BIOS settings.
F10	Saves and closes.
Esc	Exits the submenu.

7.1.5 Main

The BIOS Setup main menu appears immediately after the F2 button is pressed during system startup.

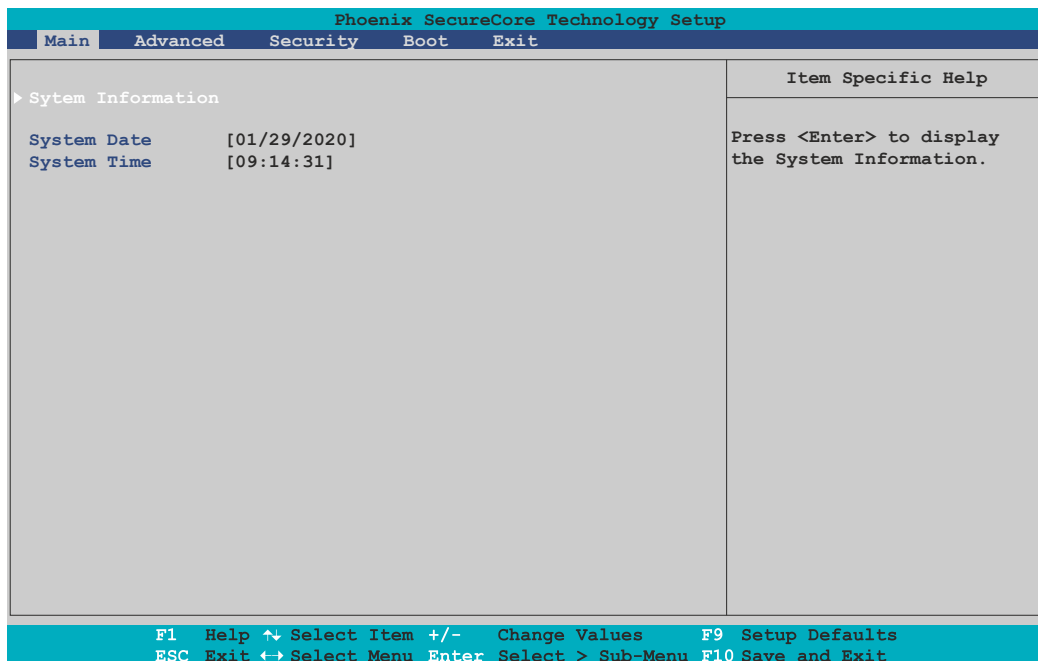

BIOS setting	Explanation	Configuration options	Effect
System information	Displays information about the chipset, CPU board and main memory.	Enter	Opens this submenu See " System information " on page 103.
System date	The currently configured system date. Buffered after the system is switched off. For details, see technical data of the system unit.	Change the system date	Sets the system date in the format Month:Day:Year (mm:dd:yyyy).
System time	The currently configured system time setting. Buffered after the system is switched off. For details, see technical data of the system unit.	Change the system time	Sets the system time in the format Hour:Minute:Second (hh:mm:ss).

7.1.5.1 System information

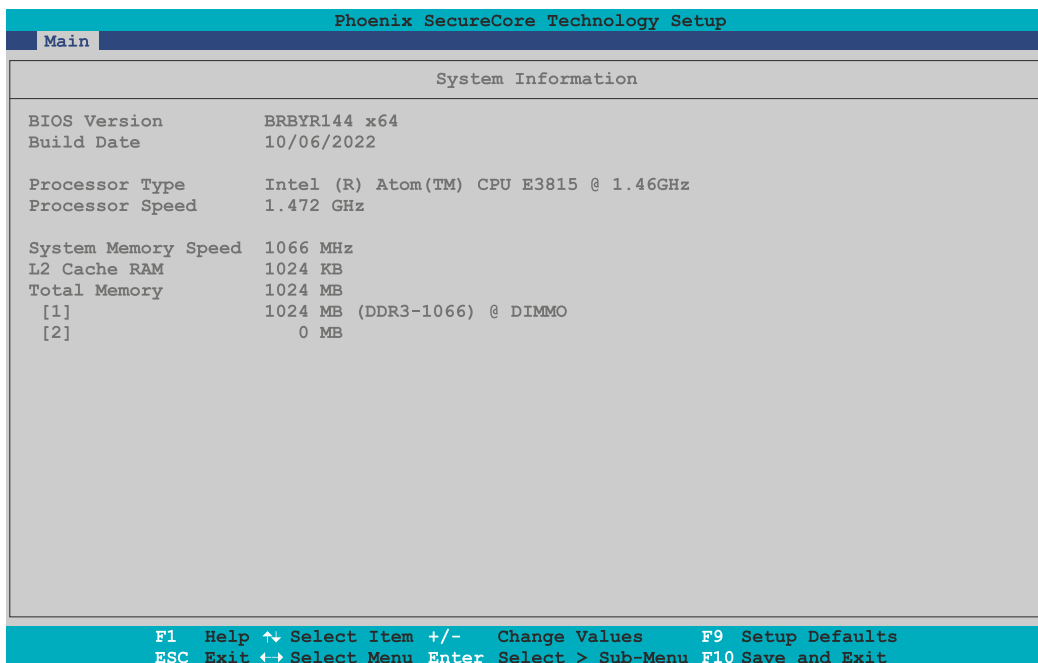

BIOS setting	Explanation	Configuration options	Effect
BIOS version	Displays the BIOS version.	None	-
Build time	Displays the date the BIOS was created.	None	-
Processor type	Displays the processor type.	None	-
Processor speed	Displays the processor frequency.	None	-
System memory speed	Displays the main memory frequency.	None	-

BIOS setting	Explanation	Configuration options	Effect
L2 cache RAM	Displays the L2 cache size.	None	-
Total memory	Displays the total main memory size.	None	-
[1]	Displays the main memory size in slot 1.	None	-
[2]	Displays the main memory size in slot 2.	None	-

7.1.6 Advanced

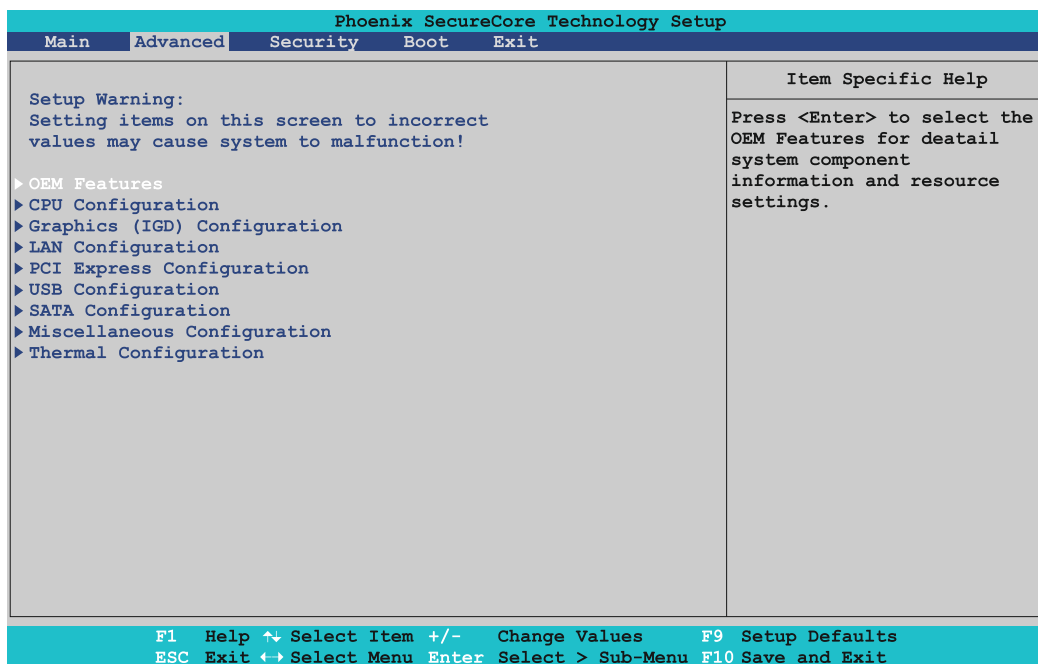

BIOS setting	Explanation	Configuration options	Effect
OEM features	Configures OEM features.	Enter	Opens this submenu See "OEM features" on page 105.
CPU configuration	Configures CPU settings.	Enter	Opens this submenu See "CPU configuration" on page 112.
Graphics (IGD) configuration	Graphics settings configuration.	Enter	Opens this submenu See "Graphics (IGD) configuration" on page 114.
LAN configuration	Configures LAN settings.	Enter	Opens this submenu See "LAN" on page 116.
PCI express configuration	Configures PCI Express settings.	Enter	Opens this submenu See "PCI express configuration" on page 117.
USB configuration	Configures USB settings.	Enter	Opens this submenu See "USB configuration" on page 119.
SATA configuration	Configures SATA settings.	Enter	Opens this submenu See "SATA configuration" on page 120.
Miscellaneous configuration	Configures miscellaneous settings.	Enter	Opens this submenu See "Miscellaneous configuration" on page 120.
Thermal configuration	Configures temperature settings.	Enter	Opens this submenu See "Thermal configuration" on page 121.

7.1.6.1 OEM features

Phoenix SecureCore Technology Setup		
Advanced		
OEM Features		Item Specific Help
Version Information		Press <Enter> to select the Display Board Features for detail system component information and resource
Main BIOS Version	BRBYR144	
OEM BIOS Version		
MTCX FW Version	1.25	
ETH1 MAC Address	00:E0:4B:4C:A5:D8	
ETH2 MAC Address	00:E0:4B:4C:A5:D9	
OEM String		
Bernecker + Rainer Industrie-Elektronik T1.44		
▶ Miscellaneous Configuration		
▶ Super I/O Configuration		
▶ System Board Features		
▶ Display Link Features		
▶ IF Board Features		
F1 Help ↕ Select Item +/- Change Values F9 Setup Defaults ESC Exit ← Select Menu Enter Select > Sub-Menu F10 Save and Exit		

BIOS setting	Explanation	Configuration options	Effect
Version information		None	-
Main BIOS version	Displays the installed B&R BIOS version.	None	-
OEM BIOS version		None	-
MTCX firmware version	Displays the installed MTCX version.	None	-
ETH1 MAC address	Displays the assigned MAC address for the ETH1 interface.	None	-
ETH2 MAC address	Displays the assigned MAC address for the ETH2 interface.	None	-
OEM string	Displays the OEM string.	None	-
Miscellaneous configuration	Configures miscellaneous settings.	Enter	Opens this submenu See "Miscellaneous configuration" on page 106.
Super I/O configuration	Configures special interface settings.	Enter	Opens this submenu See "Super I/O configuration" on page 106.
System board features	Displays device-specific information for the system unit.	Enter	Opens this submenu See "System board features" on page 107.
Display link features	Displays device-specific information for the connected display	Enter	Opens this submenu See "Display link features" on page 109.
IF board features	Displays device-specific information for the IF option.	Enter	Opens this submenu See "IF board features" on page 111.

7.1.6.1.1 Miscellaneous configuration

Phoenix SecureCore Technology Setup

Advanced

Miscellaneous Configuration	Item Specific Help
After Power loss [Power On] Test Interface [Disabled]	Affects the following settings: DTS disabled P-States/C-States disabled Turbo Boost disabled RP 1 ASPM disabled. The respective setup items will be ignored

F1 Help ↕ Select Item +/- Change Values F9 Setup Defaults
 ESC Exit ↔ Select Menu Enter Select > Sub-Menu F10 Save and Exit

BIOS setting	Explanation	Configuration options	Effect
After power loss	Option for setting the behavior after a power loss.	Stay off	The PC remains switched off during a power on.
		Power on	The PC is restarted during a power on.
Test interface		None	-

7.1.6.1.2 Super I/O configuration

Phoenix SecureCore Technology Setup

Advanced

Super I/O Configuration	Item Specific Help
Serial Port A [Default] Base Address [3F8] IRQ [4] Serial Port C [Default] Base Address [3E8] IRQ [11] CAN [Default] Base Address [384] IRQ [10]	Enable/Disable Serial Port. Disabled: Disable Port. Manual: Set Port values manual Default: Use system default values.

F1 Help ↕ Select Item +/- Change Values F9 Setup Defaults
 ESC Exit ↔ Select Menu Enter Select > Sub-Menu F10 Save and Exit

BIOS setting	Explanation	Configuration options	Effect
Serial port A	Setting for the COM interface on the IF option.	Disabled	Disables this interface.
		Manual	Allows manual settings for "Base address" and "IRQ".
		Default	Uses the default settings.
Base address	Sets and displays the I/O address.	3F8h	Default setting
		Any	Allows any I/O address to be entered.
IRQ	Sets and displays the IRQ.	3, 4, 5, 6, 7, 10, 11, 12, 14, 15	Manual assignment.
Serial port C	SDL or SDL3 Link setting for the resistive touch screen	Disabled	Disables this interface.
		Manual	Allows manual settings for "Base address" and "IRQ".
		Default	Uses the default settings.
Base address	Sets and displays the I/O address.	3E8h	Default setting
		Any	Allows any I/O address to be entered.

BIOS setting	Explanation	Configuration options	Effect
IRQ	Sets and displays the IRQ.	3, 4, 5, 6, 7, 10, 11, 12, 14, 15	Manual assignment.
CAN	Setting for the CAN interface on the IF option.	Default	Uses the default settings. No other settings are possible.
Base address	Displays the I/O address.	384h/385h	Permanently assigned. This setting cannot be modified.
IRQ	Displays IRQ.	10	Permanently assigned. This setting cannot be modified.

7.1.6.1.3 System board features

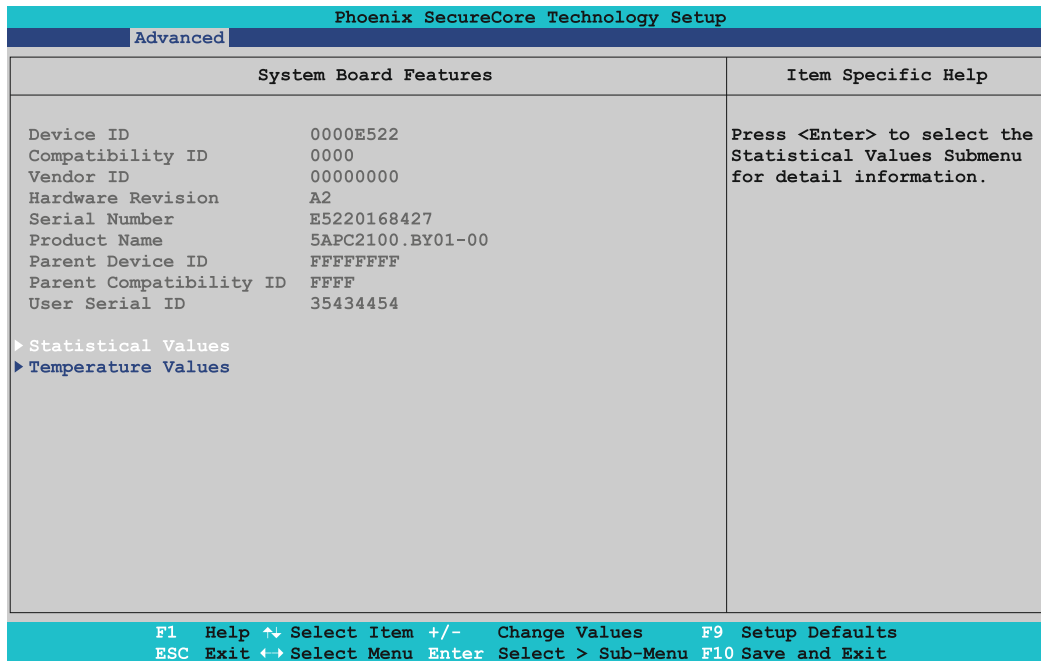

BIOS setting	Explanation	Configuration options	Effect
Device ID	Displays the device ID of the system unit.	None	-
Compatibility ID	Displays the version of the device within the same B&R device ID. This ID is required for Automation Runtime.	None	-
Vendor ID	Displays the manufacturer ID.	None	-
Hardware revision	Displays the hardware revision of the system unit.	None	-
Serial number	Displays the B&R serial number.	None	-
Product name	Displays the B&R model number.	None	-
Parent device ID	Displays the manufacturer number.	None	-
Parent Compatibility ID	Displays the manufacturer ID.	None	-
User serial ID	Displays the user serial ID. This 8-digit hex value is freely available to the user (e.g. to allow the device to be uniquely identified) and can only be changed with the B&R Control Center provided by B&R via the ADI driver.	None	-
Statistical values	Displays the statistical values.	Enter	Opens this submenu See "Statistical values" on page 108.
Temperature Values	Displays current temperature values.	Enter	Opens this submenu See "Temperature values" on page 108.

7.1.6.1.3.1 Statistical values

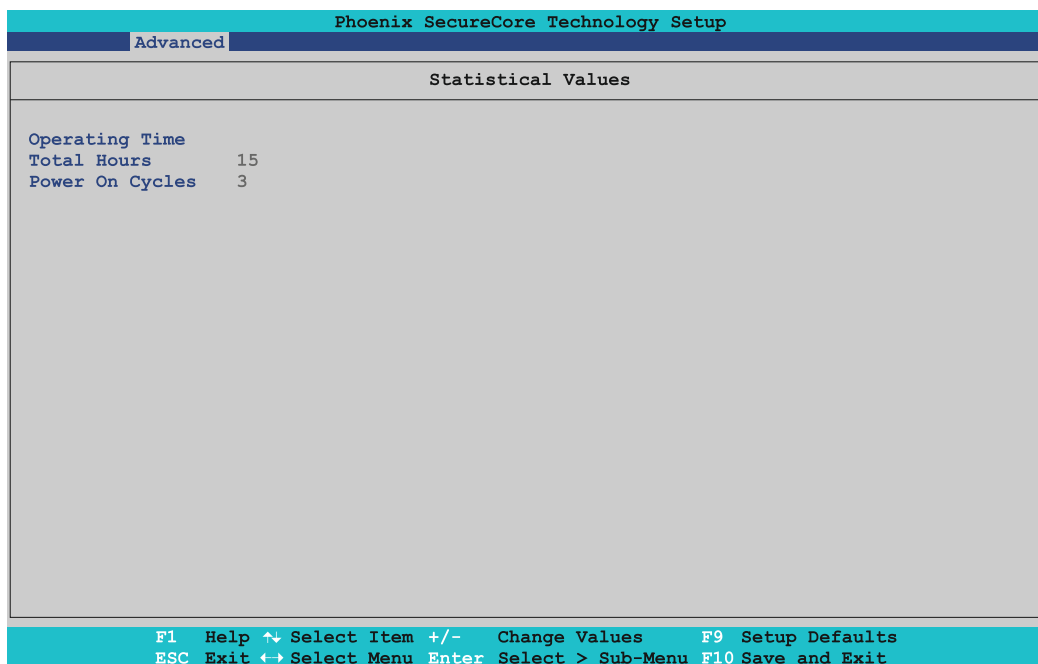

BIOS setting	Explanation	Configuration options	Effect
Total hours	Displays the runtime in hours.	None	-
Power on cycles	Displays the power on cycles - Each restart increases the counter by one.	None	-

7.1.6.1.3.2 Temperature values

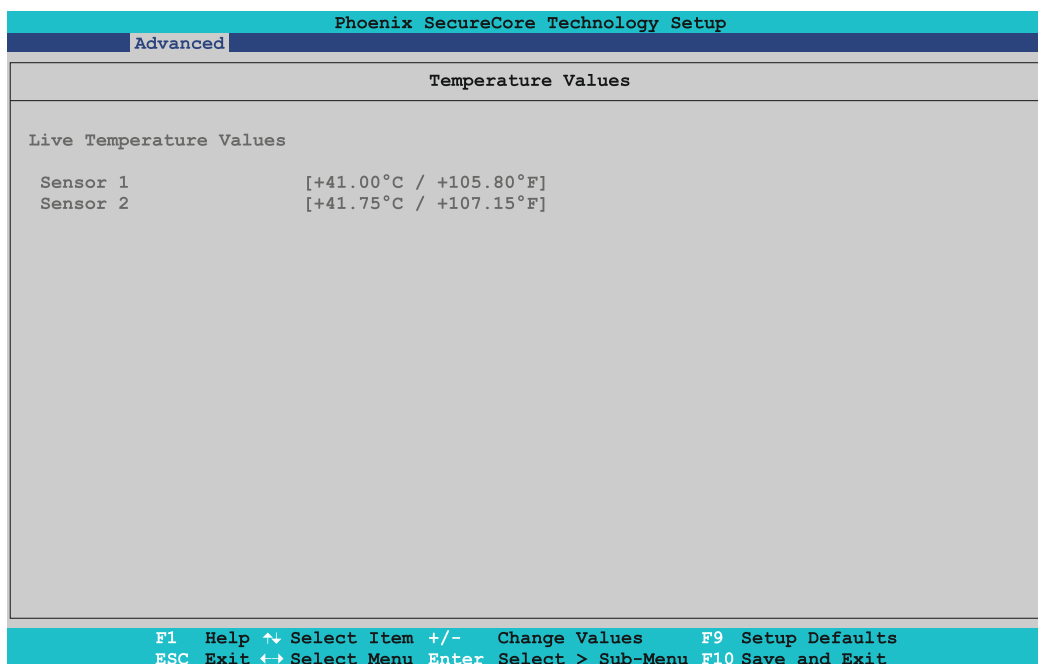

BIOS setting	Explanation	Configuration options	Effect
Sensor 1	Displays the current temperature of sensor 1 (system unit sensor 2) in °C and °F (sensor close to the RAM).	None	-
Sensor 2	Displays the current temperature of sensor 2 (system unit sensor 1) in °C and °F (sensor near the CPU).	None	-

7.1.6.1.4 Display link features

Phoenix SecureCore Technology Setup

Main **Advanced**

Display Link Features	Item Specific Help
Device ID 0000E5BF Compatibility ID 0000 Vendor ID 00000000 Hardware Revision A0 Serial Number E5BF01000000 Product Name 5ACCLI01.SDL0-00 Firmware Version 00.05 Parent Device ID FFFFFFFF Parent Compatibility ID FFFF ▶ Statistical Values ▶ Panel #0	Press <Enter> to select the Statistical Values Submenu for detail information.

F1 Help ↕ Select Item +/- Change Values F9 Setup Defaults
 ESC Exit ← Select Menu Enter Select > Sub Menu F10 Save and Exit

BIOS setting	Explanation	Configuration options	Effect
Device ID	Displays the device ID of the connected display unit	None	-
Compatibility ID	Displays the version of the device within the same B&R device ID. This ID is needed for Automation Runtime.	None	-
Vendor ID	Displays the vendor ID.	None	-
Hardware revision	Displays the hardware revision of the display unit	None	-
Serial number	Displays the B&R serial number.	None	-
Product name	Displays the B&R model number.	None	-
Firmware version	Displays the firmware version	None	-
Parent device ID	Displays the manufacturer number.	None	-
Parent compatibility ID	Displays the manufacturer ID.	None	-
Statistical values	Displays statistical values.	Enter	Opens this submenu See "Statistical values" on page 110.
Panel #X	Displays the panel properties of the display unit	Enter	Opens this submenu See "Panel #x" on page 110.

7.1.6.1.4.1 Statistical values

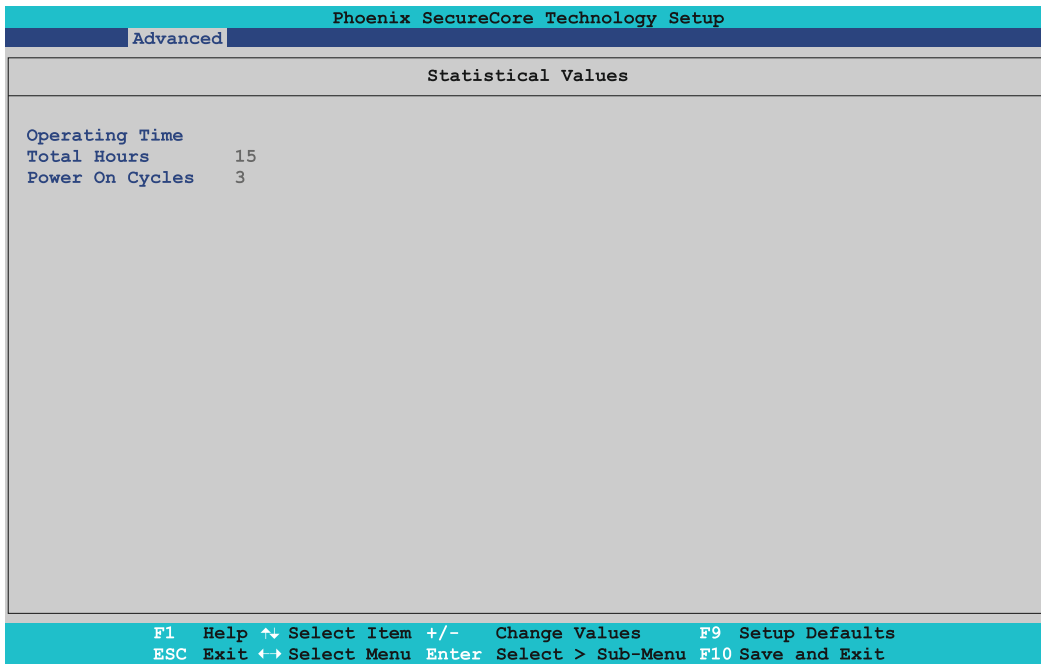

BIOS setting	Explanation	Configuration options	Effect
Total hours	Displays the runtime in hours.	None	-
Power on cycles	Displays the number of power cycles. Each restart increases the counter by one.	None	-

7.1.6.1.4.2 Panel #x

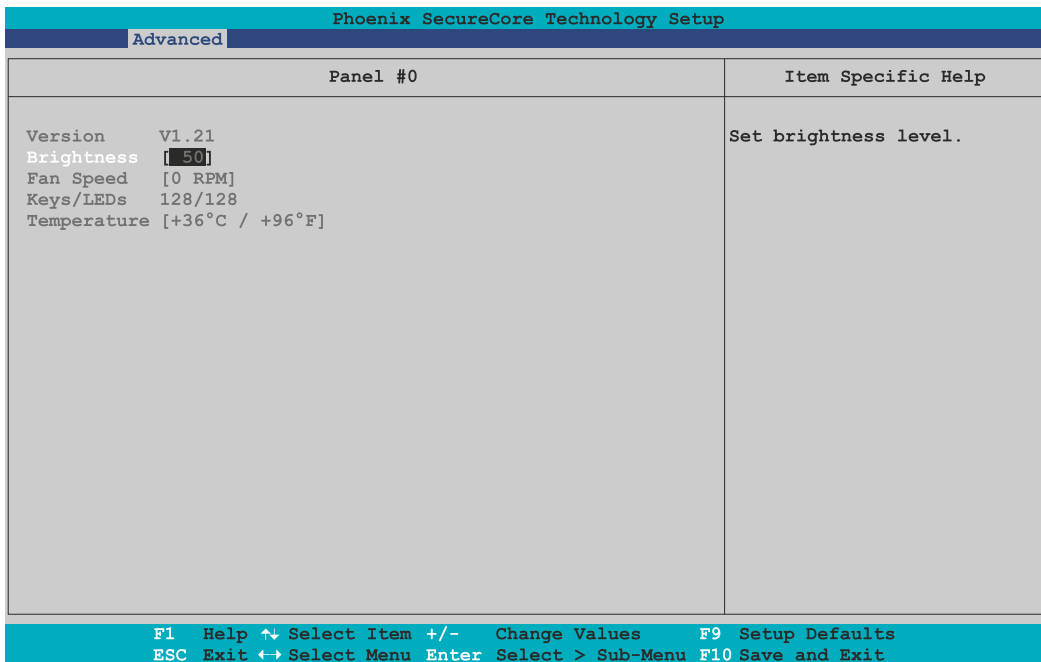

BIOS setting	Explanation	Configuration options	Effect
Version	Displays the panel firmware version.	None	-
Brightness	Sets the display brightness.	0 to 100	Sets the brightness (in %) of the selected panel. Settings take effect immediately.
Fan speed	Displays the fan speed of the display unit	None	-
Keys/LEDs	Displays the available keys and LEDs for the display unit	None	-
Temperature	Displays the temperature of the display unit in °C and °F	None	-

7.1.6.1.5 IF board features

Phoenix SecureCore Technology Setup

Advanced

IF Board Features	Item Specific Help
Device ID 0000E53F Compatibility ID 0000 Vendor ID 00000000 Hardware Revision A0 Serial Number E53F0168528 Product Name 5ACCIF01.FPSC-000 Parent Device ID FFFFFFFF Parent Compatibility ID FFFF ▶ Statistical Values	Press <Enter> to select the Statistical Values Submenu for detail information.

F1 Help ↕ Select Item +/- Change Values F9 Setup Defaults
 ESC Exit ↔ Select Menu Enter Select > Sub-Menu F10 Save and Exit

BIOS setting	Explanation	Configuration options	Effect
Device ID	Displays the device ID of IF option.	None	-
Compatibility ID	Displays the version of the device within the same B&R device ID. This ID is required for Automation Runtime.	None	-
Vendor ID	Displays the manufacturer ID.	None	-
Hardware revision	Displays the hardware revision of the IF option.	None	-
Serial number	Displays the B&R serial number.	None	-
Product name	Displays the B&R model number.	None	-
Parent device ID	Displays the manufacturer number.	None	-
Parent Compatibility ID	Displays the manufacturer ID.	None	-
Statistical values	Displays the statistical values.	Enter	Opens this submenu See "Statistical values" on page 111.

7.1.6.1.5.1 Statistical values

Phoenix SecureCore Technology Setup

Advanced

Statistical Values
Operating Time Total Hours 15 Power On Cycles 3

F1 Help ↕ Select Item +/- Change Values F9 Setup Defaults
 ESC Exit ↔ Select Menu Enter Select > Sub-Menu F10 Save and Exit

BIOS setting	Explanation	Configuration options	Effect
Total hours	Displays the runtime in hours.	None	-
Power on cycles	Displays the power on cycles - Each restart increases the counter by one.	None	-

7.1.6.2 CPU configuration

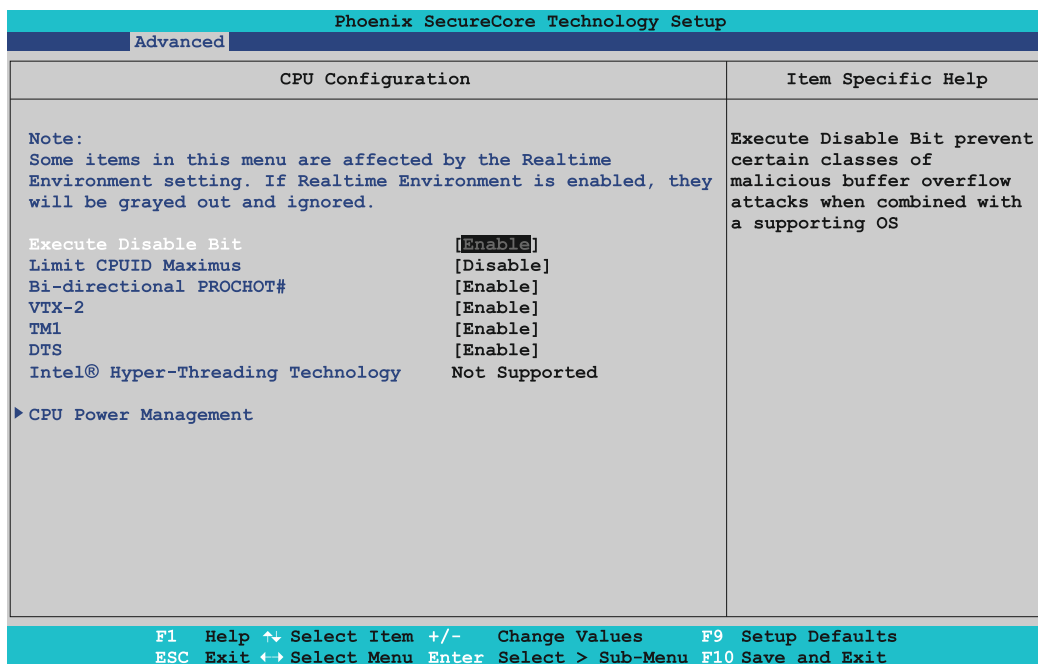

BIOS setting	Explanation	Configuration options	Effect
Execute disable bit	Option for enabling/disabling hardware support for prevention of data execution.	Disabled	Disables this function.
		Enabled	Enables this function.
Limit CPUID maximum	Option for limiting the CPU ID value. This may be necessary for older operating systems that do not support CPUID functions.	Disabled	The processor returns the current maximum value when the CPU ID value is requested.
		Enabled	If necessary, the processor limits the maximum CPU ID value to 03h if the processor supports a higher value.
Bi-directional PROCHOT# ¹⁾	Option for enabling/disabling the PROCHOT signal. The PROCHOT signal initializes temperature throttling so that the CPU can be slowed down and protected against overheating.	Disabled	Disables this function. Only the processor cores can enable the PROCHOT signal and throttle the processor.
		Enabled	Enables this function. External services can enable the PROCHOT signal and choke the processor.
VTX-2	Option for enabling/disabling a virtual machine.	Disabled	Disables this function.
	<p>Information:</p> <p>A restart is required in order to apply changes made to this setting.</p>	Enabled	If this function is enabled, a virtual machine can use the additional hardware capacity.
TM1	Option for setting the temperature monitoring.	Disabled	The temperature monitoring is disabled.
		Enabled	Intel thermal mode 1 is enabled. If the CPU temperature is too high, the processor speed is reduced by 50%.
DTS	Option for enabling/disabling the CPU digital thermal sensor function.	Disabled	Disables this function.
		Enabled	Enables this function.
Intel Hyper-Threading Technology	Displays whether Intel Hyper-Threading Technology is supported.	None	-
CPU power management	Configures CPU energy settings.	Enter	Opens this submenu See "CPU power management" on page 113.

1) PROCHOT = Processor Hot

7.1.6.2.1 CPU power management

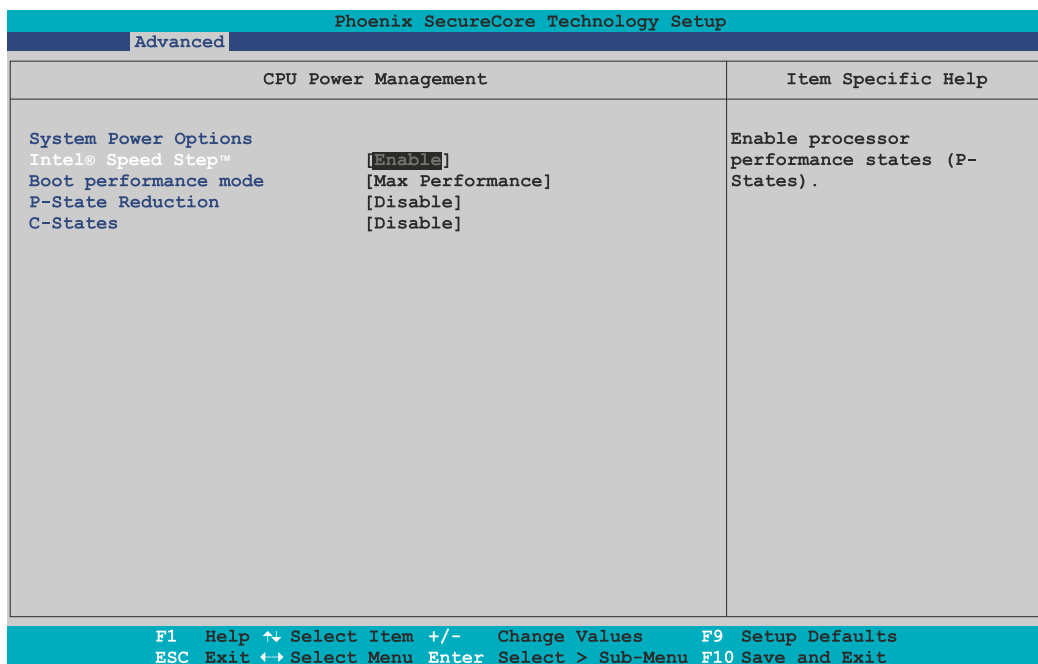

BIOS setting	Explanation	Configuration options	Effect
Intel SpeedStep	Option for controlling Intel SpeedStep Technology. The processor is clocked up or down according to the number of calculations to be performed. As a result, the energy consumption depends heavily on the utilization of the processor.	Disabled	Disables this function.
		Enabled	The processor speed is controlled by the operating system.
Boot performance mode	Option for setting the CPU speed. Information: This setting can be changed in ACPI operating systems by enabling Intel SpeedStep Technology.	Max performance	Maximum CPU and graphics speed.
		Max battery	The CPU and graphics speed is choked.
P-state reduction	Option for reducing CPU performance and power usage.	Disabled	Disables this function.
		By 1, 2, 3, 4, 5, 6, 7, 8	Reduces the performance by the configured value depending on the CPU being used.
C-states	This setting allows the operating system to set the clock frequency of the processor itself. This saves energy.	Disabled	Disables this function.
		Enabled	Enables this function; additional settings can be made.
Max C states ¹⁾	This setting controls the maximum C state that the processor supports.	C7	Maximum C state C7. The CPU voltage is completely switched off.
		C6	Maximum C state C6. The CPU voltage is reduced to almost 0 V.
		C1	Maximum C state C1. The processor is in sleep mode. Switch between C0 and C1.

1) This setting is only possible if *C-states* is set to *Enabled*.

7.1.6.3 Graphics (IGD) configuration

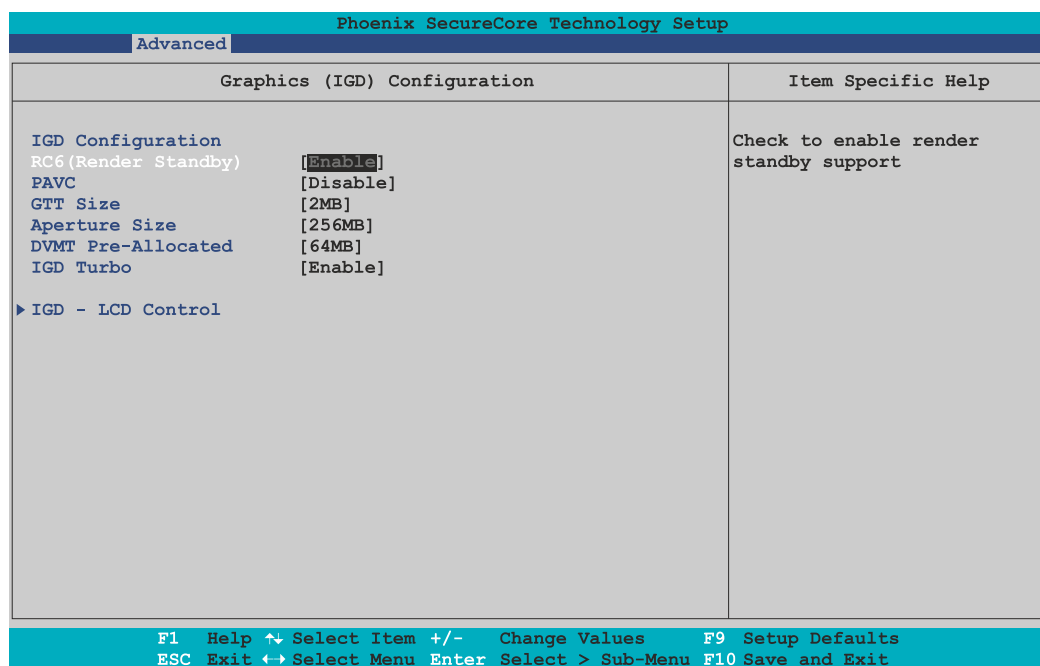

BIOS setting	Explanation	Configuration options	Effect
RC6 (render standby)	Option for enabling/disabling standby mode for the onboard graphics in order to consume less energy.	Disabled	Disables this function.
		Enabled	Enables this function.
PAVC	Protected Audio Video Control protects data on the PC.	Disabled	Disables this function.
		LITE mode	Reserves the memory.
		SERPENT mode	Reserves the memory; this is not recognized by the operating system.
GTT size	Option for setting the size of the graphics translation table (GTT).	1 MB	1 MB GTT
		2 MB	2 MB GTT
Aperture size	Option for setting the maximum amount of RAM made available to the main memory when graphics memory is full.	128 MB	Reserves 128 MB
		256 MB	Reserves 256 MB
		512 MB	Reserves 512 MB
DVMT pre-allocated	Option for setting the fixed memory size used for the internal graphics controller.	64 M, 96 M, 128 M, 160 M, 192 M, 224 M, 256 M, 288 M, 320 M, 352 M, 384 M, 416 M, 448 M, 480 M, 512 M	Defines the static graphics memory as a value between 64 and 512 MB.
IGD turbo	Option for setting the turbo boost on the graphics controller.	Disabled	Disables this function.
		Enabled	Enables this function.
IGD - LCD control	Configures the display settings of the connected panel.	Enter	Opens this submenu See "IGD - LCD control" on page 115.

7.1.6.3.1 IGD - LCD control

Phoenix SecureCore Technology Setup		
Advanced		
IGD Configuration	Item Specific Help	
IGD managed by: Legacy Video BIOS [3798]	Select the Video Device activated during POST. This has no effect if external graphics are present.	
LVDS EEPROM Data Data Format EPI Resolution 1024x768 Color Depth 24Bit Channel Count Single Channel		
IGD - Boot Type [Auto]		
LVDS Clock Center Spreading [No Spreading] Firmware PLL Range [Auto]		
EFP1 Type [DP with HDMI/DVI]		
Mode Persistence [Disable] Center Mode [Auto]		
F1 Help ↕ Select Item +/- Change Values F9 Setup Defaults ESC Exit ← Select Menu Enter Select > Sub-Menu F10 Save and Exit		

BIOS setting	Explanation	Configuration options	Effect
Data format	Displays the data format of the LFP ¹⁾ .	None	-
Resolution	Displays the display resolution of the LFP.	None	-
Color depth	Displays the color depth of the LFP display.	None	-
Channel count	Displays LFP channels.	None	-
IGD - Boot type	Option for defining the primary enabled display device during POST.	Auto	Automatic selection.
		CRT	The CRT (cathode ray tube) channel is used.
		EFP	The EFP (external flat panel) channel is used.
		LFP	The LFP (local flat panel) channel is used.
IGD - Secondary boot type ²⁾	Option for defining the secondary enabled display device during POST. Information: After the BIOS boot screen, this display and BIOS will no longer show anything until the graphics driver is re-loaded by the operating system.	Disabled	Disables this function.
		CRT	The CRT (cathode ray tube) channel is used.
		EFP	The EFP (external flat panel) channel is used.
		LFP	The LFP (local flat panel) channel is used.
LFP type ³⁾	Option for manually setting the LFP (local flat panel) type.	Auto	The LFP type is automatically set based on the EDID data.
		VGA 640 x 480 1x18 up to WUXGA 1920 x 1200 2 x 24	Manual adjustment of the resolution from 640 x 480 to 1920 x 1200.
LVDS clock center spreading	Option for modulating the LVDS clock frequency to slightly reduce electromagnetic interference.	No spreading	Disables this function.
		0.5%, 1.0%, 1.5%, 2.0%, 2.5%	The LVDS clock frequency varies around the set value and the EMC behavior can be improved.
Firmware PLL Range	Option for manual setting of the phase-locked loop.	Auto	The system uses 0x03 for SVGA resolution and 0x02 for all other resolutions.
		1.56%, 3.12%, 6.5%, 12.5%, 25%, 50%, 100%	Set manually.
EFP1 type ⁴⁾	Option for setting the type for external flat panel 1.	DisplayPort only	Configures the interface as a DisplayPort interface.
		DP with HDMI/DVI	The interface is configured as a DisplayPort with HDMI/DVI.
		HDMI/DVI	Configures the interface as an HDMI/DVI.
Mode "Persistence"	Mode "Persistence" means that the operating system can remember and restore past display connection configurations. For example, a dual DVI display configuration is automatically restored when both DVI monitors are reconnected, even if only one DVI monitor was connected and activated during a previous boot procedure.	Disabled	Disables this function.
		Enabled	Enables this function.

BIOS setting	Explanation	Configuration options	Effect
Center mode	For panels without a scaler chip, the image is centered.	Disabled	Disables this function.
		Auto	Enables this function for all connected panels/monitors.
		CRT	Enables this function for CRT monitors.
		EFP	Enables this function for panels.

- 1) LFP = Local flat panel
- 2) This setting is only possible if *IGD - Boot type* is set to *CRT*, *EFP* or *LFP*.
- 3) This setting is only possible if *IGD - Boot type* is set to *LFP*.
- 4) This setting is only possible if *IGD - Boot type* is set to *Auto* or *EFP*.

7.1.6.4 LAN

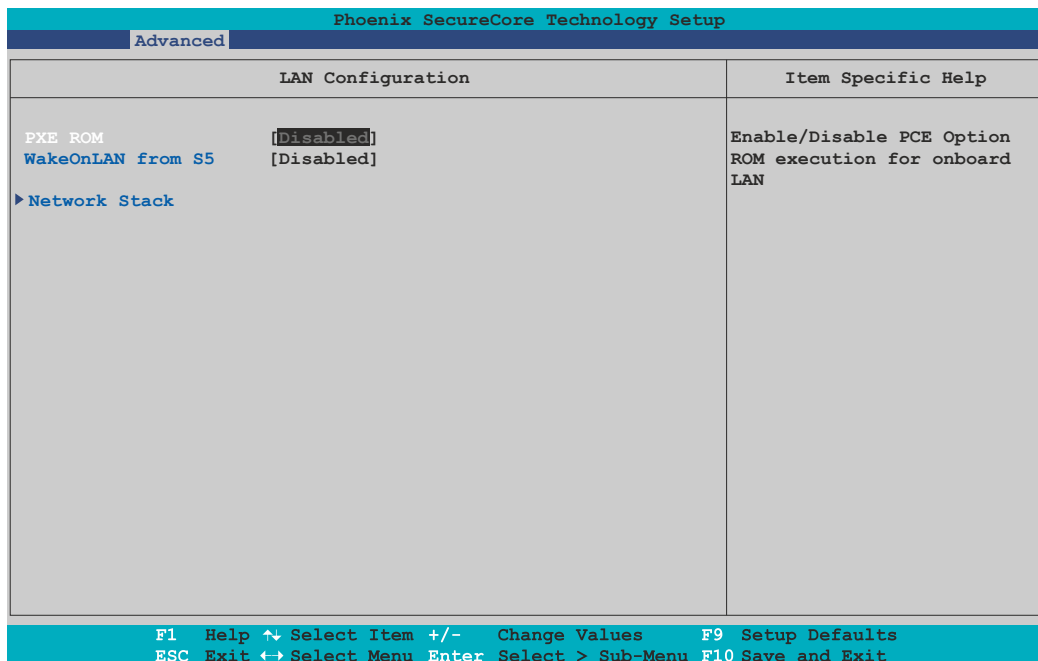

BIOS setting	Explanation	Configuration options	Effect
PXE ROM	Option for setting the PXE boot features.	Disabled	Disables this function.
		Onboard ETH1 only	Enables this function for ETH1.
		Onboard ETH2 only	Enables this function for ETH2.
		Both onboard only	Enables this function for ETH1 and ETH2.
		Add-on only	Enables this function for an optionally connected add-on card.
		Any	Enables this function for all devices, ETH1 and ETH2.
WakeOnLAN from S5	Option for switching on the system via the on-board Ethernet controller (ETH1) from mode S5.	Disabled	Disables this function. The Ethernet controller cannot switch on the system.
		Enabled	Enables this function. The Ethernet controller can switch on the system.
Network stack	Configures the network stack	Enter	Opens submenu "Network stack" on page 117

7.1.6.4.1 Network stack

Phoenix SecureCore Technology Setup		
Advanced		
Network Stack		Item Specific Help
Network Stack	[Enabled]	Enable/Disable UEFI Network Stack
IPv4	[Enabled]	
IPv6	[Enabled]	
F1 Help ↕ Select Item +/- Change Values F9 Setup Defaults ESC Exit ↔ Select Menu Enter Select > Sub-Menu F10 Save and Exit		

BIOS setting	Explanation	Configuration options	Effect
Network stack	Option for enabling/disabling the UEFI network stack	Disabled	Disables this function.
		Enabled	Enables this function.
IPv4	Option for enabling/disabling IPv4 PXE support.	Enabled	Enables this function.
		Disabled	Disables this function.
IPv6	Option for enabling/disabling IPv6 PXE support.	Enabled	Enables this function.
		Disabled	Disables this function.

7.1.6.5 PCI express configuration

Phoenix SecureCore Technology Setup		
Advanced		
PCI Express Configuration		Item Specific Help
<ul style="list-style-type: none"> ▶ PCI Express Root Port 0 ▶ PCI Express Root Port 1 (IF1) ▶ PCI Express Root Port 2 (ETH2) ▶ PCI Express Root Port 3 (ETH1) 		Configures PCI Express Root Port 0
F1 Help ↕ Select Item +/- Change Values F9 Setup Defaults ESC Exit ↔ Select Menu Enter Select > Sub-Menu F10 Save and Exit		

BIOS setting	Explanation	Configuration options	Effect
PCI Express root port 0	Configures PCI Express settings on port 0.	Enter	Opens this submenu See "PCI Express root port 0 to 3" on page 118.
PCI Express root port 1 (IF1)	Configures PCI Express settings on port 1 (interface option).	Enter	Opens this submenu See "PCI Express root port 0 to 3" on page 118.
PCI Express root port 2 (ETH2)	Configures PCI Express settings on port 2 (ETH2).	Enter	Opens this submenu See "PCI Express root port 0 to 3" on page 118.
PCI Express root port 3 (ETH1)	Configures PCI Express settings on port 3 (ETH1).	Enter	Opens this submenu See "PCI Express root port 0 to 3" on page 118.

7.1.6.5.1 PCI Express root port 0 to 3

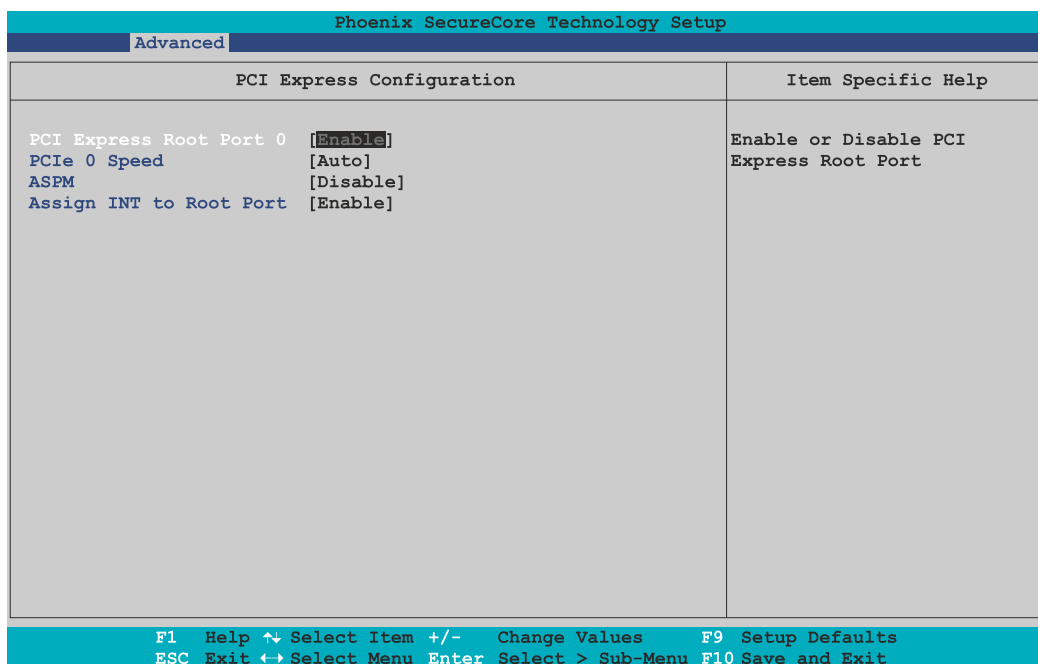

BIOS setting	Explanation	Configuration options	Effect
PCI Express root port x	Option for enabling/disabling the PCI Express root port x.	Enabled	Enables the PCI Express root port.
		Disabled	Disables the PCI Express root port.
PCIe x speed	Option for setting the PCI Express transfer rate.	Auto	Automatically sets the transfer rate.
		Gen1	Maximum transfer rate = 2.5 GT/s.
		Gen2	Maximum transfer rate = 5 GT/s.
ASPM	<i>Active State Power Management</i> Option for setting a power saving function (L0s/L1) for PCIe devices if they do not require full power.	Disabled	Disables this function.
		L0s	Enables the L0 energy saving function.
		L0sL1	Automatic assignment of L0s or L1 power saving function by the PCIe device.
Assign INT to root port	Option for enabling/disabling the IRQ for the root port.	Auto	Automatic assignment by BIOS and the operating system.
		Enabled	Enables this function.
		Disabled	Disables this function.

7.1.6.6 USB configuration

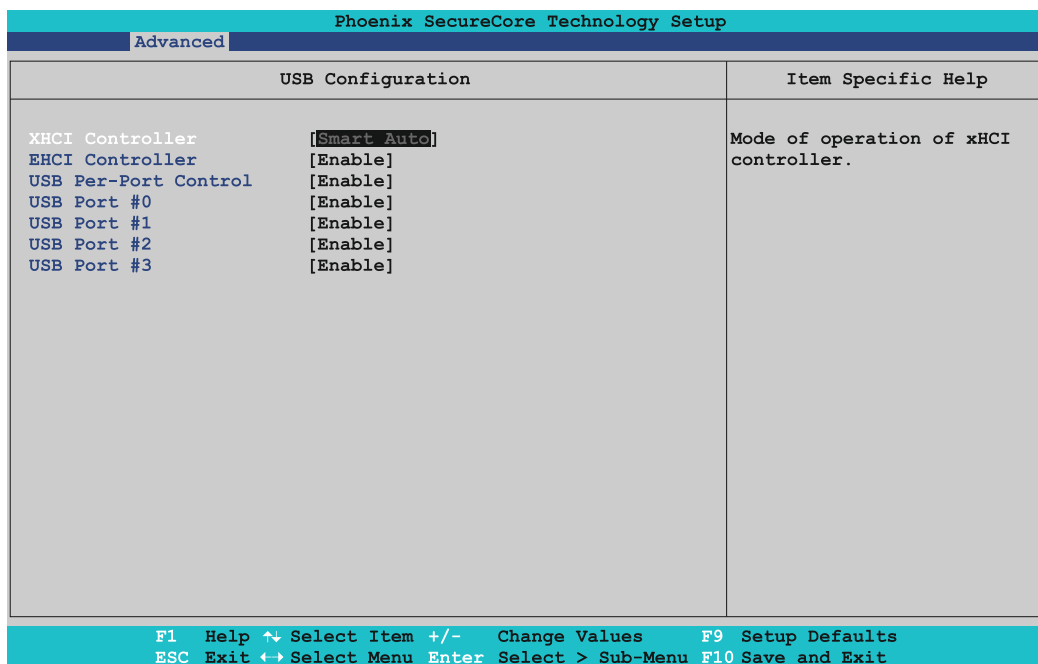

BIOS setting	Explanation	Configuration options	Effect
XHCI controller	Option for configuring the xHCI controller.	Smart auto	USB 3.0 interfaces are not handled as USB 3.0 until after the operating system has started. Until then, they are handled as USB 2.0 interfaces. If the PC is rebooted, then the USB 3.0 interfaces are still handled as USB 3.0 during booting.
		Disabled	Disables the xHCI controller. All USB 3.0 interfaces become USB 2.0 interfaces.
		Enabled	Enables the xHCI controller so that USB 3.0 interfaces are always identified as such.
EHCI controller	Configures USB EHCI controllers for the USB interfaces.	Disabled	Disables the EHCI controller.
USB per port control	Option for enabling/disabling individual USB interfaces.	Disabled	Hides the BIOS settings for "USB port #x".
		Enabled	Shows the BIOS settings for "USB port #x".
USB port #0	Option for enabling/disabling the USB1 interface.	Disabled	Disables this USB interface.
		Enabled	Enables this USB interface.
USB port #1	Option for enabling/disabling the USB2 interface.	Disabled	Disables this USB interface.
		Enabled	Enables this USB interface.
USB port #2	Option for enabling/disabling the monitor/panel option	Disabled	Disables this USB interface.
		Enabled	Enables this USB interface.
USB port #3	No function	Disabled	-
		Enabled	-

7.1.6.7 SATA configuration

Phoenix SecureCore Technology Setup	
Advanced	
SATA Configuration	Item Specific Help
Chipset SATA [Enable] Chipset SATA Mode [AHCI] SATA Port 0 Hot Plug Capability [Disable] SATA Port 1 Hot Plug Capability [Disable]	Enables or Disables the Chipset SATA Controller.
F1 Help ↕ Select Item +/- Change Values F9 Setup Defaults ESC Exit ↔ Select Menu Enter Select > Sub-Menu F10 Save and Exit	

BIOS setting	Explanation	Configuration options	Effect
Chipset SATA	Option for setting the SATA support.	Enabled	Provides support for SATA devices.
		Disabled	No support for SATA devices.
Chipset SATA mode	Option for setting supported serial ATA connections.	IDE	The serial ATA hard disk is used as a parallel ATA physical disk drive. It is not possible to configure the SATA ports.
		AHCI	The AHCI setting enables the internal memory driver for SATA functions, which increases the storage performance for random read-write access by allowing the drive itself to determine the sequence of commands.
SATA Port 0 hot plug capability	Option for setting the hot plugging for SATA port 0.	Enabled	Enables hot plugging for SATA interface 0. Devices can be connected/disconnected during operation.
		Disabled	Disables hot plugging for SATA port 0.
SATA Port 1 hot plug capability	Option for setting the hot plugging for SATA port 1.	Enabled	Enables hot plugging for SATA interface 1. Devices can be connected/disconnected during operation.
		Disabled	Disables hot plugging for SATA port 1.

7.1.6.8 Miscellaneous configuration

Phoenix SecureCore Technology Setup	
Advanced	
Miscellaneous Configuration	Item Specific Help
Realtime Environment [Disabled] Hypervisor Environment [Disabled] PCI MMIO Size [Auto] Extended Temperature Range [Disabled]	Enable or Disable the High Precision Event Timer
F1 Help ↕ Select Item +/- Change Values F9 Setup Defaults ESC Exit ↔ Select Menu Enter Select > Sub-Menu F10 Save and Exit	

BIOS setting	Explanation	Configuration options	Effect
Realtime environment	Configures settings for real-time operating systems such as Automation Runtime.	Disabled	Disables this function.
		Enabled	Disables DTS, turbo boost, SpeedStep, ASPM and the INT of root port 1 (IF). In addition, the CPU C-states are disabled and the boot performance mode is set to "Max. performance". Starting with BIOS V1.41, parameter "RC6" (render standby) is also disabled. The options that are configured and disabled by the real-time environment are grayed out and cannot be changed.
Hypervisor environment	This option configures settings for hypervisor operation.	Disabled	Disables this function.
		Enabled	VTX (Virtualization Technology) is enabled. The options that are configured by the hypervisor environment are grayed out and cannot be changed.
PCI MMIO size	Option for setting the PCI MMIO (memory mapped IO) size. Information: With 32-bit operating systems, the set MMIO size is stored under 4 GB in memory. This means that systems with 4 GB of main memory have less MMIO size available. This is not the case with 64-bit operating systems.	2 GB, 1.5 GB, 1.25 GB, 1 GB, Auto	Sets the selected memory size.
Extended temperature range	Option for setting the RAM refresh rate for extended temperature.	Disabled	Default RAM refresh rate.
		Enabled	Increases the RAM refresh rate.

7.1.6.9 Thermal configuration

Phoenix SecureCore Technology Setup	
Advanced	
Thermal Configuration	Item Specific Help
Thermal Configuration Parameters Critical Trip Point [+103°C / +217°F] Passive Trip Point [+95°C / +203°F]	This value controls the temperature of the ACPI Critical Trip Point - the point in which the OS will shut the system off.
F1 Help ↕ Select Item +/- Change Values F9 Setup Defaults ESC Exit ↔ Select Menu Enter Select > Sub-Menu F10 Save and Exit	

BIOS setting	Explanation	Configuration options	Effect
Critical trip point	This function sets the CPU temperature at which the operating system automatically shuts down the PC.	15°C / 59°F, 23°C / 73°F, 31°C / 88°F, 39°C / 102°F, 47°C / 117°F, 55°C / 131°F, 63°C / 145°F, 71°C / 160°F, 79°C / 174°F, 85°C / 185°F, 87°C / 189°F, 90°C / 194°F, 95°C / 203°F, 103°C / 217°F , 111°C / 232°F	Temperature setting for the critical trip point.
		Disabled	Disables this function.
Passive trip point	Function for setting a CPU temperature at which the operating system throttles the CPU speed.	15°C / 59°F, 23°C / 73°F, 31°C / 88°F, 39°C / 102°F, 47°C / 117°F, 55°C / 131°F, 63°C / 145°F, 71°C / 160°F, 79°C / 174°F, 85°C / 185°F, 87°C / 189°F, 90°C / 194°F, 95°C / 203°F , 103°C / 217°F	Temperature setting for the passive trip point.
		Disabled	Disables this function.

7.1.7 Security

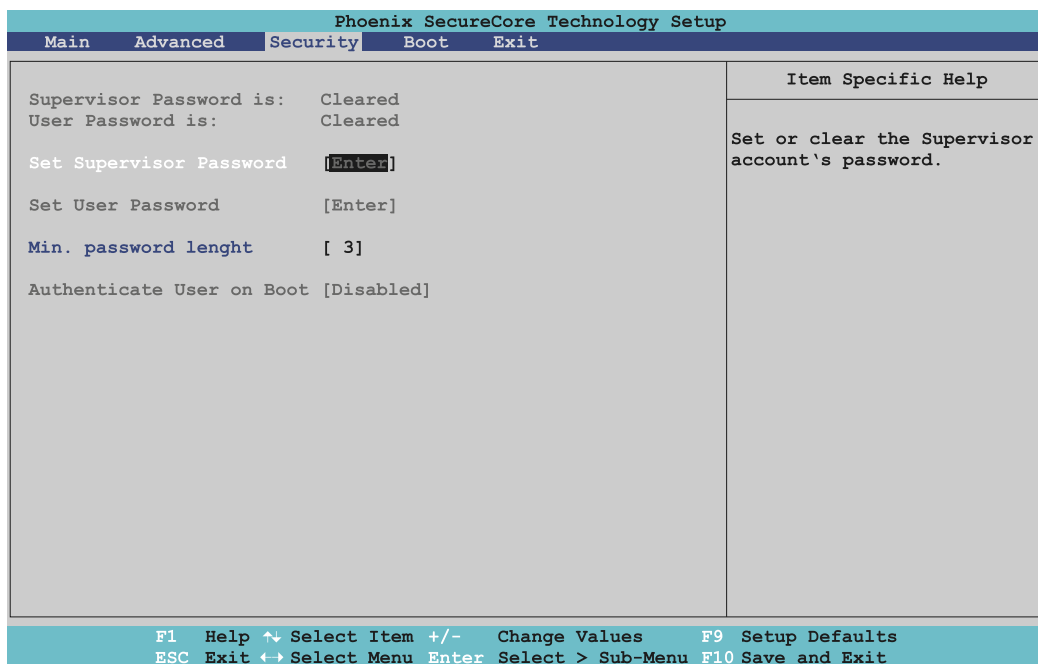

BIOS setting	Explanation	Configuration options	Effect
Supervisor password is:	Indicates whether a supervisor password has been assigned.	None	-
User password is:	Indicates whether a user password has been assigned.	None	-
Set supervisor password	Function for entering, changing and deleting a supervisor password. All BIOS settings can only be edited with the supervisor password.	Enter	Password entry.
Set user password ¹⁾	Function for entering, changing and deleting a user password. With the supervisor password, only certain BIOS settings can be edited.	Enter	Password entry.
Min. password length	Function for setting the minimum password length.	3 to 20	Enter the minimum password length.
Authenticate user on boot ¹⁾	Option for setting whether the user password must be entered for each boot procedure.	Disabled	A user password is not required for the boot procedure.
		Enabled	The user password must be entered for each boot procedure.

1) The setting can only be set if a *supervisor password* is assigned.

7.1.8 Boot

Phoenix SecureCore Technology Setup

Main	Advanced	Security	Boot	Exit
<p>▶ Boot Device Priority</p> <p>▶ Boot Configuration</p>	<p style="text-align: center;">Item Specific Help</p> <p>Press <Enter> to select the Boot Device Priority Configuration Setup options.</p>			
<p>F1 Help ↕ Select Item +/- Change Values F9 Setup Defaults</p> <p>ESC Exit ↔ Select Menu Enter Select > Sub-Menu F10 Save and Exit</p>				

BIOS setting	Explanation	Configuration options	Effect
Boot device priority	Configures the boot sequence.	Enter	Opens this submenu See "Boot device priority" on page 124.
Boot configuration	Configures boot settings.	Enter	Opens this submenu See "Boot configuration" on page 125.

7.1.8.1 Boot device priority

Phoenix SecureCore Technology Setup

Main	Advanced	Security	Boot	Exit	
<p style="text-align: center;">Boot Device Priority</p> <p>Boot Priority Order</p> <ol style="list-style-type: none"> 1. SATA HDD0: 2. USB CD: 3. USB FDD: 4. USBHDD P0: 5. USBHDD P1: 6. USBHDD P2: 7. USBHDD P3: 8. ATAPI CD: 9. SATA HDD1: 10. PCI LAN0: 11. PCI LAN1: 12. Watchdog 13. Internal Shell 				<p style="text-align: center;">Item Specific Help</p> <p>Key used to view or configure devices: ↑ and ↓ arrows Select a device. '+' and '-' move the device up or down. 'Shift +l' enables or disables a device. 'Del' deletes an unprotected device.</p>	
<p>F1 Help ↕ Select Item +/- Change Values F9 Setup Defaults</p> <p>ESC Exit ↔ Select Menu Enter Select > Sub-Menu F10 Save and Exit</p>					

BIOS setting	Explanation	Configuration options	Effect
Boot priority order	Option for setting the desired boot sequence.	SATA HDD0:	Specifies the desired boot sequence. Boot devices can be selected with the ↑ and ↓ arrow keys. Use "+" and "-" to change the sequence. "Shift + 1" activates/deactivates a boot device.
		USB CD:	
		USB FDD:	
		USBHDD P0:	
		USBHDD P1:	
		USBHDD P2:	
		USBHDD P3:	
		ATAPI CD:	
		SATA HDD1:	
		PCI LAN0:	
		PCI LAN1:	
		Watchdog ¹⁾	
Internal shell			

- 1) This watchdog can be used for sporadic recognition problems with CFast cards. If such a case occurs, a reset is triggered. If boot problems occur with SATA devices, their firmware version must be checked and updated if necessary.

7.1.8.2 Boot configuration

Phoenix SecureCore Technology Setup		
Boot		
Boot Configuration		Item Specific Help
NumLock	[On]	Selects Power-on state of Numlock.
Timeout	[2]	
CSM Support	[Yes]	
Quick Boot	[Disabled]	
Boot Logo Selection	[Auto]	
Diagnostic Splash Screen	[Disabled]	
Diagnostic Summary Screen	[Disabled]	
USB Legacy Support	[Enabled]	
Console Redirection	[Disabled]	
Allow Hotkey in S4 resume	[Enabled]	
UEFI Boot	[Enabled]	
Legacy Boot	[Enabled]	
Boot in Legacy Video Mode	[Disabled]	
Load OPROM	[On Demand]	
Boot Priority	[Legacy First]	
EFI BS Memory Allocation	[Disabled]	

F1 Help ↕ Select Item +/- Change Values F9 Setup Defaults
ESC Exit ↔ Select Menu Enter Select > Sub-Menu F10 Save and Exit

BIOS setting	Explanation	Configuration options	Effect
NumLock	Option for setting the numeric keypad when booting the system.	On	Enables the numeric keypad.
		Off	Only enables the cursor (movement) functions of the numeric keypad.
Timeout	Option for setting how long the setup activation key (key for entering BIOS) and boot logo is displayed.	2 to 99	Displays the setup activation key for x seconds.
CSM support	The compatibility support module (BIOS compatibility mode) supports backward compatibility for legacy BIOS settings of the legacy boot depending on the operating system.	Yes	BIOS compatibility mode is enabled and operating systems without UEFI support can be used. Legacy and UEFI boot are possible.
		No	The BIOS compatibility mode is enabled and only the UEFI boot is possible. Legacy boot is not supported.
Quick boot	This function reduces the boot time by skipping some POST procedures.	Disabled	Disables this function.
		Enabled	Enables this function.
Boot logo selection	Option for displaying the boot logo.	Disabled	The default logo is displayed.
		Enabled	The OEM logo is displayed.
		Auto	The OEM logo is automatically displayed if it exists.
Diagnostic splash screen	Setting for enabling/disabling the "Diagnostic splash screen" during the boot procedure.	Disabled	The "Diagnostic splash screen" is not displayed.
		Enabled	The "Diagnostic splash screen" is always displayed during the boot procedure.
Diagnostic summary screen	Option for enabling/disabling the "Diagnostic summary screen" during the boot procedure.	Disabled	Disables this function.
		Enabled	Enables this function.
USB legacy support	Option for setting the USB legacy support.	Disabled	Disables this function. The complete USB support is disabled (mouse, keyboard, USB mass storage, etc.).
		Enabled	Enables this function.

BIOS setting	Explanation	Configuration options	Effect
Console redirection	Option for setting the remote console. With the remote console, BIOS Setup can be accessed via the serial interface using a terminal emulator (PuTTY or HyperTerminal). Information: This function is only possible with IF option 5ACCIF01.FPLS-000 or 5ACCIF01.FPLS-001.	Disabled	Disables this function.
		Enabled	Enables this function.
Console port ¹⁾	Option for setting the serial interface.	All	Can be accessed via any serial interface.
		UART A, UART B, UART C, UART D, UART E, UART F	Accessed via the selected serial interface.
Terminal type ¹⁾	Option for setting keyboard input.	ANSI	Enables the ANSI convention (extended ASCII character set).
		VT100	Enables the VT100 convention (ASCII character set).
		VT100+	Enables the VT100+ convention (ASCII character set and support for color, function keys, etc.).
		UTF8	Enables the UTF-8 convention (uses UTF-8 encoding to assign Unicode characters to one or more bytes).
Baud rate ¹⁾	Option for setting the transfer rate of the serial interface (bits per second).	9600, 19200, 38400, 57600, 115200	Enables a transfer rate of x bits
Flow control ¹⁾	Option for setting the data flow control.	None	Disables data flow control.
		RTS/CTS	Enables hardware handshake.
		XON/XOFF	Enables software handshake.
Continue C.R. after POST ¹⁾	Option for enabling/disabling console redirection after POST.	Disabled	Disables this function.
		Enabled	Enables this function.
Allow hotkey in S4 resume	Option for enabling/disabling hotkey detection from the S4 state.	Disabled	Disables this function.
		Enabled	Enables this function. The PC exits the S4 state when a key is pressed.
UEFI boot	Option for enabling/disabling the UEFI boot.	Disabled	Disables this function.
		Enabled	Enables this function.
Legacy boot	Option for enabling/disabling the legacy boot.	Disabled	Disables this function.
		Enabled	Enables this function.
Boot in legacy video mode ²⁾	Option for enabling/disabling graphic initialization after BIOS POST with legacy ROM.	Disabled	Disables this function.
		Enabled	Enables this function. Information: Nothing is displayed after BIOS POST; the screen remains black.
Load OPROM ²⁾	Setting for loading all option ROMs or depending on the boot device.	All	All option ROMs are loaded.
		On demand	Option ROMs are loaded depending on the boot device.
Boot priority	Setting for prioritizing the boot option between UEFI and legacy boot.	UEFI first	Boots first from UEFI ROM.
		Legacy first	Boots first from legacy ROM.
EFI BS memory allocation	Option for setting the memory for the EFI boot services.	Disabled	The minimum memory required for EFI boot services is reserved.
		Enabled	The maximum memory required for EFI boot services (approx. 130 MB more) is reserved.

1) This setting is only possible if *Console redirection* is set to *Enabled*.

2) This setting is only possible if *Legacy boot* is set to *Enabled*.

7.1.9 Exit

Phoenix SecureCore Technology Setup				
Main	Advanced	Security	Boot	Exit
Exit Saving Changes Exit Discarding Changes Load Setup Defaults Discard Changes Save Changes				Item Specific Help Equal to F10, save all changes of all menus, then exit setup configure driver. Finally resets the system automatically.
F1 Help ↕ Select Item +/- Change Values F9 Setup Defaults ESC Exit ↔ Select Menu Enter Select > Sub-Menu F10 Save and Exit				

BIOS setting	Explanation	Configuration options	Effect
Exit saving changes	Selecting this option closes BIOS Setup. Selecting this option saves any changes made to CMOS after confirmation.	Yes/No	
Exit discarding changes	Selecting this option closes BIOS Setup without saving any changes made.	Yes/No	
Load setup defaults	Selecting this option restores the BIOS default values.	Yes/No	
Discard changes	Selecting this option resets any settings that may have been made but forgotten in the meantime (provided they have not yet been saved).	Yes/No	
Save changes	Selecting this option saves any changes made to CMOS after confirmation.	Yes/No	

7.1.10 Allocation of resources

7.1.10.1 RAM address assignment

Address in hexadecimal	Size	Resource
00000000 to 0009FFFF	640 kB	DOS (real mode) memory
000A0000 to 000BFFFF	128 kB	Video memory
000C0000 to 000CBFFF	48 kB	VGA BIOS
000CC000 to 000DFFFF	80 kB	Option ROM or XMS
000E0000 to 000FFFFFF	64 kB	System BIOS shadow RAM
00100000 to 7FFFFFFF	2 GB to 1 MB	System memory (low DRAM)
80000000 to FFF00000	2 GB to 1 MB	PCI low MMIO
FEC00000 to FEC00040	64 bytes	IO APIC
FED00000 to FED003FF	1 kB	HPET (timer)
FED01000 to FED1CFFF	112 kB	Chipset internal register space
FEE00000 to FEFFFFFF	2 MB	Local APIC
100000000 to 17FFFFFFF	2 GB	System memory (high DRAM)
180000000 to F00000000	58 GB	High MMIO

7.1.10.2 I/O address assignments

I/O address	Resource
0000h - 00FFh	Motherboard resources
02E8h - 02EFh	COM D (optional)
02F8h - 02FFh	COM B (optional)
0384h - 0385h	CAN controller (optional)
03B0h - 03DFh	Video system
03E8h - 03EFh	COM C (optional)
03F8h - 03FFh	COM A (optional)
0400h - 04FFh	Motherboard resources
0500h - 0G1Fh	Motherboard resources
0CF8h - 0CFBh	PCI config address register
0CFCh - 0CFFh	PCI config data register
0D00h - FFFFh	PCI / PCI Express bus
4100h - 41FFh	MTCX

7.1.10.3 Interrupt assignments in PIC mode

IRQ	0	1	2	3	4	5	6	7	8	9	10	11	12	13	14	15	NONE
System timer	•																
Keyboard		•															
IRQ cascade			•														
ACPI ¹⁾										•							
Real-time clock									•								
Co-processor (FPU)														•			
B&R Option- al	COM B ²⁾			•	○	○	○	○			○	○	○				
	COM C ³⁾				○	○	○	○			○	•	○				
	COM A ⁴⁾				○	•	○	○			○	○	○				
	COM D ⁵⁾				○	○	○	○			•	○	○				
	CAN				○	○	○	○			•	○	○				

- 1) Advanced Configuration and Power Interface
- 2) Resistive onboard touchscreen for Panel PC 2100
- 3) Monitor/Panel option, SDL/DVI transmitter, SDL3 transmitter
- 4) 5ACCIF01.FPLS-000 IF option, 5ACCIF01.FPLS-001, COM A.
- 5) IF option

- ... Default setting
- ... Optional setting

7.1.10.4 Interrupt assignments in APIC mode

A total of 23 IRQs are available in APIC (**A**dvanced **P**rogrammable **I**nterrupt **C**ontroller) mode. Enabling this option is only effective if done before the Windows operating system is installed.

IRQ	0	1	2	3	4	5	6	7	8	9	10	11	12	13	14	15	16	17	18	19	20	21	22	23	NONE
System timer	•																								
Keyboard		•																							
IRQ cascade			•																						
ACPI ¹⁾										•															
Real-time clock									•																
Co-processor (FPU)														•											
B&R Option- al	COM B ²⁾			•	○	○	○	○			○	○	○												
	COM C ³⁾				○	○	○	○			○	•	○												
	COM A ⁴⁾				○	•	○	○	○			○	○	○											
	COM D ⁵⁾				○	○	○	○	○		•	○	○												
	CAN				○	○	○	○	○		•	○	○												
PIRQ A ⁶⁾																	•								
PIRQ B ⁷⁾																		•							
PIRQ C ⁸⁾																			•						
PIRQ D ⁹⁾																				•					
PIRQ E ¹⁰⁾																					•				
PIRQ F ¹¹⁾																						•			
PIRQ G ¹²⁾																							•		
PIRQ H ¹³⁾																								•	

- 1) Advanced Configuration and Power Interface
- 2) Resistive onboard touchscreen for Panel PC 2100
- 3) Monitor/Panel option, SDL/DVI transmitter, SDL3 transmitter
- 4) 5ACCIF01.FPLS-000 IF option, 5ACCIF01.FPLS-001, COM A.
- 5) IF option
- 6) PIRQ A: For PCIe; PCI Express root port 0, VGA, controller
- 7) PIRQ B: For PCIe; PCI Express root port 1, optional interface option.
- 8) PIRQ C: For PCIe; PCI Express root port 2, SMBus controller, ETH2 controller
- 9) PIRQ D: For PCIe; PCI Express root port 3, serial ATA controller, ETH1 controller
- 10) PIRQ E: XHCI host controller
- 11) PIRQ F: Unused
- 12) PIRQ G: Optional high definition audio controller
- 13) PIRQ H: EHCI host controller

- ... Default setting
- ... Optional setting

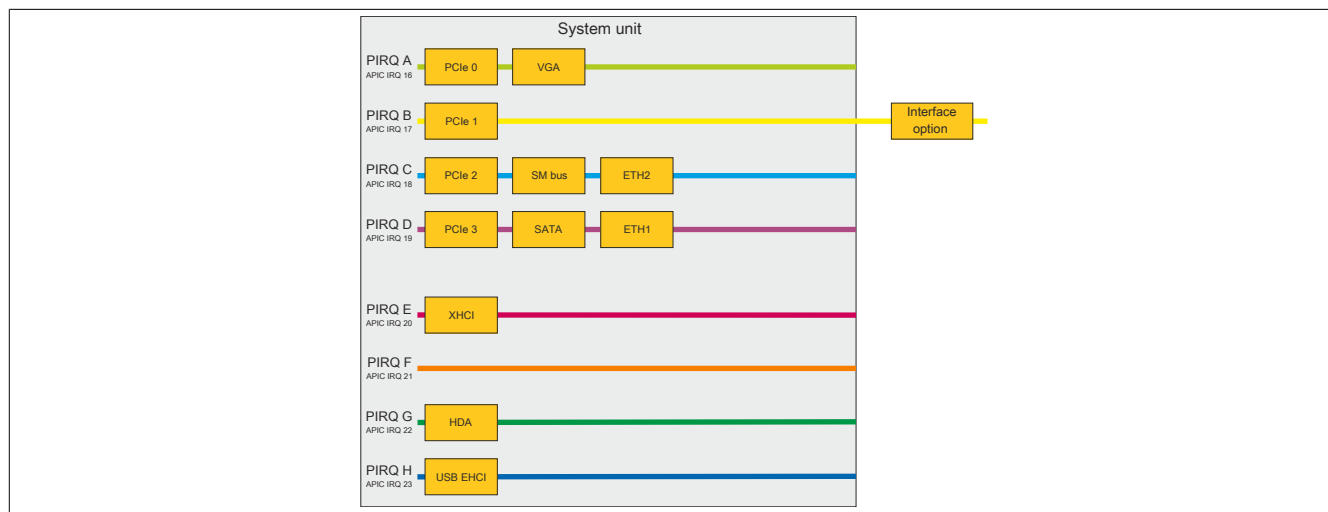

7.2 Upgrade information

Warning!

The BIOS and firmware on B&R devices must always be kept up to date. Current versions can be downloaded from the B&R website (www.br-automation.com).

7.2.1 BIOS upgrade

An upgrade may be necessary for the following reason, for example:

- To update the functions implemented in BIOS Setup or to add newly implemented functions or components (for information about changes, see the readme file of the BIOS upgrade).

7.2.1.1 Basic information

Information:

During a BIOS upgrade, individually saved BIOS settings are deleted.

It is helpful to determine the different software versions before starting the upgrade.

7.2.1.1.1 Which BIOS version and firmware are already installed?

This information is listed on the following BIOS Setup page.

- After switching on the PC, press "F2" to access BIOS Setup.
- Select "OEM features" from BIOS main menu "Advanced".

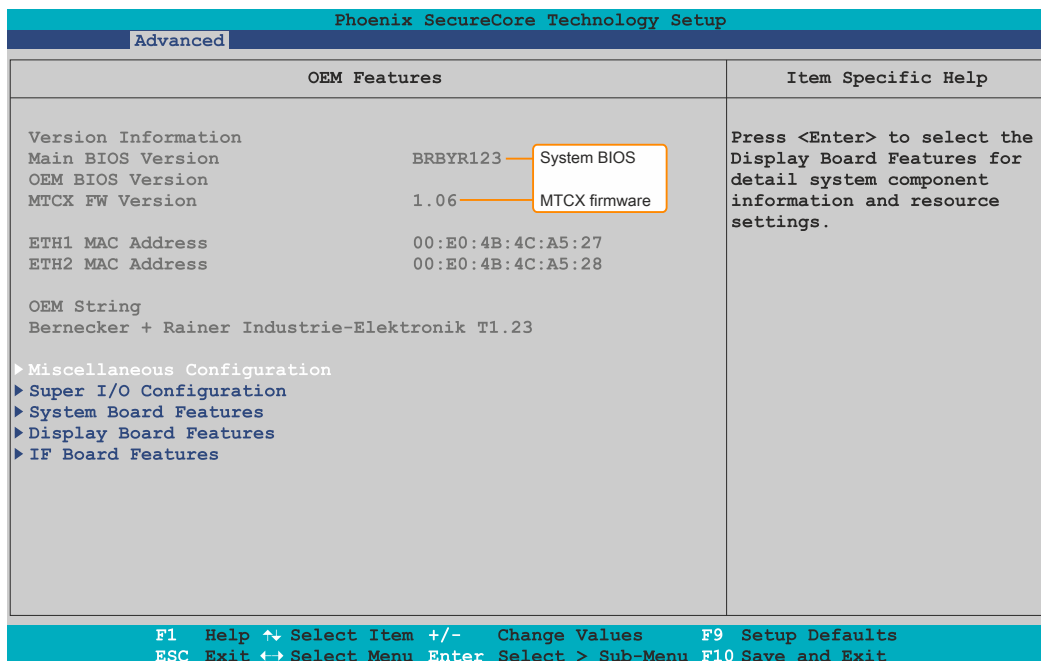

7.2.1.2 Procedure in the EFI shell

Caution!

The PC is not permitted to be switched off or reset while performing an upgrade!

1. Download the ZIP file from the B&R website (www.br-automation.com).
2. Unzip the ZIP file and copy the files to a USB flash drive formatted in FAT16 or FAT32. Alternatively, a CFast card can also be used.
3. Reboot the PC and select "Internal shell" as the boot device ("F5" key to open the boot menu).
4. After booting the EFI shell, "startup.nsh" is executed and the BIOS upgrade is started.
5. After a successful upgrade, the system must be rebooted.
6. Reboot and press key "F2" to enter BIOS Setup and load the setup defaults; then select "Save changes and exit".

7.2.2 Upgrading the firmware on the Automation PC 2100

With "Firmware upgrade (MTCX, SDLT, SDL3T)", it is possible to update the firmware of several controllers (MTCX, SDLT, SDL3T) depending on the variant of the APC2100 system.

A current firmware upgrade can be downloaded directly from the Downloads section of the B&R website (www.br-automation.com).

Caution!

The PC is not permitted to be switched off or reset while performing an upgrade!

7.2.2.1 Procedure in Windows (ADI Control Center)

1. Download the ZIP file from the B&R website (www.br-automation.com).
 2. Open the *ADI Control Center* in the Control Panel.
 3. Open tab **Versions**.
 4. Click on the desired update under **PC firmware** or **Panel firmware**. The dialog box opens.
 5. Enter the name of the firmware file or select a file under "Filename".
 6. Execute file with **Open**.
 7. After a successful upgrade, the system must be switched off and on again for the upgrade to take effect.
- ✓ The upgrade is installed and in effect.

The transfer can be canceled by clicking on **Cancel** in dialog box "Download". This is disabled while writing to flash memory.

Erasing the data in flash memory can take several seconds depending on the memory module used. During this time, the progress indicator is not updated.

Information:

For more detailed information about saving and updating the firmware, see the ADI driver user's manual. This is available for download at www.br-automation.com.

7.2.2.2 Procedure in the EFI shell

1. Download the ZIP file from the B&R website (www.br-automation.com).
2. Unzip the ZIP file and copy the files to a USB flash drive formatted in FAT16 or FAT32. Alternatively, a CFast card can also be used.
3. Reboot the PC and select "Internal shell" as the boot device ("F5" key to open the boot menu).
4. After booting the EFI shell, "startup.nsh" is executed and the MTCX, SDLT and SDL3T upgrades are started in sequence.
5. After a successful upgrade, a the system must be switched off and on again.

Warning!

Pressing panel keys during firmware transfer is not permitted! This can interfere with the process.

Information:

The power supply to the PC must be switched off and on again for the new firmware to take effect and the updated version to be displayed.

7.2.3 Automation Panel firmware upgrade

With *Firmware upgrade (Automation Panel, SDL3 Converter, SLD4 converter)*, it is possible to update the firmware of several controllers (SDLR, SDL3R, SDL4R, SDL3 Converter, SDL4 Converter) depending on the variant of the system.

A current firmware upgrade can be downloaded directly from the Downloads section of the B&R website (www.br-automation.com).

Caution!

The Automation Panel is not permitted to be switched off or reset while performing an upgrade!

7.2.3.1 Procedure in Windows (ADI Control Center)

1. Download the ZIP file from the B&R website (www.br-automation.com).
 2. Open the *ADI Control Center* in the Control Panel.
 3. Open tab **Versions**.
 4. Click on the desired update under **PC firmware** or **Panel firmware**. The dialog box opens.
 5. Enter the name of the firmware file or select a file under "Filename".
 6. Execute file with **Open**.
 7. After a successful upgrade, the system must be switched off and on again for the upgrade to take effect.
- ✓ The upgrade is installed and in effect.

The transfer can be canceled by clicking on **Cancel** in dialog box "Download". This is disabled while writing to flash memory.

Erasing the data in flash memory can take several seconds depending on the memory module used. During this time, the progress indicator is not updated.

Information:

For more detailed information about saving and updating the firmware, see the ADI driver user's manual. This is available for download at www.br-automation.com.

7.2.3.2 Procedure in EFI shell

Notice!

Pressing panel keys while transferring the firmware is not permitted! This can interfere with the process.

1. Download the ZIP file from the B&R website (www.br-automation.com).
 2. Unzip the ZIP file and copy the files to a USB flash drive formatted in *FAT16* or *FAT32*. Alternatively, a CFast card can also be used.
 3. Reboot the PC, open the boot menu with **[F5]** and select **Internal shell** as the boot device.
 4. After booting the EFI shell, *startup.nsh* is executed and the SDLR, SDL3R, SDL3 Converter upgrades are started in sequence.
 5. After a successful upgrade, the system must be switched off and on again for the upgrade to take effect.
- ✓ The upgrade is installed and in effect.

7.2.4 Firmware upgrade with Automation Runtime

The MTCX firmware is part of Automation Studio. The system is automatically updated to this status by Automation Runtime.

To update the firmware contained in Automation Studio, a hardware upgrade must be performed (see **Project management / Workspace / Upgrades** in Automation Help).

7.3 Operating systems

7.3.1 Windows 10 IoT Enterprise 2016 LTSB

7.3.1.1 General information

Information:

Discontinuation of support for Windows 10 IoT Enterprise 2016 LTSB by Microsoft:

Security updates, hotfixes, free or paid support and technical resources will no longer be offered after October 13, 2026.

Windows 10 IoT Enterprise 2016 LTSB is a version of Windows 10 Enterprise specifically developed for use in industrial applications (Long-Term Servicing Branch).

Information:

For detailed information, see the user's manual of the operating system. This is available for download on the B&R website (www.br-automation.com).

7.3.1.2 Order data

Order number	Short description	Figure
	Windows 10 IoT Enterprise 2016 LTSB	
5SWW10.0542-MUL	Windows 10 IoT Enterprise 2016 LTSB - 64-bit - Entry - Multilingual - APC2100 chipset Bay Trail - Processor E3826/E3827/E3845 - License - Only available with a new device	
	Optional accessories	
	Windows 10 IoT Enterprise 2016 LTSB	
5SWW10.0800-MUL	Windows 10 IoT Enterprise 2016 LTSB - 64-bit - Language Pack DVD	

7.3.1.3 Overview

Order number	5SWW10.0542-MUL
Operating system	
Target systems	
Industrial PC	APC2100
Processor	E3826, E3827, E3845
Chipset	Bay Trail
Edition	Entry
Architecture	64-bit (Legacy BIOS boot)
Language	Multilingual
Minimum size of RAM	2 GB ¹⁾
Minimum size of data storage medium	20 GB ²⁾

- 1) The specified memory size is a minimum requirement according to Microsoft. B&R recommends using 4 GB RAM or more for 64-bit operating systems.
- 2) The specified minimum size of the data storage medium does not take into account the memory requirements of additional language packages.

7.3.1.4 Features

The feature list shows the most important device functions in Windows 10 IoT Enterprise 2016 LTSB.

Function	Windows 10 IoT Enterprise 2016 LTSB
Range of functions in Windows 10 Enterprise	✓
Internet Explorer 11 including Enterprise Mode	✓
Multi-touch support	✓
Multilingual support	Can be installed via Language Pack DVDs (default language is English)
Page file	Configurable (disabled by default in the image by the UWF)
Hibernate file	Configurable (disabled by default in the image)
System restore	Configurable (disabled by default in the image by the UWF)
SuperFetch	Configurable (disabled by default in the image by the UWF)
File indexing service	Configurable (disabled by default in the image by the UWF)
Fast boot	Configurable (disabled by default in the image by the UWF)
Defragmentation service	✓ (Disabled when enabling the UWF)
Additional embedded lockdown functions	
Assigned access	Configurable
AppLocker	Configurable
Shell Launcher	Configurable
Unified Write Filter	✓
Keyboard Filter	Configurable

7.3.1.5 Installation

B&R preinstalls Windows 10 IoT Enterprise 2016 LTSC on a suitable data storage device (64-bit: minimum 20 GB). When switched on for the first time, the system runs through the out-of-box experience (OOBE), which allows different settings to be made (e.g. language, region, keyboard layout, computer name, username, etc.).

Windows 10 IoT Enterprise 2016 LTSC is installed on APC2100 and PPC2100 devices in Legacy BIOS mode.

Note when backing up or restoring the installation that the GPT file system must be supported by the software being used.

7.3.1.6 Drivers

The operating system contains all drivers necessary for operation. If an older driver version is installed, the current version can be downloaded and installed from the B&R website (www.br-automation.com). It is important to ensure that "Unified Write Filter (UWF)" is disabled.

Information:

Necessary drivers must be downloaded from the B&R website, not from manufacturer websites.

7.3.1.7 Activation

Windows 10 IoT Enterprise 2016 LTSC must be activated like its predecessor Windows 10 IoT Enterprise 2015 LTSC. This takes place at B&R.

The activation status can be checked in the Control Panel (symbolic image):

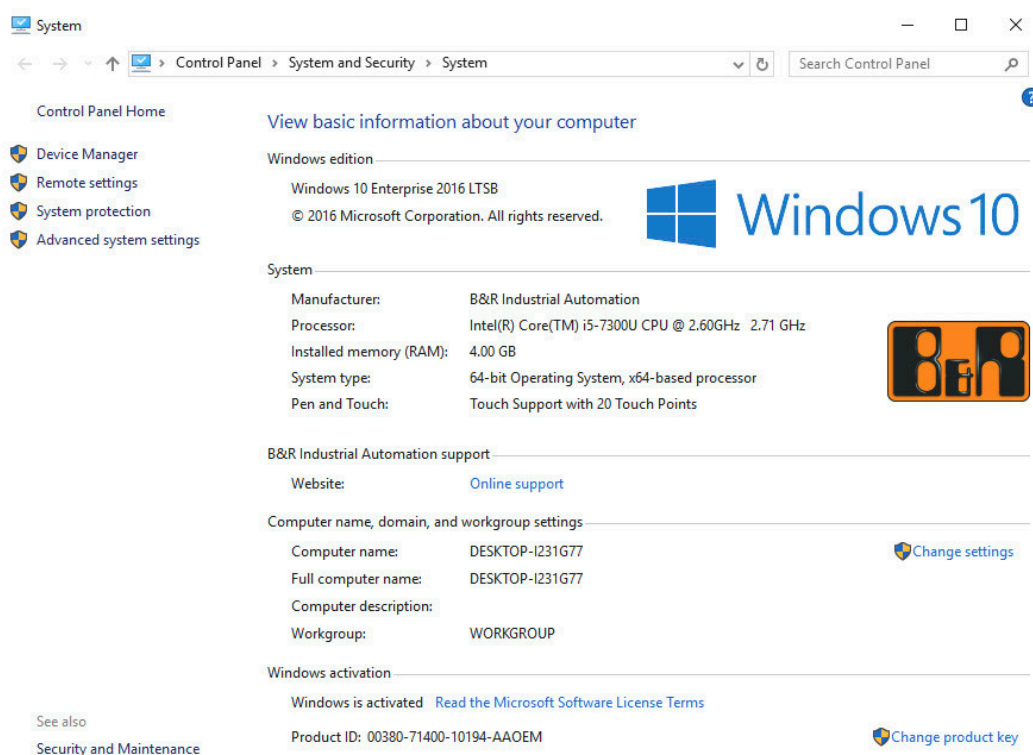

Activation carried out by B&R is supported by special B&R extensions in the operating system and theoretically not lost when the hardware is changed (e.g. replacement of components in the event of repair) or when the system is reinstalled, unlike Windows 10 IoT Enterprise 2015 LTSC (Microsoft reserves the right to make technical changes without notice).

Information:

It is not required to enter a product key for activation.

7.3.1.8 Characteristics, limitations

- Unlike standard Windows 10 Enterprise, Windows 10 IoT Enterprise 2016 LTSB does not include Cortana, the Microsoft Edge browser or the Microsoft Store, for example.
- The LTSB version is based on build 14393 of Windows 10 and does not receive any feature updates.

The version installed by B&R contains optimized settings for operation in an industrial environment. These are described in detail in a manual for Windows 10 IoT Enterprise 2016 LTSB. This can be downloaded at no cost from the Downloads section of the B&R website (www.br-automation.com) (login required).

Information:

These settings as well as the features not included in the LTSB version cause different behavior compared to a standard Windows 10 Enterprise installation.

7.3.1.9 Supported display resolutions

Per Microsoft requirements, Windows 10 IoT Enterprise 2016 LTSB requires SVGA resolution (800 x 600) or higher to enable full operation of the Windows user interface (including system dialog boxes, apps, etc.). A lower resolution can be selected for applications.

7.3.2 Windows 10 IoT Enterprise 2015 LTSB

7.3.2.1 General information

Information:

Discontinuation of support for Windows 10 IoT Enterprise 2015 LTSB by Microsoft:

Security updates, hotfixes, free or paid support and technical resources will no longer be offered after October 14, 2025.

Windows 10 IoT Enterprise 2015 LTSB is the successor to Windows Embedded 8.1 Industry and based on new Windows 10 technology. The operating system also offers a higher level of protection for industrial applications through additional lockdown functions. Windows 10 IoT Enterprise 2015 LTSB is a special version of Windows 10 Enterprise for industrial use (Long Term Servicing Branch).

Information:

For detailed information, see the user's manual of the operating system. This is available for download on the B&R website (www.br-automation.com).

7.3.2.2 Order data

Order number	Short description	Figure
	Windows 10 IoT Enterprise 2015 LTSB	
5SWW10.0242-MUL	Windows 10 IoT Enterprise 2015 LTSB - 64-bit - Multilingual - APC2100 chipset Bay Trail - License (without Recovery DVD) - Only available with a new device	
	Optional accessories	
	Windows 10 IoT Enterprise 2015 LTSB	
5SWW10.0200-MUL	Windows 10 IoT Enterprise 2015 LTSB - 64-bit - Multilingual - Recovery DVD	
5SWW10.0400-MUL	Windows 10 IoT Enterprise 2015 LTSB - 64-bit - Language Pack DVD	

7.3.2.3 Overview

Order number	5SWW10.0242-MUL
Operating system	
Target systems	
Industrial PC	APC2100
Processor	No limitations
Chipset	Bay Trail
Edition	Embedded
Architecture	64-bit
Language	Multilingual
Minimum size of RAM	2 GB ¹⁾
Minimum size of data storage medium	20 GB ²⁾

- 1) The specified memory size is a minimum requirement according to Microsoft. B&R recommends using at least 4 GB RAM with 64-bit operating systems, however.
- 2) The specified minimum size of the data storage medium does not take into account the memory requirements of additional language packages.

7.3.2.4 Features

The feature list shows the most important device functions in Windows 10 IoT Enterprise 2015 LTSB.

Function	Windows 10 IoT Enterprise 2015 LTSB
Range of functions of Windows 10 Enterprise 2015 LTSB	✓
Internet Explorer 11 including Enterprise Mode	✓
Multi-touch support	✓
Multilingual support	Can be installed via Language Pack DVDs (default language is English)
Page file	Configurable (disabled by default in the image by the UWF)
Hibernate file	Configurable (disabled by default in the image)
System restore	Configurable (disabled by default in the image by the UWF)
SuperFetch	Configurable (disabled by default in the image by the UWF)
File indexing service	Configurable (disabled by default in the image by the UWF)
Fast boot	Configurable (disabled by default in the image by the UWF)
Defragmentation service	Configurable (disabled by default in the image by the UWF)
Additional embedded lockdown functions	
Assigned access	Configurable
AppLocker	Configurable
Shell Launcher	Configurable
Unified Write Filter	✓

7.3.2.5 Installation

Windows 10 IoT Enterprise 2015 LTSP is preinstalled by B&R on a suitable data storage medium (64-bit: at least 20 GB). After the system has been switched on for the first time, it runs through the out-of-box experience (OOBE), which allows different settings to be made (e.g. language, region, keyboard, computer name, username).

7.3.2.6 Drivers

The operating system contains all drivers necessary for operation. If an older driver version is installed, the current version can be downloaded and installed from the B&R website (www.br-automation.com). It is important to ensure that "Unified Write Filter (UWF)" is disabled.

Information:

Necessary drivers must be downloaded from the B&R website, not from manufacturer websites.

7.3.2.7 Activation

Windows 10 IoT Enterprise 2015 LTSP must be activated like its predecessor Windows Embedded 8.1 Industry Pro. This takes place at B&R.

The activation status can be checked in the Control Panel (symbolic image):

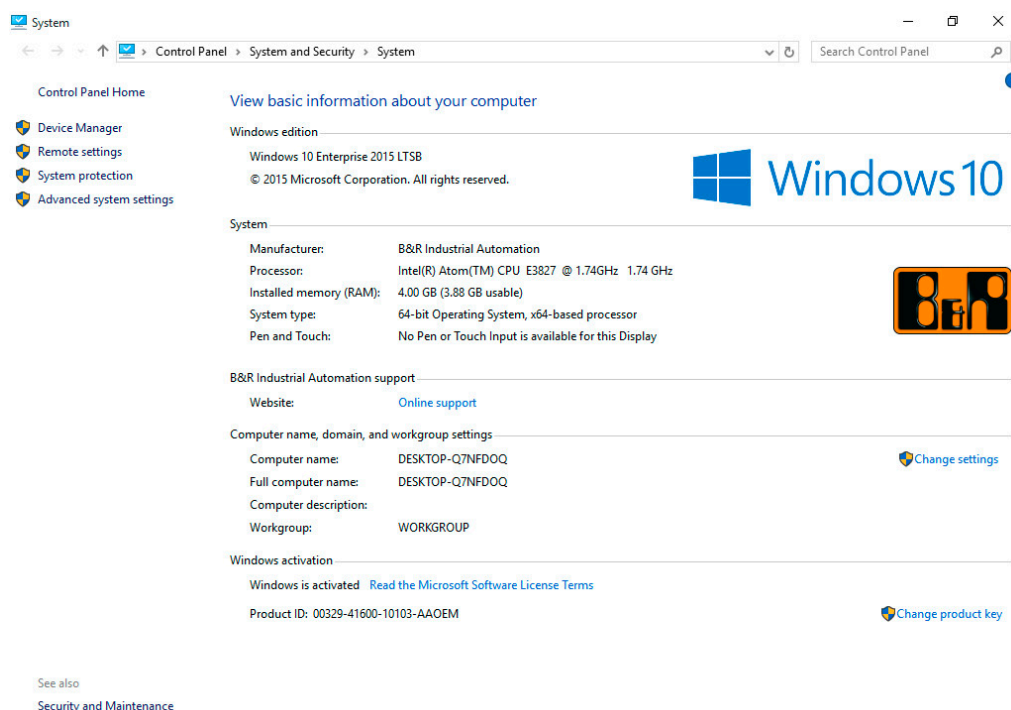

Information:

Activation may be lost if the hardware is changed (e.g. replacement of components in the event of repairs) or if the system is reinstalled (e.g. with the recovery DVD).

In this case, a message is displayed on the screen that is always visible (watermark):

Activate Windows
 Go to Settings to activate Windows.

Windows 10 IoT Enterprise 2015 LTSP does not carry out any restarts or show any pop-up messages, which means that it is fully functional at all times. "Personalization" is not possible, however (e.g. setting the desktop background image).

The product can be activated at a later time either over the phone or via the Internet. For corresponding instructions, see "Update & Security > Activation" in the Windows Control Panel.

Information:

Entering a product key is not required for a new activation in any case.

7.3.2.8 Content of delivery of the recovery DVD

The DVD with the order number 5SWW10.0200-MUL is for recovery purposes only.

Information:

This only performs the basic installation of a Windows 10 Enterprise 2015 LTSC. In contrast to the preinstalled operating system versions, the operating system does not include device-specific drivers (network, graphics, ADI, etc.) or optimized settings, nor is it activated! The product can be activated at a later time either over the phone or via the Internet (see "[Activation](#)").

7.3.2.9 Characteristics, limitations

- Unlike standard Windows 10 Enterprise, Windows 10 IoT Enterprise 2015 LTSC does not include Cortana, the Microsoft Edge browser or the Microsoft Store, for example.
- The LTSC version is based on build 10240 of Windows 10 and does not receive any feature updates.

The version installed by B&R contains optimized settings for operation in an industrial environment. These are described in detail in the "Windows 10 IoT 2015 LTSC working guide". This can be downloaded at no cost from the Downloads section of the B&R website (www.br-automation.com) (login required).

Information:

These settings as well as the features not included in the LTSC version cause different behavior compared to a standard Windows 10 Enterprise installation.

7.3.2.10 Supported display resolutions

Per Microsoft requirements, Windows 10 IoT Enterprise 2015 LTSC requires SVGA resolution (800 x 600) or higher to enable full operation of the Windows user interface (including system dialog boxes, apps, etc.). A lower resolution can be selected for applications.

7.3.3 Windows Embedded 8.1 Industry Pro

7.3.3.1 General information

Information:

Discontinuation of support for Windows Embedded 8.1 Industry Professional by Microsoft:

Security updates, hotfixes, free or paid support and technical resources will no longer be offered after July 11, 2023.

Windows Embedded 8.1 Industry Pro is an operating system specially tailored to industrial applications. It is based on the new Windows 8.1 technology and contains additional lockdown functions to make industrial PCs more secure. The system is based on the complete Windows 8.1 Pro operating system and therefore offers full compatibility for applications and drivers.

7.3.3.2 Order data

Order number	Short description	Figure
	Windows Embedded 8.1 Industry Pro	
5SWWI8.0342-MUL	Windows Embedded 8.1 Industry Pro - 32-bit - Multilingual - For the APC2100 - License	
5SWWI8.0442-MUL	Windows Embedded 8.1 Industry Pro - 64-bit - Multilingual - For the APC2100 - License	
	Optional accessories	
	Windows Embedded 8.1 Industry Pro	
5SWWI8.0100-MUL	Windows Embedded 8.1 Industry Professional - 32-bit - Recovery DVD	
5SWWI8.0200-MUL	Windows Embedded 8.1 Industry Professional - 64-bit - Recovery DVD	
5SWWI8.0500-MUL	Windows Embedded 8.1 Industry Professional - 32-bit - Language Pack DVD	
5SWWI8.0600-MUL	Windows Embedded 8.1 Industry Professional - 64-bit - Language Pack DVD	

7.3.3.3 Overview

Order number	5SWWI8.0342-MUL	5SWWI8.0442-MUL
Operating system		
Target systems		
Industrial PC		APC2100
Chipset		Bay Trail
Edition		Embedded
Architecture	32-bit	64-bit
Language		Multilingual
Minimum size of RAM	1 GB ¹⁾	2 GB ²⁾
Minimum size of data storage medium	16 GB ³⁾	20 GB ³⁾

- 1) If UWF (Unified Write Filter) is enabled, 2 GB RAM are recommended.
The specified memory size is a minimum requirement according to Microsoft. B&R recommends using at least 2 GB RAM with 32-bit operating systems, however.
- 2) The specified memory size is a minimum requirement according to Microsoft. B&R recommends using at least 4 GB RAM with 64-bit operating systems, however.
- 3) The specified minimum size of the data storage medium does not take into account the memory requirements of additional language packages.

7.3.3.4 Features

The feature list shows the most important device functions in Windows Embedded 8.1 Industry Pro.

Function	Windows Embedded 8.1 Industry Pro
Range of functions in Windows 8.1 Pro	✓
Internet Explorer 11 including Enterprise Mode	✓
Multi-touch support	✓
Multilingual support	Can be installed via Language Pack DVDs (default language is English)
Page file	Configurable (disabled by default in the image by the UWF)
Hibernate file	Configurable (disabled by default in the image)
System restore	Configurable (disabled by default in the image by the UWF)
SuperFetch	Configurable (disabled by default in the image by the UWF)
File indexing service	Configurable (disabled by default in the image by the UWF)
Fast boot	Configurable (disabled by default in the image by the UWF)
Defragmentation service	Configurable (disabled by default in the image by the UWF)
Additional embedded lockdown functions	
Assigned access	Configurable
Dialog box filter	Configurable
Embedded lockdown manager	✓

Function	Windows Embedded 8.1 Industry Pro
Keyboard Filter	Configurable
Shell Launcher	Configurable
Toast notification filter	Configurable
USB filter	Configurable
Unified Write Filter	✓
Windows 8 application launcher	Configurable
Gesture filter	Configurable

7.3.3.5 Installation

Windows Embedded 8.1 Industry Pro is preinstalled by B&R on a suitable data storage medium (32-bit: at least 16 GB, 64-bit: at least 20 GB). After the system is switched on for the first time, it runs through the out-of-box experience (OOBE), which allows different settings to be made (e.g. language, region, keyboard, computer name, username).

Information:

If entering the product key is required during the OOBE, this can be skipped by entering "SKIP".

7.3.3.6 Drivers

The operating system contains all drivers necessary for operation. If an older driver version is installed, the latest version can be downloaded and installed from the B&R website (www.br-automation.com). It is only important to ensure that "Unified Write Filter (UWF)" is disabled.

Information:

Necessary drivers must be downloaded from the B&R website, not from manufacturer websites.

7.3.3.7 Activation

Windows Embedded 8.1 Industry Pro must be activated in contrast to the previous versions Windows 7 and Windows XP Pro. This takes place at B&R.

The activation status can be checked in the Control Panel:

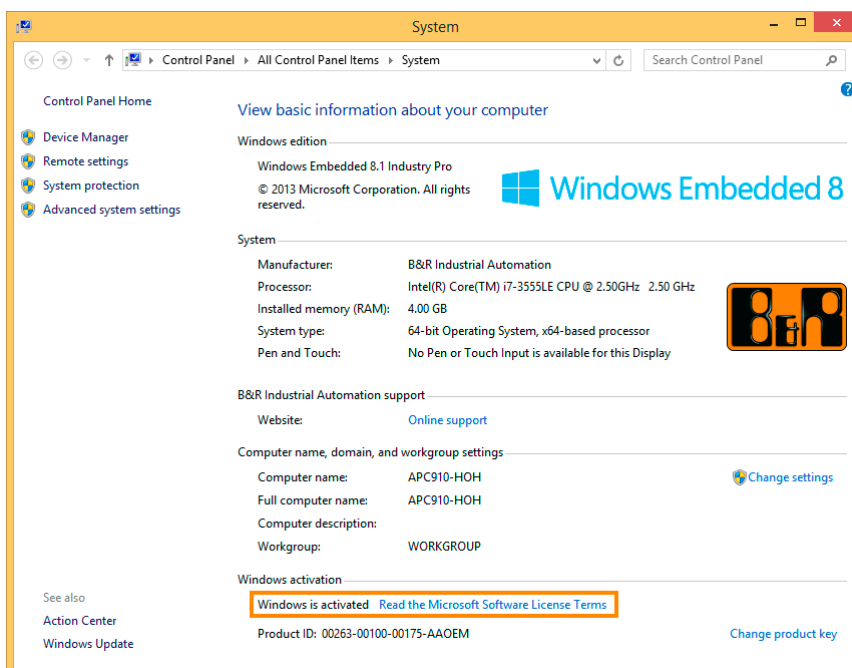

Information:

Activation may be lost if the hardware is changed (e.g. if components are replaced in case of repair) or if the system is reinstalled (e.g. with the recovery DVD).

In this case, a "watermark message" will always be shown on the screen:



Windows Embedded 8.1 Industry Pro does not carry out any restarts or show any pop-up messages, which means that it is fully functional at all times. Only "personalizations" (e.g. setting the desktop background image) cannot be carried out.

The product can be activated at a later time either over the phone or via the Internet. Instructions are available on the Microsoft website.

Activation via direct Internet connection:

[http://msdn.microsoft.com/en-us/library/dn449258\(v=winembedded.82\).aspx](http://msdn.microsoft.com/en-us/library/dn449258(v=winembedded.82).aspx)

Activation by telephone:

[http://msdn.microsoft.com/en-us/library/dn449379\(v=winembedded.82\).aspx](http://msdn.microsoft.com/en-us/library/dn449379(v=winembedded.82).aspx)

Information:

Entering a product key is not required for a new activation in any case.

7.3.3.8 Content of delivery of the recovery DVD.

DVDs with order numbers 5SWWI8.0100-MUL and 5SWWI8.0200-MUL are only for recovery purposes.

Information:

This only performs the basic installation of a Windows Embedded 8.1 Industry Pro. In contrast to the preinstalled operating system versions, the operating system does not include device-specific drivers (network, graphics, ADI, etc.) or optimized settings, nor is it activated! The product can be activated at a later time either over the phone or via the Internet (see "Activation").

7.3.3.9 Lockdown features

The lockdown functions in Windows Embedded 8.1 Industry Pro make it possible to individually configure the device while making the system more secure at the same time. Among other things, they include:

- Unified Write Filter (UWF):
This allows a data storage medium (e.g. CFast card) to be configured for read-only access, for example, and only certain registry keys can be accessed. As a result, the system always starts with the same configuration after rebooting.
- Dialog box filter:
This can be used to suppress pop-up windows and dialog boxes. Such dialog boxes can occur, for example, if virus scanners are updated, network connections fail or the Windows Security Center shows warnings. These dialog boxes are simply hidden.
- Keyboard Filter:
This allows individual keys or key combinations to be locked, e.g. so that the user cannot access the Task Manager.

For further information about the lockdown functions, see the Microsoft website:

[http://msdn.microsoft.com/en-us/library/dn449278\(v=winembedded.82\).aspx](http://msdn.microsoft.com/en-us/library/dn449278(v=winembedded.82).aspx)

7.3.3.10 Supported display resolutions

Per Microsoft requirements, Windows Embedded 8.1 Industry Pro requires XGA resolution (1024 x 768) or higher to enable full operation of the Windows user interface (including system dialog boxes, apps, etc.). A lower resolution can be selected for applications.

7.3.4 Windows 7

7.3.4.1 General information

Information:

Discontinuation of support for Windows 7 by Microsoft:

After January 14, 2020, Microsoft will no longer be providing any security updates, hotfixes, support (free or paid) or technical resources for Windows 7.

Windows 7 offers a variety of innovative features and performance enhancements. The 64-bit variants make full use of the current PC infrastructure. Faster switching to sleep mode, quicker restores, less memory usage and high-speed detection of USB devices are just a few of the advantages provided by Windows 7. Both English and German are available in Windows 7 Professional, while Windows 7 Ultimate supports up to 35 different languages (up to 36 languages in Service Pack 1). Product activation is not required for use on B&R PCs, which is a great advantage for simple logistical processes in the area of machine automation.

All Windows operating systems offered by B&R are from the Microsoft Embedded division. This means considerably longer availability compared to the consumer market.

7.3.4.2 Order data

Order number	Short description	Figure
	Windows 7 Professional/Ultimate	
5SWWI7.1100-GER	Windows 7 Professional SP1 - 32-bit - German - DVD	
5SWWI7.1100-ENG	Windows 7 Professional SP1 - 32-bit - English - DVD	
5SWWI7.1200-GER	Windows 7 Professional SP1 - 64-bit - German - DVD	
5SWWI7.1200-ENG	Windows 7 Professional SP1 - 64-bit - English - DVD	
5SWWI7.1300-MUL	Windows 7 Ultimate SP1 - 32-bit - Multilingual - DVD	
5SWWI7.1400-MUL	Windows 7 Ultimate SP1 - 64-bit - Multilingual - DVD	

7.3.4.3 Overview

Order number	5SWWI7.1100-GER	5SWWI7.1100-ENG	5SWWI7.1200-GER	5SWWI7.1200-ENG	5SWWI7.1300-MUL	5SWWI7.1400-MUL
Operating system						
Target systems						
Industrial PC	APC510 APC511 APC810 APC910 APC2100 PPC800 PPC900 PPC2100 PP500		APC810 APC910 APC2100 PPC800 PPC900 PPC2100		APC510 APC511 APC810 APC910 APC2100 PPC800 PPC900 PPC2100 PP500	APC810 APC910 APC2100 PPC800 PPC900 PPC2100
Chipset	945GME GM45 QM77/HM76 NM10 US15W Bay Trail		945GME GM45 QM77/HM76 QM170/HM170/CM236 Bay Trail		945GME GM45 QM77/HM76 NM10 US15W Bay Trail	945GME GM45 QM77/HM76 QM170/ HM170/CM236 Bay Trail
Edition	Professional			Ultimate		
Architecture	32-bit		64-bit		32-bit	64-bit
Service pack	SP1					
Language	German	English	German	English	Multilingual	
Minimum size of RAM	1 GB ¹⁾		2 GB ²⁾		1 GB ¹⁾	2 GB ²⁾
Required storage space on data storage medium	16 GB		20 GB		16 GB ³⁾	20 GB ³⁾

- 1) The specified memory size is a minimum requirement according to Microsoft. B&R recommends using at least 2 GB RAM with 32-bit operating systems, however.
- 2) The specified memory size is a minimum requirement according to Microsoft. B&R recommends using at least 4 GB RAM with 64-bit operating systems, however.
- 3) The memory space required by additional language packs is not taken into account in the minimum size for the data storage medium.

7.3.4.4 Installation

Windows 7 is preinstalled by B&R on the desired data storage medium (e.g. CFast card). All necessary drivers (graphics, network, etc.) for operation are also installed.

7.3.4.5 Drivers

Current drivers for all approved operating systems are available for download in the Downloads section of the B&R website (www.br-automation.com).

Information:

Necessary drivers must be downloaded from the B&R website, not from manufacturer websites.

7.3.4.6 Characteristics, limitations

- Beep.sys no longer exists in Windows 7; therefore, an acoustic signal (e.g. when a button is pressed) can no longer be heard.
- Determining the Windows 7 system assessment (system classification) is currently not supported (this does not apply to PP500, APC2100, APC510, APC511, APC910, PPC2100 and PPC800 with NM10 chipset).

Information:

32-bit operating systems are not recommended for system units with 4 GB or more of main memory. For further information, see section "[Miscellaneous configuration](#)" on page 120 under "PCI MMIO size".

7.3.4.7 Supported display resolutions

Per Microsoft requirements, Windows 7 requires XGA resolution (1024 x 768) or higher to enable full operation of the Windows user interface (including system dialog boxes, etc.). A lower resolution can be selected for applications.

7.3.5 Windows Embedded Standard 7

7.3.5.1 General information

Information:

Discontinuation of support for Windows Embedded Standard 7 by Microsoft:

After October 13, 2020, Microsoft will no longer be providing any security updates, hotfixes, support (free or paid) or technical resources for Windows Embedded Standard 7.

The successor variant to Windows XP Embedded is Windows Embedded Standard 7. As with previous versions, the embedded operating system offers full system support for B&R industrial PCs. In addition to new features that are also included in Windows 7 Professional, Windows Embedded Standard 7 includes embedded components such as Enhanced Write Filter, File-Based Write Filter, Registry Filter and USB boot. Windows Embedded Standard 7 is available in two versions. The main difference is the ability to execute in multiple languages. Windows Embedded Standard 7 is only available in a single language, whereas Windows Embedded Standard 7 Premium supports the installation of several languages simultaneously.

With Windows Embedded Standard 7, Microsoft has made substantial improvements in the area of security. The AppLocker program, available in the premium variant, can prevent the execution of unknown or potentially undesired applications that are being installed over a network or from drives that are directly connected. A tiered approach allows the differentiation between scripts (.ps1, .bat, .cmd, .vbs and .js), installation files (.msi, .msp) and libraries (.dll, .ocx). AppLocker can also be configured to record undesired activity and display it in the Event Viewer. Windows Embedded Standard 7 is available in both 32-bit and 64-bit versions (64-bit versions are not supported by all systems). As a result, even demanding applications based on 64-bit technology are supported.

7.3.5.2 Order data

Order number	Short description	Figure
	Windows Embedded Standard 7	
5SWWI7.1542-ENG	Windows Embedded Standard 7 SP1 - 32-bit - Service Pack 1 - English - APC2100 - License (without Recovery DVD) - Only available with a new device	
5SWWI7.1642-ENG	Windows Embedded Standard 7 SP1 - 64-bit - Service Pack 1 - English - APC2100 - License (without Recovery DVD) - Only available with a new device	
5SWWI7.1742-MUL	Windows Embedded Standard 7 Premium SP1 - 32-bit - Service Pack 1 - English - APC2100 - License (without Recovery DVD) - Only available with a new device	
5SWWI7.1842-MUL	Windows Embedded Standard 7 Premium SP1 - 64-bit - Service Pack 1 - English - APC2100 - License (without Recovery DVD) - Only available with a new device	
	Optional accessories	
	Windows Embedded Standard 7	
5SWWI7.1900-MUL	Windows Embedded Standard 7 SP1 - 32-bit - Language Pack DVD	
5SWWI7.2000-MUL	Windows Embedded Standard 7 SP1 - 64-bit - Language Pack DVD	

7.3.5.3 Overview

Order number	5SWWI7.1542-ENG	5SWWI7.1642-ENG	5SWWI7.1742-MUL	5SWWI7.1842-MUL
Operating system				
Target systems				
Industrial PC	APC2100			
Chipset	Bay Trail			
Edition	Embedded		Premium	
Architecture	32-bit	64-bit	32-bit	64-bit
Service pack	SP1			
Language	English		Multilingual	
Minimum size of RAM	1 GB ¹⁾	2 GB ²⁾	1 GB ¹⁾	2 GB ²⁾
Minimum size of data storage medium	16 GB		16 GB ³⁾	

- 1) The specified memory size is a minimum requirement according to Microsoft. B&R recommends using at least 2 GB RAM with 32-bit operating systems, however.
- 2) The specified memory size is a minimum requirement according to Microsoft. B&R recommends using at least 4 GB RAM with 64-bit operating systems, however.
- 3) The memory space required by additional language packs is not taken into account in the minimum size for the data storage medium.

7.3.5.4 Features

The feature list shows the most important device functions in Windows Embedded Standard 7.

Function	Windows Embedded Standard 7	Windows Embedded Standard 7 Premium
Enhanced Write Filter (EWF)	✓	✓
File Based Write Filter (FBWF)	✓	✓
Administrator account	✓	✓
User account	Configurable	Configurable
Windows Explorer shell	✓	✓
Registry filter	✓	✓
Internet Explorer 11.0	✓	✓
Internet Information Service (IIS) 7.0	✓	✓
Anti-malware (Windows Defender)	-	✓
Add-ons (Snipping Tool, Sticky Notes)	-	✓
Windows firewall	✓	✓
.NET Framework 3.5	✓	✓
32-bit and 64-bit support	✓	✓
Remote Desktop Protocol 7.0	✓	✓
File compression utility	✓	✓
Windows Installer service	✓	✓
Windows XP mode	-	-
Media Player 12	✓	✓
DirectX	✓	✓
Multilingual user interface packs in the same image	-	✓
International components and language services	✓	✓
Language pack installer	✓	✓
Windows Update	Configurable	Configurable
Windows PowerShell 2.0	✓	✓
BitLocker	-	✓
AppLocker	-	✓
Tablet PC support	-	✓
Multi-touch support	-	✓
Boot from USB stick	✓	✓
Accessories	✓	✓
Page file	Configurable	Configurable
Number of fonts	134	134

Table 39: Device functions in Windows Embedded Standard 7

7.3.5.5 Installation

Windows Embedded Standard 7 is preinstalled by B&R on a suitable CFast card (32-bit: at least 16 GB, 64-bit: at least 16 GB). After the system is switched on for the first time, it is configured automatically. This procedure takes approx. 30 minutes, and the device will be automatically rebooted a number of times.

Information:

If the EWF (Enhanced Write Filter) should be used, all mass storage devices (except the boot drive) must be removed from the system during setup or SYSPREP. Alternatively, the additional mass storage devices can also be disabled in BIOS.

7.3.5.6 Drivers

The operating system contains all drivers necessary for operation. If an older driver version is installed, the most current version can be downloaded and installed from the B&R website (www.br-automation.com). It is only important to ensure that "Enhanced Write Filter (EWF)" is disabled.

7.3.5.7 Characteristics, limitations

Information:

32-bit operating systems are not recommended for system units with 4 GB or more of main memory. For further information, see section "[Miscellaneous configuration](#)" on page 120 under "PCI MMIO size".

7.3.5.8 Supported display resolutions

Per Microsoft requirements, Windows Embedded Standard 7 requires XGA resolution (1024 x 768) or higher to enable full operation of the Windows user interface (including system dialog boxes, etc.). A lower resolution can be selected for applications.

7.3.6 Automation Runtime

7.3.6.1 General information

The real-time operating system Automation Runtime is an integral part of Automation Studio. This real-time operating system forms the software core for running applications on a target system.

- Guarantees the highest possible performance of the hardware being used
- Runs on all B&R target systems
- Makes the application hardware-independent
- Easy portability of applications between B&R target systems
- Guaranteed determinism through cyclic system
- Configurable jitter tolerance in all task classes
- Support for all relevant programming languages, such as IEC 61131-3 languages and C
- Rich function library per IEC 61131-3 as well as the extended B&R automation library
- Integrated in Automation NET. Access to all networks and bus systems via function calls or by configuration in Automation Studio

B&R Automation Runtime is fully embedded in the corresponding target system (hardware on which Automation Runtime is installed). It thus enables application programs to access I/O systems (also via the fieldbus) and other devices such as interfaces and networks.

7.3.6.2 Order data

Order number	Short description	Figure
	Technology Guard	
0TG1000.01	Technology Guard (MSD)	
0TG1000.02	Technology Guard (HID)	
1TG4600.10-5	Automation Runtime Windows TG license	
1TG4601.06-5	Automation Runtime Embedded, TG license	

7.3.6.3 Automation Runtime Windows (ARwin)

System requirements

The following software versions (or higher) are required to run Automation Runtime Windows on an Automation PC 2100:

- ARwin upgrade AR C4.10
- ARwin upgrade AR N4.10 for 5APC2100.BY48-000
- Automation Studio V4.1.4.0
- Technology Guard

Information:

In order to operate Automation Runtime Windows (ARwin), BIOS setting *Advanced - Miscellaneous configuration - Realtime environment* must be set to *Enabled*.

Information:

To slightly improve the real-time behavior (jitter) of Automation Runtime Windows (ARwin) with a graphics-heavy application, BIOS settings *Advanced - Graphics (IGD) configuration - IGD turbo* and *Advanced - Graphics (IGD) configuration - RC6 (render standby)*⁴⁾ can be set to *Disabled*.

If the BIOS setting *Advanced - Graphics (IGD) Configuration - IGD Turbo* is set to *Disabled*, the graphics performance of the system is noticeably reduced.

7.3.6.4 Automation Runtime Embedded (ARemb)

System requirements

The following software versions (or higher) are required to operate Automation Runtime Embedded on an Automation PC 2100:

- ARemb upgrade AR C4.10
- ARemb upgrade AR N4.10 for 5APC2100.BY48-000
- Automation Studio V4.1.4.0
- Visual Components Runtime (VC) V4.15.1
- Process Visualization Interface (PVI) V4.1.5
- Technology Guard

PVI Development Setup must be downloaded from the B&R website (www.br-automation.com) and installed separately!

Information:

In order to operate Automation Runtime Embedded (ARemb), BIOS setting *Advanced - Miscellaneous configuration - Realtime environment* must be set to *Enabled*.

Information:

To slightly improve the real-time behavior (jitter) of Automation Runtime Windows (ARwin) with a graphics-heavy application, BIOS settings *Advanced - Graphics (IGD) configuration - IGD turbo* and *Advanced - Graphics (IGD) configuration - RC6 (render standby)*⁵⁾ can be set to *Disabled*.

If the BIOS setting *Advanced - Graphics (IGD) Configuration - IGD Turbo* is set to *Disabled*, the graphics performance of the system is noticeably reduced.

7.3.6.5 Licensing

B&R Automation Runtime software components are subject to licensing. It is possible to choose between the following licensing types:

- **Hardware-based:**
The license information is stored on a USB dongle (Technology Guard) that is connected to a free USB interface.
- **Software-based (Automation Studio V4.9 or later):**
The license information is stored as a software package directly on the target system.
- **Contract-based (Automation Studio V4.9 or later):**
Terms and conditions.

For detailed information about licensing, see Automation Help (**Automation software / Licensing**).

⁴⁾ For BIOS versions 1.40 and later: *RC6 (render standby)* is automatically disabled when *Realtime environment* is enabled.

⁵⁾ For BIOS versions 1.40 and later: *RC6 (render standby)* is automatically disabled when *Realtime environment* is enabled.

7.3.7 B&R Hypervisor

B&R Hypervisor allows multiple operating systems to operate simultaneously on a single device. The operating systems can communicate with each other via a virtual network.

Intelligent distribution of CPU resources

B&R Hypervisor allows Windows or Linux to run simultaneously with Automation Runtime. This makes it possible to combine a controller and HMI PC in one device. With B&R Hypervisor, an industrial PC can also be used as an edge controller. This serves as a controller and simultaneously transmits pre-processed data to higher-level systems in the cloud via OPC UA.



Virtual network

The hypervisor provides a virtual network connection that allows applications to exchange data between operating systems. Similar to an ordinary Ethernet interface, standard network protocols are used. In place of a cable, there is a reserved memory area that is not allocated to either operating system.

Maximum flexibility

The user configures the hypervisor and allocates hardware resources in the B&R Automation Studio software development environment. The system configurations are determined individually. This makes the assignment of resources to the respective operating system flexible. Whereas previous simultaneous solutions were tailored to a specific Windows version, B&R Hypervisor is completely independent of the version of the operating systems used.

System requirements

The following minimum software versions are required to operate B&R Hypervisor on the Automation PC 2100:

- ARemb upgrade AR F4.44
- Automation Studio V4.4
- APC2100 BIOS V1.40
- APC2100 MTCX V1.13

Information:

To operate B&R Hypervisor, settings *Advanced - Miscellaneous configuration - Realtime environment and Hypervisor environment* must be set to *Enabled*.

Information:

For detailed information, see Automation Help or the B&R website (www.br-automation.com).

7.3.8 mapp Technology

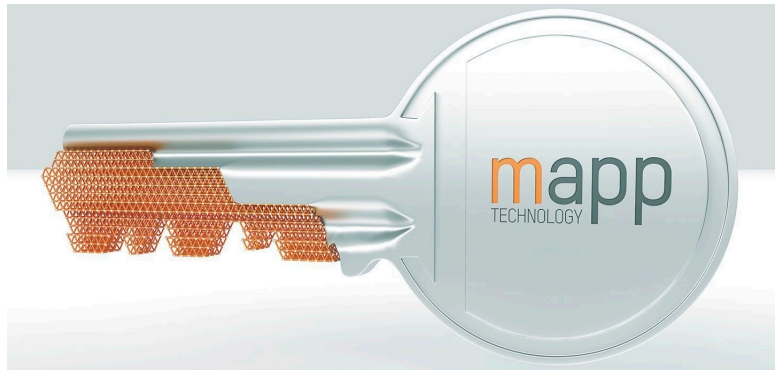

mapp Technology is revolutionizing the creation of machine and plant software. "mapps" are as easy to use as smartphone apps. Instead of programming user/role systems, alarm systems or the control of axes line by line, the machine software developer simply configures the finished mapps. Complex algorithms are easy to master. The programmer can concentrate fully on the machine process.

Information:

For detailed information, see Automation Help or the B&R website (www.br-automation.com).

7.3.9 Linux for B&R 8 (GNU/Linux)

7.3.9.1 General information

Information:

Security updates, hotfixes, free or paid support and technical resources will no longer be offered after June 30, 2020.

Linux or GNU/Linux are usually free, UNIX-like multi-user operating systems based on the Linux kernel and fundamentally on GNU software. Wide (also commercial) distribution was made possible starting in 1992 by licensing the Linux kernel under the GPL.

The Linux version created by B&R is based on Debian 8. It already contains all the drivers required for the respective device and can therefore be used immediately without any additional effort.

Advantages of Debian:

- High stability
- Large package selection

For more information about Debian, see <http://www.debian.org>.

7.3.9.2 Order data

Order number	Short description	Figure
	Linux for B&R 8	
5SWLIN.0542-MUL	Linux for B&R 8 - 32-bit - Multilingual - APC2100 Bay Trail chipset - Installation - Only available with a new device	
5SWLIN.0642-MUL	Linux for B&R 8 - 64-bit - Multilingual - APC2100 Bay Trail chipset - Installation - Only available with a new device	
	Optional accessories	
	CFast cards	
5CFAST.016G-00	CFast 16 GB SLC	
5CFAST.032G-00	CFast 32 GB SLC	
5CFAST.032G-10	CFast 32 GB MLC	
5CFAST.064G-10	CFast 64 GB MLC	
5CFAST.128G-10	CFast 128 GB MLC	
5CFAST.4096-00	CFast 4 GB SLC	
5CFAST.8192-00	CFast 8 GB SLC	

7.3.9.3 Overview

Order number	5SWLIN.0542-MUL	5SWLIN.0642-MUL
Operating system		
Target systems		
Industrial PC	APC2100	
Chipset	Bay Trail	
Architecture	32-bit	64-bit
Language	Multilingual	
Minimum size of RAM	1 GB	
Minimum size of data storage medium	4 GB	

7.3.9.4 Features

- LXDE desktop
- Touch screen driver
- MTCX driver
- ADI library
- HMI diagnostics tool
- Tool for right-click support via touch screen
- Virtual keyboard

Detailed instructions about Linux for B&R 8 can be downloaded from the Downloads section of the B&R website (www.br-automation.com).

7.3.9.5 Installation

Linux for B&R 8 is preinstalled by B&R on the desired data storage medium (e.g. CFast card). All necessary drivers (graphics, network, etc.) for operation are also installed.

Debian 8 can also be downloaded from the Debian website (<http://www.debian.org>) and installed separately. Instructions are also available on the Debian website.

Notes regarding special features of installation on B&R devices are described in a separate document that can be downloaded from the B&R website (www.br-automation.com).

Installation packages are available for the necessary B&R adjustments; these can also be downloaded from the B&R website (www.br-automation.com).

7.3.9.6 Drivers

The operating system contains all drivers necessary for operation.

The current version of B&R-specific drivers can be downloaded and installed from the B&R website (www.br-automation.com).

7.3.10 Linux for B&R 9 (GNU/Linux)

7.3.10.1 General information

Information:

Security updates, hotfixes, free or paid support and technical resources will no longer be offered after June 30, 2022.

Reasons for Debian:

- High stability
- Large package selection
- Wide distribution of Debian and various derivatives (e.g. Ubuntu, Linux Mint)

For additional information, see the Debian website (<https://www.debian.org/>).

Information:

For detailed information, see the user's manual of the operating system. This is available for download on the B&R website (www.br-automation.com).

7.3.10.2 Order data

Order number	Short description	Figure
	Linux for B&R 9	
5SWLIN.0742-MUL	Linux for B&R 9 - 64-bit - Multilingual - APC2100 Bay Trail chipset - Installation - Only available with a new device	
	Optional accessories	
	CFast cards	
5CFAST.016G-00	CFast 16 GB SLC	
5CFAST.032G-00	CFast 32 GB SLC	
5CFAST.032G-10	CFast 32 GB MLC	
5CFAST.064G-10	CFast 64 GB MLC	
5CFAST.128G-10	CFast 128 GB MLC	
5CFAST.256G-10	CFast 256 GB MLC	
5CFAST.4096-00	CFast 4 GB SLC	
5CFAST.8192-00	CFast 8 GB SLC	

7.3.10.3 Overview

Order number	5SWLIN.0742-MUL
Operating system	
Target systems	
Industrial PC	APC2100
Chipset	Bay Trail
Architecture	64-bit
Language	Multilingual
Minimum size of RAM	1 GB
Minimum size of data storage medium	4 GB

7.3.10.4 Features

- LXDE desktop
- Touch screen support
- MTCX driver
- ADI library
- Tool for right-click support via touch screen
- Virtual keyboard

Detailed instructions about Linux for B&R 9 can be downloaded from the Downloads section of the B&R website (www.br-automation.com).

7.3.10.5 Installation

Linux for B&R 9 is preinstalled on the desired data storage medium (e.g. CFast card).

7.3.10.6 Drivers

The operating system contains all drivers necessary for operation.

The current version of B&R-specific drivers can be downloaded and installed from the B&R website (www.br-automation.com).

7.4 Automation Device Interface (ADI)

The Automation Device Interface (ADI) allows access to specific functions of B&R devices in Windows and Linux.

7.4.1 ADI Control Center

The settings of B&R devices can be read out and changed in Windows using the ADI Control Center in the Control Panel. The figure shown is a symbolic image; the representation may vary depending on the device.

Information:

The displayed temperature and voltage values (e.g. CPU temperature, core voltage, battery voltage) represent uncalibrated information values. No conclusions about possible alarms or hardware malfunctions can be drawn from this. The hardware components used have automatic diagnostic functions in the event of error.

Module	Sensor	°C	°F	Alarm
System Unit	1	25.00	77.00	
System Unit	2	28.00	82.40	
System Unit	3	35.00	95.00	
System Unit	4	29.00	84.20	
IF Module 3	1	45.50	113.90	
IF Module 1	1	24.00	75.20	
Panel 0	1	30.00	86.00	
Panel 8	1	28.50	83.30	
CPU		29.00	84.20	
LPS	Battery	24.00	75.20	

7.4.1.1 Functions

The ADI Control Center offers the following functions, for example:

- Changing display-specific parameters
- Reading out device-specific keys
- Updating the key configuration
- Testing keys or device-specific LEDs of a membrane keypad
- Reading out or calibrating control devices (e.g. key switch, handwheel, joystick, potentiometer)
- Reading out temperatures, fan speeds, switch positions and statistical data
- Reading out operating hours (power-on hours)
- Reading user settings and factory settings
- Reading out software versions
- Updating and backing up BIOS and firmware
- Creating reports for the current system (support)
- Setting the SDL equalizer value for the SDL cable adjustment
- Changing the user serial ID

For a detailed description, see the user documentation for the ADI driver.

Information:

The functions available in the ADI Control Center depend on the device family.

7.4.1.2 Installation

The ADI driver is included in most B&R Windows operating systems or can be installed on request.

The ADI driver (also includes the ADI Control Center) and user documentation can be downloaded at no cost from the Downloads section of the B&R website (www.br-automation.com). If a more recent version is available, it can be installed later.

Information:

The *Write filter* must be disabled during installation.

7.4.2 ADI Development Kit (Windows)

This software allows *ADI* functions to be accessed from Windows applications created with Microsoft Visual Studio, for example:

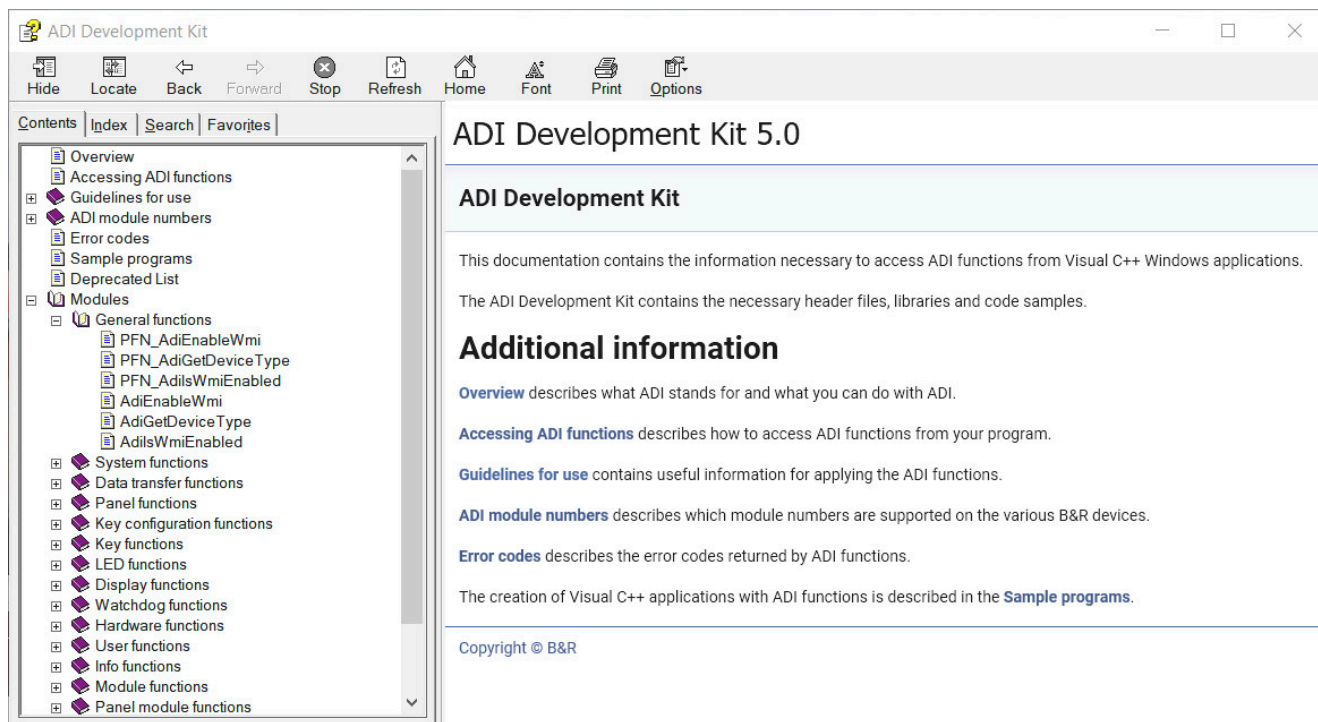

Features:

- Header files and import libraries
- Help files (in English)
- Example projects
- ADI DLL: For testing applications if no ADI driver is installed.

The appropriate ADI driver must be installed for the device. The ADI driver is already included in B&R images of embedded operating systems.

For a detailed description of how to use ADI functions, see Automation Help.

The ADI Development Kit can be downloaded at no cost from the Downloads section of the B&R website (www.br-automation.com).

7.4.3 ADI .NET SDK (Windows)

This software allows *ADI* functions to be accessed from .NET applications created with Microsoft Visual Studio.

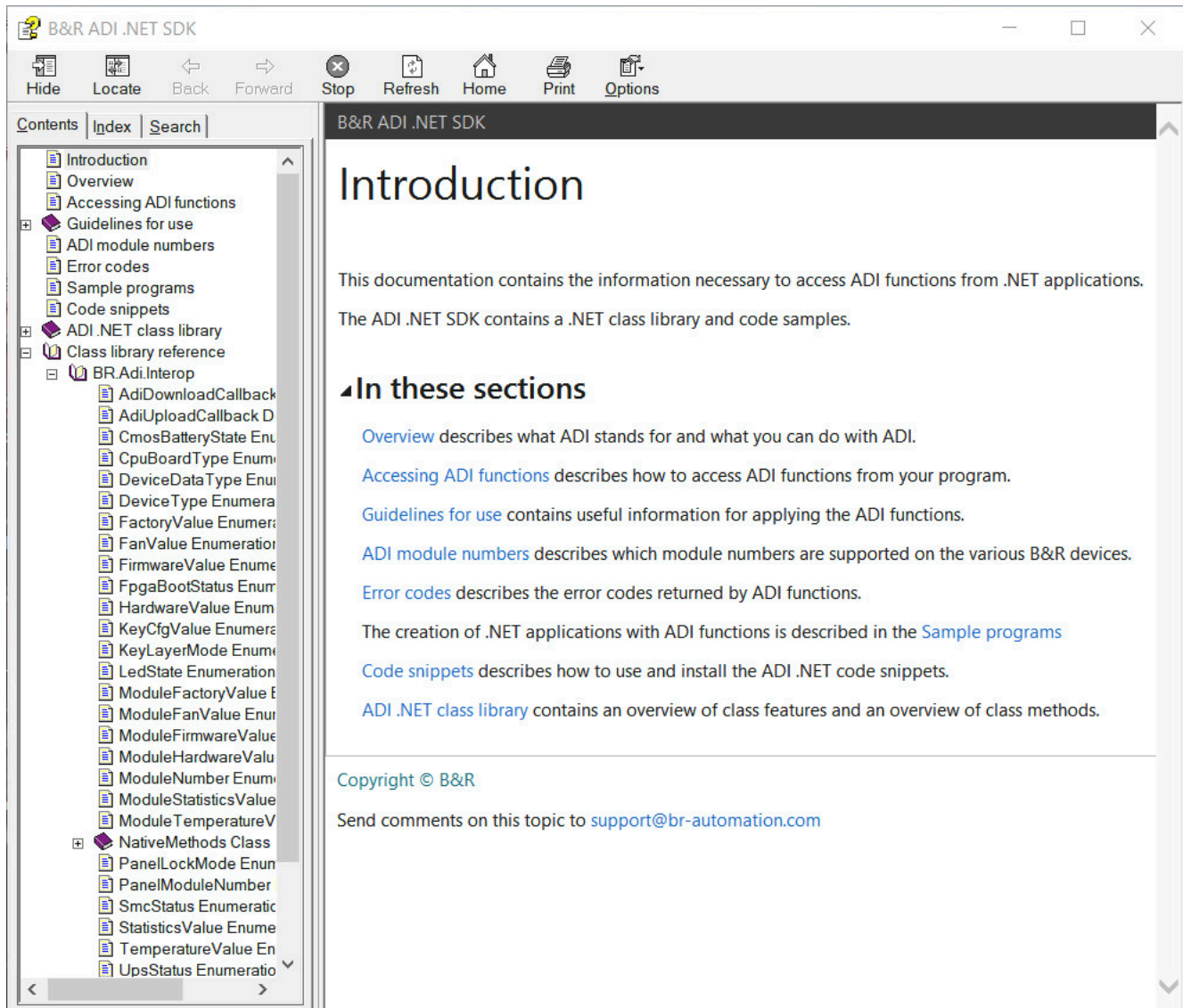

Features:

- ADI .NET class library
- Help files (in English)
- Example projects
- ADI DLL: For testing applications if no ADI driver is installed.

The appropriate ADI driver must be installed for the device. The ADI driver is already included in B&R images of embedded operating systems.

For a detailed description of how to use ADI functions, see Automation Help.

The ADI .NET SDK can be downloaded at no cost from the Downloads section of the B&R website (www.br-automation.com).

7.5 Key Editor

A frequently occurring requirement for panels is adapting function keys and LEDs to the application software. With the Key Editor, individual adaptation to the application is possible quickly and easily.

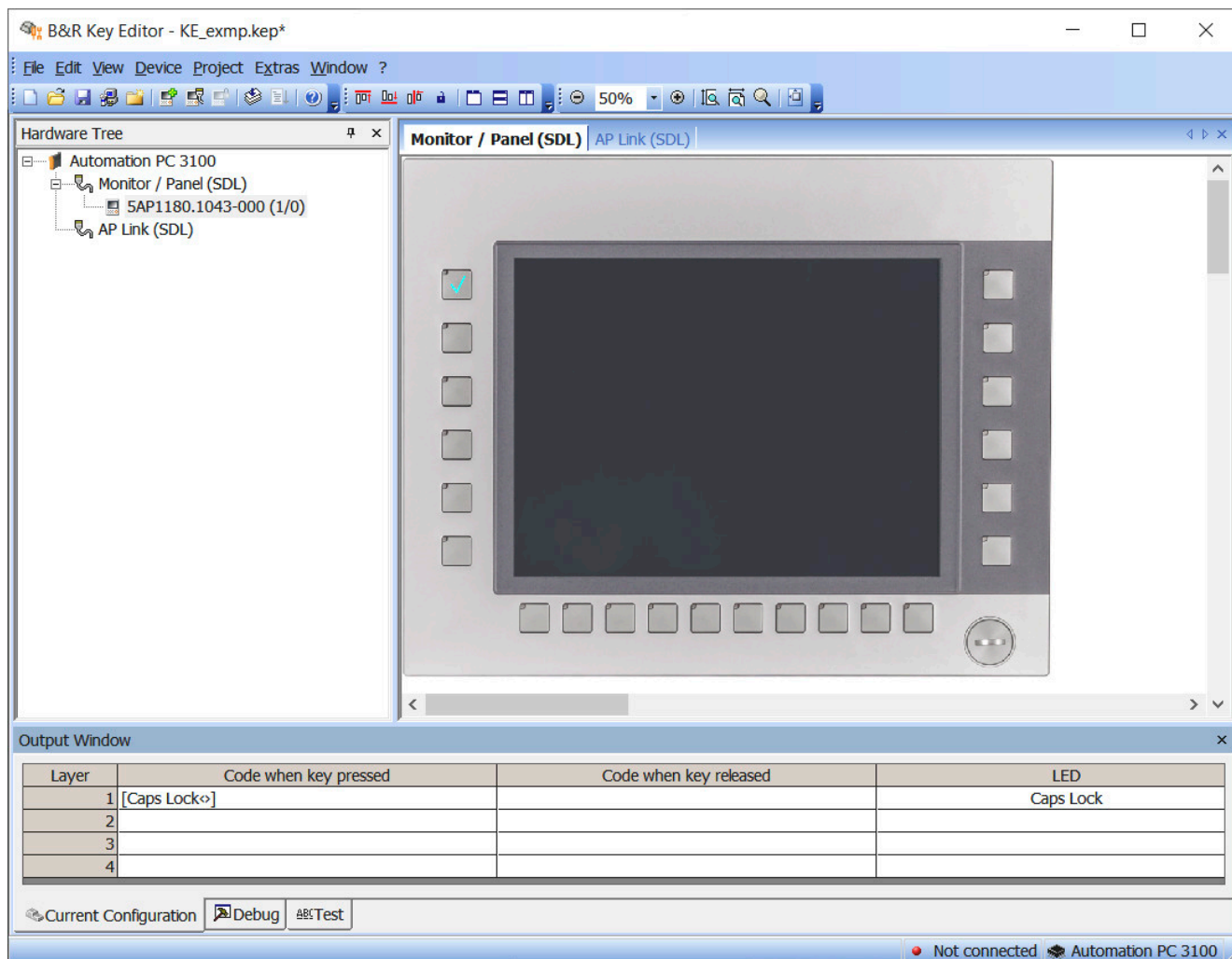

Features:

- Configuration of normal keys like on a keyboard (A, B, C, etc.)
- Keyboard shortcuts (CTRL+C, SHIFT+DEL, etc.) on one key
- Special key functions (change brightness, etc.)
- Assignment of LED functions (HDD access, power, etc.)
- 4 assignments possible per key (using layers)
- Configuration of the panel lock time when connecting several Automation Panel devices to Automation PCs and Panel PCs

For detailed instructions about configuring keys and LEDs and installing the key configuration on the target system, see the help documentation for the Key Editor. The Key Editor and help documentation can be downloaded at no cost from the Downloads section of the B&R website (www.br-automation.com).

7.6 KCF Editor

The KCF Editor can be used as a simple alternative to the Key Editor. It can also be used to adapt function keys and LEDs to the application software. In contrast to the Key Editor, operation does not take place using a graphical representation of the device, but via a simple Windows dialog box. The KCF Editor can therefore also be used for devices that are not yet supported in the Key Editor. The KCF Editor is a "portable" application and can be started directly from a USB flash drive without installation on the target device, for example.

An installed ADI driver is required for the full range of functions.

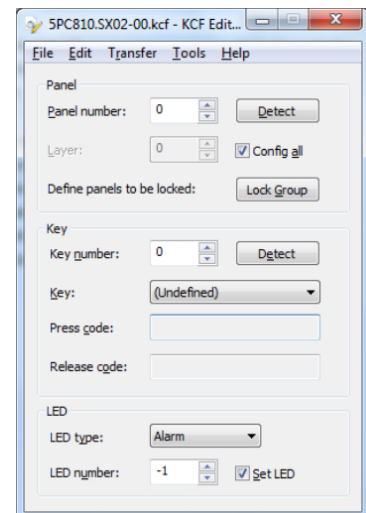

Features:

- Configuration of normal keys like on a keyboard (A, B, C, etc.)
- Special key functions (change brightness, etc.)
- Assignment of LED functions (HDD access, power, etc.)
- 4 assignments possible per key (using layers)
- Configuration of the panel lock time when connecting several Automation Panel devices to B&R PCs.
- Export and import of the configuration (via INI files)
- Save configuration as report (text file)

If the KCF Editor is running on the target device and the ADI driver is installed, the following additional features are available:

- Panel and key detection
- LED test
- Download/Upload the configuration

For detailed instructions about configuring keys and LEDs and installing the key configuration on the target system, see the user documentation for the KCF Editor. The KCF Editor and user documentation can be downloaded at no cost from the Downloads section of the B&R website (www.br-automation.com).

7.7 HMI Service Center

The HMI Service Center is software for testing B&R industrial PCs and Automation Panels. Testing covers different categories such as COM, network and SRAM (see "Test overview" on page). This document describes the use of version 3.0.0 and newer of the HMI Service Center.

Up to version 2.0.0, the HMI Service Center was a paid product and could be ordered with material number 5SWUTI.0001-000. The HMI Service Center was delivered preinstalled on a USB flash drive.

Since version 3.0.0, the HMI Service Center is available as a download at no cost and can be installed on any USB flash drive with the HMI Service Center Maintenance tool.

For more detailed information, the HMI Service Center user's manual can be downloaded from the [B&R website \(https://www.br-automation.com\)](https://www.br-automation.com).

7.7.1 5SWUTI.0001-000

7.7.1.1 General information

The HMI Service Center is software for testing B&R industrial PCs and Automation Panels. Testing covers different categories such as COM, network and SRAM.

The test system consists of a USB flash drive with installed Windows PE operating system and the HMI Service Center.

For details about the HMI Service Center, see the HMI Service Center user's manual. This can be downloaded at no cost from the B&R website (www.br-automation.com).

7.7.1.2 Order data

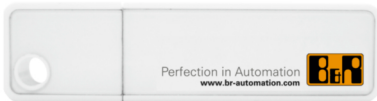
Order number	Short description	Figure
	Accessories	
5SWUTI.0001-000	HMI Service Center USB flash drive - Hardware diagnostic software - For APC910/PPC900 - For PPC1200 - For APC2100/PPC2100 - For APC2200/PPC2200 - For APC3100/PPC3100 - For APC mobile - For AP800/AP900 - For AP9x3/AP9xD - For AP1000/AP5000	

8 Maintenance

The following chapter describes the maintenance work that can be carried out by a qualified and trained end user.

Information:

Only components approved by B&R are permitted to be used for maintenance work.

8.1 Repairs/Complaints and replacement parts

Danger!

Unauthorized opening or repair of a device may result in personal injury and/or serious damage to property. Repairs are therefore only permitted to be carried out by authorized qualified personnel at the manufacturer's premises.

To process a repair/complaint, a repair order or complaint must be created via the B&R Material Return Portal on the B&R website (www.br-automation.com).

8.2 Replacing CFast cards

Caution!

CFast cards are only permitted to be inserted and removed in a voltage-free state!

Improper handling of the ejection lever (e.g. applying a large amount of force) can result in a defect in the ejector mechanism.

The CFast card can be exchanged quickly and easily by pressing the ejector (see figure) with a pointed object (e.g. ballpoint pen).

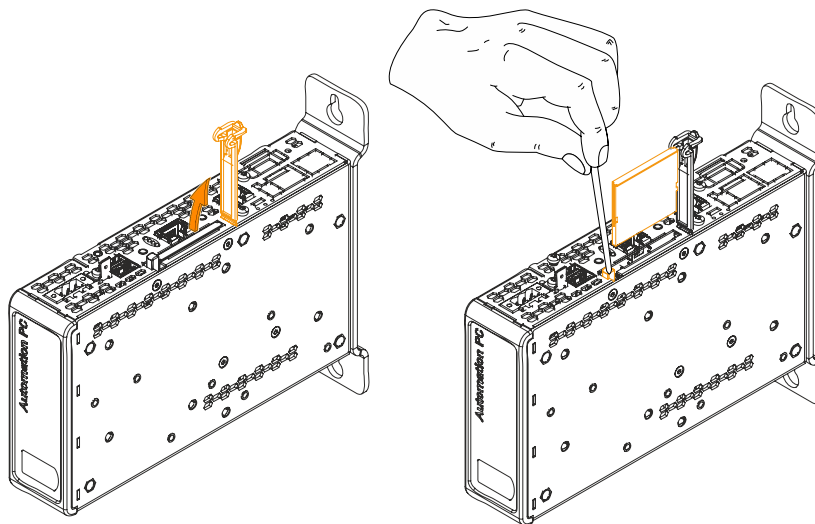

9 International and national certifications

9.1 Directives and declarations

9.1.1 CE marking



All directives applicable to the respective product and their harmonized EN standards are met.

9.1.2 EMC Directive

The products meet the requirements of EU directive "Electromagnetic compatibility 2014/30/EU" and are designed for industrial applications:

EN 61131-2:2007	Programmable controllers - Part 2: Equipment requirements and tests
EN 61000-6-2:2005	Electromagnetic compatibility (EMC) - Part 6-2: Generic standards - Immunity for industrial environments
EN 61000-6-4:2007	Electromagnetic compatibility (EMC) - Part 6-4: Generic standards - Emission standard for industrial environments

Information:

Declarations of conformity are available on the B&R website under [Downloads > Certificates > Declarations of conformity](#).

9.2 Certifications

Danger!

A complete system can only receive certification if all individual components installed and connected in it have the corresponding certifications. If an individual component is used that does not have the corresponding certification, the complete system will also not be certified.

B&R products and services comply with applicable standards. These are international standards from organizations such as ISO, IEC and CENELEC, as well as national standards from organizations such as UL, CSA, FCC, VDE, ÖVE, etc. We pay special attention to the reliability of our products in the industrial sector.

Information:

The certifications valid for the respective product are available on the website and in the user's manual under the technical data in section "Certifications" or in the associated certificates.

9.2.1 UL certification



Products with this mark are tested by Underwriters Laboratories and listed as "industrial control equipment". The mark is valid for the USA and Canada and simplifies the certification of your machines and systems in this economic area.

Underwriters Laboratories (UL) per standard UL 508
Canadian (CSA) standard per C22.2 no. 142-M1987

UL certificates are available on the B&R website under [Downloads > Certificates > UL](#).

Ind. Cont. Eq.
E115267

The device is classified as "open type" for use in the area of "Industrial control equipment" sector per UL 508. The device must therefore be installed in a UL 508-compliant protective housing as a requirement for certification or operation per UL 508.

9.2.2 KC



Products with this mark are tested by an accredited test laboratory and permitted to be introduced into the Korean market (based on EU conformity).

9.2.3 UKCA



UK Conformity Assessed (UKCA)

All directives applicable to the respective product and their relevant standards are met. Products with this marking are permitted to be imported into Great Britain (England, Wales, Scotland).

Information:

Declarations of conformity are available on the B&R website under [Downloads > Certificates > Declarations of conformity](#).

9.2.4 RCM



Products with this mark are tested by an accredited test laboratory and certified by the ACMA. The mark is valid for Australia/Oceania and simplifies the certification of your machines and systems in this economic area (based on EU conformity).

9.2.5 DNV certification



Products with this certification are certified by the classification society DNV and suitable for the maritime sector. DNV certificates (type approvals) are generally accepted by other classification societies during ship acceptance procedures. Products used on a ship's bridge must be dimmable using software in accordance with the regulations and guidelines from the respective classification society.

Windows 7 operating systems are only permitted to be used as embedded variants. There are no limitations for all other operating systems approved by B&R.

DNV certificates with specifications for permissible environmental conditions as well as a list of revisions from which the DNV type certification applies to individual devices are available on the B&R website ([Downloads > Certificates > Maritime](#)).

9.2.6 UL Haz. Loc. certification



Ind. Cont. Eq.
for Haz.Loc.
Cl. I, Div. 2,
Groups ABCD
E180196 (T4)

Products with this mark are tested by Underwriters Laboratories and listed as "industrial control equipment for use in hazardous locations". The mark is valid for the USA and Canada and simplifies the certification of your machines and systems in this economic area.

Underwriters Laboratories (UL) per standard ANSI/ISA 12.12.01
Canadian (CSA) standard per C22.2 no. 213-16

The UL HazLoc certificates are available on the B&R website ([Downloads > Certificates > HazLoc](#)).

9.2.6.1 General safety guidelines

APC2100 systems that are certified for use in potentially explosive environments and carry the marking above are suitable for use in Class 1, Division 2, Groups A, B, C and D or in nonexplosive environments and correspond to the following standards: UL Std. 508 - 17th Edition, ANSI/ISA 12.12.01:2015, CSA Std. C22.2 No. 213-16.

9.2.6.2 Mounting and installation

Devices with explosion protection are to be used as intended and are only permitted to be operated by knowledgeable and qualified personnel according to these operating instructions and the additional information contained in the user's manual. Operation in any other way endangers the safety and functionality of the devices and connected systems. The operator is responsible for observing all applicable safety regulations, accident prevention regulations and standards.

Devices must be installed in a suitable protective housing that can only be opened with the assistance of a tool. In order to ensure sufficient air circulation, the specified clearance values must be observed. Usage is only permitted in environments with pollution degree 2. The maximum ambient temperature varies depending on the individual components being used, see section "[Temperature specifications](#)" on page 29.

Before any installation or use of a device in potentially explosive atmospheres, the certification mark on the device must be checked. Additional equipment must be suitable for the place of use. Final assembly must be approved by the responsible local authorities. Wiring must be carried out in accordance with national regulations and the requirements of the authorities.

Devices must remain voltage-free until installation work is completed. The tightening torque for the power supply terminals is 0.5 Nm. Cables must be suitable for a surface temperature of 75°C. APC2100 systems are only permitted to be operated with 24 VDC.

Unshielded/Ungrounded cables are not permitted to be used in potentially explosive atmospheres under any circumstances. Devices must be securely connected to the potential equalization terminal. Power supply, communication and accessory cables must be secured on the device or control cabinet. Power supply, communication and accessory cables are not permitted to exert excessive strain on connections. This must take into account possible vibrations in the area.

9.2.6.3 Operation

To switch APC2100 systems on/off in a potentially explosive atmosphere, either a switch must be located outside the potentially explosive atmosphere or a switch certified for use in potentially explosive atmospheres must be used.

Danger!

Risk of explosion: Accessories are not permitted to be connected or disconnected when the power is switched on unless the area is considered nonhazardous and is free of ignitable concentrations!

Risk of explosion: Replacing components may impair eligibility for Class I, Division 2!

Danger !

Risque d'explosion – Ne pas connecter ou déconnecter un quelconque équipement lorsque le circuit est sous tension, à moins que la zone soit connue comme étant sans risque et sans concentrations inflammables!

Risque d'explosion – Le remplacement de composants peut compromettre l'aptitude au respect de la Classe I, Division 2!

With the exception of USB dongle OTG1000.01 or in accordance with the requirements listed in "[USB connection with the Automation PC 2100](#)" and "[USB connection with the 4-port hub](#)", USB interfaces are not certified for operation in potentially explosive areas and are only permitted to be used for service purposes.

9.2.6.4 Servicing, disturbances and removal

Devices must be switched off and protected against accidental startup. A suitable voltmeter must be used to check that the power supply has been cut off.

Before removing or installing accessories, components or cables, the power supply to APC2100 systems and power supplies must be disconnected. Defective devices are only permitted to be replaced by knowledgeable and qualified personnel. Before switching on or connecting to the power supply, all covers and system components must be reinstalled and secured.

Danger!

Failure to follow this instruction can result in death, serious bodily injury or damage to property!

Danger !

Le non-respect de ces instructions peut entraîner des blessures graves ou mortelles!

9.2.6.5 USB connection with the Automation PC 2100

9.2.6.5.1 Introduction

The information below describes the use of USB peripheral devices on USB interfaces 1 and 2 of the B&R Automation PC 2100 in hazardous locations Class I, Division 2, Groups A, B, C and D.

Danger!

RISK OF EXPLOSION

- Before installation or use in potentially explosive atmospheres, the explosion protection class of the device must be checked according to ANSI/ISA 12.12.01 and CSA C22.2 N°213.
- To switch on/off B&R devices that are installed in potentially explosive atmospheres, at least one of the following conditions must be met:
 - A suitable switch installed outside the hazardous area is used.
 - A switch certified according to the hazardous location class and division for *tube use* is used.
- As long as the electrical circuit is activated, cables or lines are not permitted to be connected or disconnected unless the area is knowingly free of flammable concentrations of vapors, gases and other flammable or combustible materials. This applies to all connections and circuits. This includes power, ground and network connections as well as series and parallel connections.
- Unshielded/Ungrounded cables are never permitted to be used in potentially explosive atmospheres.
- Only configurations with nonincendive USB devices are permitted to be used.
- The doors and openings of housings must always remain closed. This prevents the accumulation of foreign bodies within the workstation.

Failure to follow this instruction can result in death, serious bodily injury or damage to property!

9.2.6.5.2 Description

Nonincendive devices (keyboards, mouse) are certified for use on the rear USB interfaces of the B&R Automation PC 2100 (connected device) and are permitted to be connected and disconnected during operation. In addition to the nonincendive property, devices that can be connected to rear USB interfaces 1 and 2 must meet the following criteria.

The figure shows a wiring diagram of the USB cable:

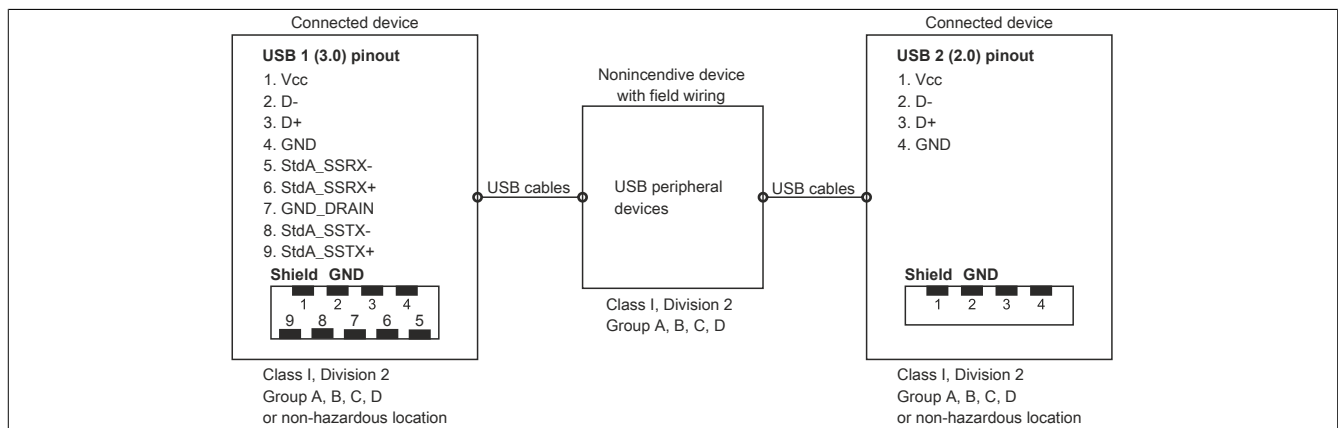

The following tables indicate the nonincendive electrical circuit parameters:

Interface USB1 (USB 3.0):	
No-load voltage [V_{oc}]	5.13 V
Short circuit current [I_{sc}]	2060 mA
Associated capacitance [C_a]	20 μ F
Associated inductance [L_a]	4.8 μ H
Interface USB2 (USB 2.0):	
No-load voltage [V_{oc}]	5.13 V
Short circuit current [I_{sc}]	2060 mA
Associated capacitance [C_a]	20 μ F
Associated inductance [L_a]	4.8 μ H

The unit concept allows the interconnection of nonincendive devices with connected devices with non-specifically tested combinations as a system. For this purpose, the permissible values of V_{oc} (or U_o) and I_{sc} (or I_o) for the connected device must be less than or equal to V_{max} (U_i) and I_{max} (I_i) for the nonincendive device, the permissible values of C_a (C_o) and L_a (L_o) for the connected device must be greater than or equal to $C_i + C_{Cable}$ and $L_i + L_{Cable}$ for the nonincendive device with field wiring.

The nonincendive device with field wiring must meet the following criteria:

B&R device (connected device)	-	Connected, nonincendive device with field wiring (mouse, keyboard)
V_{oc}	\leq	V_{max}
I_{sc}	\leq	I_{max}
C_a	\geq	$C_i + C_{Cable}$
L_a	\geq	$L_i + L_{Cable}$

If the electrical parameters of the cable are unknown, the following values can be used:

Where $C_{Cable} = 196.85$ pF/m (60 pF/ft) if unknown

Where $L_{Cable} = 0.656$ μ H/m (0.20 μ H/ft) if unknown

Wiring must be carried out in accordance with national regulations and the requirements of the authorities.

The B&R device must be installed in a suitable protective housing. For installations in Class I, Division 2 hazardous locations, the housing must be capable of withstanding one or more Division 2 wiring methods.

Warning!

- Replacing components may impair the suitability of the Division 2 hazardous location (classified) under certain circumstances.
- As long as the area is knowingly at risk of explosion, the device is not permitted to be switched on or off.
- The nonincendive device with field wiring is not permitted to be connected via a parallel connection. This is valid unless the device has received express permission for this.

The B&R device is suitable for use in Class I, Division 2, Groups A, B, C and D areas. It also provides nonincendive field wiring for devices in Class I, Division 2, Groups A, B, C and D.

9.2.6.6 USB connection with the 4-port hub

9.2.6.6.1 Introduction

The information below describes the use of USB peripheral devices for the B&R 4-port USB hub in hazardous locations Class I, Division 2, Groups A, B, C and D.

Danger!

RISK OF EXPLOSION

- Before installation or use in potentially explosive atmospheres, the explosion protection class of the device must be checked according to ANSI/ISA 12.12.01 and CSA C22.2 N°213.
- To switch on/off B&R devices that are installed in potentially explosive atmospheres, at least one of the following conditions must be met:
 - A suitable switch installed outside the hazardous area is used.
 - A switch certified according to the hazardous location class and division for *tube use* is used.
- As long as the electrical circuit is activated, cables or lines are not permitted to be connected or disconnected unless the area is knowingly free of flammable concentrations of vapors, gases and other flammable or combustible materials. This applies to all connections and circuits. This includes power, ground and network connections as well as series and parallel connections.
- Unshielded/Ungrounded cables are never permitted to be used in potentially explosive atmospheres.
- Only configurations with nonincendive USB devices are permitted to be used.
- The doors and openings of housings must always remain closed. This prevents the accumulation of foreign bodies within the workstation.

Failure to follow this instruction can result in death, serious bodily injury or damage to property!

9.2.6.6.2 Description

Nonincendive devices (keyboards, mouse) are certified for use on the B&R 4-port hub (connected device) and are permitted to be connected and disconnected during operation. In addition to the nonincendive property, devices that can be connected to the USB interfaces must meet the following criteria.

The figure shows a wiring diagram of the USB cable:

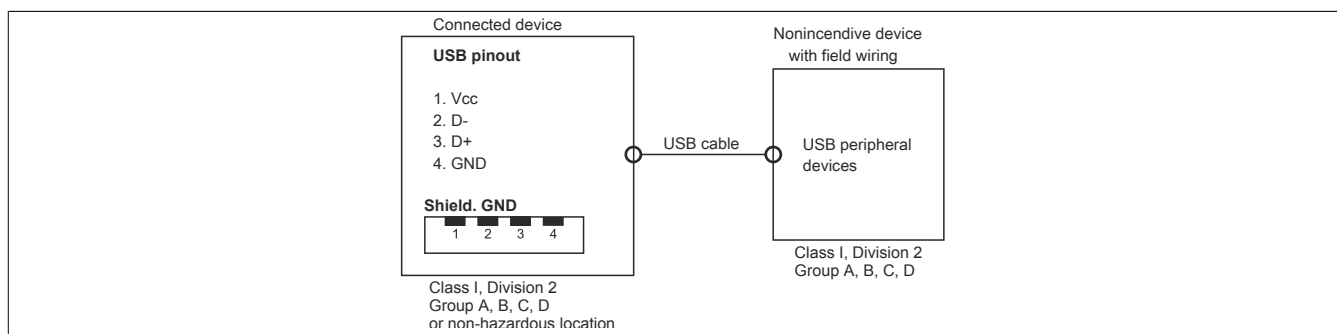

The following table shows the nonincendive circuit parameters of the 4-port hub USB interfaces:

USB interfaces (USB 2.0):	
No-load voltage [V_{oc}]	5.11 V
Short circuit current [I_{sc}]	1621 mA
Associated capacitance [C_a]	20 μ F
Associated inductance [L_a]	16.8 μ H

The unit concept allows the interconnection of nonincendive devices with connected devices with non-specifically tested combinations as a system. For this purpose, the permissible values of V_{oc} (or U_o) and I_{sc} (or I_o) for the connected device must be less than or equal to V_{max} (U_i) and I_{max} (I_i) for the nonincendive device, the permissible values of C_a (C_o) and L_a (L_o) for the connected device must be greater than or equal to $C_i + C_{Cable}$ and $L_i + L_{Cable}$ for the nonincendive device with field wiring.

The nonincendive device with field wiring must meet the following criteria:

B&R device (connected device)	-	Connected, nonincendive device with field wiring (mouse, keyboard)
V_{oc}	\leq	V_{max}
I_{sc}	\leq	I_{max}
C_a	\geq	$C_i + C_{cable}$
L_a	\geq	$L_i + L_{cable}$

If the electrical parameters of the cable are unknown, the following values can be used:

Where $C_{Cable} = 196.85 \text{ pF/m}$ (60 pF/ft) if unknown

Where $L_{Cable} = 0.656 \text{ }\mu\text{H/m}$ (0.20 $\mu\text{H/ft}$) if unknown

Wiring must be carried out in accordance with national regulations and the requirements of the authorities.

The B&R device must be installed in a suitable protective housing. For installations in Class I, Division 2 hazardous locations, the housing must be capable of withstanding one or more Division 2 wiring methods.

Warning!

- Replacing components may impair the suitability of the Division 2 hazardous location (classified) under certain circumstances.
- As long as the area is knowingly at risk of explosion, the device is not permitted to be switched on or off.
- The nonincendive device with field wiring is not permitted to be connected via a parallel connection. This is valid unless the device has received express permission for this.

The B&R device is suitable for use in Class I, Division 2, Groups A, B, C and D areas. It also provides nonincendive field wiring for devices in Class I, Division 2, Groups A, B, C and D.

9.2.7 American Bureau of Shipping (ABS)



Products with this certification are suitable for use in the maritime sector according to the regulations of the classification society American Bureau of Shipping (ABS Rules).

Certificates with specifications for permissible environmental conditions as well as a list of revisions from which the certification applies to individual devices are available on the B&R website ([Downloads > Certificates > Maritime](#)).

9.2.8 Bureau Veritas (BV)



Products with this certification are suitable for use in the maritime sector according to the regulations of the classification society Bureau Veritas (BV).

Certificates with specifications for permissible environmental conditions as well as a list of revisions from which the certification applies to individual devices are available on the B&R website ([Downloads > Certificates > Maritime](#)).

9.2.9 Lloyd's Register (LR)



Products with this certification are suitable for use in the maritime sector according to the regulations of the classification society Lloyd's Register (LR).

Certificates with specifications for permissible environmental conditions as well as a list of revisions from which the certification applies to individual devices are available on the B&R website ([Downloads > Certificates > Maritime](#)).

9.2.10 Korean Register of Shipping (KR)



Products with this certification are suitable for use in the maritime sector according to the regulations of the classification society Korean Register of Shipping (KR).

Certificates with specifications for permissible environmental conditions are available on the B&R website ([Downloads > Certificates > Maritime](#)).

10 Accessories

The following accessories have undergone functional testing by B&R in connection with the device used and can be operated with this device. Possible limitations regarding operation with individual components other than the complete system must be taken into account, however. All individual specifications of the components must be observed when operating the complete system.

All components listed in this manual have undergone intensive system and compatibility testing and been approved accordingly. B&R cannot assume any functional warranty for accessories that have not been approved.

10.1 Cables

For additional information about compatible cables, see the B&R website ([HMI cable manual](#)).

10.2 USB mass storage device

For additional information about compatible USB mass storage devices, see the B&R website ([USB mass storage devices](#)).

10.3 General information

The following products can be used in the event of loss or for conversion or retrofitting.

10.3.1 Order data

Material number	Description
5ACCRHMI.0000-000	HMI grounding clip
5ACCRHMI.0001-000	Retaining clips 16 mm - 14 pcs. with 16 mm setscrews - For AP1000 and AP9x3
5ACCRHMI.0002-000	Retaining clips 20 mm - 14 pcs. with 20 mm setscrews - For AP1000 and AP9x3
5ACCRHMI.0003-000	Retaining clips 25 mm - 12 pcs. with 25 mm setscrews - For AP1000 and AP9x3
5ACCRHMI.0004-000	Rafi replacement key - 1 pc.
5ACCRHMI.0004-C00	Schlegel replacement key - 2 pcs.
5ACCRPC2.0000-000	PPC2100/2200 mounting screws kit - 4x screw M3x34 mm - 2x special screw for PPC2100
5ACCRPC2.0001-000	xPC2100/2200 interface covers - 1x cover set
5ACCRPC2.0007-000	APC2100/2200 front cover - Orange - With logo
5ACCRPC2.0008-000	APC2100/APC2200 front cover - Gray - With logo

10.4 Installation accessories

Suitable tool sets can be ordered to easily install B&R industrial PCs and converters.

- Consisting of:

5ACCRHMI.0006-000

- 1x torque screwdriver: 0.4 to 2.0 Nm
- 1x bit set (5 pieces): Hex recess (2.5 mm, 3.0 mm, 5.0 mm), Torx (T10, T20)

10.4.1 Order data

Order number	Short description	Figure
	Other	
5ACCRHMI.0006-000	HMI installation tool for control cabinet - 1x torque wrench 0.4 - 2.0 Nm - 1x hex head bit 2.5, length 89 mm - 1x hex head bit 3.0, length 89 mm - 1x hex head bit 5.0, length 89 mm - 1x Torx 10 bit, length 90 mm - 1x Torx 20 bit, length 89 mm	

10.5 Terminal block power supply

10.5.1 0TB103.9x

10.5.1.1 General information

One-row 3-pin terminal block 0TB103.9x is used for the power supply.

10.5.1.2 Order data

Order number	Short description	Figure
	Accessories	
0TB103.9	Connector 24 VDC - 3-pin, female - Screw clamp terminal block 3.31 mm ²	
0TB103.91	Connector 24 VDC - 3-pin, female - Cage clamp terminal block 3.31 mm ²	

10.5.1.3 Technical data

Information:

The following specified characteristic data, features and limit values are only valid for this accessory and may differ from those of the complete system. The data specified for the complete system applies to the complete system in which an accessory is used.

Order number	0TB103.9	0TB103.91
General information		
Certifications		
CE		Yes
UKCA		Yes
UL		cULus E115267 Industrial control equipment
HazLoc		cULus HazLoc E180196 Industrial control equipment for hazardous locations Class I, Division 2, Groups ABCD, T4
DNV		Temperature: B (0 to 55°C) Humidity: B (up to 100%) Vibration: A (0.7 g) EMC: B (bridge and open deck)
LR		ENV3
KR		Yes
ABS		Yes
BV		EC31B Temperature: 5 - 55°C Vibration: 0.7 g EMC: Bridge and open deck
EAC		Yes
Terminal block		
Note	Protected against vibration by the screw flange Nominal data per UL	
Number of pins	3 (female)	
Type of terminal block	Screw clamp terminal block variant	Cage clamp terminal block variant ¹⁾
Cable type	Only copper wires (no aluminum wires!)	
Pitch	5.08 mm	
Connection cross section		
AWG wire	26 to 14 AWG	26 to 12 AWG
Wire end sleeves with plastic covering	0.20 to 1.50 mm ²	
Single-wire	0.20 to 2.50 mm ²	
Fine-stranded wires	0.20 to 1.50 mm ²	0.20 to 2.50 mm ²
With wire end sleeves	0.20 to 1.50 mm ²	
Tightening torque	0.4 Nm	-
Electrical properties		
Nominal voltage	150 V	
Nominal current ²⁾	13 A / contact	15 A / contact
Contact resistance	≤5 mΩ	
Operating conditions		
Pollution degree per EN 61131-2	Pollution degree 2	

1) The cage clamp terminal block cannot be used side by side.

2) The respective limit data of the I/O modules must be taken into account!

10.6 Terminal block for IF options

10.6.1 0TB1210.3100

10.6.1.1 General information

Two-row 10-pin terminal block 0TB1210.3100 is used to connect to the interfaces of various interface options.

10.6.1.2 Order data

Order number	Short description	Figure
	Terminal blocks	
0TB1210.3100	Connector 300 VDC - 10-pin female - Cage clamp terminal block - Protected against vibration by the screw flange	

10.6.1.3 Technical data

Information:

The following specified characteristic data, features and limit values are only valid for this accessory and may differ from those of the complete system. The data specified for the complete system applies to the complete system in which an accessory is used.

Order number	0TB1210.3100
General information	
Certifications	
CE	Yes
UKCA	Yes
UL	cULus E115267 Industrial control equipment
HazLoc	cULus HazLoc E180196 Industrial control equipment for hazardous locations Class I, Division 2, Groups ABCD, T4
DNV	Temperature: B (0 to 55°C) Humidity: B (up to 100%) Vibration: A (0.7 g) EMC: B (bridge and open deck)
LR	ENV3
KR	Yes
ABS	Yes
BV	EC31B Temperature: 5 - 55°C Vibration: 0.7 g EMC: Bridge and open deck
Terminal block	
Note	Nominal data per UL
Number of pins	10 (female)
Type of terminal block	Push-in spring connection
Cable type	Only copper wires (no aluminum wires!)
Pitch	3.5 mm
Connection cross section	
AWG wire	26 to 16 AWG
Wire end sleeves with plastic covering	0.14 to 1 mm ²
Single-wire	0.14 to 1.5 mm ²
Fine-stranded wires	0.14 to 1.5 mm ²
With wire end sleeves	0.14 to 1.5 mm ²
Electrical properties	
Nominal voltage	300 V
Nominal current ¹⁾	10 A
Operating conditions	
Pollution degree per EN 61131-2	Pollution degree 2

1) The respective limit data of the I/O modules must be taken into account!

10.7 USB hub

10.7.1 5ACCUSB4.0000-000

10.7.1.1 General information

- USB hub 5ACCUSB4.0000-000 can be installed starting with the following revisions of the system units:

System unit	Minimum revision	System unit	Minimum revision
5APC2100.BY01-000	E0	5APC2100.BY11-000	E0
5APC2100.BY22-000	E0	5APC2100.BY34-000	E0
5APC2100.BY44-000	E0	5APC2100.BY48-000	A0

- Front cover 5ACCCFF00.0001-00x is required to enable correct installation and operation.

Features

- 4x USB 2.0, interfaces
- Compatible with the APC2100 and PPC2100

Installation

For details about installing the USB hub, see section "Installing the USB hub" on page 93.

10.7.1.2 Order data

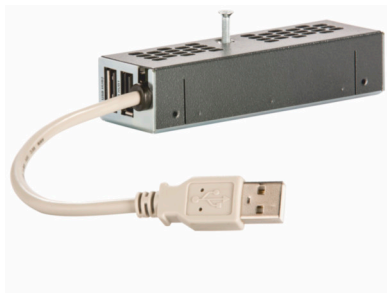
Order number	Short description	Figure
	Accessories	
5ACCUSB4.0000-000	USB hub 4x passive - For APC2100/PPC2100	
	Required accessories	
	Front covers	
5ACCCFF00.0001-000	APC2100 front cover - Orange - With B&R logo - For USB hub	
5ACCCFF00.0001-001	APC2100 front cover - Dark gray - Without logo - For USB hub	
5ACCCFF00.0001-002	APC2100 front cover - Orange - Without logo - For USB hub	

10.7.1.3 Technical data

Information:

The following specified characteristic data, features and limit values are only valid for this accessory and may differ from those of the complete system. The data specified for the complete system applies to the complete system in which an accessory is used.

Order number	5ACCUSB4.0000-000
General information	
B&R ID code	0xEABA
Certifications	
CE	Yes
UKCA	Yes
UL	cULus E115267 Industrial control equipment
HazLoc	cULus HazLoc E180196 Industrial control equipment for hazardous locations
EAC	Class I, Division 2, Groups ABCD, T4 Product family certification
Interfaces	
USB	
Quantity	4
Type	USB 2.0
Variant	Type A
Transfer rate	Low speed (1.5 Mbit/s), full speed (12 Mbit/s) to high speed (480 Mbit/s)
Current-carrying capacity	Total max. 1 A (sum of all 4 ports)
Operating conditions	
Pollution degree per EN 61131-2	Pollution degree 2
Degree of protection per EN 60529	Back: IP20 (front: depends on the panel used) ¹⁾

Order number	5ACCUSB4.0000-000
Ambient conditions	
Temperature	
Operation	0 to 60°C ²⁾
Storage	-20 to 60°C
Transport	-20 to 60°C
Relative humidity	
Operation	5 to 90%, non-condensing
Storage	5 to 95%, non-condensing
Transport	5 to 95%, non-condensing
Elevation	
Operation	Max. 3000 m ²⁾
Mechanical properties	
Housing	
Material	Stainless steel, coated
Coating	Anthracite gray
Dimensions	
Width	21.5 mm
Height	29.5 mm
Depth	97 mm
Weight	100 g

1) Only if all interface covers are installed.

2) The maximum ambient temperature is typically derated 1°C per 1000 meters starting at 500 m above sea level.

10.7.1.3.1 USB interfaces

The 4-port USB hub is equipped with a USB 2.0 (Universal Serial Bus) host controller with several USB ports, of which four USB 2.0 interfaces are routed externally and freely available to the user.

Warning!

USB peripheral devices can be connected to the USB interfaces. Due to the variety of USB devices available on the market, B&R cannot guarantee their functionality. The functionality of USB devices available from B&R is ensured.

Caution!

Due to the general PC specification, this interface must be handled with the utmost care with regard to EMC, cable routing, etc.

USB HUB 1 - USB HUB 4

USB HUB 1 - USB HUB 4	
Standard	USB 2.0
Variant	Type A, female
Quantity	4
Transfer rate	Low speed (1.5 Mbit/s)
	Full speed (12 Mbit/s)
	High speed (480 Mbit/s)
Current-carrying capacity ¹⁾	Total max. 1 A (sum of all 4 ports)
Cable length	
USB2.0	Max. 5 m

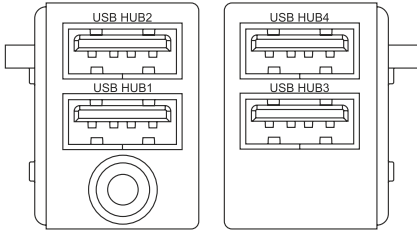

1) The USB hub is protected by a maintenance-free "USB current-limiting switch" (max. 1 A).

Information:

If a Technology Guard (USB dongle) is used, it is recommended to connect it to the USB HUB 3 interface.

10.7.1.4 Dimensions

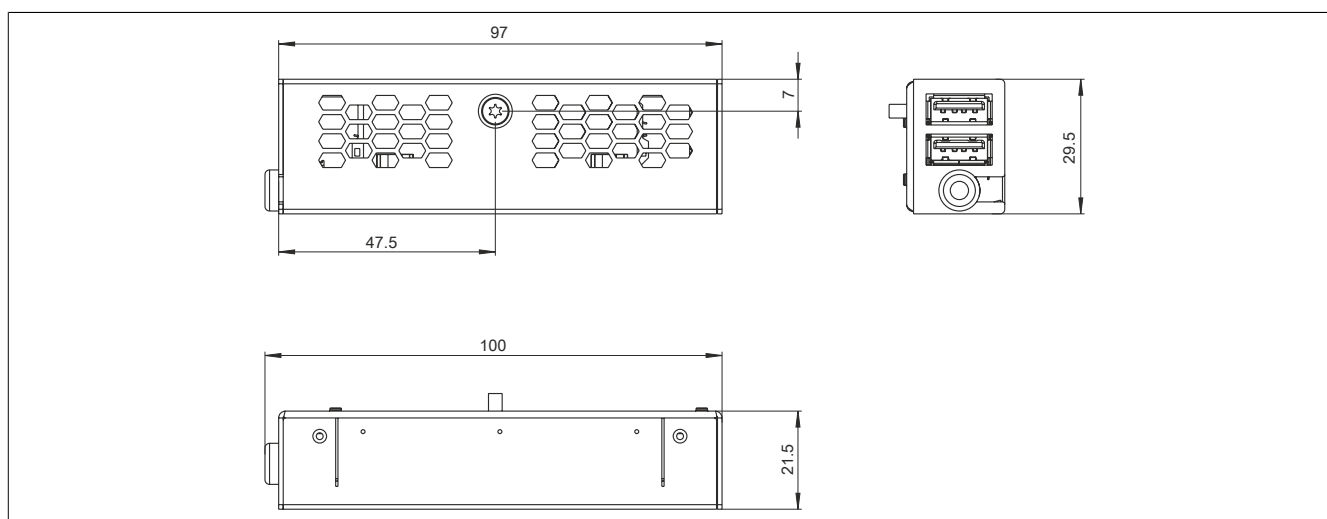

11 Environmentally friendly disposal

All programmable logic controllers, operating and monitoring devices and uninterruptible power supplies from B&R are designed to have as little impact on the environment as possible.

11.1 Separation of materials

To ensure that devices can be recycled in an environmentally friendly manner, it is necessary to separate out the different materials.

Component	Disposal
Programmable logic controllers Operating and monitoring devices Uninterruptible power supplies Batteries and rechargeable batteries Cables	Electronics recycling
Paper/Cardboard packaging	Paper/Cardboard recycling
Plastic packaging material	Plastic recycling

Disposal must be carried out in accordance with applicable legal regulations.

Appendix A

A.A Abbreviations

Abbreviations used in the document are explained here.

Abbreviation	Stands for	Description
NC	Normally closed	Stands for a normally closed relay contact.
	Not connected	Used in pinout descriptions if a terminal or pin is not connected on the module side.
ND	Not defined	Stands for an undefined value in technical data tables. This may be because the cable manufacturer has not provided a value for certain technical data.
NO	Normally open	Stands for a normally open relay contact.
TBD	To be defined	Used in technical data tables if there is currently no value for specific technical data. The value will be supplied later.
B ₁₀₀	-	Number of cycles until 10% of the components fail dangerously (per channel).
MTBF	Mean time between failures	The expected value of the operating time between two consecutive failures.
MTTF _D	Mean time to dangerous failure	Mean time to dangerous failure (per channel).
DC	Diagnostic coverage	Degree of diagnostic coverage
PL	Performance level	Discrete level specifying the ability of safety-related devices to perform a safety function under foreseeable conditions.
PFH	Probability of failure per hour	Probability of a failure per hour.
SIL	Safety integrity level	Safety integrity level

A.B Maintenance Controller Extended (MTCX)

The MTCX controller (FPGA processor) is located on the mainboard (part of each system unit) of the APC2100 and PPC2100 device.

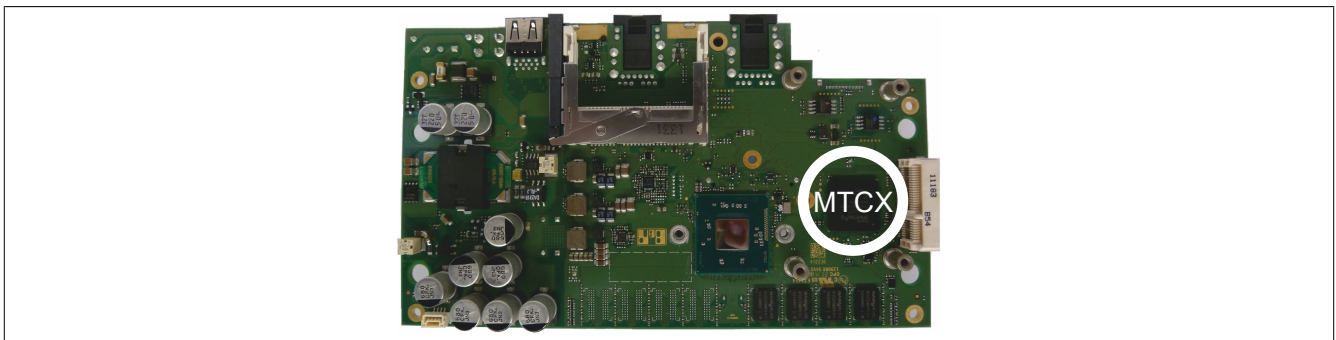

The MTCX is responsible for the following monitoring and control functions:

- Switching on (power OK sequencing) and power failure logic
- Watchdog handling (NMI and reset handling)
- Temperature monitoring
- Fan control
- Handling/Coordination of keys and LEDs (matrix keyboard of B&R panels)
- Advanced desktop operation (buttons, USB forwarding)
- Daisy chain display operation (touch screen, USB forwarding)
- Panel locking mechanism (configurable via the B&R Control Center - ADI driver)
- Backlight control of a connected B&R display
- Calculating statistical data: Power-on cycles, power-on hours and fan hours (resolution: 15 min)
- SDL data transfer (display, matrix keyboard, touch screen, service data, USB)
- LED status indicators (Power, HDD, Link, Run)
- Optimal default BIOS settings are reported to BIOS by the MTCX depending on the existing hardware.

The functions of the MTCX can be extended by upgrading its firmware⁶⁾. The version can be read in BIOS or in approved Microsoft Windows operating systems using the B&R Control Center.

⁶⁾ Can be downloaded from the Downloads section of the B&R website (www.br-automation.com).

A.C Cable data

Signal		Signal	
RS232	"RS232 - Bus length and cable type" on page 180	RS422	"RS422 - Bus length and cable type" on page 180
RS485	"RS485 - Bus length and cable type" on page 181	CAN	"CAN - Bus length and cable type" on page 181

A.C.1 RS232 - Bus length and cable type

The maximum transfer rate of 115 kbit/s depends on the cable length and type of cable used.

Bus length	Transfer rate
≤15 m	Typ. 64 kbit/s
≤10 m	Typ. 115 kbit/s
≤5 m	Typ. 115 kbit/s

Preferably, the cable material used should have the following properties or deviate only slightly from them in order to achieve an optimal transfer rate.

RS232 cables	Property
Signal line	
Cable cross section	4x 0.16 mm ² (26 AWG), tinned copper stranded wire
Wire insulation	PE
Conductor resistance	≤82 Ω/km
Stranding	Twisted-pair wires
Shield	Pair shielding with aluminum foil
GND	
Cable cross section	1x 0.34 mm ² (22AWG/19), tinned copper stranded wire
Wire insulation	PE
Conductor resistance	≤59 Ω/km
Outer jacket	
Material	PUR compound
Properties	Halogen-free
Cable shield	Tinned copper wire

A.C.2 RS422 - Bus length and cable type

The RTS line must be switched on to activate the transmitter.

The maximum transfer rate of 115 kbit/s depends on the cable length and type of cable used.

Bus length	Transfer rate
1200 m	Typ. 115 kbit/s

Preferably, the cable material used should have the following properties or deviate only slightly from them in order to achieve an optimal transfer rate.

RS422 cables	Property
Signal line	
Cable cross section	4x 0.25 mm ² (24AWG/19), tinned copper stranded wire
Wire insulation	PE
Conductor resistance	≤82 Ω/km
Stranding	Twisted-pair wires
Shield	Pair shielding with aluminum foil
GND	
Cable cross section	1x 0.34 mm ² (22AWG/19), tinned copper stranded wire
Wire insulation	PE
Conductor resistance	≤59 Ω/km
Outer jacket	
Material	PUR compound
Properties	Halogen-free
Cable shield	Tinned copper wire

A.C.3 RS485 - Bus length and cable type

The maximum transfer rate of 115 kbit/s depends on the cable length and type of cable used.

Bus length	Transfer rate
1200 m	Typ. 115 kbit/s

Preferably, the cable material used should have the following properties or deviate only slightly from them in order to achieve an optimal transfer rate.

RS485 cables	Property
Signal line	
Cable cross section	4x 0.25 mm ² (24AWG/19), tinned copper stranded wire
Wire insulation	PE
Conductor resistance	≤82 Ω/km
Stranding	Twisted-pair wires
Shield	Pair shielding with aluminum foil
GND	
Cable cross section	1x 0.34 mm ² (22AWG/19), tinned copper stranded wire
Wire insulation	PE
Conductor resistance	≤59 Ω/km
Outer jacket	
Material	PUR compound
Properties	Halogen-free
Cable shield	Tinned copper wire

A.C.4 CAN - Bus length and cable type

The type of cable to be used depends largely on the required bus length and number of nodes. The bus length is determined by the transfer rate. Per CiA (CAN in Automation), the maximum bus length is 1000 meters.

The following bus lengths are permitted at a maximum permissible oscillator tolerance of 0.121%:

Bus length ¹⁾	Transfer rate
≤1000 m	Typ. 50 kbit/s
≤200 m	Typ. 250 kbit/s
≤100 m	Typ. 500 kbit/s
≤20 m ²⁾	Typ. 1 Mbit/s
≤15 m ³⁾	

- 1) The specified cable length is only valid with the values specified in "CAN driver settings". Cable lengths otherwise depend on the values in the bit timing register, cable quality and number of nodes.
- 2) For CAN interfaces without galvanic isolation and 5ACCIF01.ICAN-000.
- 3) For CAN interfaces with galvanic isolation.

Preferably, the cable material used should have the following properties or deviate only slightly from them in order to achieve an optimal transfer rate.

CAN cable	Property
Signal line	
Cable cross section	2x 0.25 mm ² (24AWG/19), tinned copper stranded wire
Wire insulation	PE
Conductor resistance	≤82 Ω/km
Stranding	Twisted-pair wires
Shield	Pair shielding with aluminum foil
GND	
Cable cross section	1x 0.34 mm ² (22AWG/19), tinned copper stranded wire
Wire insulation	PE
Conductor resistance	≤59 Ω/km
Outer jacket	
Material	PUR compound
Properties	Halogen-free
Cable shield	Tinned copper wire

A.D POWERLINK

A.D.1 LED "S/E" (status/error LED)

This LED is a green/red dual LED and indicates the state of the POWERLINK interface. The LED states have a different meaning depending on the operating mode of the POWERLINK interface.

A.D.1.1 Ethernet mode

In this mode, the interface is operated as an Ethernet interface.

LED "S/E"		Description
Green	Red	
On	Off	The interface is operated as an Ethernet interface.

Table: LED "S/E": Interface in Ethernet mode

A.D.1.2 POWERLINK V2 mode

Error message

LED "S/E"		Description
Green	Red	
Off	On	The interface is in error mode (failed Ethernet frames, increased number of collisions on the network, etc.). Note: Several red blinking signals are displayed immediately after the device is switched on. These are not errors, however.
Blinking	On	If an error occurs in the following modes, then the green LED blinks over the red LED: <ul style="list-style-type: none"> PRE_OPERATIONAL_1 PRE_OPERATIONAL_2 READY_TO_OPERATE 

Table: LED "S/E" - Error message (interface in POWERLINK mode)

Interface status

LED "S/E"		Description
Green	Red	
Off	Off	Mode: NOT_ACTIVE The interface is either in mode NOT_ACTIVE or one of the following modes or errors is present: <ul style="list-style-type: none"> The device is switched off. The device is in the startup phase. The interface or device is not configured correctly in Automation Studio. The interface or device is defective. Managing node (MN) The network is monitored for POWERLINK frames. If a frame is not received within the configured time window (timeout), the interface immediately enters mode PRE_OPERATIONAL_1. If POWERLINK communication is detected before the time has elapsed, however, the MN is not started.
Flickering (approx. 10 Hz)	Off	Mode: BASIC_ETHERNET The interface is in mode BASIC_ETHERNET. The interface is operated in Ethernet mode . Managing node (MN) This mode can only be exited by resetting the controller. Controlled node (CN) If POWERLINK communication is detected during this mode, the interface enters mode PRE_OPERATIONAL_1.

Table: LED "S/E" - Interface state (interface in POWERLINK mode)

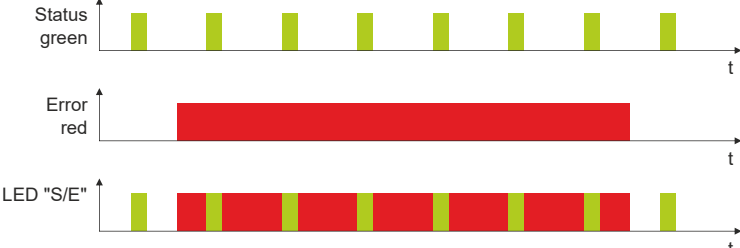
LED "S/E"		Description
Green	Red	
Single flash (approx. 1 Hz)	Off	Mode: PRE_OPERATIONAL_1 The interface is in mode PRE_OPERATIONAL_1. Managing node (MN) The MN is in "reduced cycle" mode. The CNs are configured in this mode. Cyclic communication is not yet taking place. Controlled node (CN) The CN can be configured by the MN in this mode. The CN waits until it receives an SoC frame and then switches to mode PRE_OPERATIONAL_2.
	On	Controlled node (CN) If the red LED lights up in this mode, this means that the MN has failed.
Double flash (approx. 1 Hz)	Off	Mode: PRE_OPERATIONAL_2 The interface is in mode PRE_OPERATIONAL_2. Managing node (MN) The MN starts cyclic communication (cyclic input data is not yet evaluated). The CNs are configured in this mode. Controlled node (CN) The CN can be configured by the MN in this mode. A command then switches the mode to READY_TO_OPERATE.
	On	Controlled node (CN) If the red LED lights up in this mode, this means that the MN has failed.
Triple flash (approx. 1 Hz)	Off	Mode: READY_TO_OPERATE The interface is in mode READY_TO_OPERATE. Managing node (MN) Cyclic and asynchronous communication. Received PDO data is ignored. Controlled node (CN) The configuration of the CN is completed. Normal cyclic and asynchronous communication. The transmitted PDO data corresponds to the PDO mapping. However, cyclic data is not yet evaluated.
	On	Controlled node (CN) If the red LED lights up in this mode, this means that the MN has failed.
On	Off	Mode: OPERATIONAL The interface is in mode OPERATIONAL. PDO mapping is active and cyclic data is evaluated.
Blinking (approx. 2.5 Hz)	Off	Mode: STOPPED The interface is in mode STOPPED. Managing node (MN) This mode does not occur for the MN. Controlled node (CN) Output data is not being output, and no input data is being provided. This mode can only be reached and exited by a corresponding command from the MN.

Table: LED "S/E" - Interface state (interface in POWERLINK mode)

Blink times

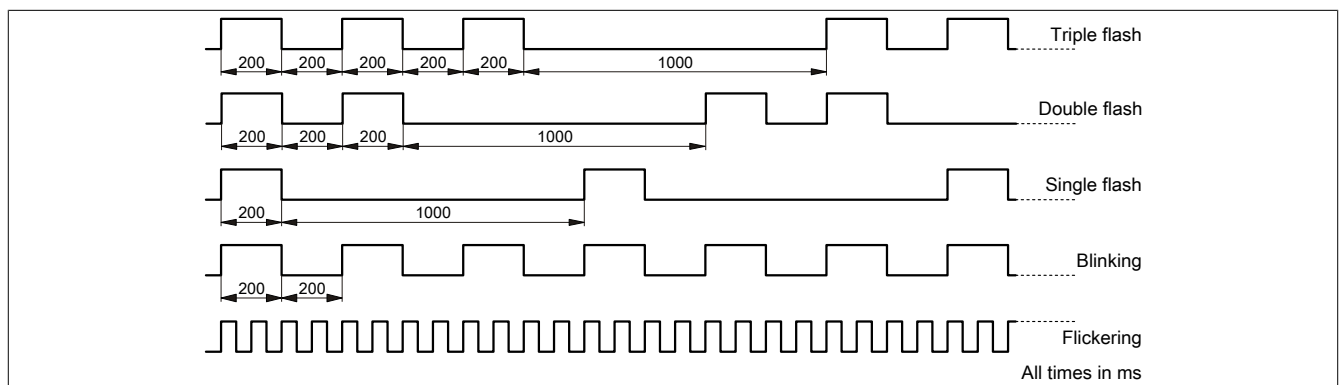

A.D.1.3 System stop error codes

A system stop error can occur due to incorrect configuration or defective hardware.

The error code is indicated by LED "S/E" blinking red. The blinking signal of the error code consists of 4 switch-on phases with short (150 ms) or long (600 ms) duration. The error code is repeated every 2 seconds.

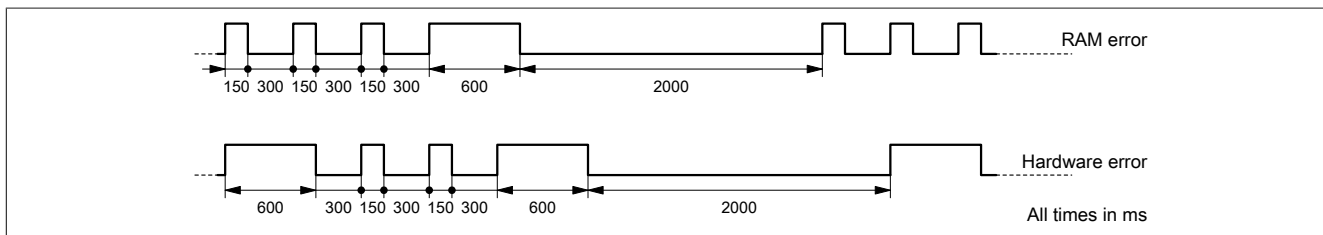

Error	Error description
RAM error	The device is defective and must be replaced.
Hardware error	The device or a system component is defective and must be replaced.

A.D.1.4 POWERLINK V2

By default, the POWERLINK interface is operated as a managing node (MN). In the managing node, the node number is set to a fixed value of 240.

If the POWERLINK node is operated as a controlled node (CN), a node number from 1 to 239 can be set in the POWERLINK configuration in Automation Studio.