

X20(c)PS2100

1 General information

The supply module is used for the internal I/O supply.

- 24 VDC supply module for internal I/O supply

2 Coated modules

Coated modules are X20 modules with a protective coating for the electronics component. This coating protects X20c modules from condensation and corrosive gases.

The modules' electronics are fully compatible with the corresponding X20 modules.

For simplification purposes, only images and module IDs of uncoated modules are used in this data sheet.

The coating has been certified according to the following standards:

- Condensation: BMW GS 95011-4, 2x 1 cycle
- Corrosive gas: EN 60068-2-60, method 4, exposure 21 days



3 Order data

Order number	Short description	Figure
	Power supplies	
X20PS2100	X20 power supply module, for internal I/O power supply	
X20cPS2100	X20 power supply module, coated, for internal I/O power supply	
	Required accessories	
	Bus modules	
X20BM01	X20 power supply bus module, 24 VDC keyed, internal I/O power supply interrupted to the left	
X20BM05	X20 power supply bus module, with node number switch, 24 VDC keyed, internal I/O power supply interrupted to the left	
X20cBM01	X20 power supply bus module, coated, 24 VDC keyed, internal I/O power supply interrupted to the left	
	Terminal blocks	
X20TB12	X20 terminal block, 12-pin, 24 VDC keyed	

Table 1: X20PS2100, X20cPS2100 - Order data

4 Technical data

Order number	X20PS2100	X20cPS2100
Short description		
Power supply module	24 VDC power supply module for internal I/O power supply	
General information		
B&R ID code	0x1BBF	0xE23C
Status indicators	Operating state, module status	
Diagnostics		
Module run/error	Yes, using LED status indicator and software	
Power consumption ¹⁾		
Bus	0.2 W	
Internal I/O	0.6 W	
Additional power dissipation caused by actuators (resistive) [W]	-	
Certifications		
CE	Yes	
UKCA	Yes	
ATEX	Zone 2, II 3G Ex nA nC IIA T5 Gc IP20, Ta (see X20 user's manual) FTZÚ 09 ATEX 0083X	
UL	cULus E115267 Industrial control equipment	
HazLoc	cCSAus 244665 Process control equipment for hazardous locations Class I, Division 2, Groups ABCD, T5	
DNV	Temperature: B (0 - 55°C) Humidity: B (up to 100%) Vibration: B (4 g) EMC: B (bridge and open deck)	
LR	ENV1	
KR	Yes	
ABS	Yes	
EAC	Yes	
KC	Yes	-
Input I/O power supply		
Input voltage	24 VDC -15% / +20%	
Fuse	Required line fuse: Max. 10 A, slow-blow	
Reverse polarity protection	No	
Output I/O power supply		
Nominal output voltage	24 VDC	
Behavior on short circuit	Required line fuse	
Permissible contact load	10 A	
Electrical properties		
Electrical isolation	I/O supply not isolated from I/O power supply	
Operating conditions		
Mounting orientation		
Horizontal	Yes	
Vertical	Yes	
Installation elevation above sea level		
0 to 2000 m	No limitation	
>2000 m	Reduction of ambient temperature by 0.5°C per 100 m	
Degree of protection per EN 60529	IP20	
Ambient conditions		
Temperature		
Operation		
Horizontal mounting orientation	-25 to 60°C	
Vertical mounting orientation	-25 to 50°C	
Derating		
Storage	-40 to 85°C	
Transport	-40 to 85°C	
Relative humidity		
Operation	5 to 95%, non-condensing	Up to 100%, condensing
Storage	5 to 95%, non-condensing	
Transport	5 to 95%, non-condensing	
Mechanical properties		
Note	Order 1x terminal block X20TB12 separately. Order 1x power supply bus module X20BM01 separately	Order 1x terminal block X20TB12 separately. Order 1x power supply bus module X20cBM01 separately
Pitch	12.5 ^{+0.2} mm	

Table 2: X20PS2100, X20cPS2100 - Technical data

1) The specified values are maximum values. For examples of the exact calculation, see section "Mechanical and electrical configuration" in the X20 system user's manual.

5 LED status indicators

For a description of the various operating modes, see section "Additional information - Diagnostic LEDs" in the X20 system user's manual.

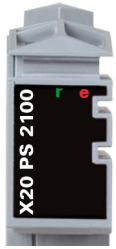
Figure	LED	Color	Status	Description
	r	Green	Off	No power to module
			Single flash	RESET mode
			Blinking	PREOPERATIONAL mode
			On	RUN mode
	e	Red	Off	No power to module or everything OK
			Double flash	LED indicates one of the following states: <ul style="list-style-type: none"> I/O supply too low X2X link voltage too low
	e + r		Red on / Green single flash	Invalid firmware

6 Pinout

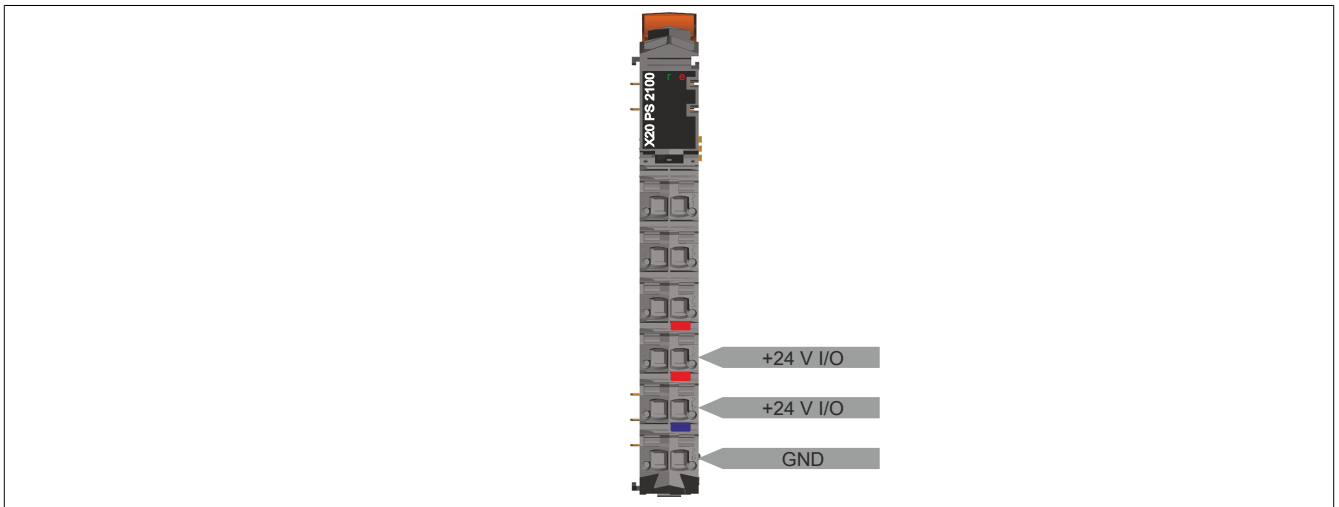

7 Connection example

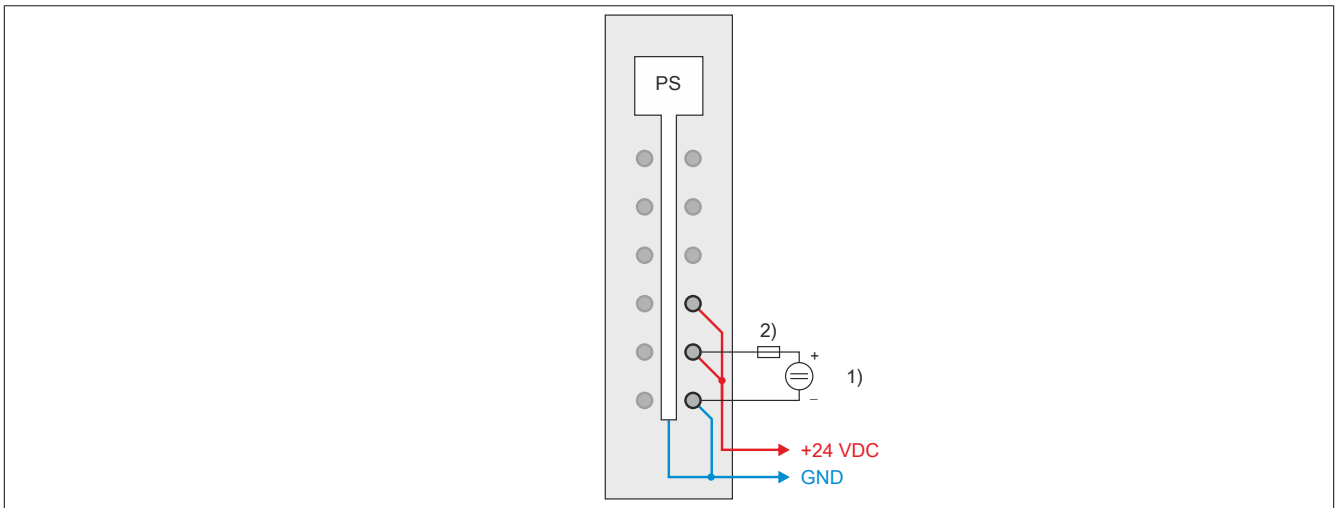

- 1) Supply for the I/O power supply
- 2) Fuse, 10 A slow-blow

8 Safe shutdown of potential group

In safety-related applications, it must be guaranteed that the potential group is safely shut down in order to achieve a category 4 shutdown in accordance with EN ISO 13849-1. An X20PS2100 (rev.F0 or higher) or X20PS2110 (rev.C0 or higher) supply module must be used to do this.

For important notes concerning "safe shutdown", see section "Mechanical and electrical configuration" of the X20 system user's manual. The user's manual can be downloaded from the Downloads section of the B&R website (www.br-automation.com).

9 Register description

9.1 General data points

In addition to the registers described in the register description, the module has additional general data points. These are not module-specific but contain general information such as serial number and hardware variant.

General data points are described in section "Additional information - General data points" in the X20 system user's manual.

9.2 Function model 0 - Standard

Register	Fixed offset	Name	Data type	Read		Write	
				Cyclic	Acyclic	Cyclic	Acyclic
0	1	Status of the module	USINT	•			
		StatusInput01	Bit 0				
		StatusInput02	Bit 2				
4	3	SupplyVoltage	USINT	•			

Fixed modules require their data points to be in a specific order in the X2X frame. Cyclic access occurs according to a predefined offset, not based on the register address.

Acyclic access continues to be based on the register numbers.

9.3 Function model 254 - Bus controller

Register	Offset ¹⁾	Name	Data type	Read		Write	
				Cyclic	Acyclic	Cyclic	Acyclic
0	0	Status of the module	UINT	•			
		StatusInput01	Bit 0				
		StatusInput02	Bit 2				
4	4	SupplyVoltage	UINT	•			

1) The offset specifies the position of the register within the CAN object.

9.3.1 Using the module on the bus controller

Function model 254 "Bus controller" is used by default only by non-configurable bus controllers. All other bus controllers can use other registers and functions depending on the fieldbus used.

For detailed information, see section "Additional information - Using I/O modules on the bus controller" in the X20 user's manual (version 3.50 or later).

9.3.2 CAN I/O bus controller

The module occupies 1 analog logical slot on CAN I/O.

9.4 Status of the module

Name:

Module status

The following module power supply voltages are monitored in this register:

Bus supply voltage:	Bus supply voltage <4.7 V is displayed as a warning.
24 VDC I/O supply voltage:	I/O supply voltage <20.4 V is displayed as a warning.

Function model	Data type	Values
0 - Standard	USINT	See the bit structure.
254 - Bus controller	UINT	See the bit structure.

Bit structure:

Bit	Name	Value	Information
0	StatusInput01	0	No error
		1	Bus power supply warning - Undervoltage (<4.7 V)
1	Reserved	0	
2	StatusInput02	0	I/O power supply above the warning limit of 20.4 V
		1	I/O power supply below the warning limit of 20.4 V
3 - x	Reserved	0	

9.5 Bus supply voltage

Name:

SupplyVoltage

This register indicates the bus supply voltage measured at a resolution of 0.1 V.

Information:

The nominal bus supply voltage is 5 V and should not fall below 4.7 V.

Function model	Data type
0 - Standard	USINT
254 - Bus controller	UINT

9.6 Minimum cycle time

The minimum cycle time specifies how far the bus cycle can be reduced without communication errors occurring. It is important to note that very fast cycles reduce the idle time available for handling monitoring, diagnostics and acyclic commands.

Minimum cycle time
100 μ s

9.7 Minimum I/O update time

The minimum I/O update time specifies how far the bus cycle can be reduced so that an I/O update is performed in each cycle.

Minimum I/O update time
2 ms