

# X20AO4632-1

## 1 General information

The module is equipped with 4 outputs with 16-bit (including sign) digital converter resolution. It is possible to select between the current and voltage signal using different terminals.

- 4 analog outputs
- Either current or voltage signal possible
- Extended signal range
- 16-bit digital converter resolution
- NetTime timestamp: Switch-off time

### NetTime timestamp for output

For many applications, not only the output value is important, but also the exact switching time. The module is equipped with a NetTime timestamp function for this that can define a switching time to the nearest microsecond.

The timestamp function is based on synchronized timers. The controller can predefine output events and provide them with a timestamp. After transferring the respective data, including the exact time, the module executes the predefined action at the exactly defined time.

### 1.1 Other applicable documents

For additional and supplementary information, see the following documents.

#### Other applicable documents

Document name	Title
MAX20	<a href="#">X20 system user's manual</a>
MAEMV	<a href="#">Installation / EMC guide</a>

## 2 Order data

Order number	Short description	Figure
	<b>Analog outputs</b>	
X20AO4632-1	X20 analog output module, 4 outputs, $\pm 11$ V or 0 to 22 mA, 16-bit converter resolution, NetTime function	
	<b>Required accessories</b>	
	<b>Bus modules</b>	
X20BM11	X20 bus module, 24 VDC keyed, internal I/O power supply connected through	
X20BM15	X20 bus module, with node number switch, 24 VDC keyed, internal I/O power supply connected through	
	<b>Terminal blocks</b>	
X20TB12	X20 terminal block, 12-pin, 24 VDC keyed	

Table 1: X20AO4632-1 - Order data

## 3 Technical description

### 3.1 Technical data

Order number	X20AO4632-1
<b>Short description</b>	
I/O module	4 analog outputs $\pm 11$ V or 0 to 22 mA
<b>General information</b>	
B&R ID code	0xC36F
Status indicators	I/O function per channel, operating state, module status
Diagnostics	
Module run/error	Yes, using LED status indicator and software
Channel type	Yes, using software
Power consumption	
Bus	0.01 W
Internal I/O	2.15 W
Additional power dissipation caused by actuators (resistive) [W]	-
Certifications	
CE	Yes
UKCA	Yes
ATEX	Zone 2, II 3G Ex nA nC IIA T5 Gc IP20, Ta (see X20 user's manual) FTZÜ 09 ATEX 0083X
UL	cULus E115267 Industrial control equipment
HazLoc	cCSAus 244665 Process control equipment for hazardous locations Class I, Division 2, Groups ABCD, T5
DNV	Temperature: <b>B</b> (0 - 55°C) Humidity: <b>B</b> (up to 100%) Vibration: <b>B</b> (4 g) EMC: <b>B</b> (bridge and open deck)
LR	ENV1
KR	Yes
ABS	Yes
EAC	Yes
KC	Yes
<b>Analog outputs</b>	
Output	$\pm 11$ V or 0 to 22 mA, via different terminal connections
Digital converter resolution	
Voltage	$\pm 15$ -bit
Current	15-bit
Conversion time	50 $\mu$ s for all outputs
Settling time on output change over entire range	500 $\mu$ s
Switch on/off behavior	Internal enable relay for startup
Max. error	
Voltage	
Gain	0.05% <sup>1)</sup>
Offset	0.015% <sup>2)</sup>
Current	
Gain	0.08% <sup>1)</sup>
Offset	0.05% <sup>2)</sup>
Output protection	Short-circuit proof
Output format	
Voltage	INT 0x8000 - 0x7FFF / 1 LSB = 0x0001 = 335.693 $\mu$ V
Current	INT 0x0000 - 0x7FFF / 1 LSB = 0x0001 = 671.386 nA
Load per channel	
Voltage	Max. $\pm 11$ mA, load $\geq 1$ k $\Omega$
Current	Max. load is 600 $\Omega$
Short-circuit proof	Current limiting $\pm 40$ mA
Output filter	First-order low-pass filter / cutoff frequency 10 kHz
Max. gain drift	
Voltage	0.008 %/°C <sup>1)</sup>
Current	0.011 %/°C <sup>1)</sup>
Max. offset drift	
Voltage	0.003 %/°C <sup>2)</sup>
Current	0.008 %/°C <sup>2)</sup>
Error caused by load change	
Voltage	Max. 0.1%, from 10 M $\Omega$ $\rightarrow$ 1 k $\Omega$ , resistive
Current	Max. 0.5%, from 1 $\Omega$ $\rightarrow$ 600 $\Omega$ , resistive
Nonlinearity	<0.007% <sup>2)</sup>
Insulation voltage between channel and bus	500 V <sub>eff</sub>

Table 2: X20AO4632-1 - Technical data

Order number	X20AO4632-1
<b>Electrical properties</b>	
Electrical isolation	Channel isolated from bus Channel not isolated from channel
<b>Operating conditions</b>	
Mounting orientation	
Horizontal	Yes
Vertical	Yes
Installation elevation above sea level	
0 to 2000 m	No limitation
>2000 m	Reduction of ambient temperature by 0.5°C per 100 m
Degree of protection per EN 60529	IP20
<b>Ambient conditions</b>	
Temperature	
Operation	
Horizontal mounting orientation	-25 to 60°C
Vertical mounting orientation	-25 to 50°C
Derating	See section "Derating".
Storage	-40 to 85°C
Transport	-40 to 85°C
Relative humidity	
Operation	5 to 95%, non-condensing
Storage	5 to 95%, non-condensing
Transport	5 to 95%, non-condensing
<b>Mechanical properties</b>	
Note	Order 1x terminal block X20TB12 separately. Order 1x bus module X20BM11 separately.
Pitch	12.5 <sup>+0.2</sup> mm

Table 2: X20AO4632-1 - Technical data

- 1) Based on the current output value.
- 2) Based on the entire output range.

### 3.2 LED status indicators

For a description of the various operating modes, see section "Additional information - Diagnostic LEDs" in the X20 system user's manual.

Figure	LED	Color	Status	Description	
	r	Green	Off	No power to module	
			Single flash	RESET mode	
			Double flash	BOOT mode (during firmware update) <sup>1)</sup>	
			Blinking	PREOPERATIONAL mode	
	e	Red	On	RUN mode	
			Off	No power to module or everything OK	
	1 - 4	Orange	On	Error or reset status	
			Off	Value = 0	
				On	Value ≠ 0

- 1) Depending on the configuration, a firmware update can take up to several minutes.

### 3.3 Pinout

The individual channels can be configured for either current or voltage signals. The type of signal is also determined by the terminals used.

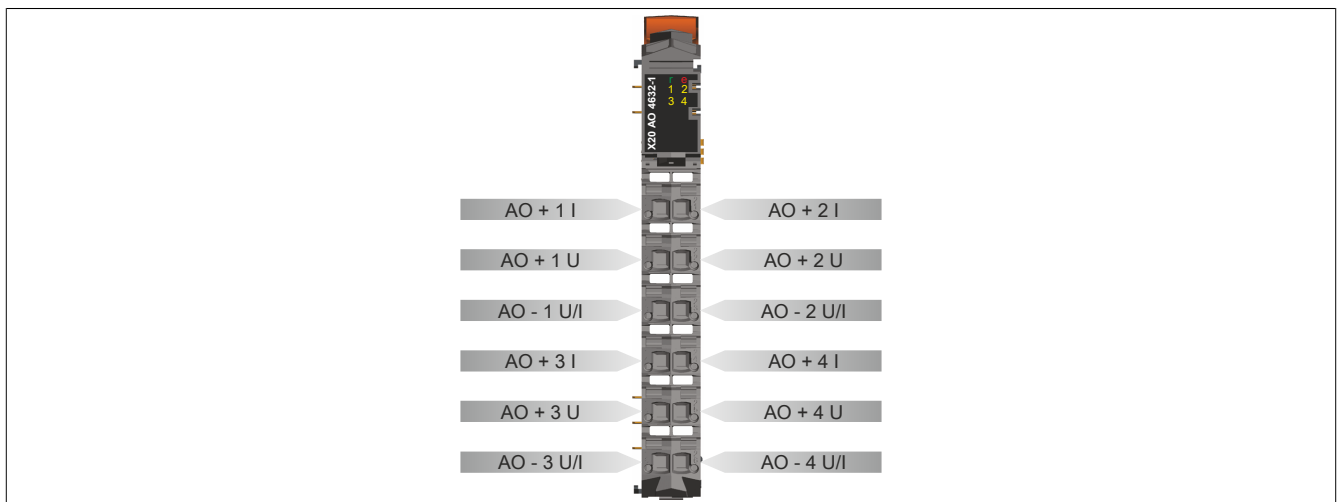

### 3.4 Connection example

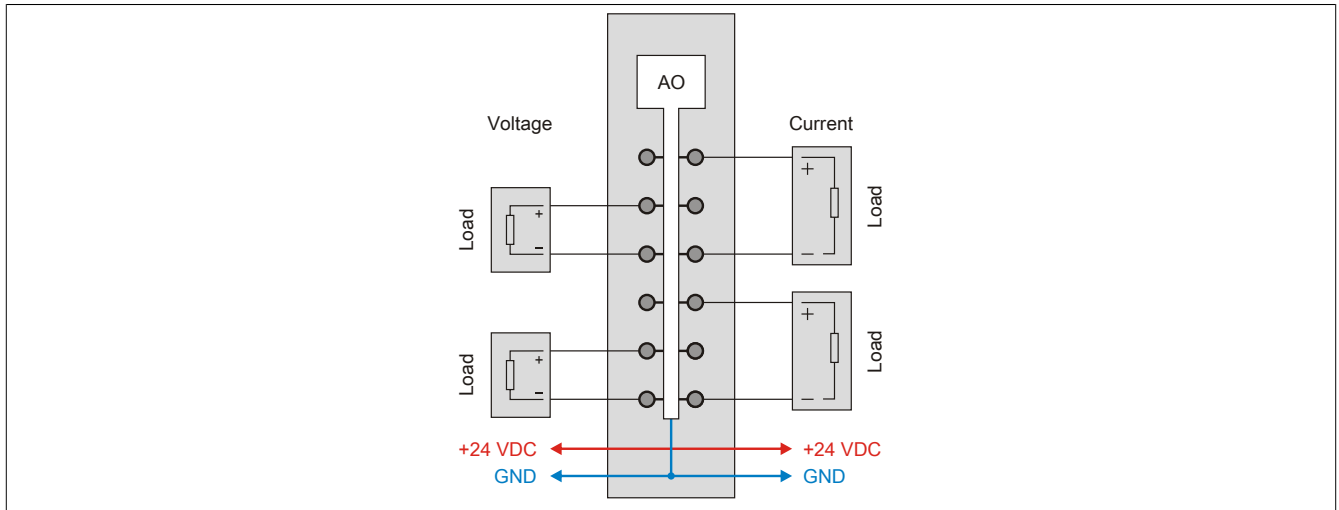

### 3.5 Output circuit diagram

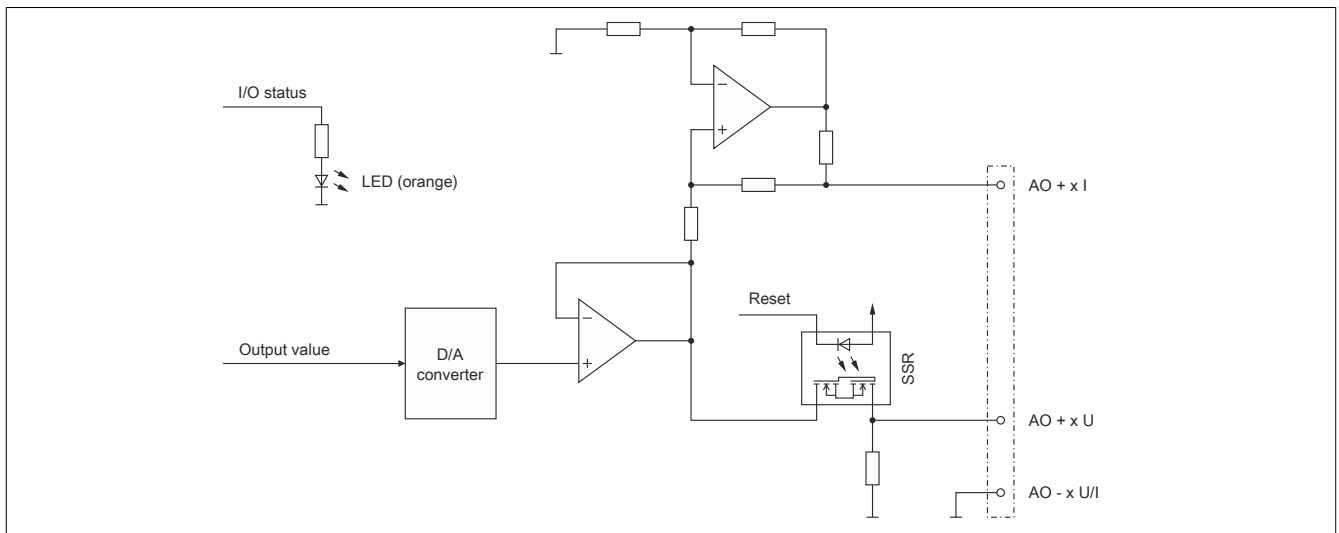

### 3.6 Derating

To ensure proper operation, the following items must be taken into consideration:

- The following derating listings must be taken into consideration
- For mixed operation with one current output, the average of both derating curves should be used
- For mixed operation with 2 or 3 current outputs, the derating for the current outputs should be used

#### Horizontal installation

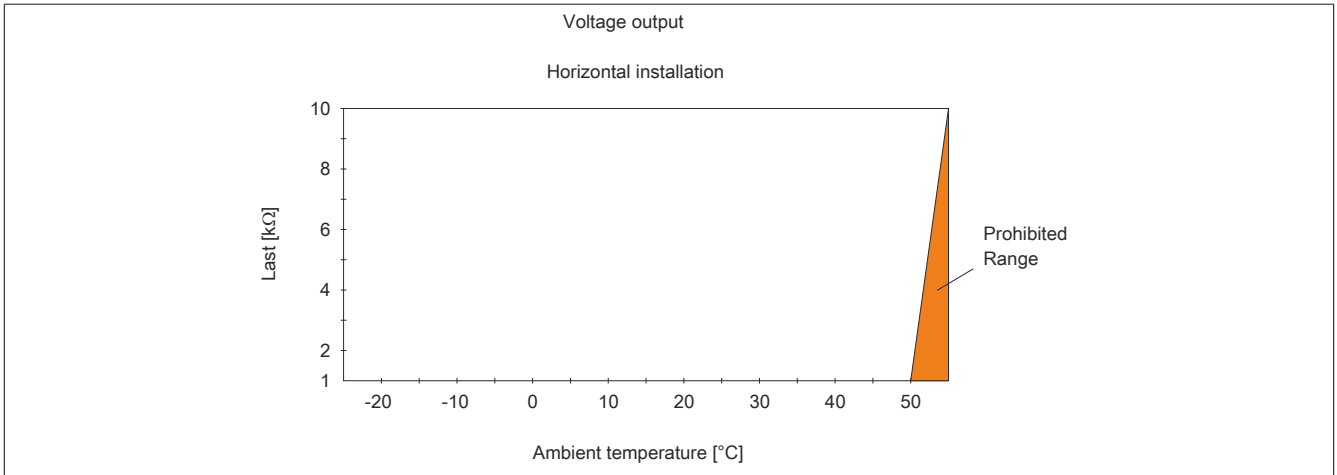

Figure 1: Derating the load with a voltage output and horizontal mounting

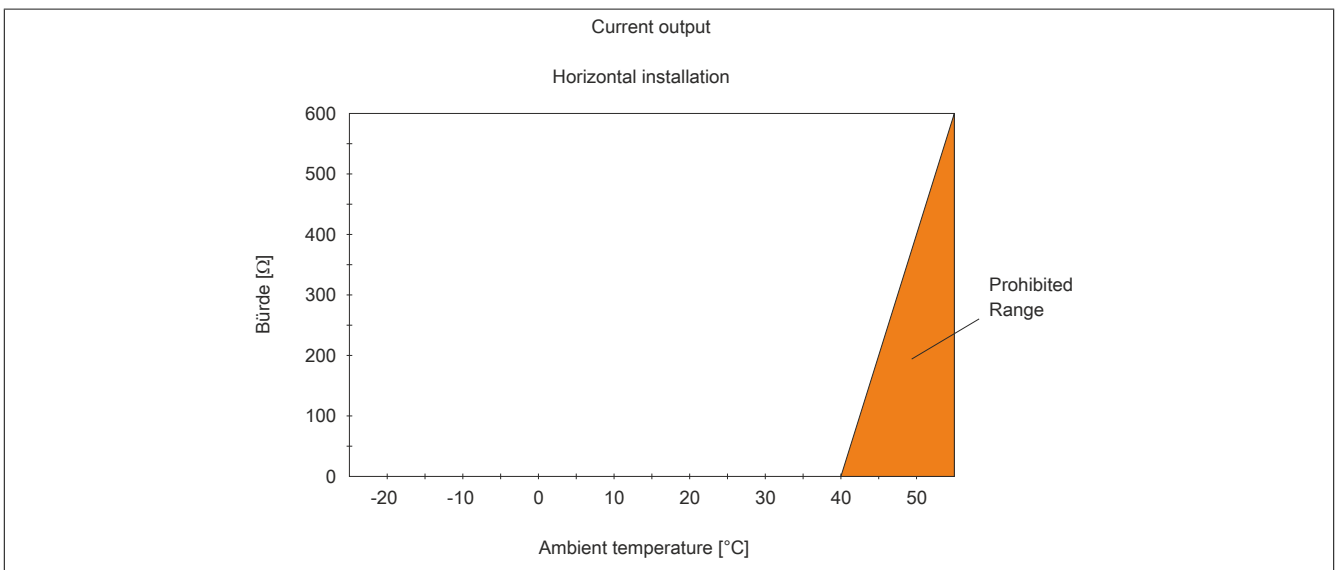

Figure 2: Derating the load with a current output and horizontal mounting

### Vertical installation

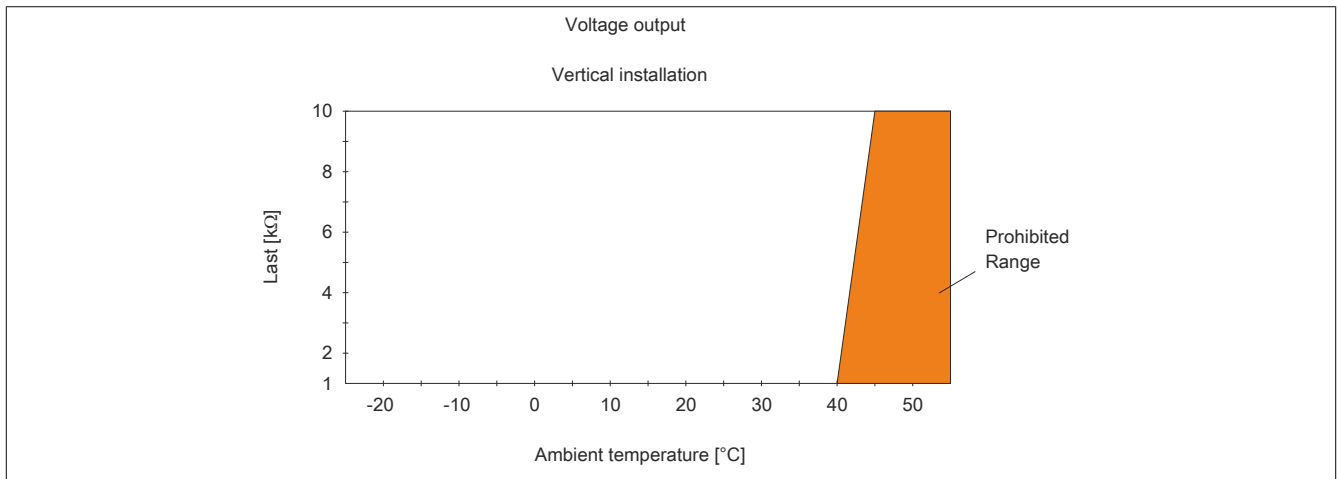

Figure 3: Derating the load with a voltage output and vertical mounting

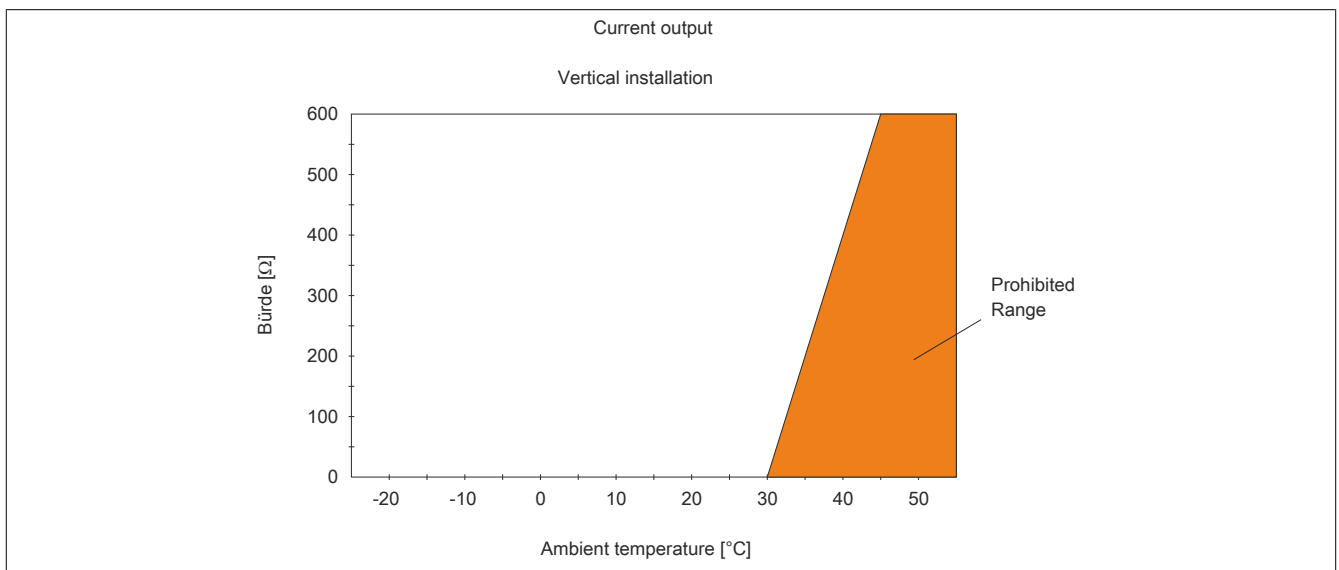

Figure 4: Derating the load with a current output and vertical mounting

## 4 Register description

### 4.1 General data points

In addition to the registers described in the register description, the module has additional general data points. These are not module-specific but contain general information such as serial number and hardware variant.

General data points are described in section "Additional information - General data points" in the X20 system user's manual.

### 4.2 Function model 0 - Standard

Register	Name	Data type	Read		Write	
			Cyclic	Non-cyclic	Cyclic	Non-cyclic
<b>Analog output - Configuration</b>						
0	ConfigOutput01 (channel type)	UINT				•
590 + Index*4	Cfo_Channel0NTimeMode (Index N = 1 to 4)	UINT				•
<b>Analog output - Communication</b>						
Index * 2	AnalogOutput0N (Index N = 1 to 4)	INT			•	
457	SDCLifeCount	SINT	•			
794 + Index*8	ValidationTimer0N (Index N = 1 to 4)	INT			•	
796 + Index*8	ValidationTimer0N (Index N = 1 to 4)	DINT			•	
833	Enabling/disabling the output channels	USINT	•		•	
	AnalogOutput01Enable, ~Readback	Bit 0				
	...	...				
	AnalogOutput04Enable, ~Readback	Bit 3				
835	Checking the output values	USINT	•			
	AnalogOutput01OK	Bit 0				
	...	...				
	AnalogOutput04OK	Bit 3				

### 4.3 Function model 254 - Bus controller

Register	Offset <sup>1)</sup>	Name	Data type	Read		Write	
				Cyclic	Non-cyclic	Cyclic	Non-cyclic
<b>Analog output - Configuration</b>							
0	-	ConfigOutput01 (channel type)	UINT				•
<b>Analog output - Communication</b>							
10 + Index * 4	Index * 2 - 2	AnalogOutput0N (Index N = 1 to 4)	INT			•	

1) The offset specifies the position of the register within the CAN object.

#### 4.3.1 Using the module on the bus controller

Function model 254 "Bus controller" is used by default only by non-configurable bus controllers. All other bus controllers can use other registers and functions depending on the fieldbus used.

For detailed information, see section "Additional information - Using I/O modules on the bus controller" in the X20 user's manual (version 3.50 or later).

#### 4.3.2 CAN I/O bus controller

The module occupies 1 analog logical slot on CAN I/O.

### 4.4 General information

The module provides 4 analog outputs. Each channel can output a voltage range of  $\pm 11$  V or a current range of 0 to 22 mA.

The module also has a time-based watchdog monitor. The user can activate this feature on a channel-by-channel basis as needed.

## 4.5 Analog output - Configuration

Each channel is configured independently. The user can also define an optional time-based monitor. To make this possible, 4 watchdog timers were implemented, which can be assigned to the outputs.

### 4.5.1 Setting the channel type

Name:

ConfigOutput01

This register can be used to set the channel type of the outputs.

Each channel is capable of handling either current or voltage signals. The type of signal is determined by the terminal connections used. Since current and voltage require different adjustment values, it is also necessary to configure the desired type of output signal. The following output signals can be set:

- $\pm 11$  V voltage signal
- 0 to 22 mA current signal

Data type	Values	Bus controller default setting
UINT	See the bit structure.	0

Bit structure:

Bit	Description	Value	Information
0 - 7	Reserved	0	
8	Channel 1	0	Voltage signal (bus controller default setting)
		1	Current signal
...		...	
11	Channel 4	0	Voltage signal (bus controller default setting)
		1	Current signal
12 - 15	Reserved	0	

### 4.5.2 Configuring the time-based watchdog monitor

Name:

Cfo\_Channel01TimeMode to Cfo\_Channel04TimeMode

This register is used to activate or configure the time-based watchdog monitor for the analog output channels.

#### Possibilities per channel:

- Validation timer data type: General choice 16 or 32 bit
- Validation window: The maximum value can be further limited within the data type.
- Timer allocation: A separate timer is available for each channel. However, all channels can be configured with the same validation timer, whereby the same settings must be made for the data type and window in the TimeMode registers.

Data type	Values
USINT	See the bit structure.

Bit structure:

Bit	Name	Value	Information
0 - 4	Max. validation time	00000	Disabled
		00001	2 $\mu$ s
		00010	4 $\mu$ s
		00011	8 $\mu$ s
		...	...
		11111	2,147,483,648 $\mu$ s (~35 min)
5 - 7	Reserved	0	
8 - 9	Timer allocation	00	ValidationTimer01 (default for channel 1)
		01	ValidationTimer02 (default for channel 2)
		10	ValidationTimer03 (default for channel 3)
		11	ValidationTimer04 (default for channel 4)
10 - 14	Reserved	0	
15	Time format	0	16-bit
		1	32-bit



## 4.6 Analog output - Communication

In standard mode, the module's outputs are enabled. Based on the configuration and AnalogOutput value, they output the corresponding current or voltage.

If the application requires time-controlled monitoring of the outputs, a validation timer can be assigned to each channel. The validation timer register assigns a validity period to the current output value. If validation is enabled, the module compares the validation time and the [NetTime](#) of the X2X Link. If the transmitted validity period is exceeded, the module switches off the channel and resets the output. State "Safety shutdown" is only exited again when a new valid validation time has been transmitted. If enabled, the module reports back which state it is currently in via the error state bit of the channel.

If the value of the validation timer is incremented in each task cycle, the valid validation time will be calculated as follows:

NetTime of the X2X Link master (to which the module is connected)	
+	Time span for transferring data from the X2X Link master to the controller (higher-level system)
+	Cycle time of task class (including tolerance)
+	Time span for transferring data from the controller to the module
+	Time span allowed by the application, e.g. to tolerate the failure of an X2X Link cycle
=	Valid validation time

The AnalogOutputEnableByte is enabled during time-based monitoring. If the timer expires prematurely, the corresponding bit in the AnalogOutputOkayByte is reset and the output drops out. This provides an easy way to achieve a defined state.

### 4.6.1 Output values of the analog outputs

Name:

AnalogOutput01 to AnalogOutput04

These registers provide the standardized output values. Once a permitted value is received, the module outputs the respective current or voltage.

#### Information:

The value "0" disables the channel status LED.

Data type	Value	
INT	-32767 to 32767	Voltage
	0 to 32767	Current

### 4.6.2 SDC counter register

Name:

SDCLifeCount

The 8-bit counter register is needed for the SDC software package. It is incremented with the system clock to allow the SDC to check the validity of the data frame.

Data type	Values
SINT	-128 to 127

### 4.6.3 Transfer of the timestamp

Name:

ValidationTimer01 to ValidationTimer04

When an output is being monitored, these registers must provide the timestamp which, when reached, will cause the output to shut down automatically. The values must be provided as signed 2-byte or 4-byte values.

For additional information about NetTime and timestamps, see "[NetTime Technology](#)" on page 11.

Data type	Values [ $\mu$ s]	
INT	-32768 to 32767	NetTime timestamp of the current output value
DINT	-2,147,483,648 to 2,147,483,647	NetTime timestamp of the current output value

#### 4.6.4 Enabling/disabling the output channels

Name:

AnalogOutput01Enable to AnalogOutput04Enable

AnalogOutput01EnableReadback to AnalogOutput04EnableReadback

Byte "OutputEnable" is only needed for the channels with enabled time control. The individual bits are used to switch the respective channels on/off. In order to obtain reliable feedback about the current module state, the byte has been additionally implemented as cyclically readable.

Data type	Value
USINT	See bit structure

Bit structure:

Bit	Name	Value	Information
0	AnalogOutput01Enable	0	Output deactivated
	AnalogOutput01EnableReadback	1	Output activated
...		...	
3	AnalogOutput04Enable	0	Output deactivated
	AnalogOutput04EnableReadback	1	Output activated
4 - 7	Reserved	0	

#### 4.6.5 Checking the output values

Name:

AnalogOutput01OK to AnalogOutput04OK

These registers are only needed for channels with activated time-based monitoring. The individual bits report whether the respective channel is actually generating the required voltage or current.

Data type	Value
USINT	See bit structure

Bit structure:

Bit	Name	Value	Information
0	AnalogOutput01OK	0	Electrical signal deactivated
		1	Electrical signal activated
...		...	
3	AnalogOutput04OK	0	Electrical signal deactivated
		1	Electrical signal activated
4 - 7	Reserved	0	

## 4.7 NetTime Technology

NetTime refers to the ability to precisely synchronize and transfer system times between individual components of the controller or network (controller, I/O modules, X2X Link, POWERLINK, etc.).

This allows the moment that events occur to be determined system-wide with microsecond precision. Upcoming events can also be executed precisely at a specified moment.



### 4.7.1 Time information

Various time information is available in the controller or on the network:

- System time (on the PLC, Automation PC, etc.)
- X2X Link time (for each X2X Link network)
- POWERLINK time (for each POWERLINK network)
- Time data points of I/O modules

The NetTime is based on 32-bit counters, which are increased with microsecond resolution. The sign of the time information changes after 35 min, 47 s, 483 ms and 648  $\mu$ s; an overflow occurs after 71 min, 34 s, 967 ms and 296  $\mu$ s.

The initialization of the times is based on the system time during the startup of the X2X Link, the I/O modules or the POWERLINK interface.

Current time information in the application can also be determined via library AsIOTime.

#### 4.7.1.1 Controller data points

The NetTime I/O data points of the controller are latched to each system clock and made available.

#### 4.7.1.2 X2X Link - Reference time point

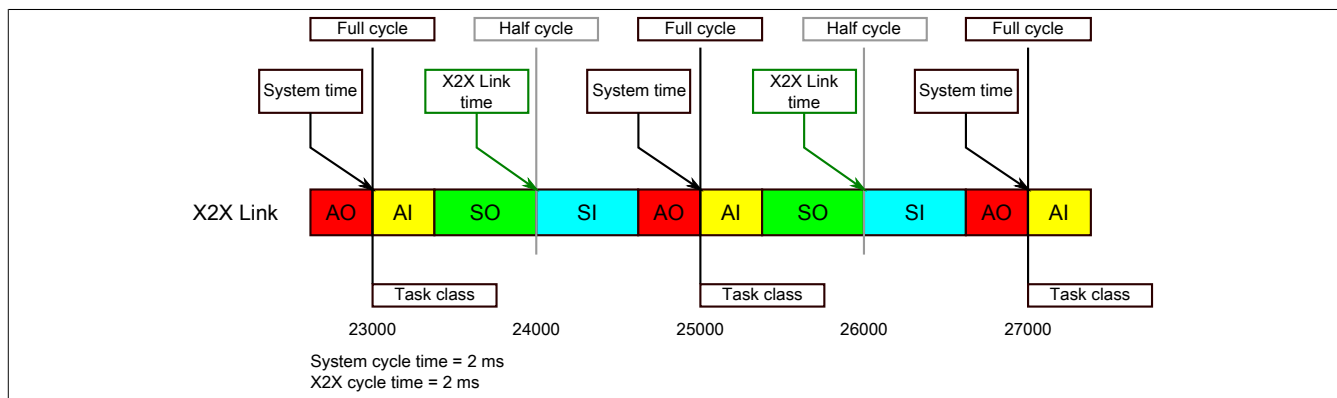

The reference time point on the X2X Link network is always calculated at the half cycle of the X2X Link cycle. This results in a difference between the system time and the X2X Link reference time point when the reference time is read out.

In the example above, this results in a difference of 1 ms, i.e. if the system time and X2X Link reference time are compared at time 25000 in the task, then the system time returns the value 25000 and the X2X Link reference time returns the value 24000.

### 4.7.1.3 POWERLINK - Reference time point

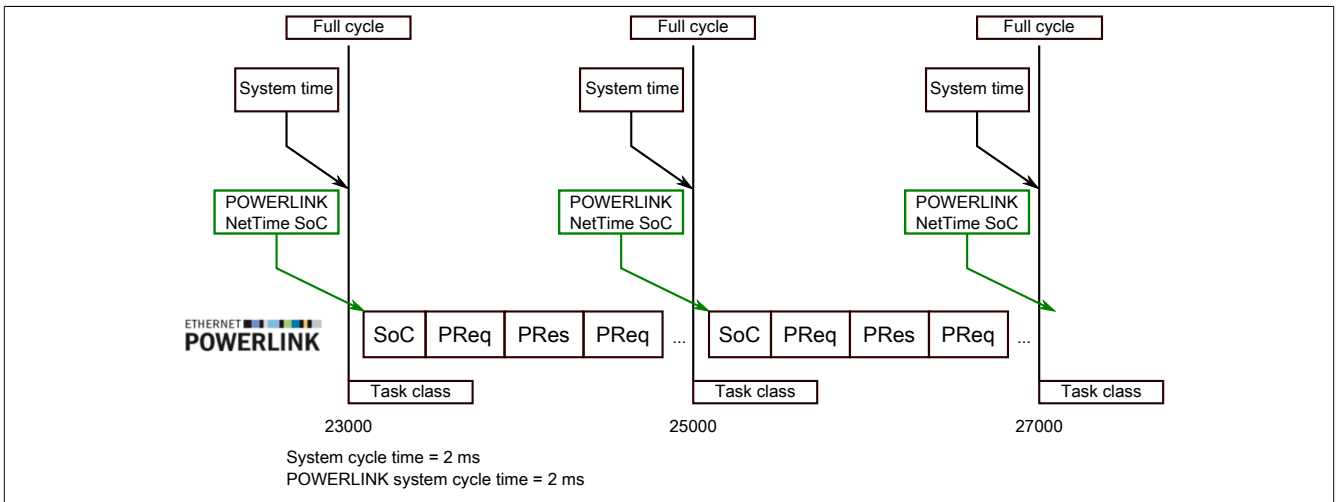

The reference time point on the POWERLINK network is always calculated at the start of cycle (SoC) of the POWERLINK network. The SoC starts 20 μs after the system clock due to the system. This results in the following difference between the system time and the POWERLINK reference time:

$$\text{POWERLINK reference time} = \text{System time} - \text{POWERLINK cycle time} + 20 \mu\text{s}.$$

In the example above, this means a difference of 1980 μs, i.e. if the system time and POWERLINK reference time are compared at time 25000 in the task, then the system time returns the value 25000 and the POWERLINK reference time returns the value 23020.

### 4.7.1.4 Synchronization of system time/POWERLINK time and I/O module

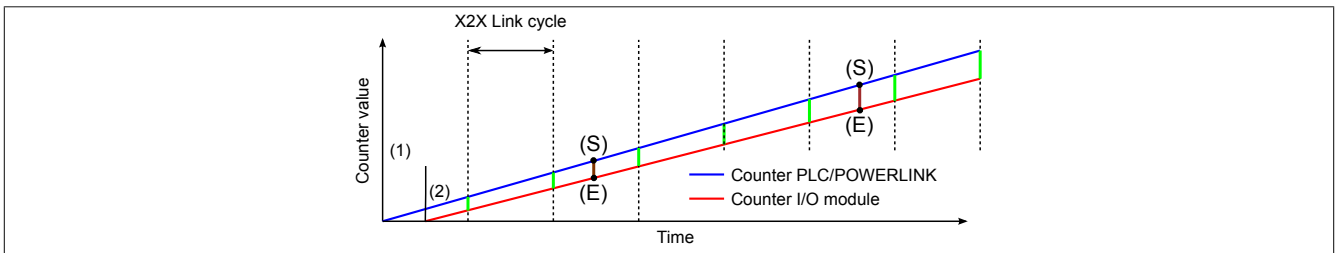

At startup, the internal counters for the controller/POWERLINK (1) and the I/O module (2) start at different times and increase the values with microsecond resolution.

At the beginning of each X2X Link cycle, the controller or POWERLINK network sends time information to the I/O module. The I/O module compares this time information with the module's internal time and forms a difference (green line) between the two times and stores it.

When a NetTime event (E) occurs, the internal module time is read out and corrected with the stored difference value (brown line). This means that the exact system moment (S) of an event can always be determined, even if the counters are not absolutely synchronous.

**Note**

The deviation from the clock signal is strongly exaggerated in the picture as a red line.

## 4.7.2 Timestamp functions

NetTime-capable modules provide various timestamp functions depending on the scope of functions. If a timestamp event occurs, the module immediately saves the current NetTime. After the respective data is transferred to the controller, including this precise moment, the controller can then evaluate the data using its own NetTime (or system time), if necessary.

### 4.7.2.1 Time-based inputs

NetTime Technology can be used to determine the exact moment of a rising edge at an input. The rising and falling edges can also be detected and the duration between 2 events can be determined.

#### Information:

**The determined moment always lies in the past.**

### 4.7.2.2 Time-based outputs

NetTime Technology can be used to specify the exact moment of a rising edge on an output. The rising and falling edges can also be specified and a pulse pattern generated from them.

#### Information:

**The specified time must always be in the future, and the set X2X Link cycle time must be taken into account for the definition of the moment.**

### 4.7.2.3 Time-based measurements

NetTime Technology can be used to determine the exact moment of a measurement that has taken place. Both the starting and end moment of the measurement can be transmitted.

## 4.8 Minimum cycle time

The minimum cycle time specifies how far the bus cycle can be reduced without communication errors occurring. It is important to note that very fast cycles reduce the idle time available for handling monitoring, diagnostics and acyclic commands.

Minimum cycle time
200 $\mu$ s

## 4.9 Minimum I/O update time

The minimum I/O update time specifies how far the bus cycle can be reduced so that an I/O update is performed in each cycle.

Minimum I/O update time
200 $\mu$ s