

Operation Instructions | EN

AM8000 and AM8500

Synchronous Servomotors

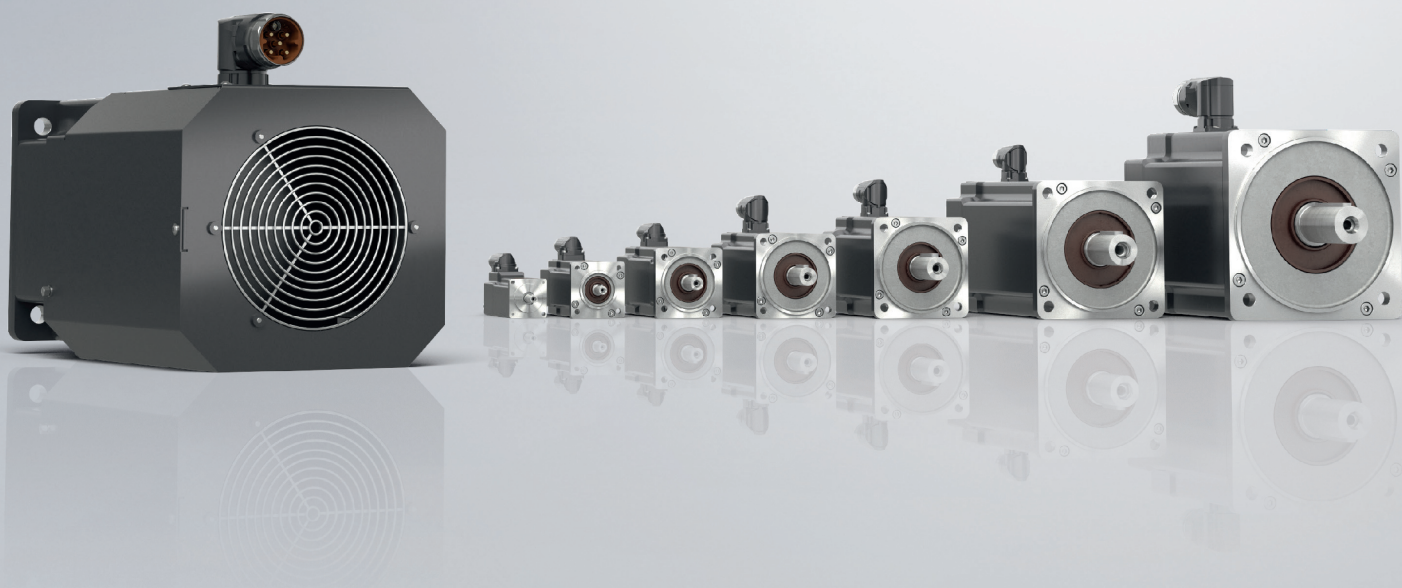

Documentation notes	5
Disclaimer	5
Version numbers	7
Scope of the documentation	7
Staff qualification	8
Safety and instruction	10
Explanation of symbols	10
Beckhoff Services	12
For your safety	14
Safety pictograms	14
General safety instructions	15
Product overview	17
Name plate	18
Type key	19
Product characteristics	21
Ordering options	23
Intended use	25
Technical data	26
Definitions	26
Data for operation and environment	28
AM801x	30
AM802x	33
AM803x & AM853x	36
AM804x & AM854x	40
AM805x & AM855x	44
AM806x & AM856x	55
AM807x	66
Scope of supply	78
Packaging	78
Transport and storage	79
Conditions	79
Transport	80
Long-term storage	82
Technical description	83
Mounting position	83
Feedback	84
Protection equipment	85
Shaft end A	86
Power derating	87
Mechanical installation	88
Flange mounting	88
Output elements	89
Fan cover [+].	93
Electrical installation	95
Connection technology	95
Connector assignment	103
Commissioning	106
Before commissioning	106
During commissioning	106
Prerequisites during operation	107

Table of contents

After operation	107
Maintenance and cleaning	108
Cleaning materials	108
Intervals	110
Accessories	111
Connection cables	111
iTec extension.....	111
speedtec extension.....	111
Shaft sealing ring	112
Gear unit.....	112
Fault correction.....	113
Decommissioning.....	117
Disassembly	117
Disposal	118
Guidelines and Standards	119
Standards	119
Guidelines.....	119
Test centers	119
EU conformity	120
CCC conformity	120
UL conformity.....	120
Index	121

Disclaimer

Beckhoff products are subject to continuous further development. We reserve the right to revise the operating instructions at any time and without prior announcement. No claims for the modification of products that have already been supplied may be made on the basis of the data, diagrams and descriptions in these operating instructions.

Trademarks

Beckhoff®, TwinCAT®, TwinCAT/BSD®, TC/BSD®, EtherCAT®, EtherCAT G®, EtherCAT G10®, EtherCAT P®, Safety over EtherCAT®, TwinSAFE®, XFC®, XTS® and XPlanar® are registered and licensed trademarks of Beckhoff Automation GmbH.

The use of other brand names or designations by third parties may lead to an infringement of the rights of the owners of the corresponding designations.

Patents

The EtherCAT technology is protected by patent rights through the following registrations and patents with corresponding applications and registrations in various other countries:

- EP1590927
- EP1789857
- EP1456722
- EP2137893
- DE102015105702



EtherCAT® is a registered trademark and patented technology, licensed by Beckhoff Automation GmbH.

Limitation of liability

All components in this product as described in the operating instructions are delivered in a specific configuration of hardware and software, depending on the application regulations. Modifications and changes to the hardware or software configuration that go beyond the documented options are prohibited and nullify the liability of Beckhoff Automation GmbH & Co. KG.

The following is excluded from the liability:

- Failure to observe these operating instructions
- Improper use
- Use of untrained personnel
- Use of unauthorized spare parts

Copyright

© Beckhoff Automation GmbH & Co. KG, Germany

The copying, distribution and utilization of this document as well as the communication of its contents to others without express authorization is prohibited. Offenders will be held liable for the payment of damages.

We reserve all rights in the event of registration of patents, utility models and designs.

Version numbers



Provision of revision levels

On request, you can obtain a list of revision levels for changes in the operating instructions.

- Send your request to: motion-documentation@beckhoff.de

Origin of the document

These operating instructions were originally written in German. All other languages are derived from the German original.

Product features

Only the product properties specified in the current operating instructions are valid. Further information given on the product pages of the Beckhoff homepage, in emails or in other publications is not authoritative.

Scope of the documentation

Apart from these operating instructions, the following documents are part of the overall documentation:

Documentation	Definition
Short information: Motor	Accompanying document with general instructions for handling the motors. This is included with every product.
Short information fan cover [+]	Fan cover installation description [+]

Staff qualification

These operating instructions are intended for trained control and automation specialists with knowledge of the applicable and required standards and directives.

Specialists must have knowledge of drive technology and electrical equipment as well as knowledge of safe working on electrical systems and machines. This includes knowledge of proper setup and preparation of the workplace as well as securing the working environment for other persons.

The operating instructions published at the respective time of each installation and commissioning is to be used. The products must be used in compliance with all safety requirements, including all applicable laws, regulations, provisions and standards.

Instructed person

Instructed persons have a clearly defined task area and have been informed about the work to be carried out. Instructed persons are familiar with:

- the necessary protective measures and protective devices
- the intended use and risks that can arise from use other than for the intended purpose

Trained person

Trained persons meet the requirements for instructed persons. Trained persons have additionally received training from the machine builder or vendor:

- machine-specific or
- plant-specific

Trained specialists

Trained specialists have received specific technical training and have specific technical knowledge and experience. Trained specialists can:

- apply relevant standards and directives
- assess tasks that they have been assigned
- recognize possible hazards
- prepare and set up workplaces

Qualified electricians

Qualified electricians have comprehensive technical knowledge gained from a course of study, an apprenticeship or technical training. They have an understanding of control technology and automation. They are familiar with relevant standards and directives. Qualified electricians can:

- independently recognize, avoid and eliminate sources of danger
- implement specifications from the accident prevention regulations
- assess the work environment
- independently optimize and carry out their work

Safety and instruction

Read the contents that refer to the activities you have to perform with the product. Always read the chapter For your safety in the operating instructions. Observe the warnings in the chapters so that you can handle and work with the product as intended and safely.

Explanation of symbols

Various symbols are used for a clear arrangement:

- ▶ The triangle indicates instructions that you should execute.
- The bullet point indicates an enumeration.
- [...] The square brackets indicate cross-references to other text passages in the document.
- [1] The number in the square brackets refers to the position in the adjacent figure.
- [+] The plus sign in square brackets indicates ordering options and accessories.

In order to make it easier for you to find text passages, pictograms and signal words are used in warning notices:

DANGER

Failure to observe will result in serious or fatal injuries.

WARNING

Failure to observe may result in serious or fatal injuries.

CAUTION

Failure to observe may result in minor or moderate injuries.



Notes are used for important information on the product. The possible consequences of failure to observe these include:

- Malfunctions of the product
- Damage to the product
- Damage to the environment



Information

This sign indicates information, tips and notes for dealing with the product or the software.



Examples

This symbol shows examples of how to use the product or software.



QR-Codes

This symbol shows a QR code, via which you can watch videos or animations. Internet access is required in order to use it.

You can read the QR code, for example, with the camera of your smartphone or tablet. If your camera doesn't support this function you can download a free QR code reader app for your smartphone. Use the Appstore for Apple operating systems or the Google Play Store for Android operating systems.

If you cannot read the QR code on paper, make sure that the lighting is adequate and reduce the distance between the reading device and the paper. In the case of documentation on a monitor screen, use the zoom function to enlarge the QR code and reduce the distance.

Beckhoff Services

Beckhoff and the worldwide partner companies offer comprehensive support and service.

Support services

Beckhoff Support offers technical advice on the use of individual Beckhoff products and system planning. Our support engineers offer you competent assistance, for comprehension questions as well as for commissioning.

 +49 5246 963-157

 support@beckhoff.com

 www.beckhoff.com/en-en/support/our-support-services/

Training offerings

We offer worldwide training courses for our products and technologies, always concentrating on direct local contact with our customers. Please note that we offer both classroom and online training courses.

 +49 5246 963-5000

 training@beckhoff.com

 www.beckhoff.com/en-en/support/training-offerings/

Service offerings

Our service experts support you worldwide in all areas of after-sales service.

 +49 5246 963-157

 service@beckhoff.com

 www.beckhoff.com/en-en/support/our-service-offerings/

Headquarters Germany

Beckhoff Automation GmbH & Co. KG
Hülshorstweg 20
33415 Verl, Germany

 +49 5246 963-0

 info@beckhoff.com

 www.beckhoff.com/en-en/

A detailed overview of our worldwide locations can be found online at Global presence.

 www.beckhoff.com/en-en/company/global-presence/

Downloadfinder

Our download finder contains all the files we offer for download: from our application reports to our technical documentation and configuration files.

 www.beckhoff.com/documentations

Read this chapter containing general safety information. The chapters in these operating instructions also contain warning notices. Always observe the safety instructions for your own safety, the safety of other persons and the safety of the product.

When working with control and automation products, many dangers can result from careless or incorrect use. Work particularly thoroughly, not under time pressure and responsibly towards other people.

Safety pictograms

You will find safety symbols on Beckhoff products and packaging. The symbols may be glued, printed, or lasered on and may vary depending on the product. They serve to protect people and to prevent damage to the products. Safety symbols may not be removed and must be legible for the user.

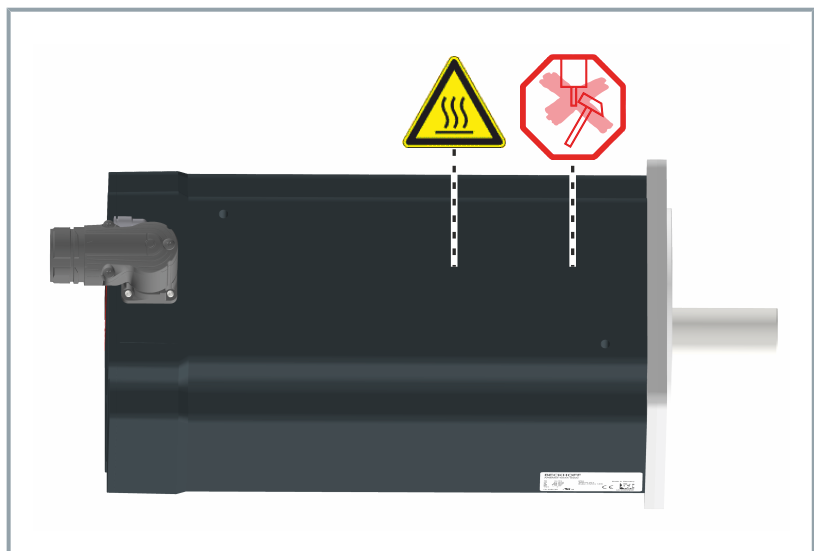

Warning of hot surface

During and after operation there is a risk of burns at the motor housing from hot surfaces above 60 °C. Allow the motor housing to cool down for the specified time, at least 15 minutes.



Avoid shocks to the shaft

Impacts on the shaft may cause the maximum permissible axial and radial values to be exceeded. Optical encoder systems can thus be destroyed.

General safety instructions

This chapter provides you with instructions on safety when handling the product. This product is not capable of stand-alone operation and is therefore categorized as an incomplete machine. The product must be installed in a machine or plant by the machine manufacturer. Read the documentation prepared by the machine manufacturer.

Before operation

Protective equipment

Do not remove or bypass any protective devices. Check all protective devices before operation. Make sure that all emergency switches are present at all times and can be reached by you and other people. People could be seriously or fatally injured by unprotected machine parts.

Shut down and secure the machine or plant

Shut down the machine or plant. Secure the machine or plant against being inadvertently started up.

Correctly ground electrical components or modules

Avoid electric shocks due to improper grounding of electrical components or modules. Ground all conductive components according to the specifications in the chapters "Electrical Installation" and "Mechanical Installation".

Keep the immediate environment clean

Keep your workplace and the surrounding area clean. Ensure safe working.

Check safety pictograms

Check whether the designated pictograms are on the product. Replace missing or illegible stickers.

Observe tightening torques

Mount and repeatedly check connections and components, complying with the prescribed tightening torques.

Use the original packaging only

When shipping, transporting, storing and packing, use the original packaging or non-conductive materials.

During operation

Do not work on live electrical parts

Never carry out any work on the motor or motor cable when they are live. Measure the voltage on the DC link test contacts DC+ und DC-. Only work on the motor when the voltage has dropped to < 50 V. Ensure that the protective conductor is connected properly. Never loosen electrical connections when live. Disconnect all components from the mains and secure them against being switched on again.

Do not touch hot surfaces

Check the cooling of the surfaces with a thermometer. Do not touch the components during and immediately after operation. Allow the components to cool sufficiently after switching off.

Avoid overheating

Operate the motor according to the technical specifications. Refer here to the chapter: "Technical data". Activate and monitor the temperature contact of the motor. Provide for sufficient cooling. Switch off the motor immediately if the temperature is too high.

Do not touch any moving or rotating components

Do not touch any moving or rotating components. Fasten all parts or components on the machine or plant.

After operation

De-energize and switch off components before working on them

Check the functionality of all safety-relevant devices. Secure the working environment. Secure the machine or plant against being inadvertently started up. Observe the chapter: "Decommissioning".

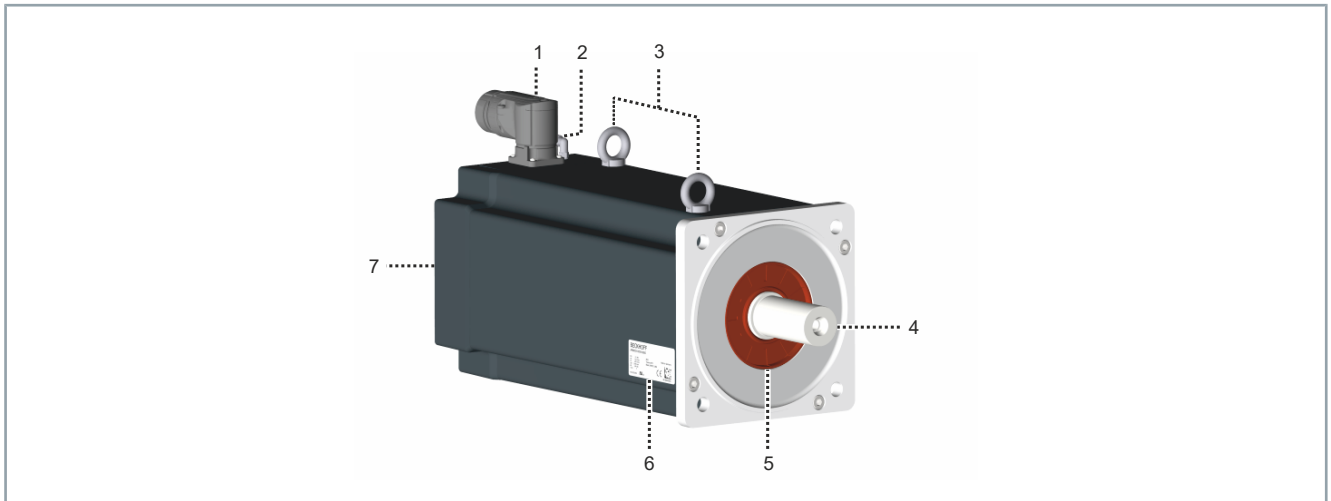

Number	Explanation
1	Power/feedback connection
2	Sealing air connection [+]
3	AM807x only: Eyebolt-installation eye
4	Motor shaft
5	Radial shaft-sealing ring [+]
6	Name plate
7	Motor housing

Name plate

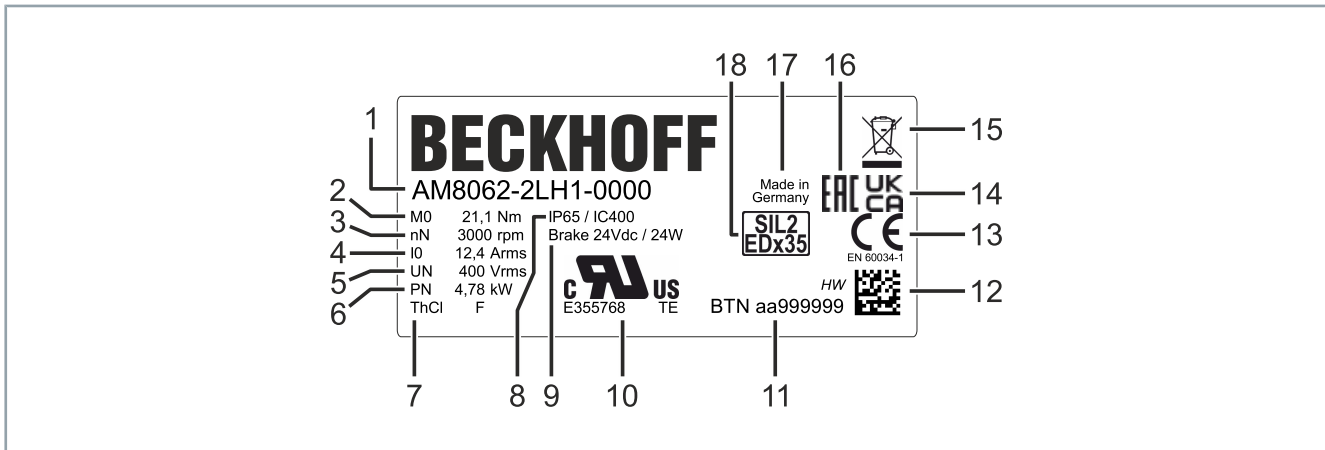

Item number	Explanation
1	Motor type
2	Standstill torque
3	Nominal speed
4	Standstill current
5	Nominal voltage
6	Nominal output
7	Insulation class
8	Protection class
9	Brake type
10	cURus approval for USA / CAN
11	Serial number
12	DataMatrix code
13	CE conformity
14	UKCA conformity
15	Disposal according to WEEE directive
16	EAC conformity
17	Country of manufacture
18	Safety Integrity Level

Type key

AM8 t u v-w x y z-a 00 0	Explanation
AM8	Product area Synchronous servomotors
t	Motor series 0 = standard 5 = increased mass moment of inertia
u	Flange size 1 = 40 mm 2 = 58 mm 3 = 72 mm 4 = 87 mm 5 = 104 mm 6 = 142 mm 7 = 194 mm
v	Overall length 1, 2, 3, 4
w	Shaft version 0 = smooth shaft 1 = shaft with groove and feather key according to DIN 6885 2 = shaft with radial shaft-sealing ring IP 65 and smooth shaft 3 = shaft with radial shaft-sealing ring IP 65, groove, feather key 4 = shaft with radial shaft-sealing ring IP 65, smooth shaft, sealing air connection 5 = shaft with radial shaft-sealing ring IP 65, groove, feather key, sealing air connection
x	Winding type A ... Z S = special winding
y	Feedback system 0 = resolver, two-pole 1 = OCT single-turn 2 = OCT multi-turn 3 = Hiperface single-turn 128 SinCos from F6 4 = Hiperface multi-turn 128 SinCos from F6 A = OCT single-turn 23-bit B = OCT multi-turn 23-bit G = OCT single-turn 24-bit, SIL 2 H = OCT multi-turn 24-bit, SIL 2 N = no feedback, "sensorless"
z	Holding brake 0 = without holding brake 1 = 24 V holding brake A = 24 V fan from F5; without holding brake B = 24 V fan from F5; 24 V holding brake C = 24 V fan from F5; IP 65; without holding brake D = 24 V fan from F5; IP 65; 24 V holding brake
a	Versions 0 = standard 1 = special version 9 = in case of AM805x, AM855x, flange and shaft compatible with AM3x5x
00	Not defined
0	Connection 0 = rotatable angular connector or terminal box

Flange sizes

Motor sizes matching the adapter for gear unit mounting

Beckhoff flange size	AM3000	AM3100	AM3500	AM8000	AM8100	AM8500
F1	AM301x	AM311x	-	AM801x	AM811x	-
F2	AM302x	-	-	AM802x	AM812x	-
Exception	-	AM312x	-	-	AM812x- xxxx-9	-
F3	AM303x	-	-	AM803x	AM813x	AM853x
F4	AM304x	-	AM354x	AM804x	AM814x	AM854x
F5	-	-	-	AM805x	-	AM855x
Exception	AM305x	-	AM355x	AM805x- xxxx-9	-	-
F6	AM306x	-	AM356x	AM806x	-	AM856x
F7	AM307x	-	-	AM807x	-	-
Exception	AM308x	-	-	-	-	-

Product characteristics

Brushless three-phase synchronous motors

Brushless three-phase synchronous motors have no electrical contact between rotor and stator. This means that the motor has no slip rings or commutators, which facilitates longer service life of the motor.

Neodymium permanent magnets

The magnets installed in the motor are permanent magnets. Neodymium is a hard magnetic material that enables the precise and highly dynamic positioning of the motors.

Three-phase stator winding

The three-phase winding in the stator reduces the amount of material required while maintaining the same electrical output. All phase angles are 120°.

Electronic commutation in the servo drive

The commutation of the motor is done electronically. The three coil turns are supplied from a bridge circuit.

Thermal contacts

A thermal contact LPTC-600 is installed to monitor and measure the winding temperature and to protect the motor against overheating. This can be read out by the user. No thermal contact is installed in the AM801x series.

Temperature warning and switch-off:

- Motor warning temperature at 120 °C
- Motor switch-off temperature at 140 °C

Holding brake [+]

The motors can be equipped as an option with permanent magnet holding brakes. These operate according to the quiescent current principle and open at a voltage of $24 V_{DC} +6/-10 \%$ with $> 10,000,000$ switching cycles.

The installed holding brake is not suitable for service braking, since there is no monitoring for wear and functionality by the servo drive and the configuration. This applies in particular to vertical axes.



Safety measures for vertical axes must be applied

When operating vertical axes, appropriate additional measures must be taken; for example, including but not only:

- additional redundant brake units
- mechanical safeguards or interlocks
- attachment of a balancing weight

Permanent magnet holding brakes alone are not approved for the protection of persons. In consideration of ISO 13849-1 and 13849-2, additional precautions must be taken for personal protection.

If the voltage is interrupted by emergency stop or power failure, the holding brake is conditionally permissible as a service brake. You can perform a maximum of 2000 emergency stops from a maximum of 3000 rpm with a maximum of three times the intrinsic inertia of the motor. These maximum values may vary due to increased load inertia.

The function of the holding brake can be checked with a torque wrench or with TwinCAT Scope.

Ordering options

Ordering options are defined via the type key and must be ordered separately. It is not possible to fit one at a later date.

Feather key

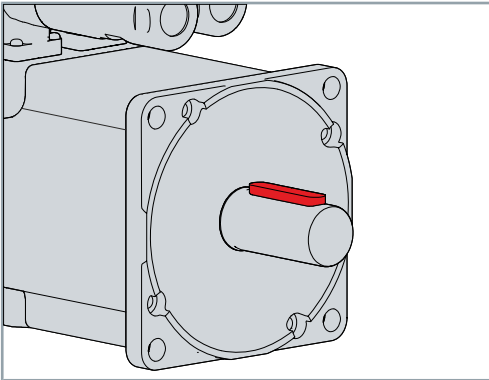

A feather key transmits torque to an output element.

The motors are available with feather key groove and inserted feather key according to DIN6885/ISO2491. The rotor is balanced with half a feather key according to DIN ISO 21940-32:2012-08.

Holding brake

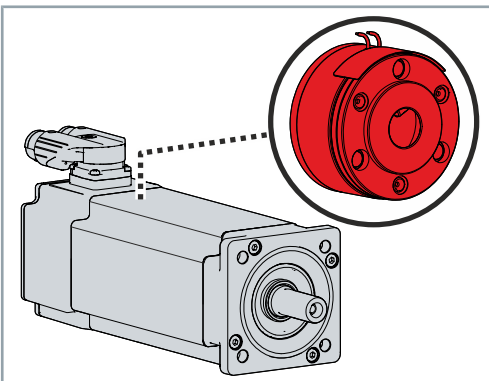

A holding brake blocks the rotor in the de-energized state. The holding brake increases the motor length and the rotor moment of inertia. The holding brake cannot be retrofitted and is mounted on the B bearing side of the motor.

Fan cover

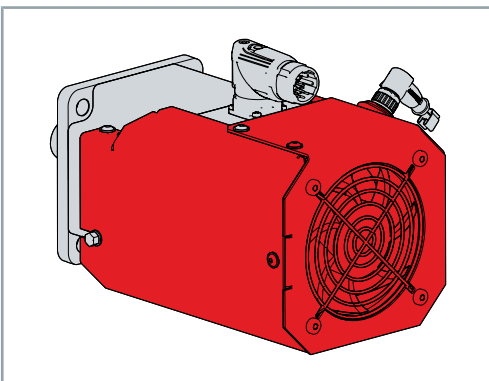

The purpose of the fan cover is the external cooling of the motors. It therefore increases the performance data of the motor.

This ordering option is available for motors of the following series:

- AM8x5x and AM8x5x-xxxx-9000; flange compatible with AM3x5x
- AM8x6x and
- AM807x

Sealing air connection

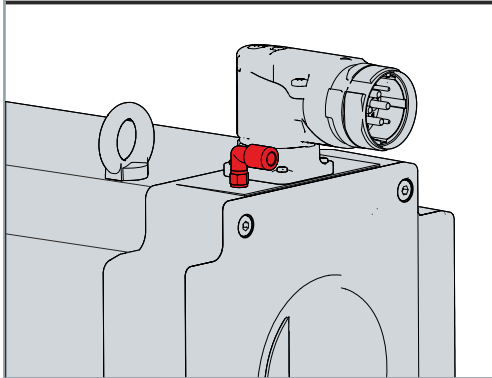
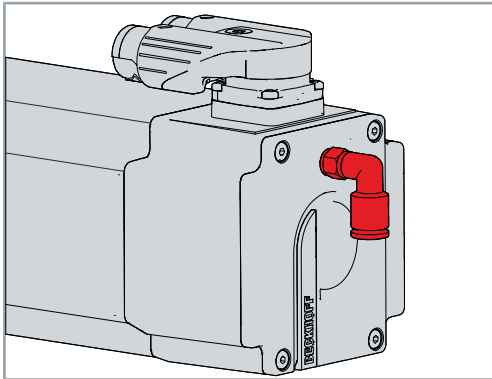

Ingress of fluids or dust at different temperature ranges can be prevented by a separate sealing air connection with a defined overpressure. The overpressure is achieved by connection to a regulated compressed air system. It is installed together with an axial shaft sealing ring.

A sealing air connection is recommended for:

- Critical installation locations with extreme dust exposure
- Motors with permanent and direct fluid contact

Important

In the horizontal mounting position IM V3, liquid can accumulate permanently on the motor flange and penetrate into the motor. Even a sealing air connection cannot completely prevent the liquid from entering.

An air hose provided by the customer must be connected to a suitable regulated pressure reducer. The compressed air must be free of oil and dust.

Minimum requirements and technical data:	
Compressed air requirement	according to DIN ISO 8573-1 Class 3:2010 [A:B:C]
Operating pressure	0.1 ± 0.05 bar
Maximum pressure	0.3 bar
Air connection	Quick-release coupling
Required air line	e.g. PA hose 6 mm x 4 mm

Intended use

The synchronous servomotors from the AM8000 & AM8500 series may be operated only for the intended activities defined in this documentation, taking into account the prescribed environmental conditions.

The components are installed in electrical plants or machines. Stand-alone operation of the components is not permitted.

The thermal protection contact incorporated in the motor windings must be analyzed and monitored on a regular basis.



Read the entire drive system documentation:

- This translation of the original instructions
- Original instructions for the AX5000 servo drives and/or the AX8000 multi-axis servo system
- Complete machine documentation provided by the machine manufacturer

Improper use

Any type of use that exceeds the permissible values from the technical data is regarded as inappropriate and is thus prohibited.

Beckhoff servomotors of the AM8000 & AM8500 series Beckhoff are not suitable for use in the following areas:

- ATEX zones without suitable housing
- Areas with aggressive environments, for example aggressive gases or chemicals

The relevant standards and directives for EMC interference emissions must be complied with in residential areas.

Definitions



Characteristic torque and speed curves

Detailed information on characteristic curves can be found under: TE5910 | TwinCAT 3 Motion Designer

Performance data external fan

Detailed information on the performance data of the external fan can be found in chapter:

"Performance data of the external fan", [Page 94]

All data, with the exception of the voltage constant, are based on 40 °C ambient temperature and 100 K overtemperature of the winding. The data can have a tolerance of +/- 10 %.

By default, a large part of the heat generated in the motor is dissipated into the machine bed via the A-flange. With an attached gear unit, this direct heat dissipation is interrupted and reduces the amount of heat that the motor can dissipate via the flange. This effect can be further enhanced by the gear unit's self-heating. This means that a power reduction of up to 20% can occur when a gear unit is mounted. This configuration leads to a reduction of the nominal output.

Technical terms

This chapter provides information on various technical terms and their meaning.

Standstill torque M_0 [Nm]

Torque, also referred to as starting torque, that the motor can generate at standstill. It can be maintained indefinitely at a speed $n < 100 \text{ min}^{-1}$ and rated ambient conditions.

Rated torque M_n [Nm]

The torque that the motor delivers when it is operated at nominal speed and nominal current. Can be output in continuous operation S1 for an unlimited period of time.

Standstill current $I_{0\text{rms}}$ [A]

Sinusoidal current RMS value. This is consumed at a speed of $n < 100 \text{ min}^{-1}$ in order to generate the standstill torque.

Peak current/pulse current $I_{0\text{max}}$ [A]

Sinusoidal peak current RMS value. Corresponds to approx. five times the standstill current and three times for AM806x, AM856x and AM807x. The configured peak current of the servo drive used must be less or equal.

Torque constant $K_{T\text{rms}}$ [Nm/A]

Indication of the torque in Nm generated by the motor per ampere of standstill current. $M_0 = I_0 \times K_T$ applies

Voltage constant $K_{E_{rms}}$ [mVmin]

Indication of the induced motor EMF at 20 °C, based on 1000 rpm. This is specified as the sine RMS value between two terminals.

Rotor moment of inertia J [kgcm²]

Measure of the acceleration capacity of the motor. For example, at J_0 the acceleration time t_b from 0 to 3000 min⁻¹ can be calculated based on the following formula:

$$t_b[S] = \frac{3000 \cdot 2 \pi}{M_0 \cdot 60 s} \cdot \frac{m^2}{10^4 cm^2} \cdot J$$

with M_0 in Nm and J in kgcm²

Thermal time constant t_{TH} [min]

Specification of the heating time of the cold motor under load with I_0 until an overtemperature of 0.63 x 100 Kelvin is reached. This temperature rise happens in a much shorter time when the motor is loaded with the peak current.

**Release delay time/application delay time of the brake t_{BRH} [ms]/
 t_{BRL} [ms]**

Specification of the response times of the holding brake [+] when operated with the nominal voltage

Winding inductance L [mH]

Indication of the motor inductance. It is the average value for one motor revolution, with two energized phases, at 1 kHz. Saturation of the motor must be taken into account.

Data for operation and environment

Beckhoff products are designed for operation under certain environmental conditions, which vary according to the product. The following specifications must be observed for operation and environment in order to achieve the optimum service life of the products.



Operate the motor only under the specified conditions

Operate motors only under the operating and environmental conditions specified in this chapter. This ensures a long service life and proper operation.

Temperatures above 40 °C and encapsulated installation can shorten the service life of the servomotor.

Environmental requirements	
Climate category - operation	2K3 according to EN 60721
Ambient temperature during operation	+5 °C to +40 °C, extended temperature range
Ambient temperature during transport	-25 °C to +70 °C, maximum fluctuation 20 K/hour
Ambient temperature during storage	-25 °C to +55 °C, maximum fluctuation 20 K/hour
Power derating	No derating at installation altitudes higher than 1000 m above sea level and a temperature reduction of 10 K/1000 m.
Derating according to installation altitude	At installation heights higher than 1000 m above sea level and 40 °C: 6 % at 2000 m above sea level 17 % at 3000 m above sea level 30 % at 4000 m above sea level 55 % at 5000 m above sea level
Permissible humidity in operation	95 % relative humidity, no condensation
Permissible humidity during transport and storage	5 % to 95 % relative humidity, no condensation

Specifications for intended use	
Cooling	Convection
Insulation material class	F according to IEC 60085, UL1446 class F
Protection rating	Housing: IP 65; IP54 for AM801x Shaft feedthrough: IP54 Shaft feedthrough with double-lipped PTFE shaft sealing ring with FDA approval: IP65
Feedback system	absolute encoder, single-turn and multi-turn OCT, resolver
Vibration resistance	50 g, 10...2000 Hz according to EN 60068-2-6
Shock resistance	100 g, 6 ms according to EN 60068-2-27
EMC requirements	conforms to EN 61800-3:2004 + A1:2012
Approvals	CE, cURus EAC See chapter: Guidelines and Standards
Vibration class ≤ 1800 [rpm]	
Maximum relative vibration displacement	90 µm
Maximum run-out	23 µm
Vibration class > 1800 [rpm]	
Maximum relative vibration displacement	65 µm
Maximum run-out	16 µm

AM801x

Electrical data	AM80xx		
	11B	12C	13D
Standstill torque M_0 [Nm]	0.20	0.38	0.52
Standstill current I_{orms} [A]	0.76	1.30	1.65
Maximum mechanical speed N_{max} [min ⁻¹]	10,000		
Maximum nominal mains voltage UN [VAC]	250		
Peak current I_{0max} [A]	2.30	4.55	5.90
Peak torque M_{0max} [Nm]	0.68	1.37	2.04
Torque constant K_{Trms} [Nm/A]	0.26	0.29	0.32
Voltage constant K_{Erms} [mV/min]	19	19.20	22.70
Winding resistance Ph-Ph R_{20} [Ω]	34.50	15	11.50
Winding inductance Ph-Ph, measured at 1 kHz L [mH]	21	10.50	9
Power supply $U_N = 115 V$			
Nominal speed N_n [min ⁻¹]	3500	4000	3500
Nominal torque M_n [Nm]	0.19	0.35	0.49
Nominal output P_n [kW]	0.07	0.15	0.18
Power supply $U_N = 230 V$			
Nominal speed N_n [min ⁻¹]	8000		
Nominal torque M_n [Nm]	0.18	0.33	0.45
Nominal output P_n [kW]	0.15	0.28	0.38
Nominal current I_n [A]	0.73	1.20	1.30
Connection technology	iTec		
<i>Reference flange aluminum 230 mm x 130 mm x 10 mm</i>			
Mechanical data	AM80xx		
	11	12	13
Rotor moment of inertia J [kgcm ²]	0.03	0.05	0.07
Rotor moment of inertia with brake J [kgcm ²]	0.06	0.08	0.09
Number of poles	6		
Static friction torque M_R [Nm]	0.0009	0.0018	0.0027
Thermal time constant t_{TH} [min]	9	9	10
Weight [kg]	0.55	0.64	0.79
Weight with brake [kg]	0.74	0.86	0.98
Flange	IEC standard/DIN 42955		
Fit	h7		
Tolerance class	N		
Protection rating			
Standard housing version	IP54		
Standard shaft feedthrough version	IP54		
Paint finishes			
Properties	acrylic powder-coated		
Color	Anthracite gray; RAL 7016		

Optional holding brake [+]	AM801x
Holding torque at 120 °C M_{BR} [Nm]	0.60
Supply voltage U_{BR} [V _{DC}]	24; +6 % to -10 %
Electrical power P_{BR} [W]	10
Current I_{on} [A]	0.30
Release delay time t_{BRH} [ms]	14
Application delay time t_{BRL} [ms]	8

Dimensional drawing

- All figures in millimeters

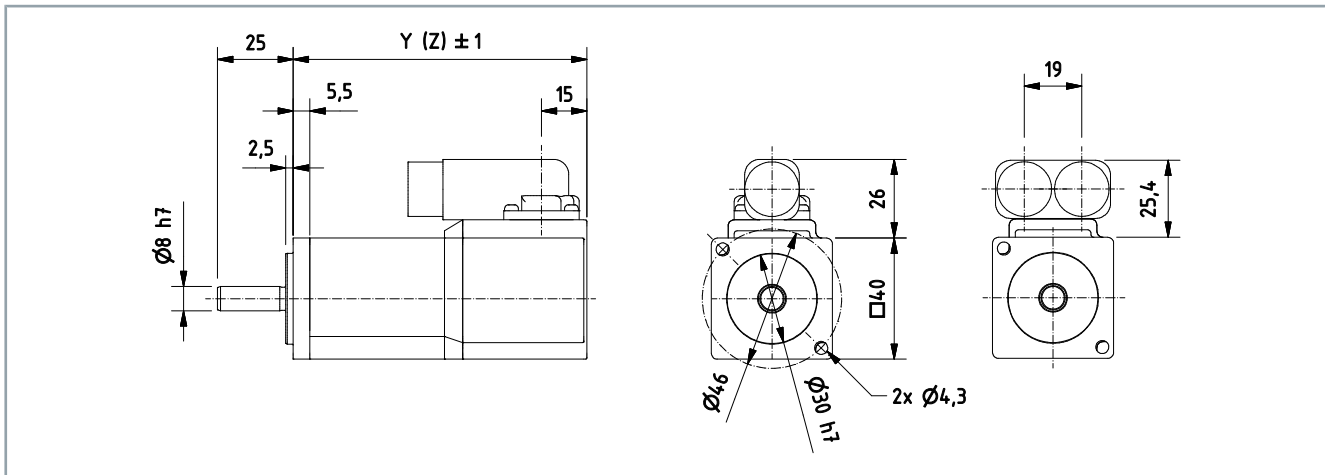

Motor	Y	Z-brake
AM8011	97	129
AM8012	117	149
AM8013	137	169

Feather key [+]

- Center bore according to DIN 332-D

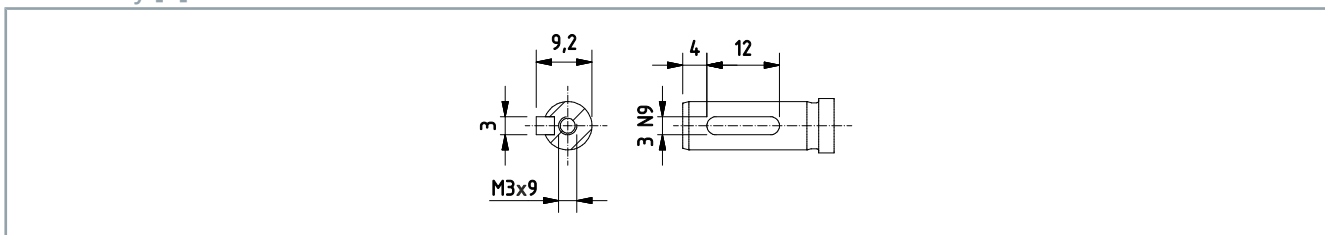

Force diagram



Beckhoff load/force calculator

The software represents axial and radial forces on the motor shaft. The following example shows an AM8011 without a holding brake.

- [Download load/force calculator](#)

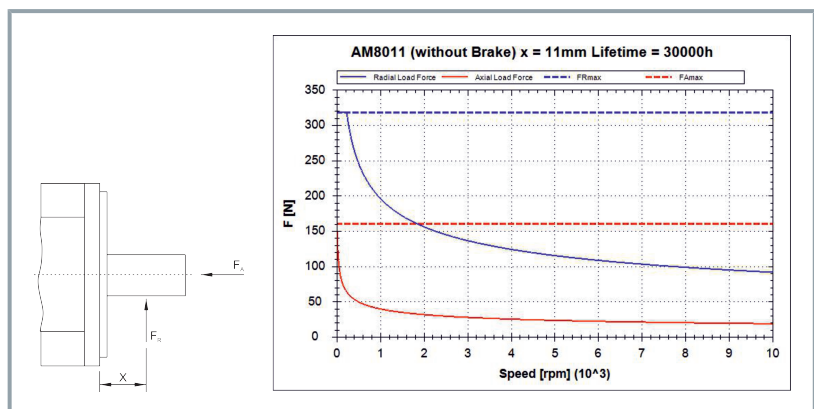

AM802x

Electrical data	AM80xx					
	21B	21D	22D	22E	23E	23F
Standstill torque M_0 [Nm]	0.50	0.50	0.80	0.80	1.20	1.20
Standstill current I_{orms} [A]	0.85	1.60	1.50	2.44	2.20	3.40
Maximum mechanical speed N_{max} [min ⁻¹]	12000					
Maximum nominal mains voltage U_N [V _{AC}]	480					
Peak current I_{0max} [A]	4.90	8.60	7.70	12.60	11.40	17.70
Peak torque M_{0max} [Nm]	2.68	2.67	4.18	4.18	6.36	6.37
Torque constant K_{Trms} [Nm/A]	0.59	0.31	0.53	0.33	0.55	0.35
Voltage constant K_{Erms} [mVmin]	42	23	41	25	43	25
Winding resistance Ph-Ph R_{20} [Ω]	39.40	12.80	13.20	5.10	8.50	3.60
Winding inductance Ph-Ph, measured at 1 kHz L [mH]	67	21.60	30.10	11.20	20.80	8.70
Power supply $U_N = 115$ V						
Nominal speed N_n [min ⁻¹]	1500	3500	2000	4000	2000	3500
Nominal torque M_n [Nm]	0.50	0.50	0.78	0.76	1.15	1.16
Nominal output P_n [kW]	0.08	0.18	0.16	0.32	0.24	0.43
Power supply $U_N = 230$ V						
Nominal speed N_n [min ⁻¹]	4000	8000	4500	8000	4500	8000
Nominal torque M_n [Nm]	0.50	0.50	0.75	0.70	1.10	1.00
Nominal output P_n [kW]	0.21	0.42	0.35	0.59	0.52	0.84
Power supply $U_N = 400$ V						
Nominal speed N_n [min ⁻¹]	8000	9000	8000	9000	8000	9000
Nominal torque M_n [Nm]	0.50	0.50	0.70	0.65	1	0.90
Nominal output P_n [kW]	0.42	0.47	0.59	0.61	0.84	0.85
Nominal current I_n [A]	0.85	1.60	1.30	1.95	1.85	2.85
Power supply $U_N = 480$ V						
Nominal speed N_n [min ⁻¹]	9000					
Nominal torque M_n [Nm]	0.50	0.50	0.65	0.65	0.90	0.90
Nominal output P_n [kW]	0.47	0.47	0.61	0.61	0.85	0.85
Connection technology	iTec					
<i>Reference flange aluminum 230 mm x 130 mm x 10 mm</i>						

Technical data

Mechanical data	AM80xx		
	21	22	23
Rotor moment of inertia J [kgcm ²]	0.14	0.26	0.38
Rotor moment of inertia with brake J [kgcm ²]	0.21	0.33	0.45
Number of poles	6		
Static friction torque M _R [Nm]	0.002	0.004	0.006
Thermal time constant t _{TH} [min]	10	13	16
Weight [kg]	1	1.30	1.70
Weight with brake [kg]	1.16	1.66	1.96
Flange	IEC standard/DIN 42955		
Fit	j6		
Tolerance class	N		
Protection rating			
Standard housing version	IP65		
Standard shaft feedthrough version	IP54		
Shaft feedthrough with shaft sealing ring	IP65		
Paint finishes			
Properties	acrylic powder-coated		
Color	Anthracite gray; RAL 7016		
Optional holding brake [+]	AM802x		
Holding torque at 120 °C M _{BR} [Nm]	2		
Supply voltage U _{BR} [V _{DC}]	24; +6 % to -10 %		
Electrical power P _{BR} [W]	10		
Current I _{on} [A]	0.3		
Release delay time t _{BRH} [ms]	25		
Application delay time t _{BRL} [ms]	8		

Dimensional drawing

- All figures in millimeters

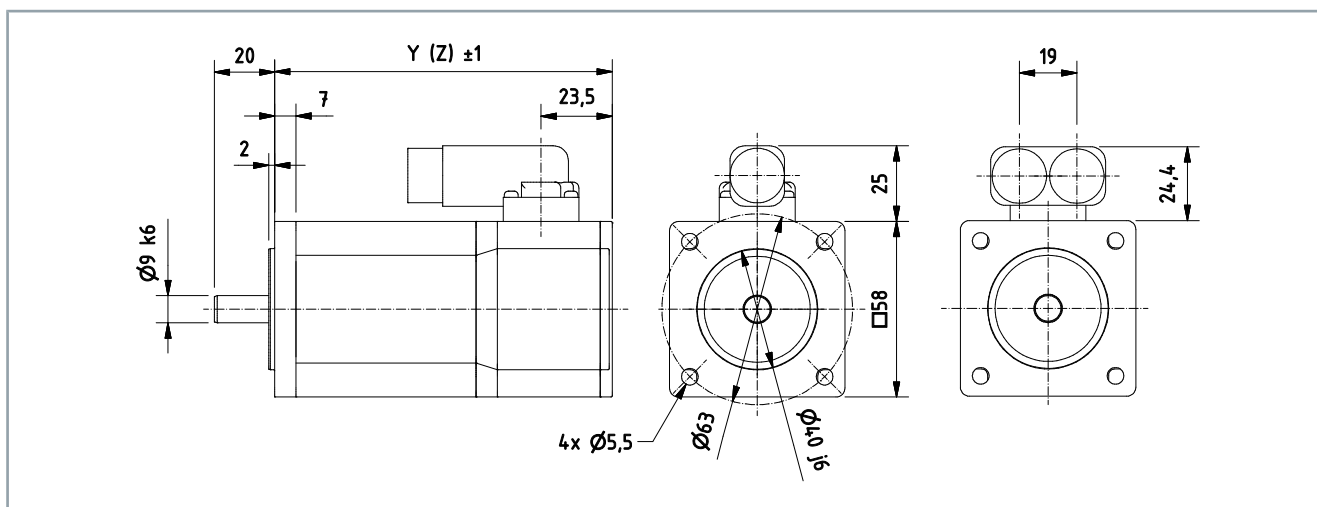

Motor	Y	Z-brake
AM8021	111.5	146
AM8022	133.5	168
AM8023	155.5	190

Feather key [+]

- Center bore according to DIN 332-D

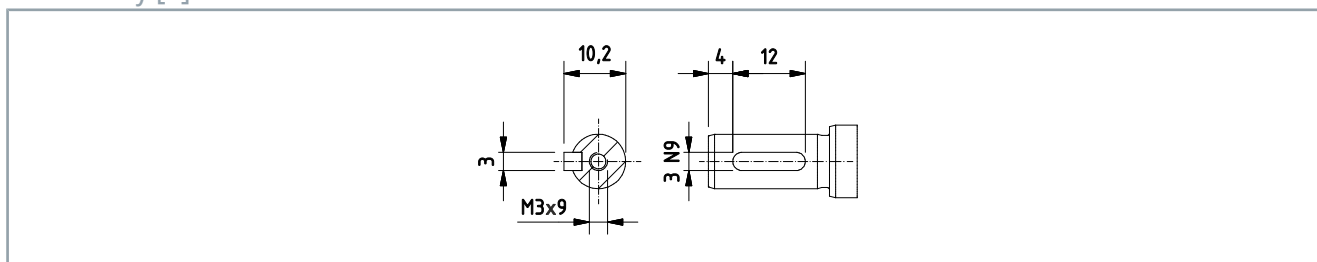

Force diagram



Beckhoff load/force calculator

The software represents axial and radial forces on the motor shaft. The following example shows an AM8022 without a holding brake.

- Download load/force calculator

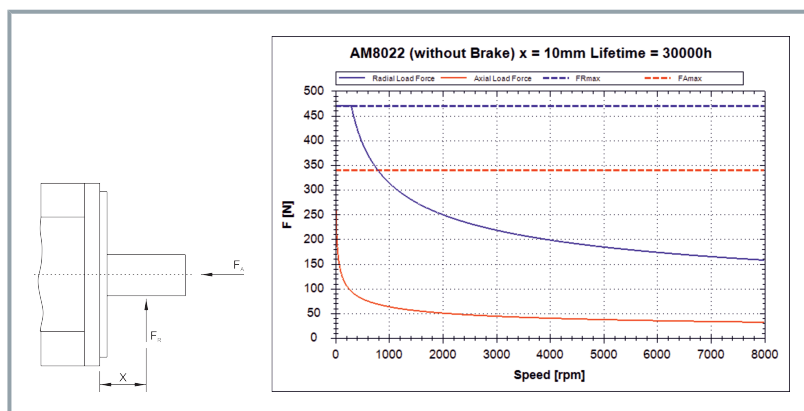

AM803x & AM853x

Electrical data	AM80xx and AM85xx				
	31C	31D	31F	32D	32E
Standstill torque M_0 [Nm]	1.37	1.38	1.40	2.38	2.37
Standstill current I_{orms} [A]	1	1.95	3.20	1.70	2.95
Maximum mechanical speed N_{max} [min ⁻¹]	10000				
Maximum nominal mains voltage U_N [V _{AC}]	480				
Peak current I_{0max} [A]	5.50	10.70	17.60	9.60	17.20
Peak torque M_{0max} [Nm]	6.10	6.07	6.07	11.66	11.66
Torque constant K_{Trms} [Nm/A]	1.37	0.71	0.44	1.40	0.80
Voltage constant K_{Erms} [mV/min]	99	50	30	100	56
Winding resistance Ph-Ph R_{20} [Ω]	51	12.60	5	21	6.50
Winding inductance Ph-Ph, measured at 1 kHz L [mH]	134	36	13.30	71.90	22.60
Power supply $U_N = 115$ V					
Nominal speed N_n [min ⁻¹]	400	1400	2700	600	1400
Nominal torque M_n [Nm]	1.36	1.38	1.37	2.37	2.34
Nominal output P_n [kW]	0.06	0.20	0.39	0.15	0.34
Power supply $U_N = 230$ V					
Nominal speed N_n [min ⁻¹]	1400	3300	6000	1500	3000
Nominal torque M_n [Nm]	1.35	1.36	1.34	2.34	2.30
Nominal output P_n [kW]	0.20	0.47	0.84	0.37	0.76
Power supply $U_N = 400$ V					
Nominal speed N_n [min ⁻¹]	3000	6000	9000	3000	6000
Nominal torque M_n [Nm]	1.34	1.33	1.30	2.30	2.20
Nominal output P_n [kW]	0.42	0.84	1.23	0.72	1.38
Nominal current I_n [A]	0.95	1.90	3	1.60	2.75
Power supply $U_N = 480$ V					
Nominal speed N_n [min ⁻¹]	3400	6800	9000	3400	6800
Nominal torque M_n [Nm]	1.33	1.32	1.30	2.26	2.10
Nominal output P_n [kW]	0.47	0.94	1.23	0.80	1.50
Connection technology	iTec				
Reference flange aluminum 230 mm x 130 mm x 10 mm					

Electrical data	AM80xx and AM85xx			
	32H	33E	33F	33J
Standstill torque M_0 [Nm]	2.37	3.20	3.22	3.22
Standstill current I_{0rms} [A]	5.10	2.10	4.10	6.80
Maximum mechanical speed N_{max} [min ⁻¹]	10000			
Maximum nominal mains voltage U_N [V _{AC}]	480			
Peak current I_{0max} [A]	29.50	12.90	24.60	39.80
Peak torque M_{0max} [Nm]	11.65	17.19	17.71	17.22
Torque constant K_{Tms} [Nm/A]	0.46	1.52	0.78	0.47
Voltage constant K_{Emms} [mVmin]	32	106	57	34
Winding resistance Ph-Ph R_{20} [Ω]	2.20	13.20	3.90	1.35
Winding inductance Ph-Ph, measured at 1 kHz L [mH]	7.70	46.30	14	4.90
Power supply $U_N = 115$ V				
Nominal speed N_n [min ⁻¹]	2700	600	1400	2700
Nominal torque M_n [Nm]	2.29	3.15	3.10	3.05
Nominal output P_n [kW]	0.65	0.20	0.45	0.86
Power supply $U_N = 230$ V				
Nominal speed N_n [min ⁻¹]	6000	1500	3000	5900
Nominal torque M_n [Nm]	2.10	3.10	3	2.70
Nominal output P_n [kW]	1.32	0.49	1	1.67
Power supply $U_N = 400$ V				
Nominal speed N_n [min ⁻¹]	9000	3000	6000	9000
Nominal torque M_n [Nm]	1.85	2.98	2.70	2.30
Nominal output P_n [kW]	1.74	0.94	1.70	2.17
Nominal current I_n [A]	4.10	2	3.60	5.10
Power supply $U_N = 480$ V				
Nominal speed N_n [min ⁻¹]	9000	3400	6800	9000
Nominal torque M_n [Nm]	1.85	2.95	2.60	2.30
Nominal output P_n [kW]	1.74	1.05	1.85	2.17
Connection technology	iTec			
<i>Reference flange aluminum 230 mm x 130 mm x 10 mm</i>				

Technical data

Mechanical data	AM8031	AM8531	AM8032	AM8532	AM8033	AM8533
Rotor moment of inertia J [kgcm ²]	0.47	1.67	0.85	2.05	1.23	2.44
Rotor moment of inertia with brake J [kgcm ²]	0.55	1.76	0.93	2.15	1.46	---
Number of poles	8					
Static friction torque M _R [Nm]	0.01	0.01	0.02	0.02	0.02	0.02
Thermal time constant t _{TH} [min]	24	24	26	26	28	28
Weight [kg]	1.80	2.40	2.40	3	3	3.60
Weight with brake [kg]	2.20	2.60	2.80	3.30	3.60	---
Flange	IEC standard/DIN 42955					
Fit	j6					
Tolerance class	N					
Protection rating						
Standard housing version	IP65					
Standard shaft feedthrough version	IP54					
Shaft feedthrough with shaft sealing ring	IP65					
Paint finishes						
Properties	acrylic powder-coated					
Color	Anthracite gray; RAL 7016					
Optional holding brake [+]	AM8031	AM8531	AM8032	AM8532	AM8033	AM8533
Holding torque at 120 °C M _{BR} [Nm]	2					3.5
Supply voltage U _{BR} [V _{DC}]	24; +6 % to -10 %					
Electrical power P _{BR} [W]	11					12
Current I _{on} [A]	0.33					0.36
Release delay time t _{BRH} [ms]	25					35
Application delay time t _{BRL} [ms]	8					15

Dimensional drawing

- All figures in millimeters

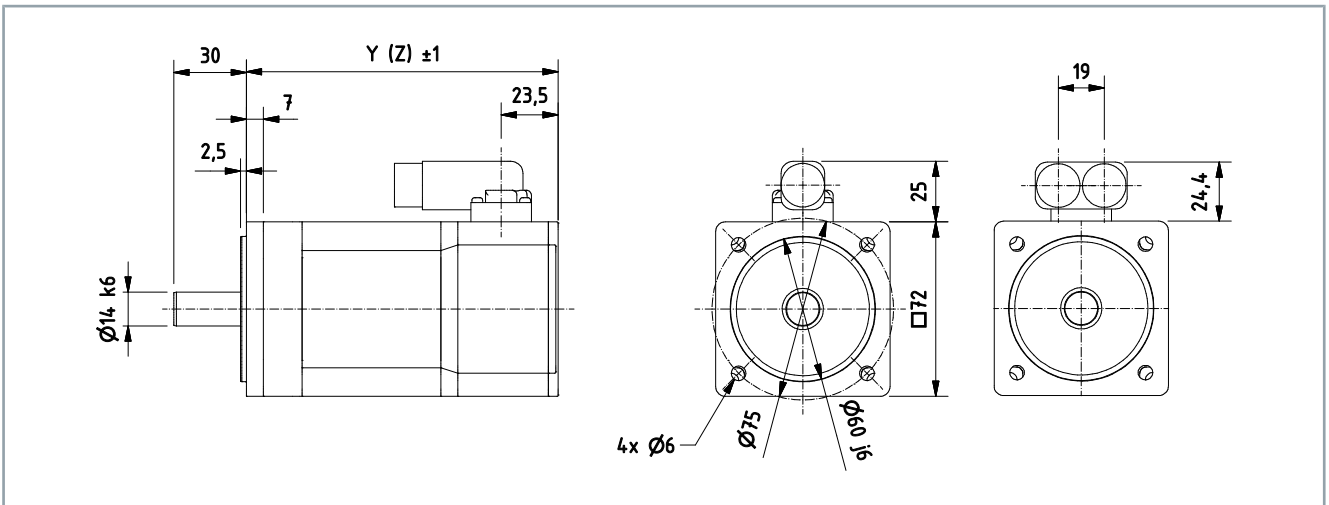

Motor	Y	Z-brake
AM8031	129	168
AM8032	154	194
AM8033	180	229
AM8531	168	194
AM8532	194	229
AM8533	229	--

Feather key [+]

- Center bore according to DIN 332-D

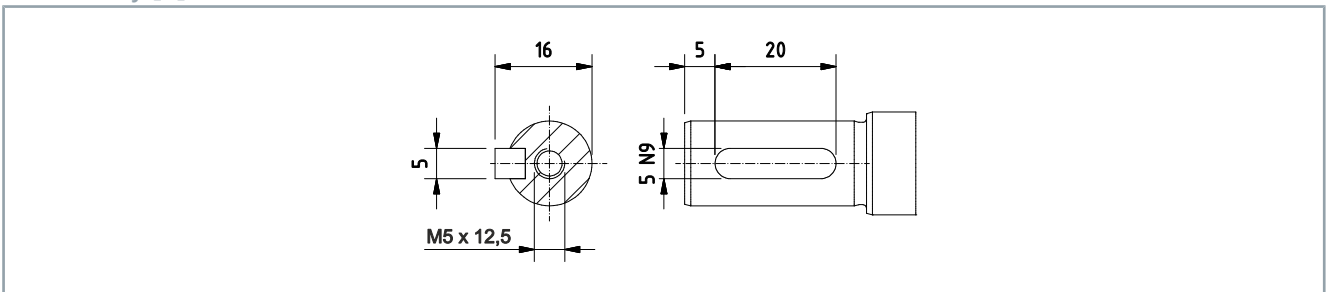

Force diagram



Beckhoff load/force calculator

The software represents axial and radial forces on the motor shaft. The following example shows an AM8032 without a holding brake.

- Download load/force calculator

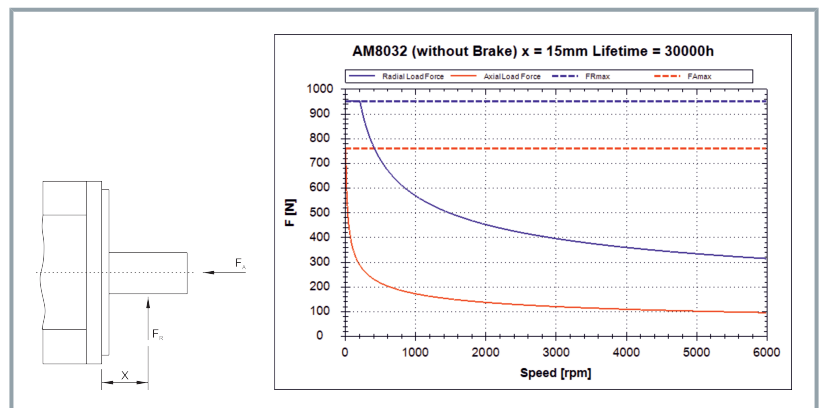

AM804x & AM854x

Electrical data	AM80xx and AM85xx				
	41D	41E	41H	42E	42F
Standstill torque M_0 [Nm]	2.37	2.45	2.40	4.10	4.10
Standstill current I_{orms} [A]	1.65	3	5.25	2.15	4.10
Maximum mechanical speed N_{max} [min ⁻¹]	9000				
Maximum nominal mains voltage U_N [V _{AC}]	480				
Peak current I_{0max} [A]	8.30	13.60	23.30	11.80	22.70
Peak torque M_{0max} [Nm]	9.67	9.14	9.14	18.94	18.90
Torque constant K_{Trms} [Nm/A]	1.43	0.81	0.45	1.90	1
Voltage constant K_{Erms} [mV/min]	101.0	56.00	33	128	68
Winding resistance Ph-Ph R_{20} [Ω]	22.50	6.10	2.21	14.20	3.70
Winding inductance Ph-Ph (measured at 1 kHz) L [mH]	83.10	25.00	8.50	64.90	17.40
Power supply $U_N = 115$ V					
Nominal speed N_n [min-1]	600	1300	2600	500	1200
Nominal torque M_n [Nm]	2.35	2.43	2.34	4.05	3.97
Nominal output P_n [kW]	0.15	0.33	0.64	0.21	0.50
Power supply $U_N = 230$ V					
Nominal speed N_n [min-1]	1500	3000	6000	1200	2800
Nominal torque M_n [Nm]	2.33	2.39	2.27	3.97	3.90
Nominal output P_n [kW]	0.37	0.75	1.43	0.50	1.14
Power supply $U_N = 400$ V					
Nominal speed N_n [min-1]	3000	6000	8000	2500	5000
Nominal torque M_n [Nm]	2.30	2.31	2.10	3.90	3.70
Nominal output P_n [kW]	0.72	1.45	1.76	1.02	1.94
Nominal current I_n [A]	1.60	2.90	4.60	2.05	3.80
Power supply $U_N = 480$ V					
Nominal speed N_n [min-1]	3400	6800	8000	2800	5700
Nominal torque M_n [Nm]	2.29	2.27	2.10	3.87	3.64
Nominal output P_n [kW]	0.82	1.62	1.76	1.13	2.17
Connection technology	M23-Speedtec				
Reference flange aluminum 230 mm x 130 mm x 10 mm					

Electrical data	AM80xx and AM85xx					
	J42	43E	43H	43K	44F	J44
Standstill torque M_0 [Nm]	4.10	5.65	5.65	5.60	7.10	7.10
Standstill current I_{orms} [A]	6.90	2.90	5.40	9.30	3.60	6.80
Maximum mechanical speed N_{max} [min ⁻¹]	9000					
Maximum nominal mains voltage U_N [V _{AC}]	480					
Peak current I_{0max} [A]	37.60	16.60	31	53.90	21.80	40
Peak torque M_{0max} [Nm]	18.89	29.33	29.25	29.25	39.10	37.80
Torque constant K_{Trms} [Nm/A]	0.59	1.94	1.04	0.60	1.97	1.04
Voltage constant K_{Erms} [mVmin]	41	131	73	42	137	70
Winding resistance Ph-Ph R_{20} [Ω]	1.40	8.90	2.40	0.83	7.2	1.5
Winding inductance Ph-Ph (measured at 1 kHz) L [mH]	6.30	42	11.70	3.90	22.4	8
Power supply $U_N = 115$ V						
Nominal speed N_n [min ⁻¹]	2200	500	1200	2200	500	1200
Nominal torque M_n [Nm]	3.90	5.58	5.50	5.27	7.00	6.8
Nominal output P_n [kW]	0.90	0.29	0.69	1.21	0.367	0.855
Power supply $U_N = 230$ V						
Nominal speed N_n [min ⁻¹]	5000	1200	2700	5000	1200	2700
Nominal torque M_n [Nm]	3.70	5.50	5.30	4.90	6.8	6.4
Nominal output P_n [kW]	1.94	0.70	1.50	2.57	0.855	1.81
Power supply $U_N = 400$ V						
Nominal speed N_n [min ⁻¹]	8000	2500	5000	8000	2500	5000
Nominal torque M_n [Nm]	3.10	5.30	4.90	4.10	6.50	6.00
Nominal output P_n [kW]	2.60	1.39	2.57	3.43	1.70	3.14
Nominal current I_n [A]	5.20	2.70	4.75	6.90	3.30	5.90
Power supply $U_N = 480$ V						
Nominal speed N_n [min ⁻¹]	8000	2800	5700	8000	2800	5700
Nominal torque M_n [Nm]	3.10	5.30	4.88	4.10	6.40	5.70
Nominal output P_n [kW]	2.60	1.55	2.91	3.43	1.88	3.40
Connection technology	M23-Speedtec					
<i>Reference flange aluminum 230 mm x 130 mm x 10 mm</i>						

Technical data

Mechanical data	AM8041	AM8541	AM8042	AM8542	AM8043	AM8543	AM8044
Rotor moment of inertia J [kgcm ²]	1.09	4.62	1.98	5.51	2.87	6.41	3.76
Rotor moment of inertia with brake J [kgcm ²]	1.73	5.27	2.63	6.17	3.52	7.06	4.42
Number of poles	8						
Static friction torque M _R [Nm]	0.02	0.02	0.02	0.02	0.03	0.03	0.04
Thermal time constant t _{TH} [min]	30	30	33	33	36	36	38
Weight [kg]	2.80	3.80	3.80	4.90	4.90	6	5.90
Weight with brake [kg]	3.60	4.50	4.70	5.70	5.80	6.90	6.80
Flange	IEC standard/DIN 42955						
Fit	j6						
Tolerance class	N						
Protection rating							
Standard housing version	IP65						
Standard shaft feedthrough version	IP54						
Shaft feedthrough with shaft sealing ring	IP65						
Paint finishes							
Properties	acrylic powder-coated						
Color	Anthracite gray; RAL 7016						
Optional holding brake [+]	AM804x			AM854x			
Holding torque at 120 °C M _{BR} [Nm]	9			9			
Supply voltage U _{BR} [V _{DC}]	24; +6 % to -10 %						
Electrical power P _{BR} [W]	18			18			
Current I _{on} [A]	0.54			0.54			
Release delay time t _{BRH} [ms]	40			40			
Application delay time t _{BRL} [ms]	20			20			

Dimensional drawing

- All figures in millimeters

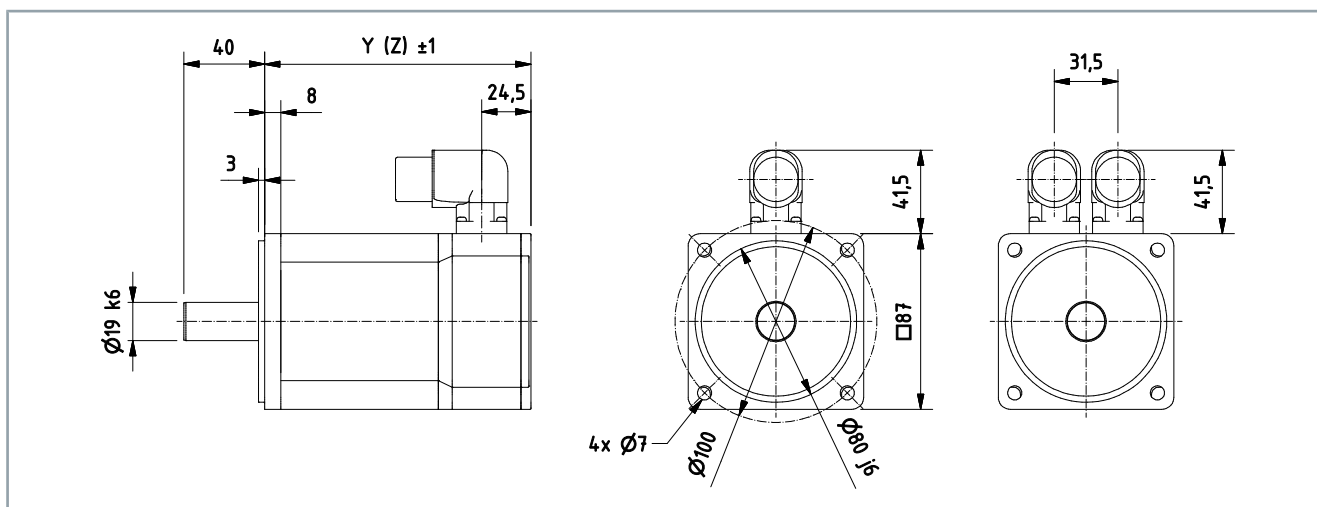

Motor	Y	Z - brake
AM8041	132	179.5
AM8042	162	209.5
AM8043	192	239.5
AM8044	222	269.5
AM8541	179.5	209.5
AM8542	209.5	239.5
AM8543	239.5	269.5

Feather key [+]

- Center bore according to DIN 332-D

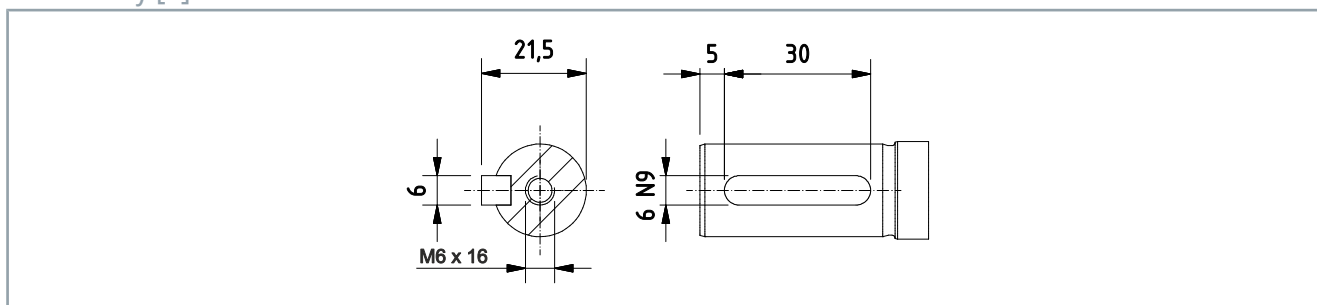

Force diagram



Beckhoff load/force calculator

The software represents axial and radial forces on the motor shaft. The following example shows an AM8042 without a holding brake.

- Download load/force calculator

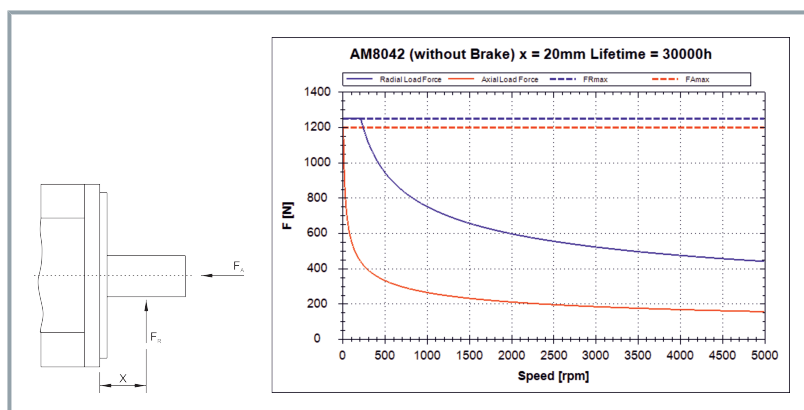

AM805x & AM855x

Electrical data	AM80xx and AM85xx					
	51E	51G	51K	52F	J52	52L
Standstill torque M_0 [Nm]	4.80	4.90	4.90	8.20	8.20	8.20
Standstill current I_{orms} [A]	2.70	4.75	8.50	3.30	6.30	11.30
Maximum mechanical speed N_{max} [min ⁻¹]	9000					
Maximum nominal mains voltage U_N [V _{AC}]	480					
Peak current I_{0max} [A]	12.10	20.90	37.70	17.90	33.60	60.70
Peak torque M_{0max} [Nm]	17.74	17.76	17.78	35.32	35.34	35.34
Torque constant K_{Trms} [Nm/A]	1.77	1.03	0.57	2.48	1.30	0.72
Voltage constant K_{Erms} [mV/min]	125	73	40	167	89	49
Winding resistance Ph-Ph R_{20} [Ω]	11.40	3.60	1.14	8.50	2.30	0.70
Winding inductance Ph-Ph (measured at 1 kHz) L [mH]	42.70	14.40	4.60	36.90	10.50	3.20
Power supply $U_N = 115 V$						
Nominal speed N_n [min ⁻¹]	500	1200	2300	400	1000	1900
Nominal torque M_n [Nm]	4.80	4.80	4.65	8	7.90	7.55
Nominal output P_n [kW]	0.25	0.60	1.12	0.34	0.83	1.50
Power supply $U_N = 230 V$						
Nominal speed N_n [min ⁻¹]	1400	2700	5000	1100	2200	4000
Nominal torque M_n [Nm]	4.70	4.65	4.40	7.80	7.50	6.90
Nominal output P_n [kW]	0.69	1.31	2.30	0.90	1.73	2.89
Power supply $U_N = 400 V$						
Nominal speed N_n [min ⁻¹]	2500	5000	8000	2000	4000	7300
Nominal torque M_n [Nm]	4.60	4.40	3.90	7.50	6.90	5.40
Nominal output P_n [kW]	1.20	2.30	3.27	1.57	2.89	4.13
Nominal current I_n [A]	2.55	4.20	6.70	3.10	5.20	7.50
Power supply $U_N = 480 V$						
Nominal speed N_n [min ⁻¹]	3000	5700	8000	2300	4500	7500
Nominal torque M_n [Nm]	4.50	4.30	3.90	7.40	6.70	5.40
Nominal output P_n [kW]	1.41	2.57	3.27	1.78	3.16	4.24
Connection technology	M23-Speedtec					
Reference flange aluminum 305 mm x 305 mm x 10 mm						

Electrical data	AM80xx and AM85xx				
	53G	53K	53N	J54	54M
Standstill torque M_0 [Nm]	11.40	11.40	11.40	13.80	13.80
Standstill current I_{0rms} [A]	4.70	8.80	15.60	6.50	12.40
Maximum mechanical speed N_{max} [min ⁻¹]	9000				
Maximum nominal mains voltage U_N [V _{AC}]	480				
Peak current I_{0max} [A]	26.90	50.90	89.70	39.90	75.30
Peak torque M_{0max} [Nm]	53.13	53.13	53.14	70.70	70.70
Torque constant K_{Trms} [Nm/A]	2.42	1.29	0.73	2.12	1.11
Voltage constant K_{Erms} [mVmin]	168	89	51	151	80
Winding resistance Ph-Ph R_{20} [Ω]	5.10	1.40	0.45	3.44	0.86
Winding inductance Ph-Ph (measured at 1 kHz) L [mH]	23.70	6.60	2.10	16	4
Power supply $U_N = 115$ V					
Nominal speed N_n [min ⁻¹]	400	1000	1900	500	1100
Nominal torque M_n [Nm]	11.10	10.80	10	12.80	11.70
Nominal output P_n [kW]	0.46	1.13	2	0.67	1.35
Power supply $U_N = 230$ V					
Nominal speed N_n [min ⁻¹]	1100	2200	4000	1000	2500
Nominal torque M_n [Nm]	10.70	9.90	8.35	11.80	9.60
Nominal output P_n [kW]	1.23	2.28	3.50	1.24	2.51
Power supply $U_N = 400$ V					
Nominal speed N_n [min ⁻¹]	2000	4000	7000	2000	4000
Nominal torque M_n [Nm]	10	8.35	2.70	10.30	7.30
Nominal output P_n [kW]	2.09	3.50	1.98	2.16	3.06
Nominal current I_n [A]	4.10	6.30	4.50	4.80	7.30
Power supply $U_N = 480$ V					
Nominal speed N_n [min ⁻¹]	2400	4500	7000	2200	4600
Nominal torque M_n [Nm]	9.70	7.85	2.70	10	6.40
Nominal output P_n [kW]	2.44	3.70	1.98	2.30	3.08
Connection technology	M23-Speedtec				
<i>Reference flange aluminum 305 mm x 305 mm x 10 mm</i>					

Technical data

Mechanical data	AM8051	AM8551	AM8052	AM8552	AM8053	AM8553	AM8054
Rotor moment of inertia J [kgcm ²]	2.25	8.75	4.09	10.60	5.93	12.40	7.90
Rotor moment of inertia with brake J [kgcm ²]	2.91	9.41	4.75	11.30	7.04	13.51	9.66
Number of poles	8						
Static friction torque M _R [Nm]	0.02	0.02	0.03	0.03	0.05	0.05	0.06
Thermal time constant t _{TH} [min]	31	31	38	38	40	40	42
Weight [kg]	4.10	5.50	5.70	7.10	7.40	8.80	9.10
Weight with brake [kg]	4.90	6.30	6.60	7.90	8.40	9.80	10.10
Flange	IEC standard/DIN 42955						
Fit	j6						
Tolerance class	N						
Protection rating							
Standard housing version	IP65						
Standard shaft feedthrough version	IP54						
Shaft feedthrough with shaft sealing ring	IP65						
Paint finishes							
Properties	acrylic powder-coated						
Color	Anthracite gray; RAL 7016						
Optional holding brake [+]	AM8051	AM8551	AM8052	AM8552	AM8053	AM8553	AM8054
Holding torque at 120 °C M _{BR} [Nm]	9	9	9	9	13	13	20
Supply voltage U _{BR} [V _{DC}]	24; +6 % to -10 %						
Electrical power P _{BR} [W]	18	18	18	18	17	17	24
Current I _{on} [A]	0.54	0.54	0.54	0.54	0.51	0.51	1
Release delay time t _{BRH} [ms]	40	40	40	40	45	45	110
Application delay time t _{BRL} [ms]	20	20	20	20	20	20	40

Dimensional drawing

- All figures in millimeters

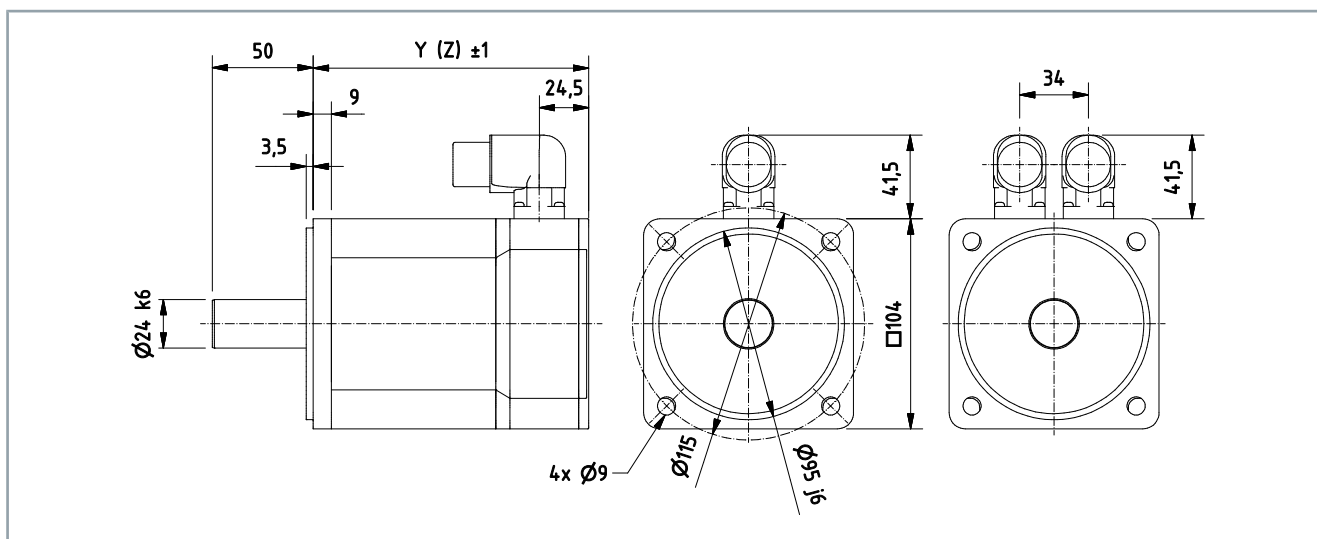

Motor	Y	Z-brake
AM8051	136.5	183.5
AM8052	169.5	216.5
AM8053	202.5	251.5
AM8054	251.5	284.5
AM8551	183.5	216.5
AM8552	216.5	251.5
AM8553	251.5	284.5

Feather key [+]

- Center bore according to DIN 332-D

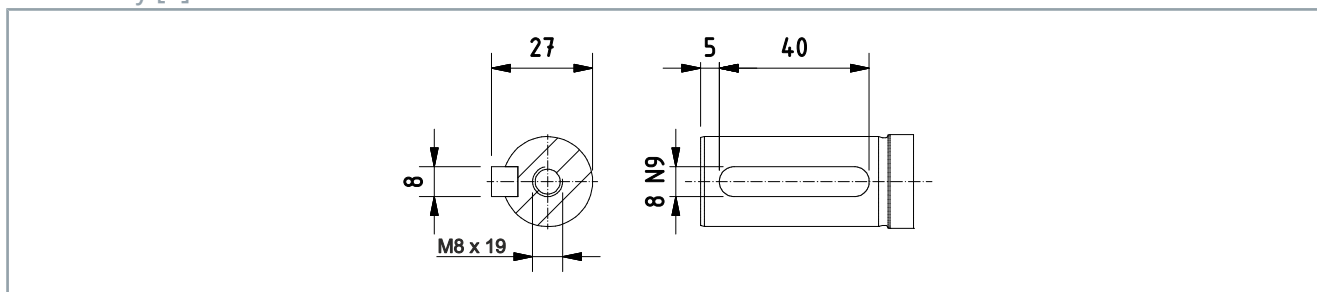

Dimensional drawing

- Flange of the AM8x5x-9000 compatible with AM3x5x
- All figures in millimeters

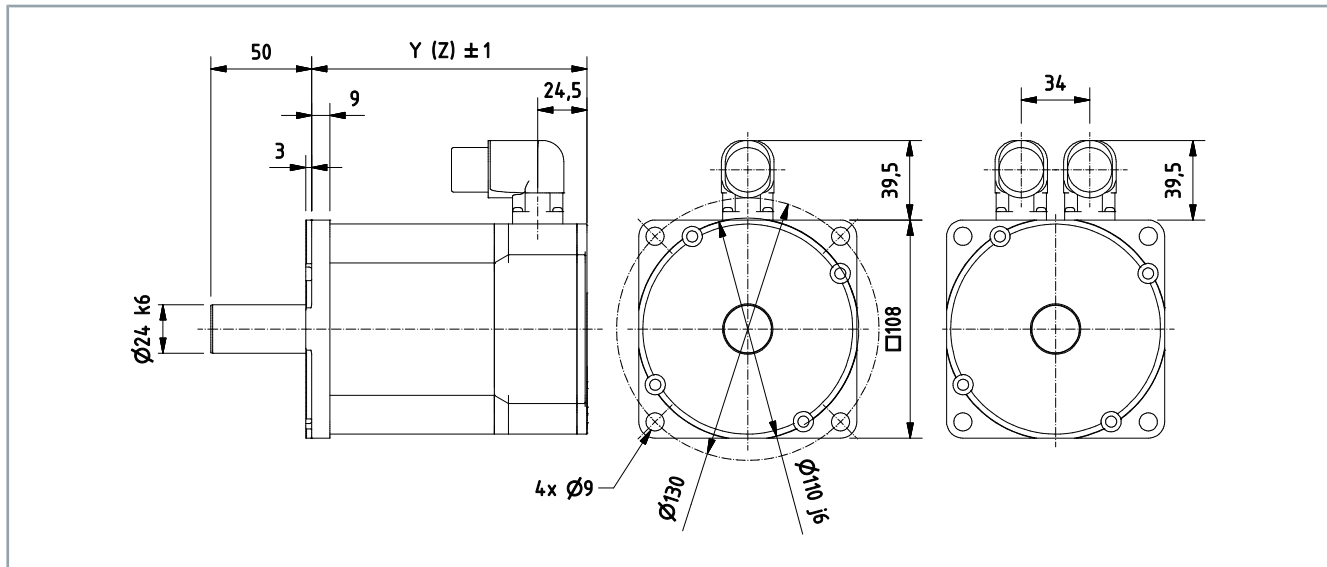

Motor	Y	Z-brake
AM8051-xxxx-9000	136.5	183.5
AM8052-xxxx-9000	169.5	216.5
AM8053-xxxx-9000	202.5	251.5
AM8054-xxxx-9000	251.5	284.5
AM8551-xxxx-9000	183.5	216.5
AM8552-xxxx-9000	216.5	251.5
AM8553-xxxx-9000	251.5	284.5

Feather key [+]

- Center bore according to DIN 332-D

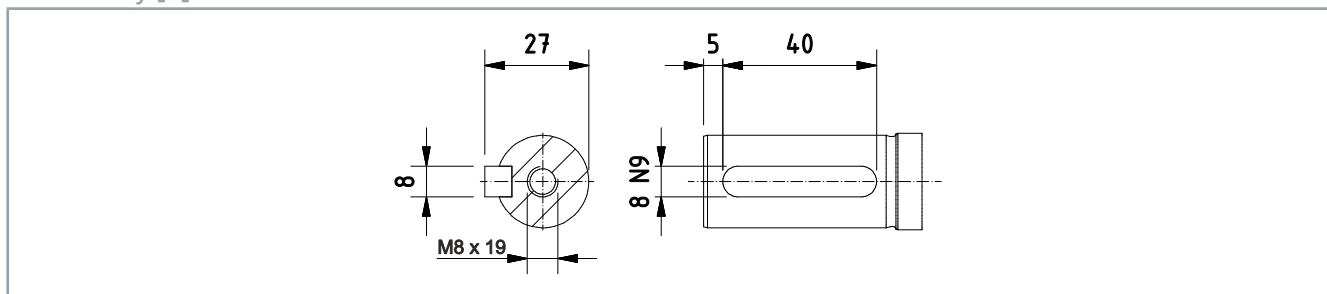

Force diagram



Beckhoff load/force calculator

The software represents axial and radial forces on the motor shaft. The following example shows an AM8052 without a holding brake.

- [Download load/force calculator](#)

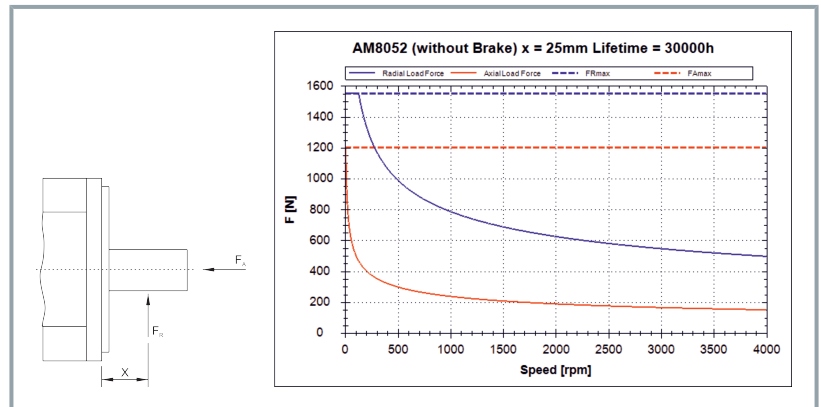

AM805x & AM855x with fan cover [+]

Electrical data	AM80xx and AM85xx					
	51F	J51	51L	52G	52K	52N
Standstill torque M_0 [Nm]	6.20	6.30	6.30	10.70	10.70	9.60
Standstill current I_{orms} [A]	3.50	5.80	11.10	4.30	8.50	13.60
Maximum mechanical speed N_{max} [min ⁻¹]	9000					
Maximum nominal mains voltage U_N [V _{AC}]	480					
Peak current I_{0max} [A]	12.10	20.90	37.70	17.90	33.60	60.70
Peak torque M_{0max} [Nm]	17.74	17.76	17.78	35.32	35.34	35.34
Torque constant K_{Trms} [Nm/A]	1.77	1.09	0.57	2.48	1.30	0.72
Voltage constant K_{Erms} [mV/min]	125	73	40	167	89	49
Winding resistance Ph-Ph R_{20} [Ω]	11.40	3.60	1.14	8.50	2.30	0.70
Winding inductance Ph-Ph (measured at 1 kHz) L [mH]	42.70	14.40	4.60	36.90	10.50	3.20
Power supply $U_N = 115 V$						
Nominal speed N_n [min ⁻¹]	500	1100	2300	400	900	1900
Nominal torque M_n [Nm]	6.10	6.20	5.90	10.50	10.30	9.50
Nominal output P_n [kW]	0.32	0.71	1.42	0.44	0.97	1.90
Power supply $U_N = 230 V$						
Nominal speed N_n [min ⁻¹]	1400	2600	4900	1000	2100	4000
Nominal torque M_n [Nm]	6.00	5.80	5.30	10.30	9.60	8.10
Nominal output P_n [kW]	0.88	1.58	2.72	1.08	2.11	3.40
Power supply $U_N = 400 V$						
Nominal speed N_n [min ⁻¹]	2500	4750	8000	2000	4000	6000
Nominal torque M_n [Nm]	5.80	5.50	3.60	9.70	9.10	5.40
Nominal output P_n [kW]	1.52	2.74	3.02	2.03	3.77	4.08
Nominal current I_n [A]	3.20	5.20	6.30	4.00	7.10	9.00
Power supply $U_N = 480 V$						
Nominal speed N_n [min ⁻¹]	3000	5000	8000	2300	4500	7000
Nominal torque M_n [Nm]	5.70	5.40	3.60	9.20	8.80	4.50
Nominal output P_n [kW]	1.79	3.22	3.01	2.21	4.14	4.24
Connection technology	M23-Speedtec					
Reference flange aluminum 305 mm x 305 mm x 10 mm						

Electrical data	AM80xx and AM85xx				
	J53	53L	53P	54K	54N
Standstill torque M_0 [Nm]	15.40	15.40	13.30	17.20	17.20
Standstill current I_{0rms} [A]	6.40	11.90	18.60	8.10	15.5
Maximum mechanical speed N_{max} [min ⁻¹]	9000				
Maximum nominal mains voltage U_N [V _{AC}]	480				
Peak current I_{0max} [A]	26.90	50.90	89.70	39.90	75.30
Peak torque M_{0max} [Nm]	53.13	53.13	53.14	70.70	70.70
Torque constant K_{Trms} [Nm/A]	2.42	1.29	0.73	2.12	1.11
Voltage constant K_{Erms} [mVmin]	168	89	51	151	80
Winding resistance Ph-Ph R_{20} [Ω]	5.10	1.40	0.45	3.44	0.86
Winding inductance Ph-Ph (measured at 1 kHz) L [mH]	23.70	6.60	2.10	16	4
Power supply $U_N = 115$ V					
Nominal speed N_n [min ⁻¹]	400	1000	1900	500	1100
Nominal torque M_n [Nm]	15.30	15.10	12.30	16.80	15.50
Nominal output P_n [kW]	0.65	1.58	2.45	0.88	1.79
Power supply $U_N = 230$ V					
Nominal speed N_n [min ⁻¹]	1000	2200	4000	1000	2500
Nominal torque M_n [Nm]	15.10	14.80	8.40	16.40	13.30
Nominal output P_n [kW]	1.58	3.40	3.52	1.72	3.48
Power supply $U_N = 400$ V					
Nominal speed N_n [min ⁻¹]	2000	4000	5000	2000	4000
Nominal torque M_n [Nm]	14.90	12.90	7.10	15.5	10.95
Nominal output P_n [kW]	3.12	5.41	3.72	3.25	4.59
Nominal current I_n [A]	6.10	10	6	7.30	9.90
Power supply $U_N = 480$ V					
Nominal speed N_n [min ⁻¹]	2300	4500	7000	2200	4600
Nominal torque M_n [Nm]	14.70	12.10	4.10	15.30	10
Nominal output P_n [kW]	3.54	5.84	3	3.52	4.82
Connection technology	M23-Speedtec				
<i>Reference flange aluminum 305 mm x 305 mm x 10 mm</i>					

Technical data

Mechanical data	AM8051	AM8551	AM8052	AM8552	AM8053	AM8553	AM8054
Rotor moment of inertia J [kgcm ²]	2.24	8.75	4.08	10.60	5.92	12.50	7.90
Rotor moment of inertia with brake J [kgcm ²]	2.90	9.41	4.74	11.20	7.04	13.51	9.66
Number of poles	8						
Static friction torque M _R [Nm]	0.02	0.02	0.03	0.03	0.05	0.05	0.06
Thermal time constant t _{TH} [min]	31	31	38	38	40	40	42
Weight [kg]	5.20	6.60	6.80	8.10	8.50	9.90	10.20
Weight with brake [kg]	6	7.40	7.70	9	9.50	10.90	11.20
Flange	IEC standard/DIN 42955						
Fit	j6						
Tolerance class	N						
Protection rating							
Standard housing version	Standard: IP20 Optional: IP65						
Standard shaft feedthrough version	IP54						
Shaft feedthrough with shaft sealing ring	IP65						
Paint finishes							
Properties	acrylic powder-coated						
Color	Anthracite gray; RAL 7016						
Optional holding brake [+]	AM8051	AM8551	AM8052	AM8552	AM8053	AM8553	AM8054
Holding torque at 120 °C M _{BR} [Nm]	9	9	9	9	13	13	20
Supply voltage U _{BR} [V _{DC}]	24; +6 % to -10 %						
Electrical power P _{BR} [W]	18	18	18	18	17	17	24
Current I _{on} [A]	0.54	0.54	0.54	0.54	0.51	0.51	1.0
Release delay time t _{BRH} [ms]	40	40	40	40	45	45	110
Application delay time t _{BRL} [ms]	20	20	20	20	20	20	40

Dimensional drawing

- Illustration with fan cover [+]
- All figures in millimeters

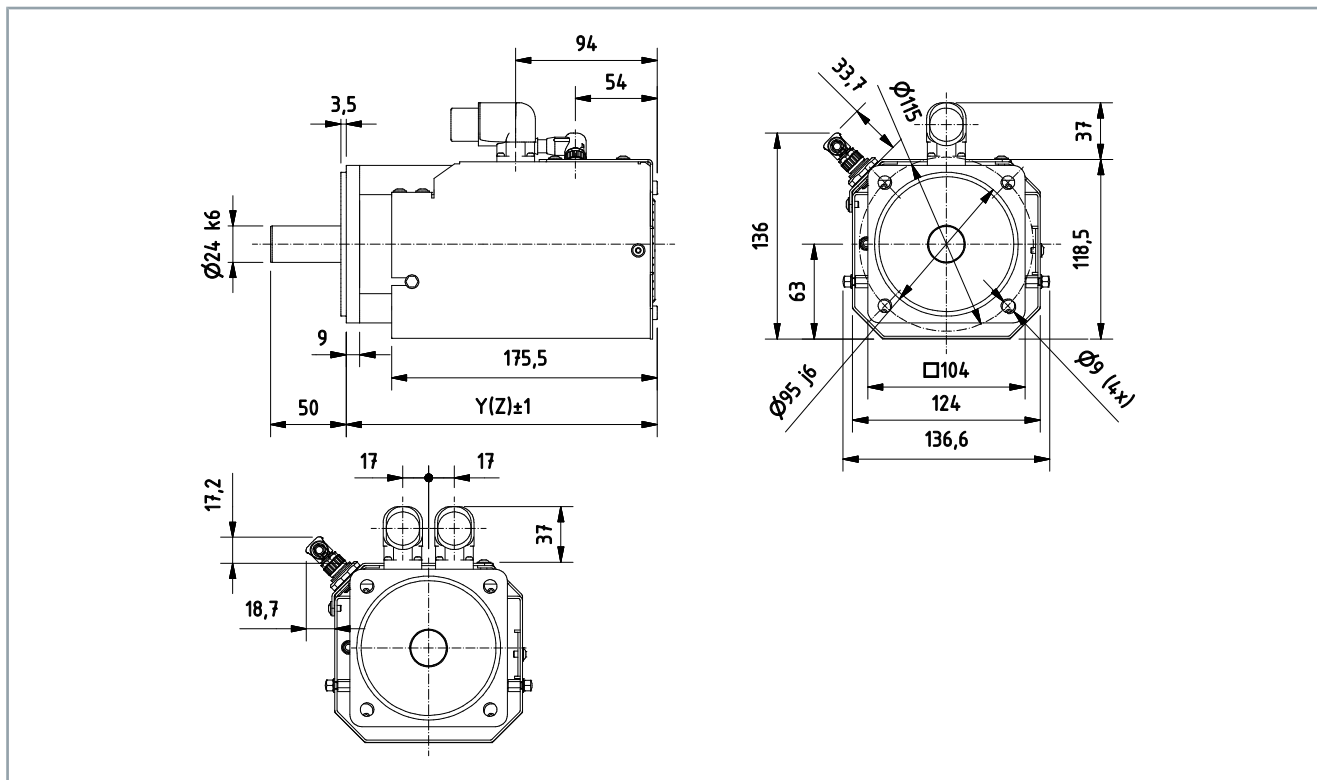

Motor	Y/Z
AM8051-xxxA-xxx0 and AM8051-xxxC-xxx0	205.5
AM8051-xxxB-xxx0 and AM8051-xxxD-xxx0	252.5
AM8052-xxxA-xxx0 and AM8052-xxxC-xxx0	238.5
AM8052-xxxB-xxx0 and AM8052-xxxD-xxx0	285.5
AM8053-xxxA-xxx0 and AM8053-xxxC-xxx0	271.5
AM8053-xxxB-xxx0 and AM8053-xxxD-xxx0	320.5
AM8054-xxxA-xxx0 and AM8054-xxxC-xxx0	320.5
AM8054-xxxB-xxx0 and AM8054-xxxD-xxx0	369
AM8551-xxxA-xxx0 and AM8551-xxxC-xxx0	252.5
AM8551-xxxB-xxx0 and AM8551-xxxD-xxx0	285.5
AM8552-xxxA-xxx0 and AM8552-xxxC-xxx0	285.5
AM8552-xxxB-xxx0 and AM8552-xxxD-xxx0	320.5
AM8553-xxxA-xxx0 and AM8553-xxxC-xxx0	320.5
AM8553-xxxB-xxx0 and AM8553-xxxD-xxx0	353.5

Feather key [+]

- Center bore according to DIN 332-D

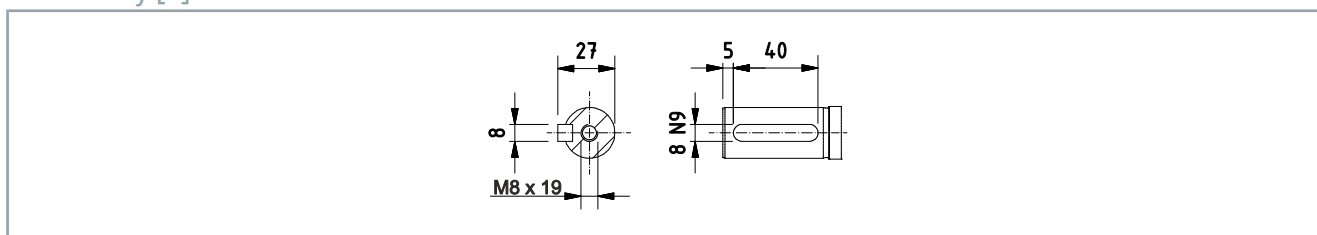

Dimensional drawing

- Flange of the AM8x5x-9000 compatible with AM3x5x
- Illustration with fan cover [+]
- All figures in millimeters

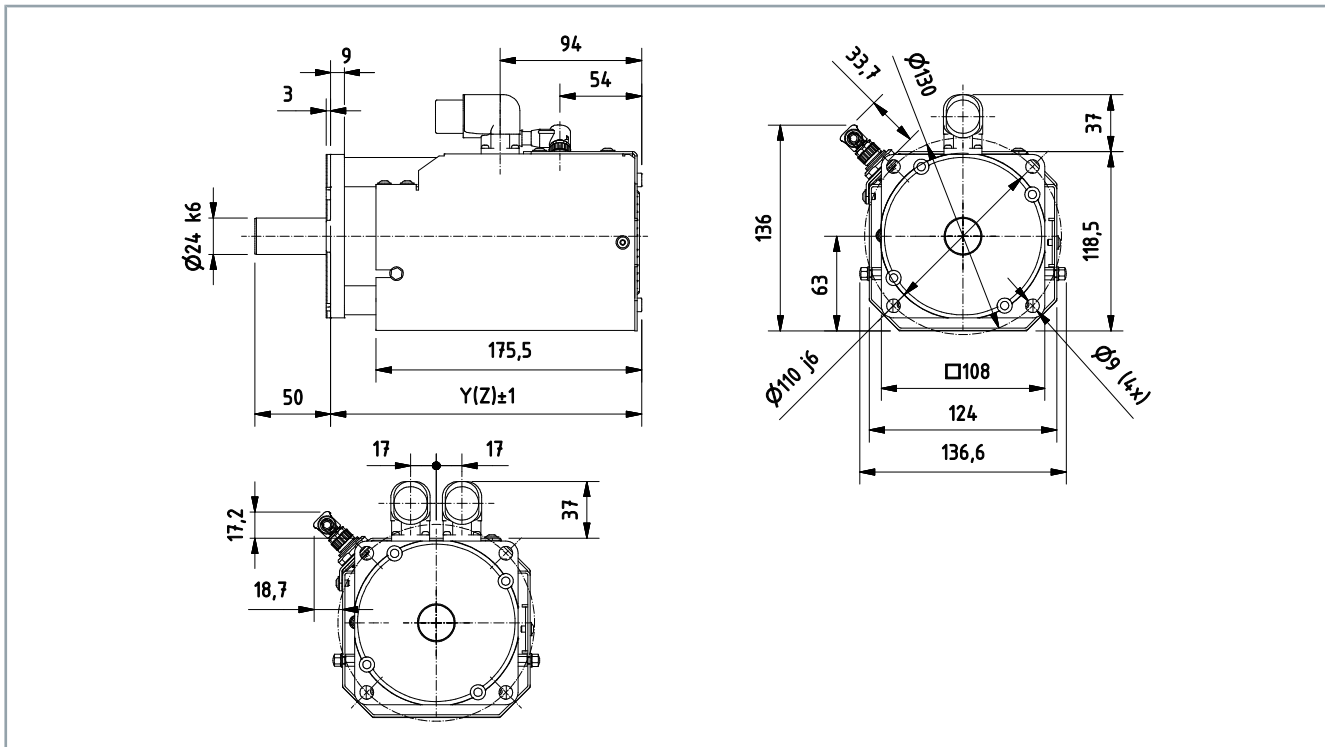

Motor	Y/Z
AM8051-xxxA-9000 and AM8051-xxxC-9000	205.5
AM8051-xxxB-9000 and AM8051-xxxD-9000	252.5
AM8052-xxxA-9000 and AM8052-xxxC-9000	238.5
AM8052-xxxB-9000 and AM8052-xxxD-9000	285.5
AM8053-xxxA-9000 and AM8053-xxxC-9000	271.5
AM8053-xxxB-9000 and AM8053-xxxD-9000	320.5
AM8054-xxxA-9000 and AM8054-xxxC-9000	320.5
AM8054-xxxB-9000 and AM8054-xxxD-9000	369
AM8551-xxxA-9000 and AM8551-xxxC-9000	252.5
AM8551-xxxB-9000 and AM8551-xxxD-9000	285.5
AM8552-xxxA-9000 and AM8552-xxxC-9000	285.5
AM8552-xxxB-9000 and AM8552-xxxD-9000	320.5
AM8553-xxxA-9000 and AM8553-xxxC-9000	320.5
AM8553-xxxB-9000 and AM8553-xxxD-9000	353.5

Feather key [+]

- Center bore according to DIN 332-D

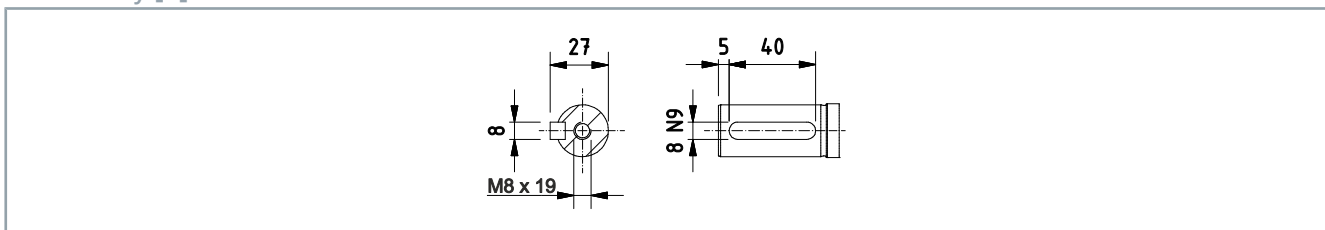

AM806x & AM856x

Electrical data	AM80xx and AM85xx					
	61G	J61	61M	J62	62L	62P
Standstill torque M_0 [Nm]	12.80	12.80	12.80	21.10	21.10	21.10
Standstill current I_{orms} [A]	4	7.80	13.10	6.20	12.40	20.30
Maximum mechanical speed N_{max} [min ⁻¹]	6000					
Maximum nominal mains voltage U_N [V _{AC}]	480					
Peak current I_{0max} [A]	13.90	27	45.20	27	54	88.40
Peak torque M_{0max} [Nm]	37.10	37.08	37.07	74.16	74.16	74.17
Torque constant K_{Trms} [Nm/A]	3.20	1.64	0.97	3.40	1.70	1.03
Voltage constant K_{Erms} [mVmin]	223	115	69	234	117	71
Winding resistance Ph-Ph R_{20} [Ω]	7	1.85	0.66	2.95	0.75	0.28
Winding inductance Ph-Ph (measured at 1 kHz) L [mH]	53.70	14.20	5.10	27	6.80	2.50
Power supply $U_N = 115$ V						
Nominal speed N_n [min ⁻¹]	300	750	1300	300	800	1400
Nominal torque M_n [Nm]	12.60	12.40	12.20	20.70	20.10	18.60
Nominal output P_n [kW]	0.40	0.97	1.66	0.65	1.68	2.73
Power supply $U_N = 230$ V						
Nominal speed N_n [min ⁻¹]	800	1600	2800	800	1700	2800
Nominal torque M_n [Nm]	12.40	12.00	11.10	20.10	18.20	15.30
Nominal output P_n [kW]	1.04	2.01	3.25	1.68	3.24	4.49
Power supply $U_N = 400$ V						
Nominal speed N_n [min ⁻¹]	1500	3000	5000	1500	3000	5000
Nominal torque M_n [Nm]	12.10	11.00	9.00	18.50	15.20	6.50
Nominal output P_n [kW]	1.90	3.46	4.71	2.91	4.78	3.40
Nominal current I_n [A]	3.90	6.80	9.10	5.60	9.40	6.60
Power supply $U_N = 480$ V						
Nominal speed N_n [min ⁻¹]	1700	3400	5000	1700	3400	5000
Nominal torque M_n [Nm]	12	10.40	9	18.20	13.90	6.50
Nominal output P_n [kW]	2.14	3.70	4.71	3.24	4.95	3.40
Connection technology	M23-Speedtec					
<i>Reference flange aluminum 380 mm x 170 mm x 10 mm</i>						

Technical data

Electrical data	AM80xx and AM85xx					
	63K	63N	63R	64L	64Q	64T
Standstill torque M_0 [Nm]	29	29	29	35.30	35.30	35
Standstill current I_{0rms} [A]	8.70	17.20	29.50	10.80	22.20	35
Maximum mechanical speed N_{max} [min ⁻¹]	6000					
Maximum nominal mains voltage U_N [V _{AC}]	480					
Peak current I_{0max} [A]	38.90	80.90	130	52.50	108	177
Peak torque M_{0max} [Nm]	110.90	110.80	111.10	148	148	148
Torque constant K_{Trms} [Nm/A]	3.33	1.68	0.98	3.27	1.59	1
Voltage constant K_{Erms} [mV/min]	240	116	72	230	112	69
Winding resistance Ph-Ph R_{20} [Ω]	1.95	0.45	0.18	1.47	0.35	0.135
Winding inductance Ph-Ph (measured at 1 kHz) L [mH]	18	4.20	1.60	14.40	3.40	1.26
Power supply $U_N = 115 V$						
Nominal speed N_n [min-1]	300	800	1400	400	800	1000
Nominal torque M_n [Nm]	28.20	25.90	22.80	33.3	31	30
Nominal output P_n [kW]	0.89	2.17	3.34	1.39	2.60	3.14
Power supply $U_N = 230 V$						
Nominal speed N_n [min-1]	800	1700	3000	800	1700	2000
Nominal torque M_n [Nm]	25.90	21.10	13.20	31.40	27.60	24
Nominal output P_n [kW]	2.17	3.76	4.15	2.63	4.91	5.03
Power supply $U_N = 400 V$						
Nominal speed N_n [min-1]	1500	3000	4000	1500	3000	4000
Nominal torque M_n [Nm]	22.30	13.20	6.10	28	20.90	10
Nominal output P_n [kW]	3.50	4.15	2.56	4.40	6.57	4.19
Nominal current I_n [A]	6.70	8.10	6	8.50	14.10	11
Power supply $U_N = 480 V$						
Nominal speed N_n [min-1]	1700	3400	4000	1700	3200	4000
Nominal torque M_n [Nm]	21.10	11	6.10	27.20	19.90	10
Nominal output P_n [kW]	3.76	3.92	2.56	4.84	6.67	4.19
Connection technology	M23-Speedtec		M40-Speedtec	M23-Speedtec	M40-Speedtec	
<i>Reference flange aluminum 380 mm x 170 mm x 10 mm</i>						

Mechanical data	AM8061	AM8561	AM8062	AM8562	AM8063	AM8563	AM8064
Rotor moment of inertia J [kgcm ²]	11.10	48.20	20	57.10	29	66.10	38.60
Rotor moment of inertia with brake J [kgcm ²]	13.40	50.60	22.30	59.60	34.90	72	43.90
Number of poles	10						
Static friction torque M _R [Nm]	0.04	0.04	0.10	0.10	0.15	0.15	0.20
Thermal time constant t _{TH} [min]	35	35	38	38	41	41	44
Weight [kg]	9.80	13.20	13.60	17.00	17.40	20.90	21.20
Weight with brake [kg]	11.60	14.80	15.40	18.70	20.10	23.6	26.6
Flange	IEC standard/DIN 42955						
Fit	j6						
Tolerance class	N						
Protection rating							
Standard housing version	IP65						
Standard shaft feedthrough version	IP54						
Shaft feedthrough with shaft sealing ring	IP65						
Paint finishes							
Properties	acrylic powder-coated						
Color	Anthracite gray; RAL 7016						
Optional holding brake [+]	AM8061	AM8561	AM8062	AM8562	AM8063		
Holding torque at 120 °C M _{BR} [Nm]	20	20	20	20	36		
Supply voltage U _{BR} [V _{DC}]	24; +6 % to -10 %						
Electrical power P _{BR} [W]	24	24	24	24	26		
Current I _{on} [A]	0.72	0.72	0.72	0.72	0.79		
Release delay time t _{BRH} [ms]	60	60	60	60	120		
Application delay time t _{BRL} [ms]	40	40	40	40	45		

Dimensional drawing

- All figures in millimeters

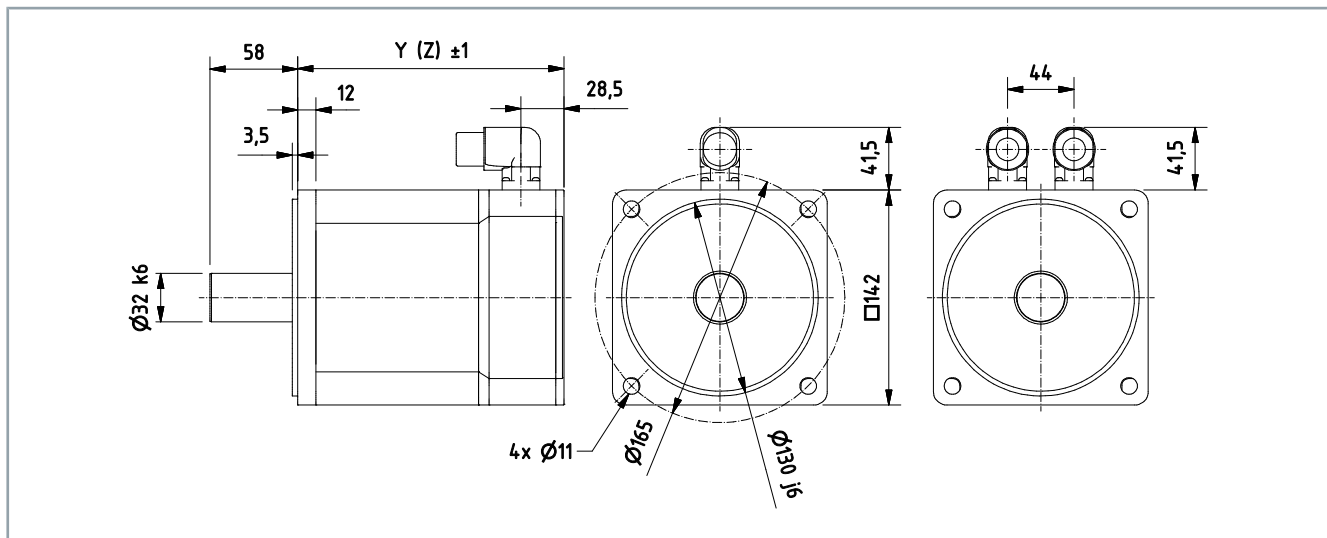

Motor	Y	Z - brake
AM8061	176	228
AM8062	216	268
AM8063	256	315
AM8064	296	355
AM8561	228	268
AM8562	268	315
AM8563	315	355

Feather key [+]

- Center bore according to DIN 332-D

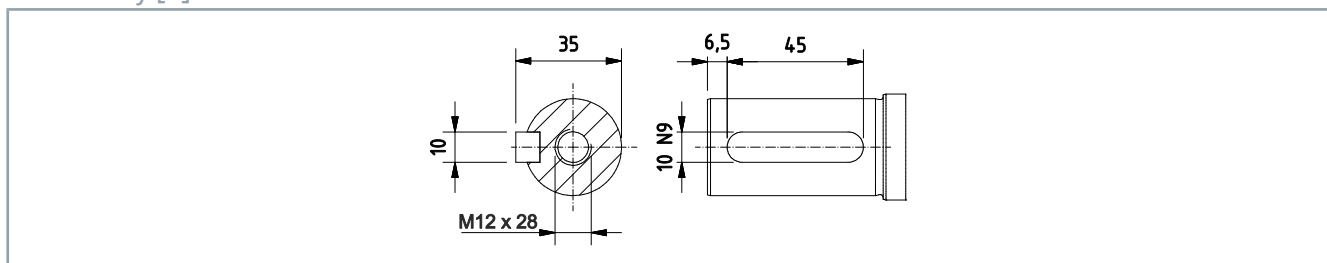

Dimensional drawing

- Illustration with R-winding
- All figures in millimeters

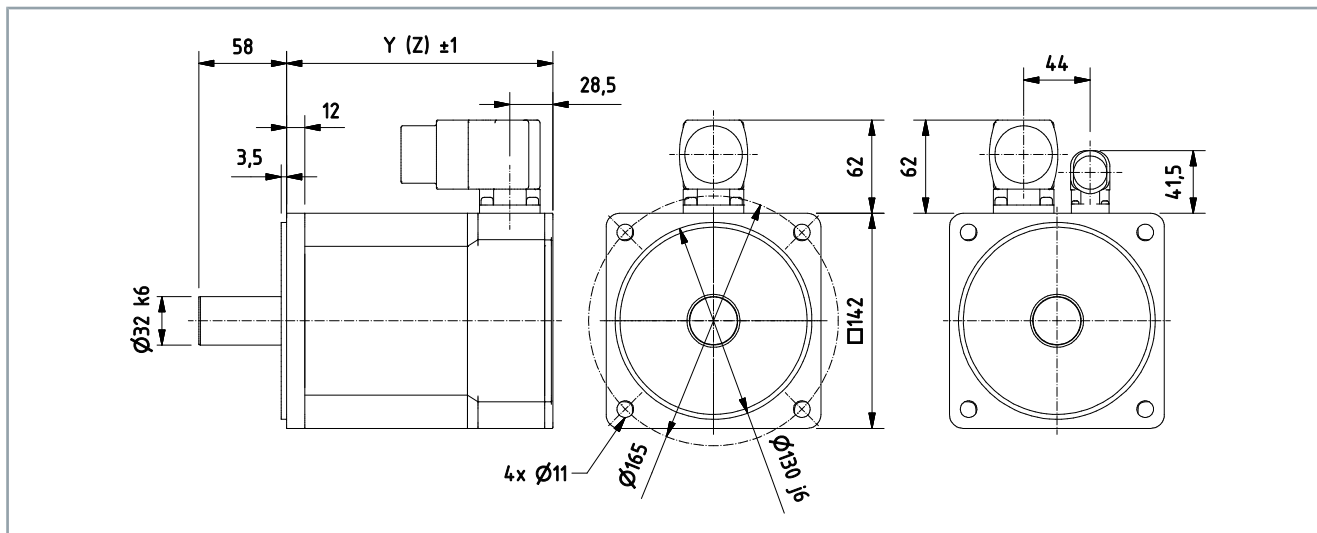

Motor	Y	Z – brake
AM8063-xRxx	256	315
AM8563-xRxx	315	355

Feather key [+]

- Center bore according to DIN 332-D

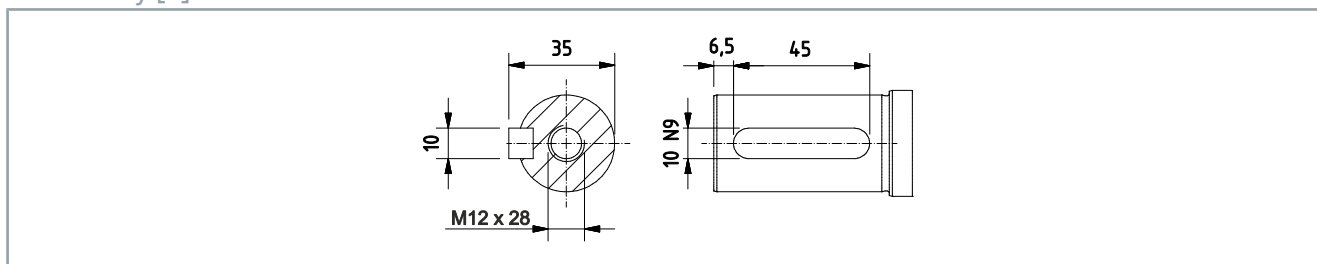

Force diagram



Beckhoff load/force calculator

The software represents axial and radial forces on the motor shaft. The following example shows an AM8062 without a holding brake.

- [Download load/force calculator](#)

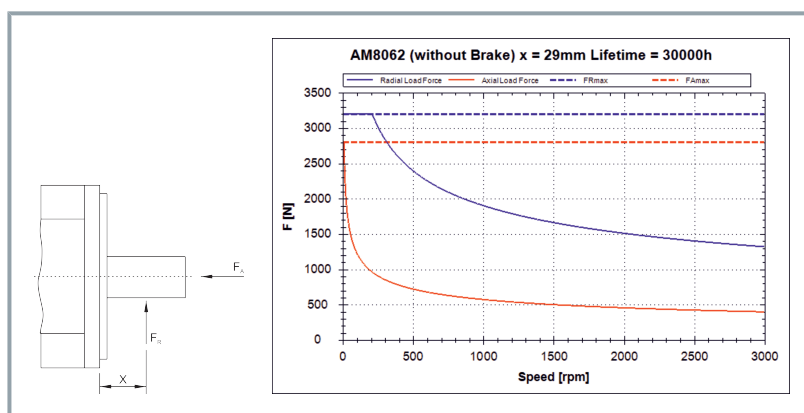

AM806x & AM856x with fan cover [+]

Electrical data	AM80xx and AM85xx					
	61H	61L	61N	62K	62N	62R
Standstill torque M_0 [Nm]	17.10	17.10	15.50	29.90	29.90	28.10
Standstill current I_{0rms} [A]	5.20	10.10	15.80	8.70	17.40	28.70
Maximum mechanical speed N_{max} [min ⁻¹]	6000					
Maximum nominal mains voltage U_N [V _{AC}]	480					
Peak current I_{0max} [A]	13.90	27	45.20	27	54	88.40
Peak torque M_{0max} [Nm]	37.10	37.08	37.07	74.16	74.16	74.17
Torque constant K_{Trms} [Nm/A]	3.20	1.64	0.97	3.40	1.70	1.03
Voltage constant K_{Erms} [mVmin]	223	115	69	234	117	71
Winding resistance Ph-Ph R_{20} [Ω]	7	1.85	0.66	2.95	0.75	0.28
Winding inductance Ph-Ph (measured at 1 kHz) L [mH]	53.70	14.20	5.10	27	6.80	2.50
Power supply $U_N = 115$ V						
Nominal speed N_n [min-1]	300	750	1300	300	800	1400
Nominal torque M_n [Nm]	17	16.80	14.40	29	28	24
Nominal output P_n [kW]	0.50	1	2	0.90	2.30	3.50
Power supply $U_N = 230$ V						
Nominal speed N_n [min-1]	700	1600	2800	750	1700	2800
Nominal torque M_n [Nm]	16.80	16	12.70	28.20	25.80	19.90
Nominal output P_n [kW]	1.40	2.70	3.70	2.40	4.60	5.80
Power supply $U_N = 400$ V						
Nominal speed N_n [min-1]	1400	3000	5000	1400	3000	5000
Nominal torque M_n [Nm]	16.10	14.70	10.70	26.40	22.20	13.40
Nominal output P_n [kW]	2.36	4.60	5.60	3.87	7	7
Nominal current I_n [A]	4.90	9	11.20	7.70	13.40	13.60
Power supply $U_N = 480$ V						
Nominal speed N_n [min-1]	1500	3400	5500	1600	3400	5500
Nominal torque M_n [Nm]	16.00	14.30	10.70	25.80	21.10	11.80
Nominal output P_n [kW]	2.50	5.10	6.20	4.30	7.50	6.80
Connection technology	M23-Speedtec					M40-speedtec
<i>Reference flange aluminum 380 mm x 170 mm x 10 mm</i>						

Electrical data	AM80xx and AM85xx					
	63L	63Q	63T	64N	64R	64T
Standstill torque M_0 [Nm]	41.40	41.40	40.10	49.70	49.60	47
Standstill current I_{0rms} [A]	11.60	24	39.80	15.20	30.80	47
Maximum mechanical speed N_{max} [min ⁻¹]	6000					
Maximum nominal mains voltage U_N [V _{AC}]	480					
Peak current I_{0max} [A]	38.90	80.90	130	52.50	108	177
Peak torque M_{0max} [Nm]	110.90	110.90	110.80	148	148	148
Torque constant K_{Tms} [Nm/A]	3.33	1.68	0.98	3.27	1.61	1
Voltage constant K_{Ems} [mVmin]	240	116	72	230	112	69
Winding resistance Ph-Ph R_{20} [Ω]	1.95	0.45	0.18	1.47	0.35	0.135
Winding inductance Ph-Ph (measured at 1 kHz) L [mH]	18	4.20	1.60	14.40	3.40	1.26
Power supply $U_N = 115$ V						
Nominal speed N_n [min ⁻¹]	300	800	1400	400	800	1000
Nominal torque M_n [Nm]	40.40	38.20	32.50	48	46.80	41.50
Nominal output P_n [kW]	1.30	3.20	4.80	2.01	3.93	4.35
Power supply $U_N = 230$ V						
Nominal speed N_n [min ⁻¹]	750	1700	2900	800	1700	2000
Nominal torque M_n [Nm]	38.50	32.30	23.70	46.80	42.50	36
Nominal output P_n [kW]	3	5.80	7.20	3.92	7.57	7.54
Power supply $U_N = 400$ V						
Nominal speed N_n [min ⁻¹]	1400	3000	4000	1500	3000	4000
Nominal torque M_n [Nm]	33.90	25.50	15.10	43	36.50	25
Nominal output P_n [kW]	4.97	8	6.30	6.75	11.50	10.50
Nominal current I_n [A]	9.50	15.60	16.20	13.10	24.40	27.50
Power supply $U_N = 480$ V						
Nominal speed N_n [min ⁻¹]	1600	3400	5000	1700	3200	4000
Nominal torque M_n [Nm]	33	23.20	6.80	42.50	35	25
Nominal output P_n [kW]	5.50	8.30	3.60	7.57	11.70	10.50
Connection technology	M23-Speedtec	M40-speedtec		M23-Speedtec	M40-speedtec	terminal box
<i>Reference flange aluminum 380 mm x 170 mm x 10 mm</i>						

Technical data

Mechanical data	AM8061	AM8561	AM8062	AM8562	AM8063	AM8563	AM8064
Rotor moment of inertia J [kgcm ²]	11.10	48.20	20	57.10	29	66.10	38.60
Rotor moment of inertia with brake J [kgcm ²]	13.40	50.60	22.30	59.60	34.90	72	46.80
Number of poles	10						
Static friction torque M _R [Nm]	0.04	0.04	0.10	0.10	0.15	0.15	0.20
Thermal time constant t _{TH} [min]	35	35	38	38	41	41	44
Weight without brake [kg]	11.90	15.40	15.80	19.20	19.60	23.10	23.40
Weight with brake [kg]	13.50	17.00	17.60	20.90	22.30	25.8	26.6
Flange							
Fit	j6						
Tolerance class	N						
Standard housing version	Standard: IP20 Optional: IP65						
Standard shaft feedthrough version	IP54						
Shaft feedthrough with shaft sealing ring	IP65						
Properties	acrylic powder-coated						
Color	Anthracite gray; RAL 7016						
Optional holding brake [+]	AM8061	AM8561	AM8062	AM8562	AM8063		
Holding torque at 120 °C M _{BR} [Nm]	20	20	20	20	36		
Supply voltage U _{BR} [V _{DC}]	24; +6 % to -10 %						
Electrical power P _{BR} [W]	24	24	24	24	26		
Current I _{on} [A]	0.72	0.72	0.72	0.72	0.79		
Release delay time t _{BRH} [ms]	60	60	60	60	120		
Application delay time t _{BRL} [ms]	40	40	40	40	45		

Dimensional drawing

- Illustration with fan cover [+]
- All figures in millimeters

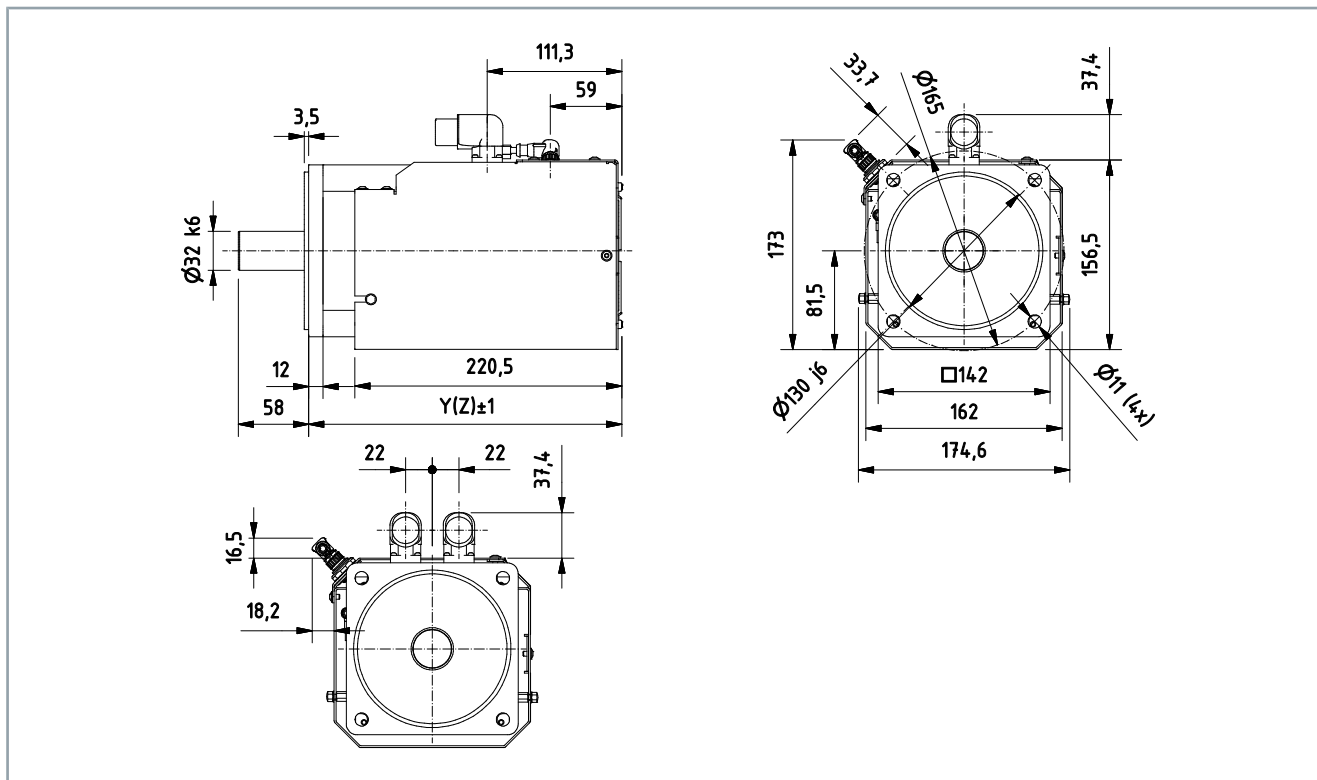

Motor	Y/Z
AM8061-xxxA-xxx0 and AM8061-xxxC-xxx0	259
AM8061-xxxB-xxx0 and AM8061-xxxD-xxx0	311
AM8561-xxxA-xxx0 and AM8561-xxxC-xxx0	311
AM8561-xxxB-xxx0 and AM8561-xxxD-xxx0	351

Feather key [+]

- Center bore according to DIN 332-D

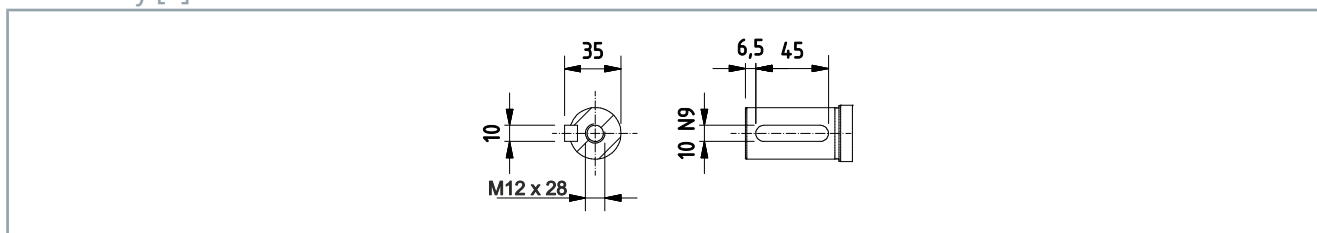

Dimensional drawing

- Illustration with fan cover [+] and K-N-L winding
- All figures in millimeters

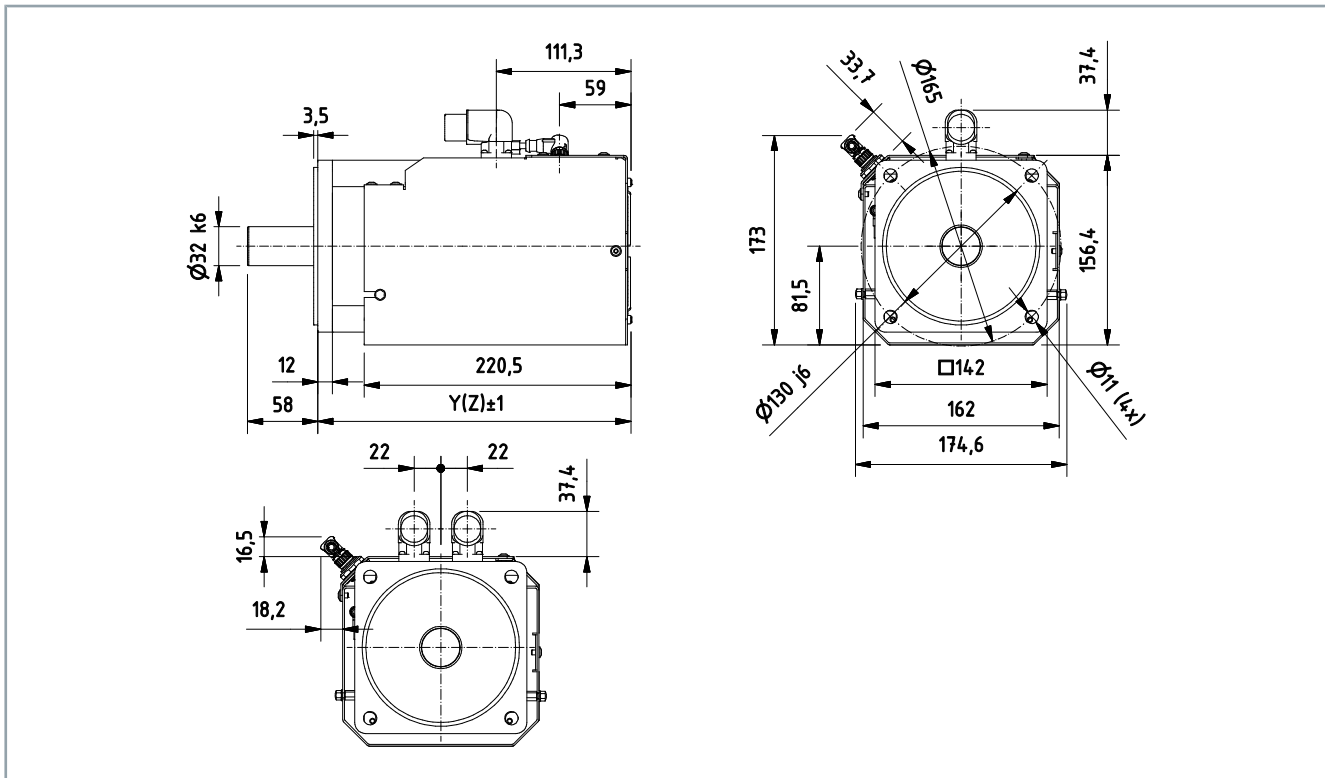

Motor	Y/Z
AM8062-xKxA-xxx0 and AM8062-xKxC-xxx0	299
AM8062-xKxB-xxx0 and AM8062-xKxD-xxx0	351
AM8062-xNxA-xxx0 and AM8062-xNxC-xxx0	299
AM8062-xNxB-xxx0 and AM8062-xNx D-xxx0	351
AM8063-xLxA-xxx0 and AM8063-xLxC-xxx0	339
AM8063-xLxB-xxx0 and AM8063-xLxD-xxx0	398
AM8064-xNxA-xxx0 and AM8064-xNxC-xxx0	398
AM8562-xKxA-xxx0 and AM8562-xKxC-xxx0	351
AM8562-xNxA-xxx0 and AM8562-xNxC-xxx0	351
AM8562-xKxB-xxx0 and AM8562-xKxD-xxx0	398
AM8562-xNxB-xxx0 and AM8562-xNx D-xxx0	398
AM8563-xLxA-xxx0 and AM8563-xLxC-xxx0	398

Feather key [+]

- Center bore according to DIN 332-D

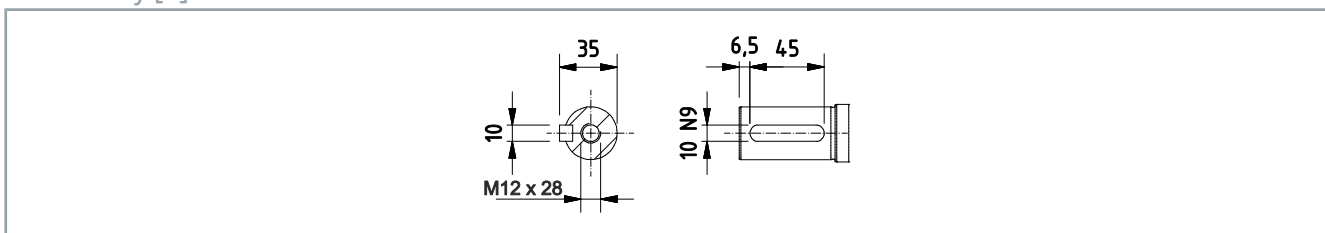

Dimensional drawing

- Illustration with fan cover [+] and R-Q-T winding
- All figures in millimeters

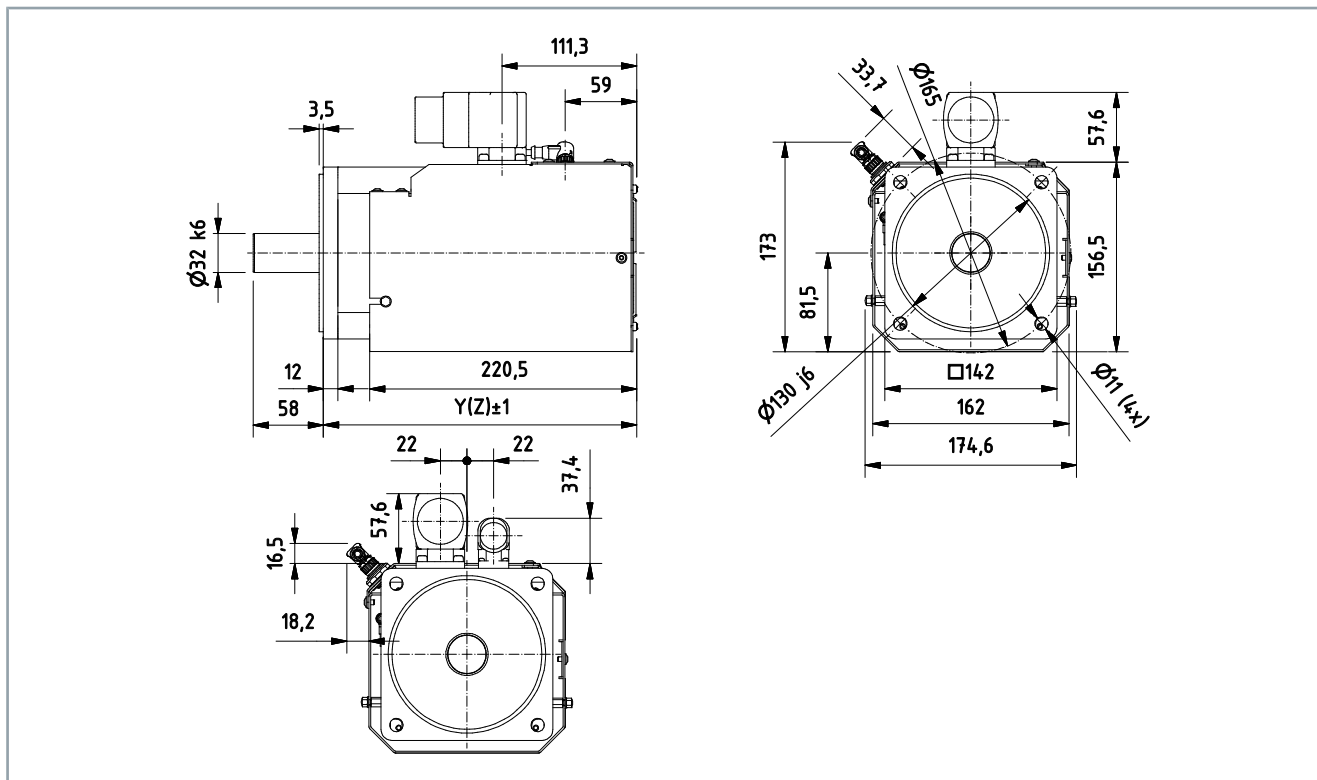

Motor	Y/Z
AM8062-xRxA-xxx0 and AM8062-xRxC-xxx0	299
AM8062-xRxB-xxx0 and AM8062-xRxD-xxx0	351
AM8063-xQxA-xxx0 and AM8063-xQxC-xxx0	339
AM8063-xQxB-xxx0 and AM8063-xQxD-xxx0	398
AM8063-xTxA-xxx0 and AM8063-xTxC-xxx0	339
AM8063-xTxB-xxx0 and AM8063-xTxD-xxx0	398
AM8064-xQxA-xxx0 and AM8064-xQxC-xxx0	398
AM8064-xTxA-xxx0 and AM8064-xTxC-xxx0	398
AM8562-xRxA-xxx0 and AM8562-xRxC-xxx0	351
AM8562-xRxB-xxx0 and AM8562-xRxD-xxx0	398
AM8563-xQxA-xxx0 AM8563-xQxC-xxx0	398
AM8563-xTxA-xxx0 AM8563-xTxC-xxx0	398

Feather key [+]

- Center bore according to DIN 332-D

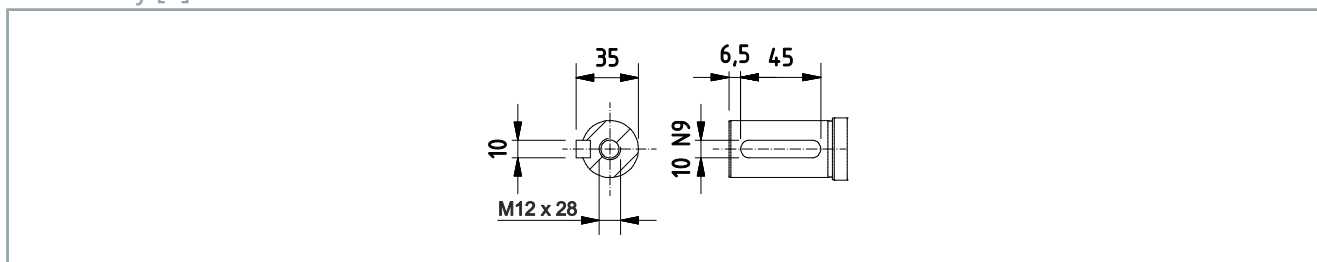

AM807x

Electrical data	AM80xx					
	71K	71N	71R	72L	72P	72T
Standstill torque M_0 [Nm]	31.80	31.80	29	54.60	54.60	50
Standstill current I_{orms} [A]	9.60	17.80	28.20	11.10	20.60	39
Maximum mechanical speed N_{max} [min ⁻¹]	5000					
Maximum nominal mains voltage U_N [V _{AC}]	480					
Peak current I_{0max} [A]	25.90	49	81.80	36.30	66.10	120
Peak torque M_{0max} [Nm]	80	79.90	78	172.50	172.40	169
Torque constant K_{Trms} [Nm/A]	3.31	1.78	1.02	4.91	2.65	1.33
Voltage constant K_{Erms} [mV/min]	231	122	70	328	180	92
Winding resistance Ph-Ph R_{20} [Ω]	1.60	0.45	0.16	1.22	0.39	0.12
Winding inductance ph-ph measured at 1 kHz L [mH]	23.40	6.50	2.20	21.40	6.45	1.85
Power supply $U_N = 115$ V						
Nominal speed N_n [min ⁻¹]	350	700	1400	200	400	1000
Nominal torque M_n [Nm]	30.60	29.20	28.10	54.50	53.50	41
Nominal output P_n [kW]	1.12	2.14	4.12	1.14	2.24	4.29
Power supply $U_N = 230$ V						
Nominal speed N_n [min ⁻¹]	800	1500	3000	500	1000	2000
Nominal torque M_n [Nm]	29	26.40	22.10	53.10	48.90	28
Nominal output P_n [kW]	2.43	4.15	6.94	2.78	5.12	5.86
Power supply $U_N = 400$ V						
Nominal speed N_n [min ⁻¹]	1500	3000	4000	1000	2000	3000
Nominal torque M_n [Nm]	26.50	19.50	18	48.90	38.20	13
Nominal output P_n [kW]	4.16	6.13	7.54	5.12	8	4.08
Nominal current I_n [A]	7.90	11.60	17.60	10.30	15.30	10.70
Power supply $U_N = 480$ V						
Nominal speed N_n [min ⁻¹]	1700	3300	4500	1100	2200	3300
Nominal torque M_n [Nm]	25.70	18.20	13.40	47.60	35.90	8
Nominal output P_n [kW]	4.58	6.29	6.31	5.48	8.27	2.76
Connection technology	M40-speedtec					
<i>Reference flange steel 375 mm x 601 mm x 10 mm</i>						

Electrical data	AM80xx					
	73N	73Q	73T	74N	74R	74T
Standstill torque M_0 [Nm]	72.6	72.6	70	92	92	92
Standstill current I_{0rms} [A]	14.70	27.90	45.60	17.40	34.90	49.80
Maximum mechanical speed N_{max} [min ⁻¹]	5000					
Maximum nominal mains voltage U_N [V _{AC}]	480					
Peak current I_{0max} [A]	51.30	97.40	180	66.70	129	180
Peak torque M_{0max} [Nm]	275	275.30	268	355	356	355
Torque constant K_{Trms} [Nm/A]	4.93	2.60	1.53	5.10	2.60	1.85
Voltage constant K_{Erms} [mVmin]	347	183	104	343	177	127
Winding resistance Ph-Ph R_{20} [Ω]	0.85	0.25	0.07	0.65	0.17	0.08
Winding inductance ph-ph measured at 1 kHz L [mH]	14.60	4.07	1.11	10.80	2.90	1.48
Power supply $U_N = 115 V$						
Nominal speed N_n [min-1]	200	500	1000	250	500	750
Nominal torque M_n [Nm]	70.50	66.50	48	85	82.50	75
Nominal output P_n [kW]	1.48	3.48	5.03	2.30	4.32	5.89
Power supply $U_N = 230 V$						
Nominal speed N_n [min-1]	500	1000	2000	500	1000	1500
Nominal torque M_n [Nm]	66.70	58.50	27.40	82	67	47.80
Nominal output P_n [kW]	3.49	6.13	5.74	4.30	7.01	7.51
Power supply $U_N = 400 V$						
Nominal speed N_n [min-1]	1000	2000	3000	1000	2000	2500
Nominal torque M_n [Nm]	58.50	38.80	10.80	67	34	19.10
Nominal output P_n [kW]	6.13	8.13	3.39	7.02	7.12	5
Nominal current I_n [A]	12	15.80	11.30	13	14.70	12.10
Power supply $U_N = 480 V$						
Nominal speed N_n [min-1]	1100	2200	3300	1200	2300	2800
Nominal torque M_n [Nm]	57	35.40	6.20	61	24	9.80
Nominal output P_n [kW]	6.57	8.16	2.14	7.65	5.78	2.90
Connection technology	M40-speedtec					terminal box
<i>Reference flange steel 375 mm x 601 mm x 10 mm</i>						

Technical data

Mechanical data	AM8071	AM8072	AM8073	AM8074
Rotor moment of inertia J [kgcm ²]	49.60	92.20	135	180
Rotor moment of inertia with brake J [kgcm ²]	68.30	110.90	154	238
Number of poles	10			
Static friction torque M _R [Nm]	0.14	0.22	0.30	0.38
Thermal time constant t _{TH} [min]	70	80	90	100
Weight [kg]	23.80	33.20	44.80	55
Weight with brake [kg]	29.30	38.70	50.30	62.7
Flange	IEC standard/DIN 42955			
Fit	j6			
Tolerance class	N			
Protection rating				
Standard housing version	IP65			
Standard shaft feedthrough version	IP54			
Shaft feedthrough with shaft sealing ring	IP65			
Paint finishes				
Properties	acrylic powder-coated			
Color	Anthracite gray; RAL 7016			
Optional holding brake [+]	AM807x			
Holding torque at 120 °C M _{BR} [Nm]	70			
Supply voltage U _{BR} [V _{DC}]	24; +6 % to -10 %			
Electrical power P _{BR} [W]	40			
Current I _{on} [A]	1.21			
Release delay time t _{BRH} [ms]	200			
Application delay time t _{BRL} [ms]	50			

Dimensional drawing

- All figures in millimeters

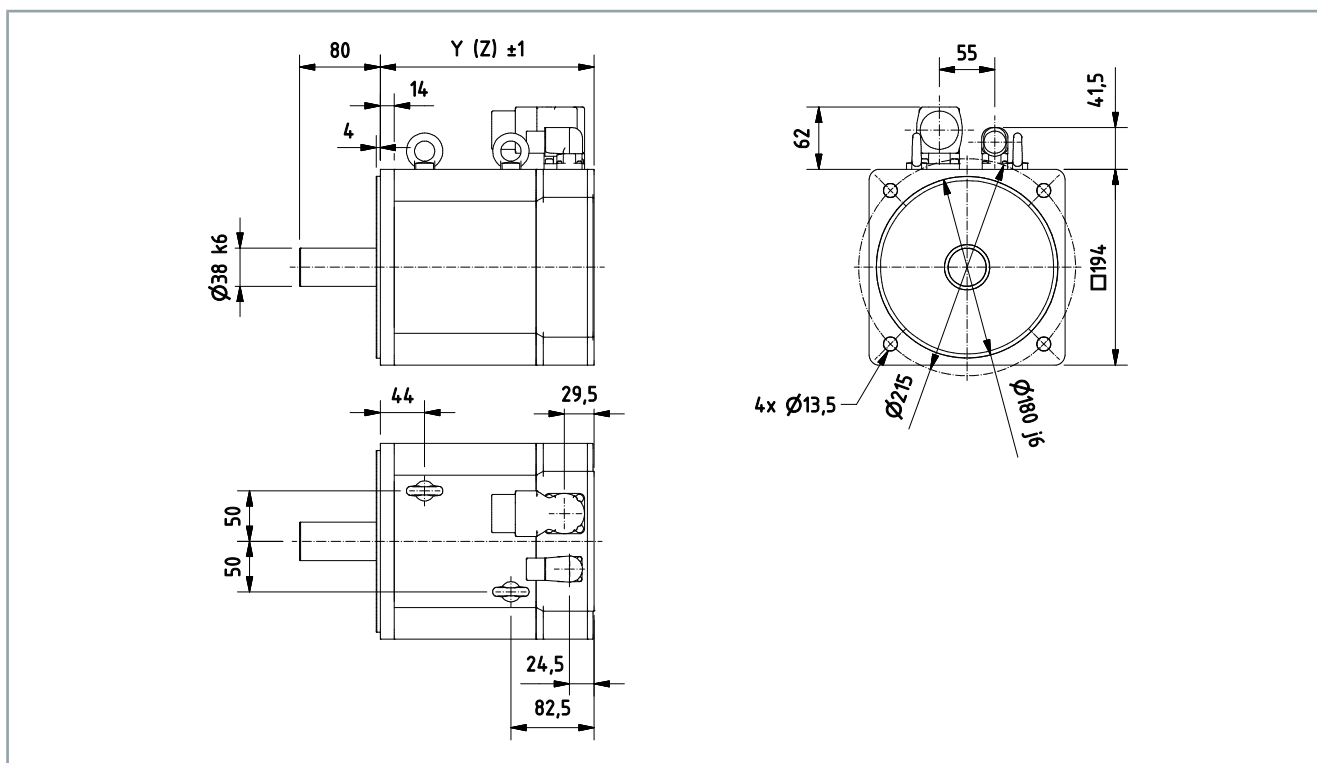

Motor	Y	Z - brake
AM8071	212	284.5
AM8072	269	341.5
AM8073	326	398.5
AM8074	398.5	459.5

Feather key [⊕]

- Center bore according to DIN 332-D

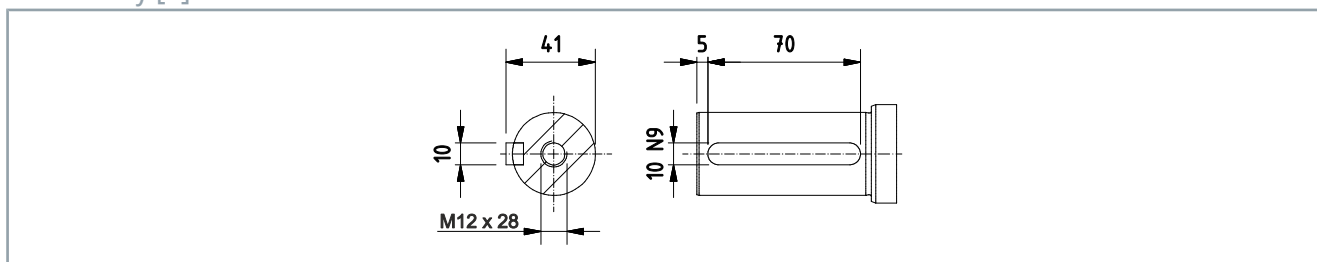

Dimensional drawing

- Illustration with OCT feedback
- All figures in millimeters

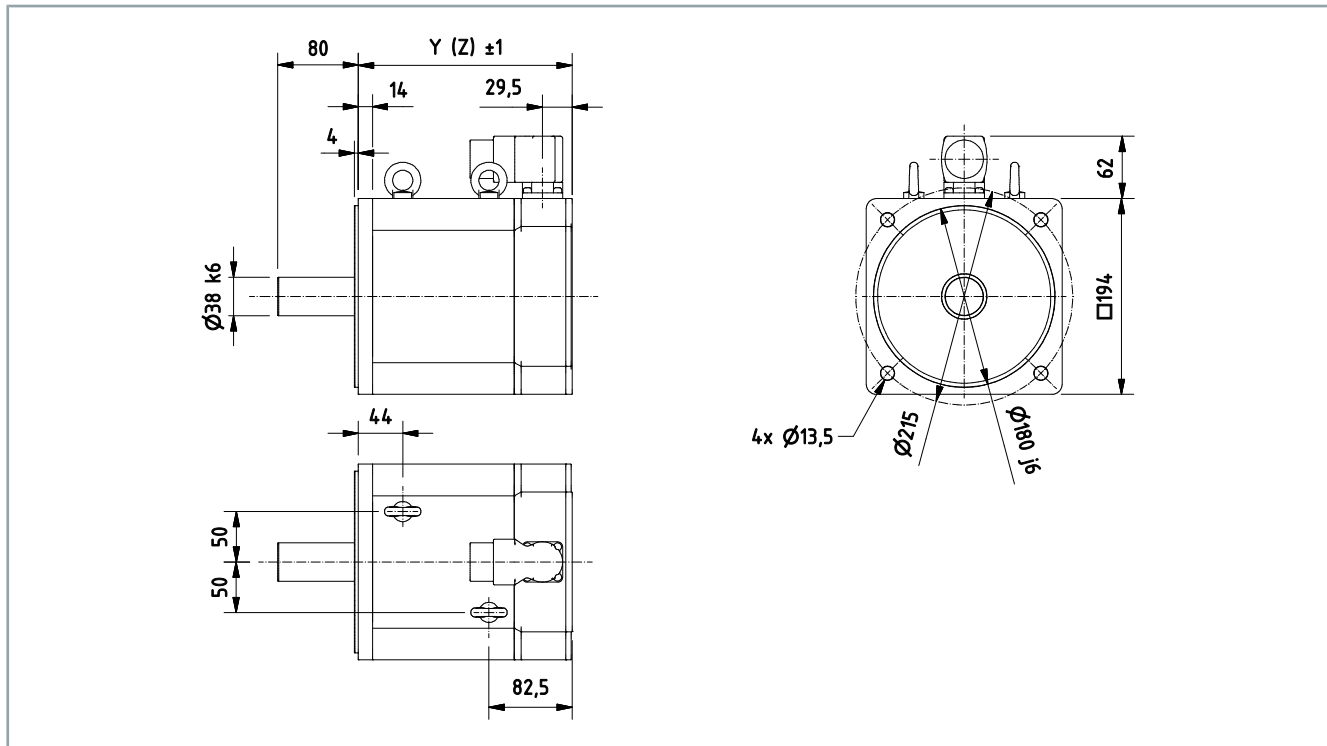

Motor	Y	Z – brake
AM8071	212	284.5
AM8072	269	341.5
AM8073	326	398.5
AM8074	398.5	459.5

Feather key [+]

- Center bore according to DIN 332-D

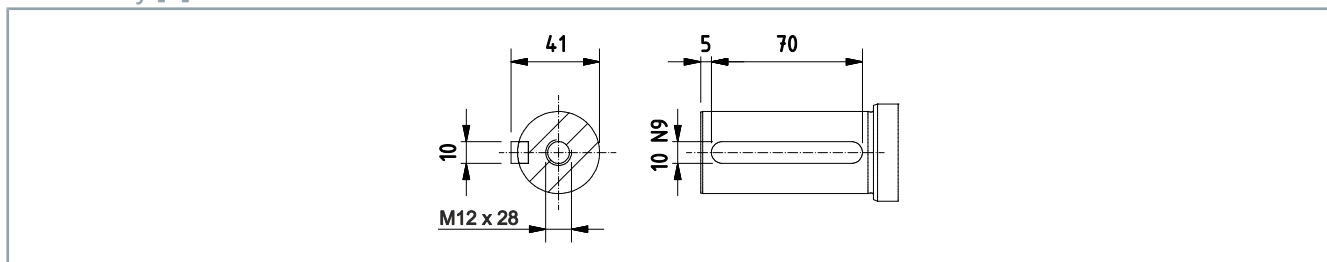

Dimensional drawing

- Illustration with terminal box and T winding
- All figures in millimeters

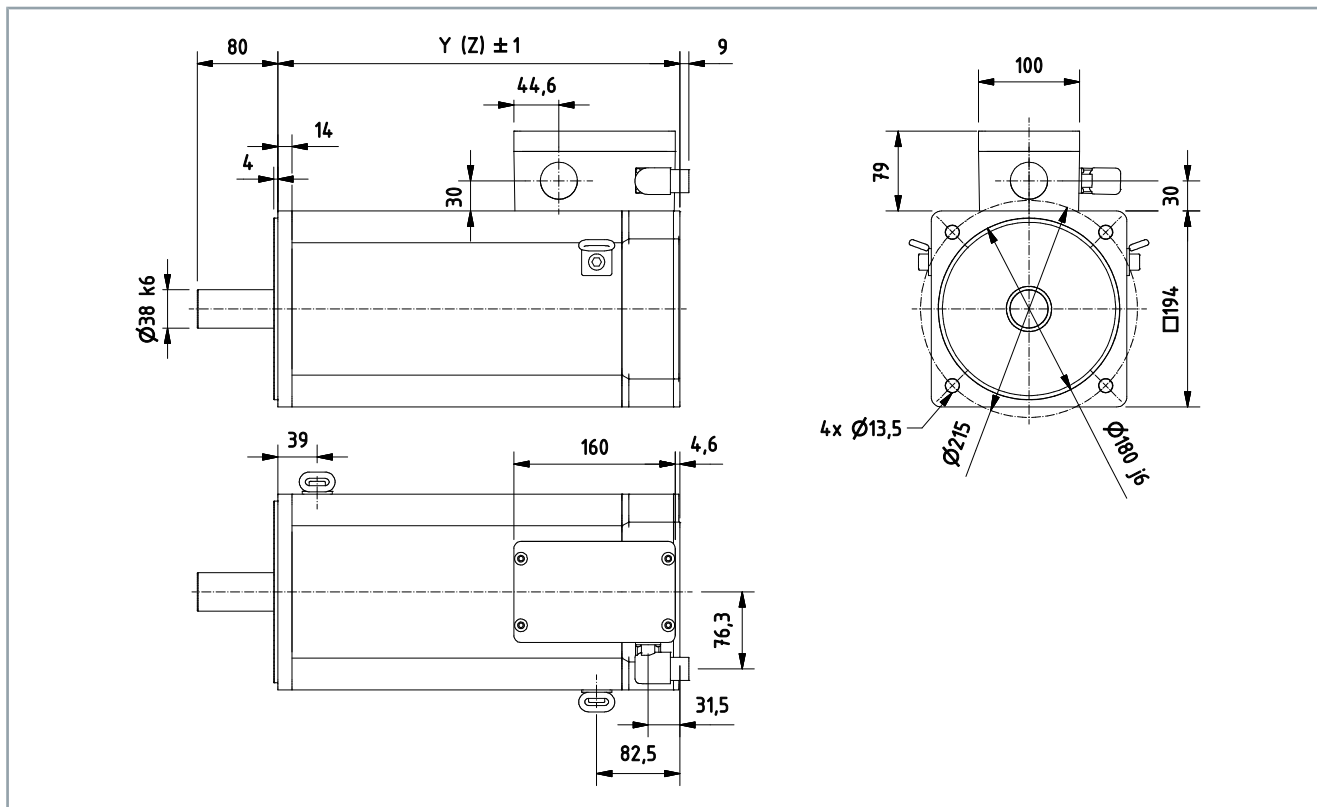

Motor	Y	Z – brake
AM8071	212	284.5

Feather key [+]

- Center bore according to DIN 332-D

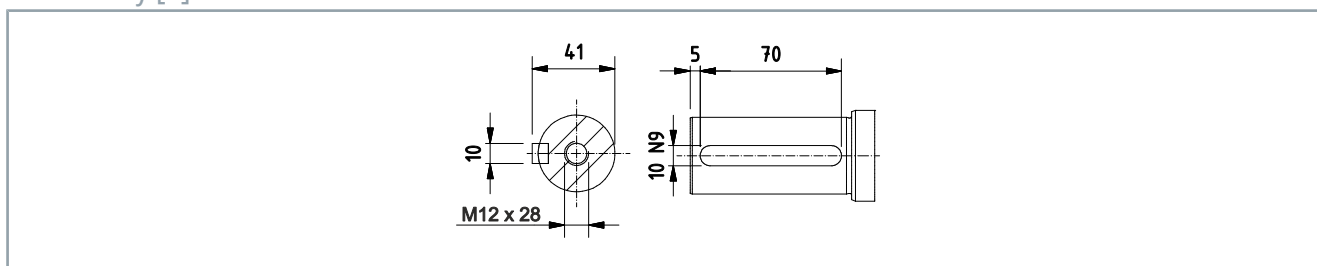

Terminal box assignment

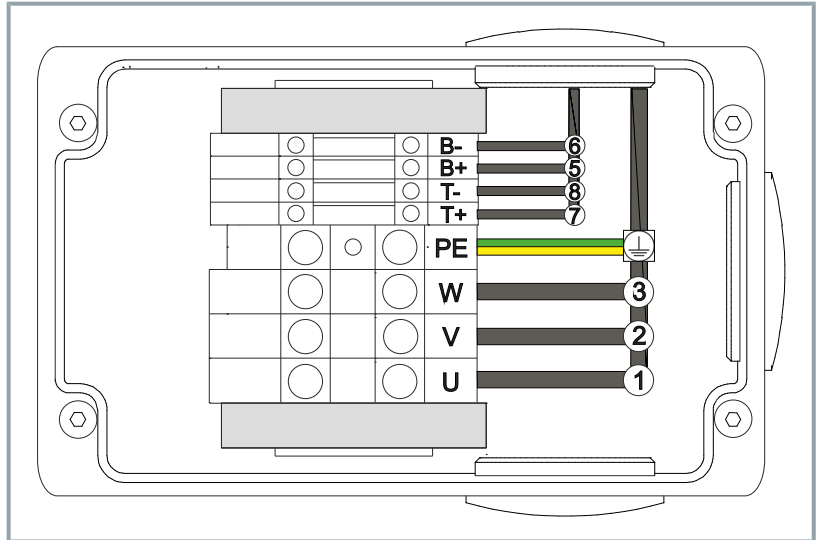

Power and feedback		Temperature and brake	
Wire	Slot	Wire	Slot
1	U	5	B+
2	V	6	B-
3	W	7	T-
4	PE	8	T+

Force diagram



Beckhoff load/force calculator

The software represents axial and radial forces on the motor shaft. The following example shows an AM8072 without a holding brake.

- [Download load/force calculator](#)

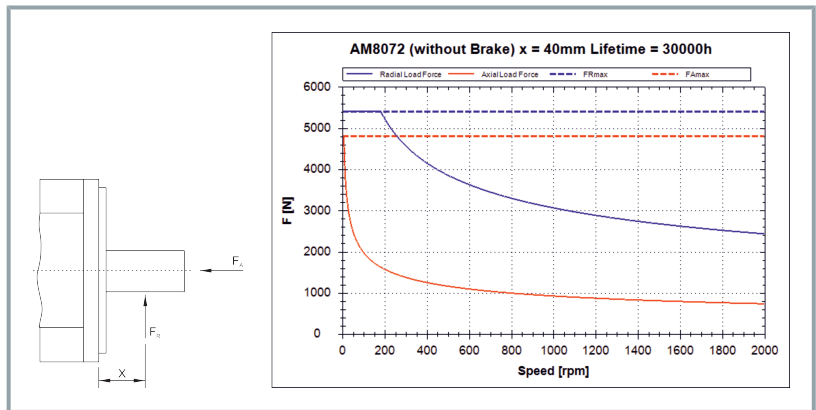

AM807x with fan cover [+]

Electrical data	AM80xx					
	71M	71P	71T	72N	72R	72U
Standstill torque M_0 [Nm]	42.80	42.80	41.20	80.70	80.70	74
Standstill current I_{orms} [A]	12.60	23.80	41.10	16.10	29.20	53
Maximum mechanical speed N_{max} [min ⁻¹]	5000					
Maximum nominal mains voltage U_N [V _{AC}]	480					
Peak current I_{0max} [A]	25.90	49	81.80	36.30	66.10	120
Peak torque M_{0max} [Nm]	80	79.91	78	172.50	172.40	168.70
Torque constant K_{Trms} [Nm/A]	3.40	1.80	1	5	2.76	1.40
Voltage constant K_{Erms} [mVmin]	231	122	70	328	180	92
Winding resistance Ph-Ph R_{20} [Ω]	1.60	0.45	0.16	1.22	0.39	0.12
Winding inductance ph-ph measured at 1 kHz L [mH]	23.40	6.50	2.20	21.40	6.45	1.85
Power supply $U_N = 115$ V						
Nominal speed N_n [min-1]	350	700	1400	200	400	1000
Nominal torque M_n [Nm]	41.10	39.20	36.60	79.90	78.30	62.30
Nominal output P_n [kW]	1.50	2.90	5.40	1.70	3.30	6.50
Power supply $U_N = 230$ V						
Nominal speed N_n [min-1]	800	1500	2900	500	1000	2000
Nominal torque M_n [Nm]	39.10	36.20	27.50	77.70	72.60	47.90
Nominal output P_n [kW]	3.30	5.70	8	4.10	7.60	10
Power supply $U_N = 400$ V						
Nominal speed N_n [min-1]	1500	2900	4000	1000	2000	3000
Nominal torque M_n [Nm]	36.20	29.20	18.10	72.60	60.10	33.80
Nominal output P_n [kW]	5.70	8.90	7.60	7.60	12.60	10.60
Nominal current I_n [A]	10.80	17.10	17.60	14.70	23.30	26.40
Power supply $U_N = 480$ V						
Nominal speed N_n [min-1]	1700	3300	4500	1100	2200	3300
Nominal torque M_n [Nm]	35.40	27.20	13.60	71.30	57.80	29.20
Nominal output P_n [kW]	6.35	9.33	6.40	8.20	13.30	10.10
Connection technology	M40-speedtec					
<i>Reference flange steel 375 mm x 601 mm x 10 mm</i>						

Technical data

Electrical data	AM80xx					
	73P	73R	73U	74R	74T	74U
Standstill torque M_0 [Nm]	104	104	95.0	129	129	129
Standstill current I_{0rms} [A]	19.80	37.40	66.50	25.80	49.40	69.20
Maximum mechanical speed N_{max} [min ⁻¹]	5000					
Maximum nominal mains voltage U_N [V _{AC}]	480					
Peak current I_{0max} [A]	51.30	97.40	180	66.70	129	180
Peak torque M_{0max} [Nm]	274.70	275.30	267.90	355	356	355
Torque constant K_{Trms} [Nm/A]	5.25	2.78	1.43	4.99	2.61	1.86
Voltage constant K_{Erms} [mV/min]	347	183	104	343	177	127
Winding resistance Ph-Ph R_{20} [Ω]	0.85	0.25	0.07	0.65	0.17	0.08
Winding inductance ph-ph measured at 1 kHz L [mH]	14.60	4.10	1.10	10.80	2.90	1.48
Power supply $U_N = 115 V$						
Nominal speed N_n [min-1]	200	400	1000	250	500	750
Nominal torque M_n [Nm]	98.20	96.80	76.50	122	115	106
Nominal output P_n [kW]	2.10	5	8	3.20	6.02	8.32
Power supply $U_N = 230 V$						
Nominal speed N_n [min-1]	500	1000	2000	500	1000	1500
Nominal torque M_n [Nm]	93.90	83.70	57.50	115	93.30	73
Nominal output P_n [kW]	5	8.80	12	6.02	9.77	11.46
Power supply $U_N = 400 V$						
Nominal speed N_n [min-1]	1000	2000	3000	1000	2000	3000
Nominal torque M_n [Nm]	83.70	63.30	17.80	93.30	51.70	24.50
Nominal output P_n [kW]	8.80	13.30	5.60	9.77	10.83	7.70
Nominal current I_n [A]	12	25.40	12.70	18.80	22.90	15
Power supply $U_N = 480 V$						
Nominal speed N_n [min-1]	1100	2200	3000	1200	2200	3200
Nominal torque M_n [Nm]	80.10	58.50	17.80	84.60	41.90	17.60
Nominal output P_n [kW]	9.30	13.60	4.50	10.63	9.65	5.90
Connection technology	M40-speedtec				terminal box	
<i>Reference flange steel 375 mm x 601 mm x 10 mm</i>						

Mechanical data	AM8071	AM8072	AM8073	AM8074
Rotor moment of inertia J [kgcm ²]	49.60	92.20	135	180
Rotor moment of inertia with brake J [kgcm ²]	68.30	110.90	154	238
Number of poles	10			
Static friction torque M _R [Nm]	0.14	0.22	0.30	0.38
Thermal time constant t _{TH} [min]	70	80	90	100
Weight [kg]	27.20	36.60	48.20	58.4
Weight with brake [kg]	32.70	42.10	53.70	66.1
Flange	IEC standard/DIN 42955			
Fit	j6			
Tolerance class	N			
Protection rating				
Standard housing version	Standard: IP20 Optional: IP65			
Standard shaft feedthrough version	IP54			
Shaft feedthrough with shaft sealing ring	IP65			
Paint finishes				
Properties	acrylic powder-coated			
Color	Anthracite gray; RAL 7016			
Optional holding brake [+]	AM807x			
Holding torque at 120 °C M _{BR} [Nm]	70			
Supply voltage U _{BR} [V _{DC}]	24; +6 % to -10 %			
Electrical power P _{BR} [W]	40			
Current I _{on} [A]	1.21			
Release delay time t _{BRH} [ms]	200			
Application delay time t _{BRL} [ms]	50			

Dimensional drawing

- Illustration with fan cover [+]
- All figures in millimeters

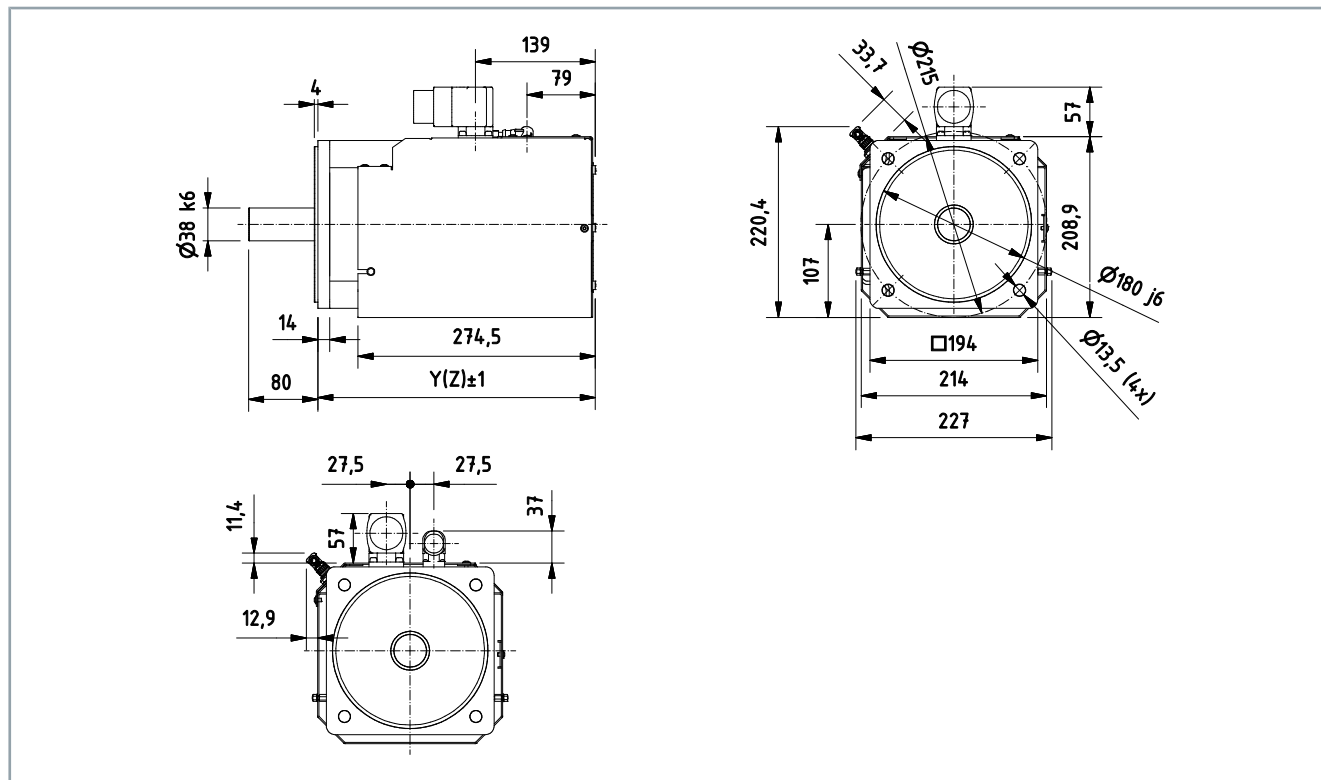

Motor	Y/Z
AM8071-xxxA-xxx0 and AM8071-xxxC-xxx0	321
AM8071-xxxB-xxx0 and AM8071-xxxD-xxx0	393.5
AM8072-xxxA-xxx0 and AM8072-xxxC-xxx0	378
AM8072-xxxB-xxx0 and AM8072-xxxD-xxx0	450.5
AM8073-xxxA-xxx0 and AM8073-xxxC-xxx0	435
AM8073-xxxB-xxx0 and AM8073-xxxD-xxx0	507.5
AM8074-xR0A-xxx0 and AM8074-xR0C-xxx0	507.5

Feather key [+]

- Center bore according to DIN 332-D

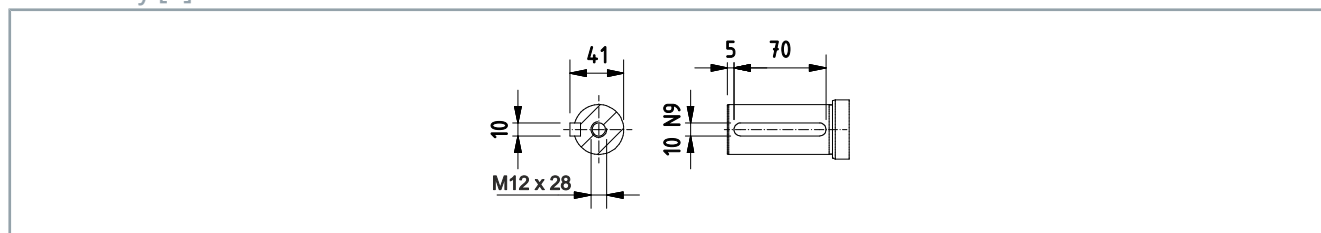

Dimensional drawing

- Illustration with fan cover [+], terminal box and T-U winding
- All figures in millimeters

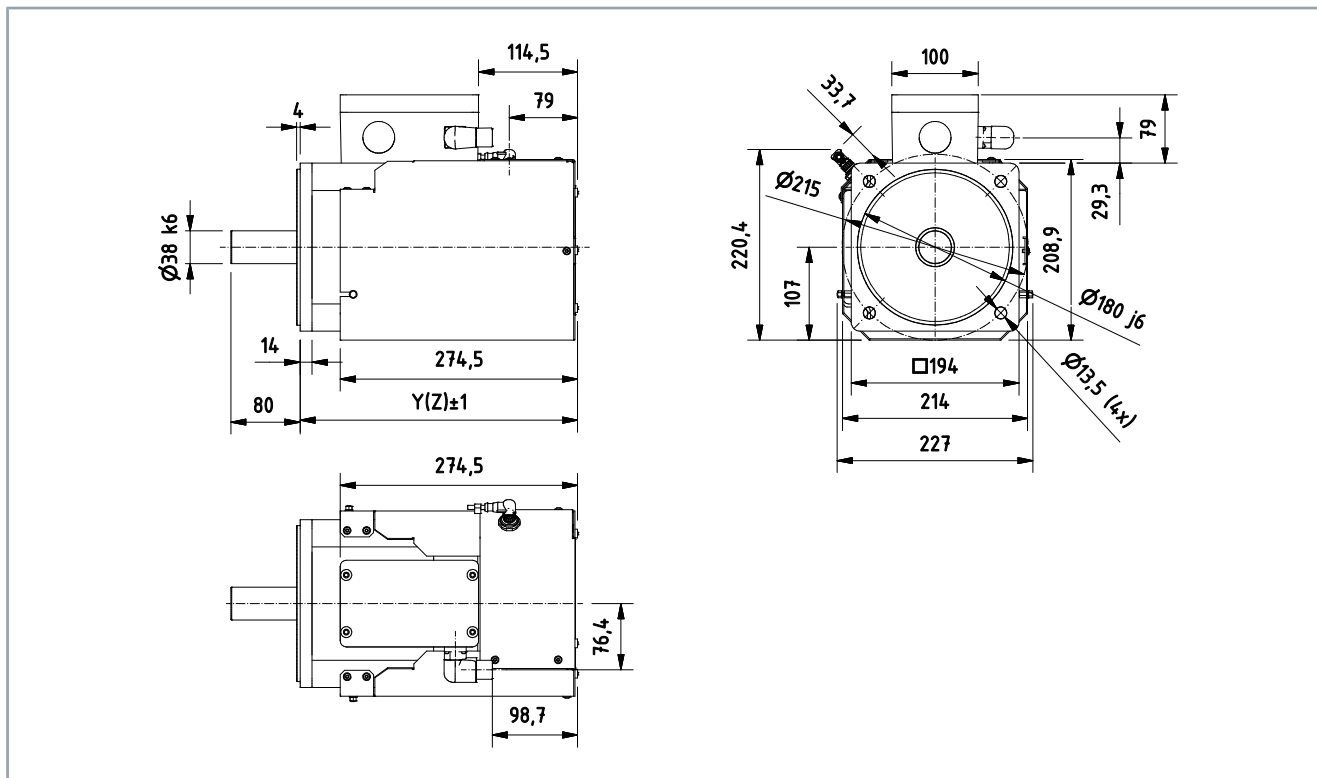

Motor	Y/Z
AM8074-xT0A-xxxx and AM8074-xT0C-xxxx	507.5
AM8074-xU0A-xxxx and AM8074-xU0C-xxxx	507.5

Feather key [+]

- Center bore according to DIN 332-D

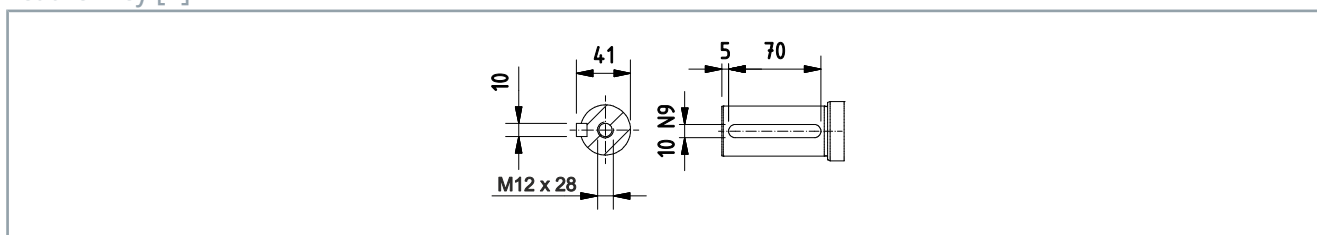



Check the scope of supply for missing or damaged parts

Check your delivery for completeness. If any parts are missing or became damaged during transport, contact the carrier, vendor or our service department immediately.

Check the shipment for the following contents:





- AM8000 or AM8500 series motor with yellow protective cap
- Short information

When ordering a motor with external fan:

- Fan cover [+] with fittings

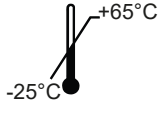
Packaging

Instructions for handling are printed on the packaging:

Symbol	Explanation
	These are the permitted maximum and minimum temperatures at which the device may be stored and transported.
	This is the correct position for the packaging.
	Protect the packaging against wetness.
	The contents are fragile.



Avoid damage to the motors and resulting loss of warranty

Observe the conditions and the following chapters on transport and storage.

Failure to observe the conditions may result in damage to the motors and void the warranty.



Do not remove the yellow protective cap

Do not remove the yellow protective cap on the drive shaft.

The protective cap protects against mechanical damage and environmental influences. If you remove the protective cap, the shaft may be damaged.

Conditions

During transport and storage ensure that the motors and individual components are not damaged. Observe the specifications in the following chapters and comply with the following conditions:

- Climate category: 2K3 according to EN 60721
- Temperature: -25 °C to +70 °C, maximum fluctuation 20 K/hour
- Air humidity: 5 % to 95 % relative humidity, no condensation
- Use of suitable means of transport
- The device should be transported and stored in a horizontal position
- Use of the vendor's original packaging

The table shows the maximum stacking height at which you may store and transport the motors on a pallet in the original packaging:

Motor type	Stacking height [pieces]
AM801x	10
AM802x	10
AM803x or AM853x	6
AM804x or AM854x	6
AM805x or AM855x	5
AM806x or AM856x	2
AM807x	1

Transport

⚠ WARNING

Do not enter the area below suspended motors

Use suitable means of transport and secure the motor against falling.
If the motor falls down, this can lead to serious or even fatal accidents.



Avoid hard impacts on the motor

Use suitable means of transport and secure the motor against falling.
Falling and hard impacts will damage the motor and motor components.

AM8x3x to AM8x5x

Transport of the series AM8x3x to AM8x5x without aids.

AM8x6x

Transport of the AM8x6x series with eye slings.

⚠ WARNING

Fasten eye sling correctly

Only attach the eye sling to the motor housing. Make sure the load is balanced. Do not attach the eye sling to the shaft.
Lifting with the eye sling when the load is not balanced can lead to the motor slipping out and seriously or even fatally injuring people as well as damaging the motor.

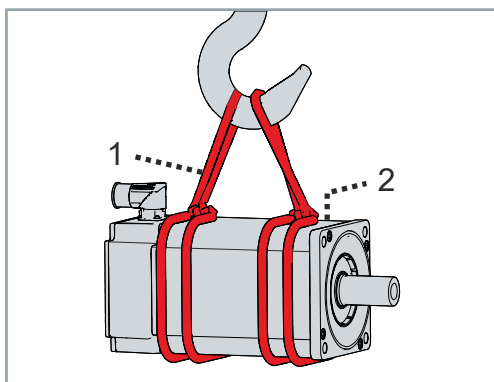

- ▶ Attach eye sling [1] to motor housing [2]
- ▶ Ensure that the eye sling is balanced at both ends of the motor
- ▶ Lift the servomotor with a suitable hoist

AM807x

AM807x series is equipped with eyebolts as standard. Use only these eyebolts to attach lifting equipment.

⚠ WARNING

Use the eyebolts correctly

Make sure the load is balanced. Do not attach lifting gear to the shaft.

Attaching the lifting gear unbalanced can lead to slipping of the motor and fatally injure people and damage the motor.

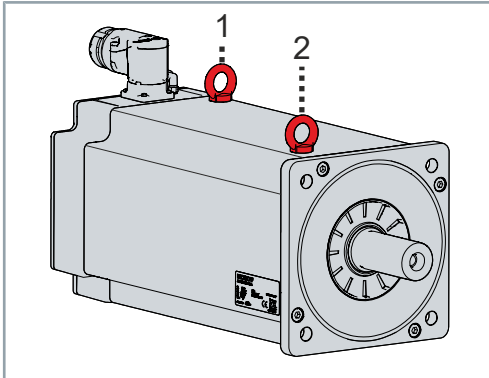

- ▶ Attach suitable lifting equipment to eyebolts 1 and 2
- ▶ Lift the servomotor with a suitable hoist

Long-term storage



Observe the maximum storage time

Do not exceed the maximum storage time of two years.

Exceeding the specified maximum storage time can lead to changes in the properties of the lubricant used and damage the motor during subsequent operation.



Perform recurring inspections

Check the motor for proper condition every six months.

Damage to the motor or maintenance work not carried out will affect the service life of the installed components and parts.



Prevent the formation of condensation

Keep the ambient temperature constant. Avoid solar radiation and high humidity.

Condensation water can lead to damage during subsequent operation or to rust formation.

The motors can be stored for shorter or longer periods. For storage we always recommend the original packaging. Adhere to the conditions specified in the chapter: "Transport and storage", [Page 79].

The motors are protected against chemical and aggressive substances, class 1C2, chemical substances and 1B2, biological conditions.

Ensure the storage space is vibration-free.

Mounting position



Observe the maintenance intervals and mounting positions

Carry out maintenance at regular intervals.

In the IM V3 horizontal mounting position, liquid which has been left on the flange for a longer period can penetrate the motor through capillary action. In mounting position IM V1 liquid can escape.

If you do not observe the maintenance intervals, the motor may overheat depending on the mounting position. Ingress and leakage of liquids may damage the motor.

The standard installation position of the motors is the design IM B5 according to DIN 60034-7.

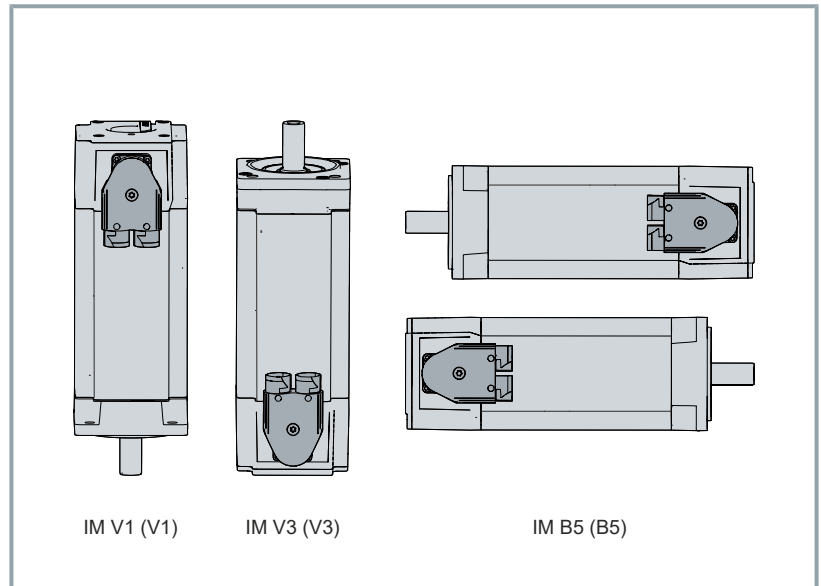

Feedback



Feedback exchange

The feedback system installed can only be replaced with an identical system. It is not possible to change the feedback system retrospectively. The feedback may only be exchanged by Beckhoff service.

The table below provides information about system accuracies and resolutions of the motor feedback systems:

Feedback	Resolution	System accuracy	Comment
OCT, single-turn OCT, multi-turn	18-bit	± 120 angular seconds $\sim 0.03^\circ$	Standard: AM801x – AM8x6x Standard fan: AM805x – AM8x6x
Hiperface, single-turn Hiperface, multi-turn	18-bit	± 120 angular seconds $\sim 0.03^\circ$	Standard: AM807x
OCT, single-turn OCT, multi-turn	23-bit	± 45 angular seconds $\sim 0.0125^\circ$	From firmware v2.10
OCT, single-turn OCT, multi-turn	24-bit	± 25 angular seconds $\sim 0.0069^\circ$	SIL 2 From firmware v2.10
Resolver	14-bit	± 600 angular seconds $\sim 0.17^\circ$	Option

Protection equipment

The LPTC-600 temperature sensor is installed in all motors from the AM8000 and AM8500 series.

The LPTC-600 is integrated in the monitoring system of the servo drive when using the pre-assembled motor cable. Configure the servo drive according to the motor temperature warning at 120 °C and the switch-off temperature at 140 °C.

The LPTC-600 is identical to the KTY 84,130 used previously.

LPTC-600 sensor

The following table shows the resistance values of the temperature sensor:

Temperature [°C]	T/°C [%/K]	LPTC-600 Resistance [Ω]			Temperature error [K]
		minimum	Nominal value	maximum	
-40	0.84	340	359	379	± 6.48
-30	0.83	370	391	411	± 6.36
-20	0.82	403	424	446	± 6.26
-10	0.80	437	460	483	± 6.16
0	0.79	474	498	522	± 6.07
10	0.77	514	538	563	± 5.98
20	0.75	555	581	607	± 5.89
25	0.74	577	603	629	± 5.84
30	0.73	599	626	652	± 5.79
40	0.71	645	672	700	± 5.69
50	0.70	694	722	750	± 5.59
60	0.68	744	773	801	± 5.47
70	0.66	797	826	855	± 5.34
80	0.64	852	882	912	± 5.21
90	0.63	910	940	970	± 5.06
100	0.61	970	1000	1030	± 4.90
110	0.60	1029	1062	1096	± 5.31
120	0.58	1089	1127	1164	± 5.73
130	0.57	1152	1194	1235	± 6.17
140	0.55	1216	1262	1309	± 6.63
150	0.54	1282	1334	1385	± 7.10
160	0.53	1350	1407	1463	± 7.59
170	0.52	1420	1482	1544	± 8.10
180	0.51	1492	1560	1628	± 8.62

Shaft end A

The A-side is used for force transmission via a backlash-free and frictional connection. This is achieved by means of a coupling and a cylindrical shaft end according to DIN 748-3 with a centering bore at the front according to DIN 332-2. Alternatively, forces can be transmitted via a frictional connection and a feather key groove according to DIN 6885/ISO 2491.

Radial forces

- Motors driven via pinion/toothed belt
- Permissible values depend on the speed

Axial forces

- Pinion or pulley mounted on the shaft
- For example, when operating angular gear units

Preferred backlash-free coupling elements

- Double-coned collets and metal bellows couplings



Calculation tool for radial and axial forces

- Beckhoff AM8000 motors radial forces/axial forces, service life

Power derating

Derating may be necessary at high ambient temperature or when operating at a great height above sea level. In addition, some motors may experience power reductions depending on the feedback system installed or the holding brake [+]. The reduction affects the standstill current and the standstill torque.

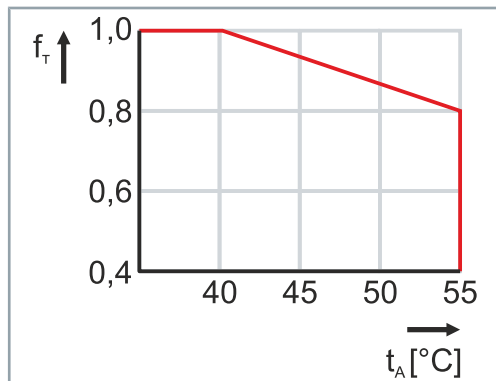

Ambient temperature

f_T = Temperature utilization factor

t_A = Ambient temperature in °C

Calculation of the performance data if the specified temperature limit > 40 °C to 55 °C is exceeded:

$$M0_{red} = M0 \times fT$$

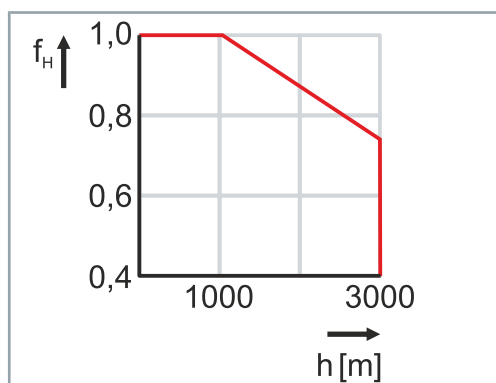

Installation altitude

f_H = Altitude utilization factor

h = Altitude in meters

Calculation of the performance data if the specified installation altitude is exceeded > 1000 m to 3000 m:

$$M0_{red} = M0 \times fH$$

Ambient temperature and installation altitude

Calculation of the power data when exceeding the specified limits:

Ambient temperature > 40 °C, altitude > 1000 m and < 3000 m:

$$M0_{red} = M0 \times fT \times fH$$

Carry out all work with great care and without time pressure.

Flange mounting

The following table provides information on components for mounting the motor on the machine or system:

Quality of the Hexagon Socket Head Cap Screw DIN EN ISO 4762 = 8.8				
Motor	Bore diameter [mm]	Bolt size	Tightening torque [Nm]	washer DIN EN ISO 7089
AM801x	4.3	M4 x 16	3	4.3
AM802x	5.5	M5 x 16	5.5	5.3; DIN 7980
AM8x3x	6	M5 x 16	5.5	5.3; DIN 7980
AM8x4x	7	M6 x 20	10	6.4
AM8x5x	9	M8 x 25	25	8.3
AM8x6x	11	M10 x 30	50	10.5
AM807x	13.5	M12 x 40	85	13; DIN 7980

Output elements

⚠ WARNING**Secure moving parts against ejection**

Make sure there are no moving parts on or in the machine during operation. Feather keys [+] are only secured during transport.

Unsecured parts can be ejected from the machine during operation and cause serious or fatal injuries.

**Protect the motor from inadmissible load**

Avoid bending components during transport or handling and do not change any insulation distances. Avoid hard shocks to the shaft end, the ball bearings or the feedback system. Furthermore, note vibration qualities and vibration resistance. If necessary, provide additional support for the motor.

An impermissible load on the components can have a negative effect on the performance of the motor. Impacts on the motor shaft impair the concentricity of the motor.

**Ensure adequate grounding via the protective conductor**

The thermal connection of the motor flange determines the power dissipation.

Ensure adequate earthing via the protective conductor or the motor flange.

Bearing load during installation

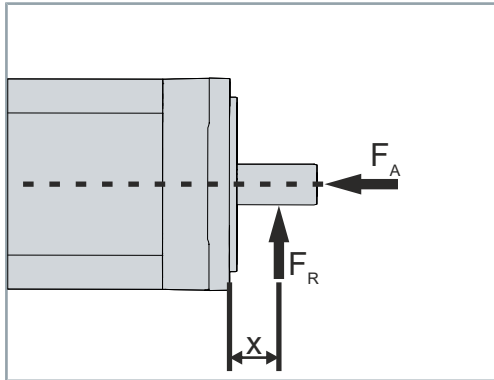

Avoid mechanically overdetermined support of the motor shaft through rigid coupling and additional external support.

When assembling output elements, care must be taken to minimize the load on the shafts and bearing due to shear forces such as radial force F_R and axial force F_A . Axial loads shorten the service life and can lead to malfunctions of the holding brake [+].

Special features when using toothed belt drives:

When using a toothed belt drive, the radial and axial loads on the shaft must not be exceeded. Excessive load can lead to fatigue fracture of the motor shaft. Be sure to read the chapter Technical data.

Storage

The servomotors are equipped with sealed grooved ball bearings. The fixed bearing is located on the B-side of the servomotor and the floating bearing on the A-side; shaft output side of the servomotor. Oscillatory bearing movements $< 180^\circ$ shaft rotation are not permissible. Use the Beckhoff load/force calculator for a detailed calculation of the bearing forces on the motor shaft.

Servomotor	A-bearing sizes	B-bearing sizes
AM801x	609 D22	699
AM802x	6001	609 D22
AM8x3x	6203	6201
AM8x4x	6204	6203
AM8x5x	6205	6203
AM8x6x	6307	6305
AM807x	6309	6307

Mounting

⚠ WARNING

Do not touch hot output elements without personal protective equipment

Only handle hot output elements, such as couplings or pulleys, with special thermal gloves. Avoid prolonged contact with hot components.

Hot components can cause severe burns to body parts and limbs.



Do not mount the drive element offset

Place the drive element centered and straight on the motor shaft.

An offset will cause unacceptable vibration and the destruction of the ball bearings and the coupling.

- ▶ Warm up the output elements according to manufacturer's instructions
- ▶ Remove the protective cap
- ▶ Degrease and clean the motor shaft
- ▶ Remove the output element from the oven and transport it to the workstation
- ▶ Place output element [1] centered and straight on the motor shaft [2]

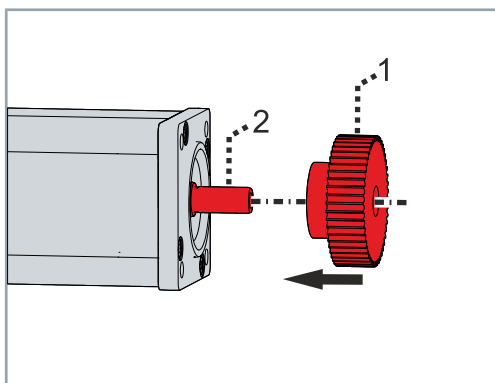

- ▶ Insert washer [3] with screw [4] of strength class 8.8 and nut [5] into the locking thread [6] of the motor shaft
- ▶ Tighten nut [5]

The output element is pulled onto the motor shaft by the nut.

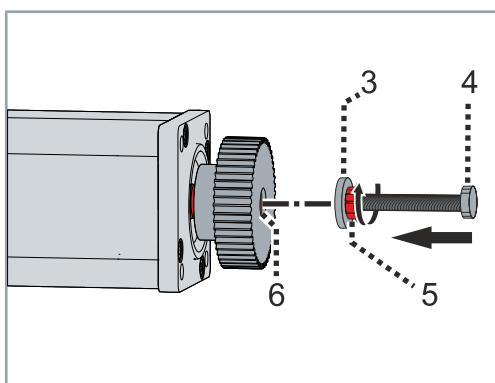

Dismantling

Use only backlash-free and friction-locked collets, gear pullers or suitable couplings to dismantle the output elements.

▶ Degrease the motor shaft

▶ Screw puller [3] and intermediate disc [2] into the locking thread of the motor shaft

▶ Place the puller fully on the drive element [1]

▶ Pull the output element [1] with the puller [3] from the motor shaft

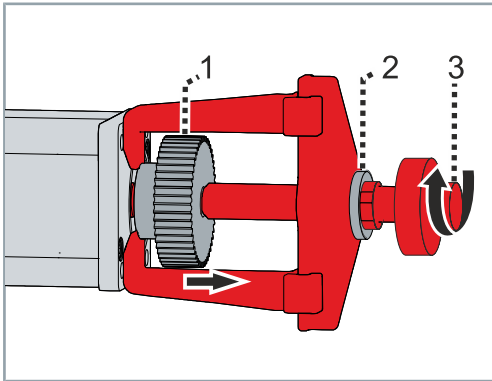

Fan cover [+]

A motor is cooled by an external device using forced ventilation. This facilitates higher performance. The air flow passes through the fan cover [+] over the motor housing.

Mounting



Clean the working environment

Workplaces and their immediate surroundings must be tidy and dust-free. Avoid dirt in tapped holes. *Disregarding this can lead to malfunctions and damage to the components.*

- ▶ Attach the motor to the machine

Only for AM807x series:

- ▶ If necessary, loosen and remove the eyebolts on the motor housing

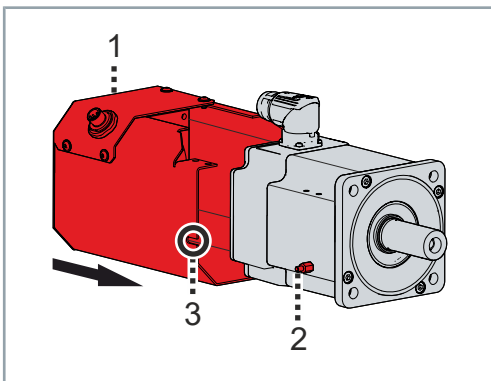

- ▶ Push the fan cover [+] [1] up to the mechanical stop
- ▶ Make sure that on both sides of the motor the elongated holes [3] are aligned with the screw connection devices [2]

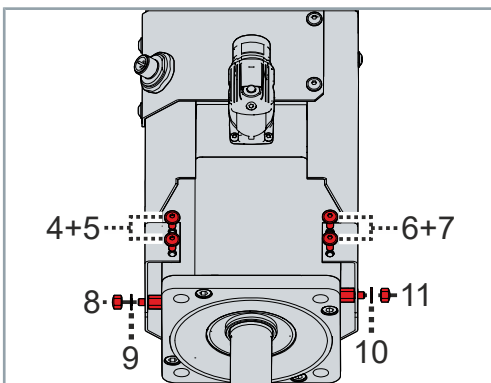

- ▶ Fit screws [4] to [7]
- ▶ Fit nuts [8] and [11] with washers [9] and [10]
- ▶ Observe tightening torques:

Screws	Nuts
3 Nm size 2.5	2.5 Nm, size 7

Use Beckhoff control cable

Use the pre-assembled control cable ZK4054-6400-0xxx to connect the fan cover [+]

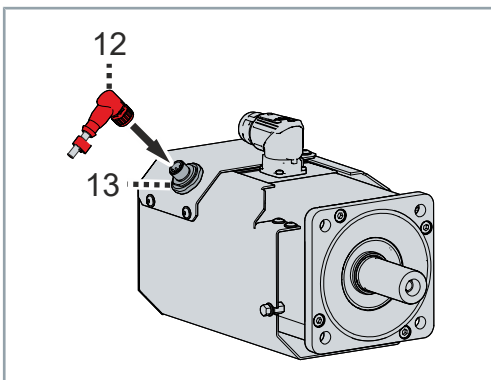

- ▶ Plug the power connector [12] into the power box [13] of the motor
- ▶ Hand-tighten power connector [12] and check for tight fit

Performance data of the external fan

The table below shows the electrical and mechanical specifications of the external fan:

Technical data	AM8x5x	AM8x6x	AM8x7x
Supply voltage U_{LA} [V _{DC}]	24		
Electrical power P_{LA} [W]	4.6	9.8	31.2
Current I [A]	0.19	0.41	1.3
Protection class	IP20		

Assignment plan of the power connector

The following table shows the assignment of the power connector of the external fan:

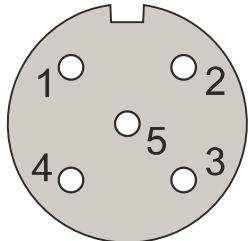
Socket configuration	Contact in the connector	Assignment on the cable
	1	PE: Green/yellow
	2	+24 V _{DC} : Brown
	3	Not used
	4	GND: Blue
	5	Not used



Documentation on the control cable ZK4054-6400-0xxx

The data sheet of the control cable can be found under:
www.beckhoff.com → Download → Data sheets → Cables and wires

Connection technology

Beckhoff supplies prefabricated power and feedback cables. Mating connectors are not included in the scope of supply. For the selection of the necessary cables, refer to the Beckhoff documentation for the connecting cables [+]. In the documentation you will find a complete overview of the available cables and information on the technical data.



For interference-free data transmission, please note:

- Maximum number of mating cycles for the connectors: 500 cycles
- Maximum number of rotations of the power box: 10

If the maximum number of mating cycles or rotations is exceeded, clean data transmission can no longer be guaranteed. This results in signs of wear.

Power box

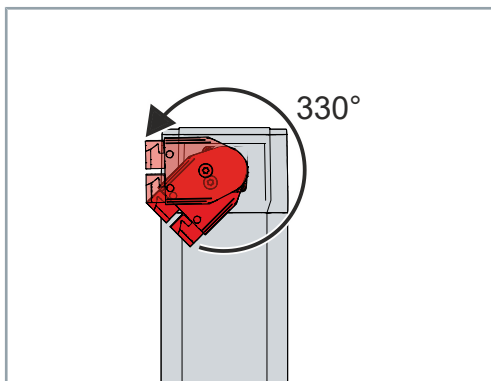

The motors are equipped with angled, rotatable power boxes for the power supply and the feedback signals. This applies only to resolvers, Hiperface, iTec[®] connectors, M23 connectors and M40 connectors. The power box can be rotated by 330°.

Cables



Avoid soiling and damage

When connecting the socket and connector, make sure that the poles and the inside of the component are not soiled or damaged. *Failure to do so may adversely affect the function of the connections.*



Hint for trouble-free application and assembly:

- Wiring in accordance with applicable regulations and standards
- Pre-assembled and shielded Beckhoff cables

Beckhoff offers pre-assembled cables for faster and flawless installation of the motors. These cables are tested with regard to the material used, shielding and connection type. Perfect functioning and compliance with legal regulations, such as EMC and UL, are guaranteed. The use of other cables can cause unexpected malfunctions and result in exclusion of warranty.

Choice of cable

Beckhoff motor cables and feedback cables differ from one another in the method of laying, the type of connection and the core cross-section. The table below shows the assignment of the different Beckhoff cables to the matching servomotors and servo drives.

Motor cables for AX5000 servo drives

Servomotor	Servo drive	Order key	Laying method
Flange size F1 to F3			
AM801x, AM802x, AM803x	AX5101 to AX5106,	ZK4500-8022-xxxx	Highly dynamic
	AX520x	ZK4500-8062-xxxx	Torsion-capable
Flange size F4 to F6			
AM804x, AM854x, AM805x, AM855x, AM806x, AM856x up to P-winding	AX5101 to AX5112, AX520x	ZK4500-8003-xxxx	Fixed installation
		ZK4500-8023-xxxx	Highly dynamic
		ZK4500-8063-xxxx	Torsion-capable
	AX5118, AX5125	ZK4500-8004-xxxx	Fixed installation
		ZK4500-8024-xxxx	Highly dynamic
ZK4500-8064-xxxx	Torsion-capable		
Flange size F6 to F7			
AM806x, AM856x from Q-winding, AM807x	AX5112 to AX5125	ZK4500-8025-xxxx	Highly dynamic
	AX5140	ZK4500-8027-xxxx	
	AX5160	ZK4504-8027-xxxx	
		ZK4506-8027-xxxx	
AM8074 from T-winding			
AM806x, AM856x from Q-winding, AM807x	AX5172	ZK4504-8018-xxxx	dynamic
		ZK4506-8018-xxxx	
AM8074 from T-winding			

Motor cables for AX8000 multi-axis servo system

Servomotor	Servo drive	Order key	Laying method
Flange size F1 to F3			
AM801x, AM802x, AM803x	AX8108, AX8206	ZK4800-8022-xxxx	Highly dynamic
		ZK4800-8062-xxxx	Torsion-capable
Flange size F4 to F6			
AM804x, AM854x, AM805x, AM855x, AM806x, AM856x up to P-winding	AX8108, AX8206	ZK4800-8003-xxxx	Fixed installation
	AX8118	ZK4800-8023-xxxx	Highly dynamic
		ZK4800-8063-xxxx	Torsion-capable
		ZK4800-8004-xxxx	Fixed installation
		ZK4800-8024-xxxx	Highly dynamic
	ZK4800-8064-xxxx	Torsion-capable	
Flange size F6 to F7			
AM806x,	AX8118	ZK4800-8025-xxxx	Highly dynamic
AM856x from Q-winding	AX8525	ZK4800-8525-xxxx	Fixed installation
AM807x	AX8540	ZK4800-8527-xxxx	

Extension cables for AX5000 and AX8000

Extension cable	AX5000 – motor cable	AX8000 – motor cable
ZK4501-8022-xxxx	ZK4500-8022-xxxx	ZK4800-8022-xxxx
ZK4501-8062-xxxx	ZK4500-8062-xxxx	ZK4800-8062-xxxx
ZK4501-8003-xxxx	ZK4500-8003-xxxx	ZK4800-8003-xxxx
ZK4501-8023-xxxx	ZK4500-8023-xxxx	ZK4800-8023-xxxx
ZK4501-8063-xxxx	ZK4500-8063-xxxx	ZK4800-8063-xxxx
ZK4501-8004-xxxx	ZK4500-8004-xxxx	ZK4800-8004-xxxx
ZK4501-8024-xxxx	ZK4500-8024-xxxx	ZK4800-8024-xxxx, ZK4800-8524-xxxx
ZK4501-8064-xxxx	ZK4500-8064-xxxx	ZK4800-8064-xxxx
ZK4501-8025-xxxx	ZK4500-8025-xxxx	ZK4800-8025-xxxx, ZK4800-8525-xxxx
ZK4501-8027-xxxx	ZK4500-8027-xxxx, ZK4504-8027-xxxx	ZK4800-8027-xxxx

Feedback cables for AX5000

Servomotor	Order key	Laying method	
AM802x, AM803x	ZK4530-8110-xxxx ZK4531-8110-xxxx	dynamic	
AM804x, AM854x, AM805x, AM855x, AM806x, AM856x AM807x	ZK4530-8010-xxxx ZK4531-8010-xxxx		
AM802x AM803x	ZK4510-8110-xxxx ZK4511-8110-xxxx		
AM804x, AM854x, AM805x, AM855x, AM806x, AM856x AM807x	ZK4510-8020-xxxx ZK4511-8020-xxxx		Highly dynamic

Connectors

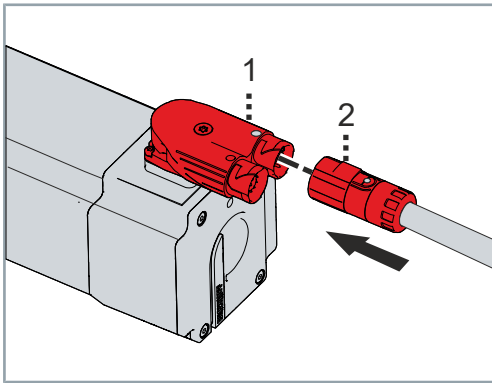

- ▶ Push iTec connector [2] straight onto power box [1] of the motor
- ▶ Make sure that the marking points face each other

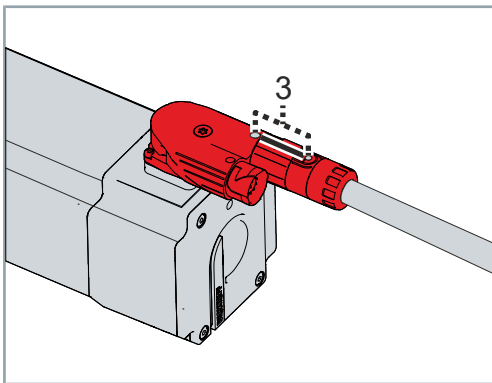

- ▶ Pay attention to the "click" sound
 - ▶ Make sure that all marking points [3] are in alignment
- The iTec connector is then fully engaged.

Important

If the iTec connector does not automatically lock into place on the power box during the rotational movement:

- ▶ Turn the iTec connector by hand into the correct position so that the marking points [3] are aligned

Rotary joints

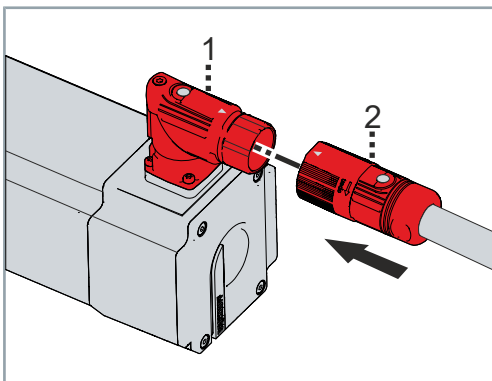

- ▶ Push speedtec connector [2] straight onto power box [1] of the motor
- ▶ Make sure that the marking arrows face each other

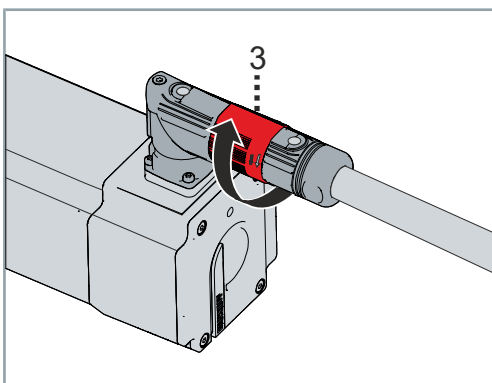

- ▶ Turn the cap nut [3] clockwise

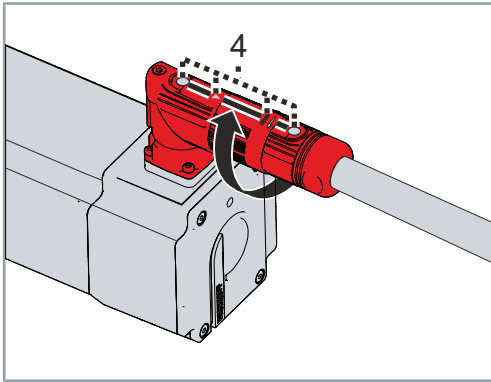

- Make sure that all markings and the lettering "open" [4] are aligned

The speedtec connector is then fixed properly.

terminal box



Avoid soiling and damage

When dismantling the cover and connecting the terminal box and cables, make sure that no foreign objects or dirt particles enter the terminal box, the clamping ring or the M40 thread on the terminal box.

Failure to do so may adversely affect the function of the connections.



Assembly of the power cable and feedback cable

When assembling the cables, note that the size of the blind plug thread in the terminal box is M40.

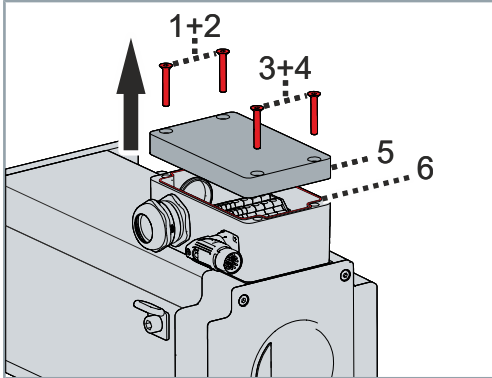

- ▶ Make sure that the rubber seal [6] in the cover [5] is not lost or damaged
- ▶ Loosen and remove screws [1] to [4]
- ▶ Remove cover [5]

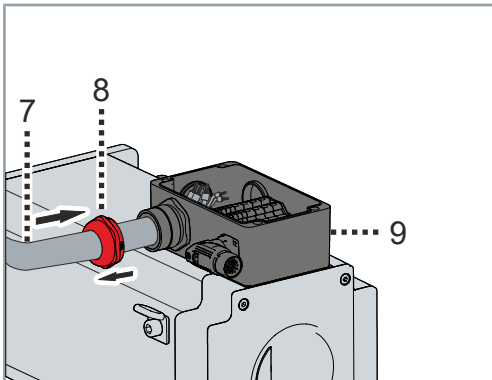

- ▶ Loosen clamping ring [8]
- ▶ Insert motor cable [7] through clamping ring [8] into terminal box [9]

Motor cable	Order details
10 mm ² for motors with terminal box	ZK4506-8027-xxxx
16 mm ² for motors with terminal box	ZK4506-8018-xxxx

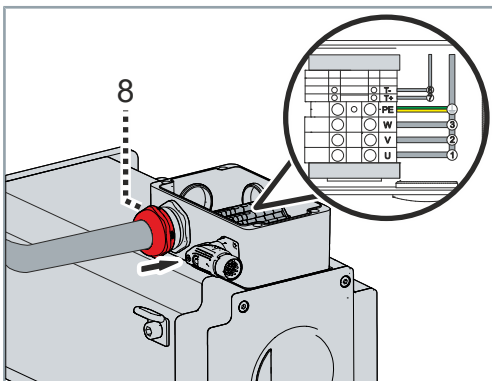

- ▶ Fasten clamping ring [8] to the terminal box
- ▶ Connect the cable ends to the terminal according to the assignment diagram

Important

The assignment diagram of the terminal box can be found below: Technical data AM807x.

- ▶ Make sure that the seal is correctly placed on the terminal box
- ▶ Re-install the cover [5]

Connector assignment

Beckhoff offers various power connectors and feedback connectors. All connectors are IP65 rated. A protective conductor connection according to VDE 0627 is provided on the housing.

OneCableTechnology

The following tables show the connector assignment:

iTec connector

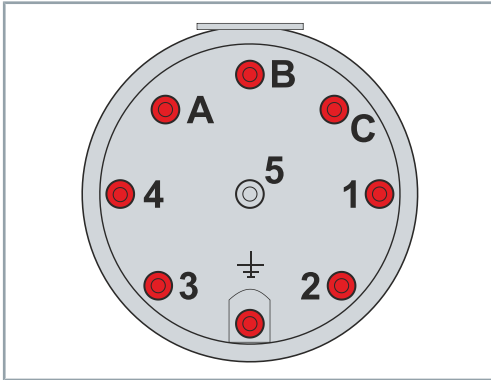

Pin assignment iTec connector		
Contact	Function	Core identification
A	U	Black/1
B	W	Black/3
C	V	Black/2
1	Brake+	5
2	Brake-	6
3	Temperature+/OCT+	White
4	Temperature-/OCT-	Blue
5	---	---
PE	PE	Green/yellow

M23 connector

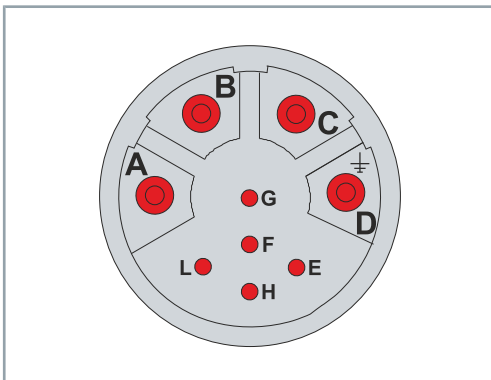

Pin assignment M23 connector		
Contact	Function	Core identification
A	U	Black/1
B	V	Black/2
C	W	Black/3
D	PE	Green/yellow
E	Temperature-/OCT-	Blue
F	Shield	Shield
G	Brake+	Black/5
H	Temperature+/OCT+	White
L	Brake-	Black/6

M40 connector

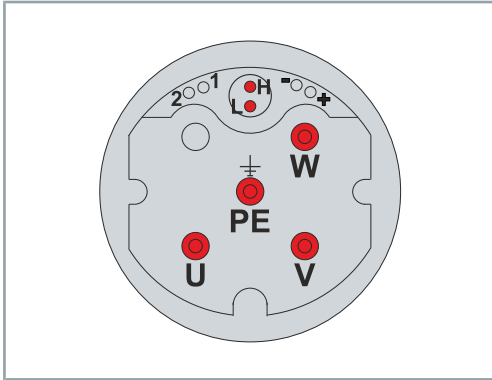

Pin assignment M40 connector

Contact	Function	Core identification
U	U	black/1
V	V	black/2
W	W	black/3
PE	PE	Green/yellow
N	---	---
+	Brake+	Black/5
-	Brake-	Black/6
1	---	---
2	---	---
H	Temperature+/OCT+	White
L	Temperature-/OCT-	Blue

Feedback

The following tables show the connector assignment:

Encoder

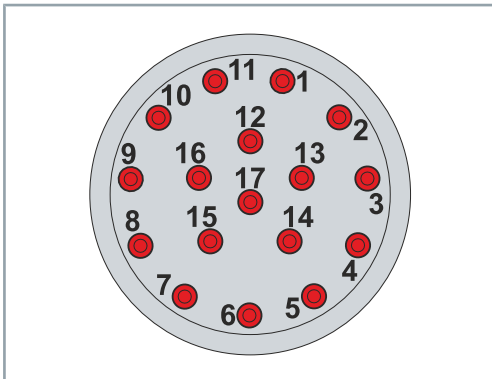

Pin assignment of 17-pin Speedtec connector

Contact	Function
1	SIN-
2	GND 9 V
3	COS-
4	---
5	DX+/Data
6	U _s 9 V
7	---
8	---
9	SIN+
10	---
11	COS+
12	---
13	DX-/Data
14	---
15	---

Resolver

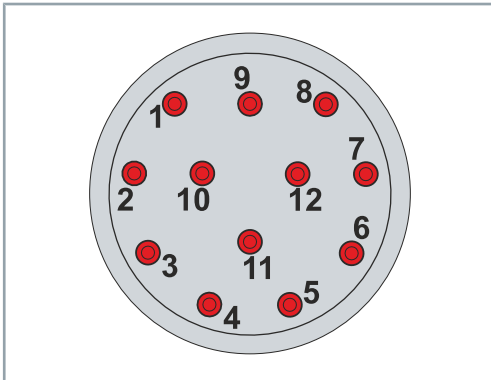

Pin assignment of 12-pin Speedtec connector

Contact	Function
1	---
2	---
3	COS-/S3
4	SIN-/S4
5	REF-/R2
6	---
7	COS+/S1
8	SIN+/S2
9	REF+/R2
10	---
11	---
12	---

Resolver

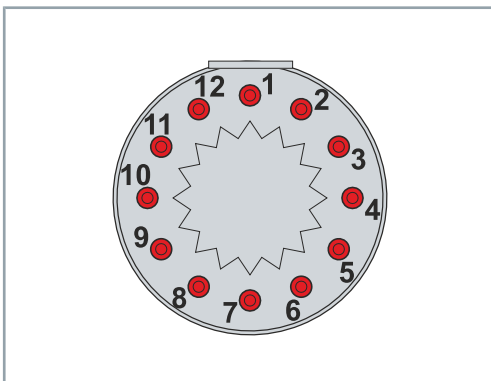

Pin assignment of yTec 12-pin connector

Contact	Function
1	---
2	---
3	COS-/S3
4	SIN-/S4
5	REF-/R2
6	---
7	COS+/S1
8	SIN+/S2
9	REF+/R1
10	---
11	---
12	---



Exemplary commissioning

The procedure for commissioning is described as an example. A different method may be appropriate or necessary, depending on the application of the components.

Before commissioning

Pay attention to the following points before commissioning:

- ▶ In the case of multi-axis systems, commission each drive unit separately
- ▶ Read the operating instructions for the servo drive
- ▶ Check drive for damage
- ▶ Check mounting and alignment
- ▶ Tighten screw connections correctly
- ▶ Installing mechanical, thermal and electrical protective devices
- ▶ Check the wiring, connection and proper grounding of the drive and servo drive

In case of motors with holding brake [+]

- ▶ Check the function of the holding brake [+]
- ▶ In case of malfunction: apply 24 V_{DC}, release brake
- ▶ Check emergency stop functions

In case of motors with fan cover [+]

- ▶ Check connection and function
- ▶ Fan must rotate freely, pay attention to grinding noises
- ▶ Check the direction of rotation of the fan

During commissioning

Pay attention to the following points during commissioning:

- ▶ Check function and adjustment of attachments
- ▶ Observe information for environment and operation
- ▶ Check protective measures against moving and live parts

Configuration

Beckhoff recommends the use of servo drives and motors from Beckhoff in combinations, and configuration in the Beckhoff Twin-CAT DriveManager.

Carry out the instructions in the operating manual for servo drives:

- ▶ Build Project and Choose Target System
- ▶ Implement devices by scanning or manually
- ▶ Configure devices, determine and set motor type
- ▶ Create axis configuration
- ▶ Set scaling factor and speeds
- ▶ Check status and activate control system

Prerequisites during operation

Pay attention to the following points during operation:

- ▶ Listen for atypical noises
- ▶ Check for unusual smoke formation
- ▶ Always check drive surfaces and cables for dirt, leaks, moisture or dust
- ▶ Check temperature development
- ▶ Check for lubricant leakage
- ▶ Observe recommended maintenance intervals
- ▶ Check function of safety devices

In case of motors with fan cover [+]:

- ▶ Check air intakes for contamination
- ▶ Check that the motor and fan cover [+] are firmly seated
- ▶ Observe tightening torques

After operation

WARNING

Place the machine or plant in a safe state

Make sure that the rotor comes to a complete stop.

When the holding brake [+] is released, the rotor moves without remanent torque. Rotating components can lead to serious injuries.

WARNING

Ensure safe condition for cleaning work

Basically, electronic devices are not fail-safe. The condition is always safe when the unit is switched off and not energized. For cleaning work, bring the connected motors and the machine into a safe state.

Carrying cleaning work during operation can lead to serious or fatal injuries.



Do not submerge or spray the motor

Only wipe the motor with a cleaner and a cloth.

Cleaning by immersion may result in surface and motor damage and leakage problems as a result of impermissible solutions.

Contamination, dust or chips can have a negative effect on the function of the components. In the worst case, contamination can lead to failure. Therefore, clean and service the components at regular intervals.

Cleaning materials

Carefully clean the components with a damp cloth or brush.

For cleaning, we provide an overview of cleaning agents to which the motors may be exposed up to a maximum concentration of 3%. You will also receive information about non-approved cleaning agents.

Approved

Cleaning agents	Chemical formula
Acetyl chloride	CH ₃ COCl
Aluminum chloride	AlCl ₃ -6H ₂ O
Ammonium chloride	NH ₄ Cl
Antimony trichloride	SbCl ₃
Barium chloride	BaCl ₂ -2H ₂ O
Chlorine; also chlorine water, chlorinated lime and chlorobenzene	Cl ₂
Chlorosulfuric acid	HSO ₃ Cl
Hydrogen chloride gas	HCl
Chromic acid	CrO ₃
Iron(III) chloride	FeCl ₃
Hydrogen fluoride	HF
Carnallite	KClMgCl ₂ -6H ₂ O
Aqua regia	HCl + HNO ₃
Magnesium chloride	MgCl ₂ -6H ₂ O
Monochloroacetic acid	CH ₂ ClCOOH
Sodium chloride; common salt	NaCl
Sodium hydroxide	NaOH
Sodium peroxide	Na ₂ O ₂
Sulfuric acid	H ₂ SO ₄
Tartaric acid	COOH; CHO ₂ COOH
Tin-II IV-chloride	SnCl ₂ -2H ₂ O SnCl ₄

Not applicable

Cleaning agents	Chemical formula
Aniline hydrochloride	C ₆ H ₅ NH ₂ HCl
Bromine	Br ₂
Sodium hypochlorite; bleaching solution	NaClO
Mercury (II) chloride	HgCl ₂
Hydrochloric acid	HCl

Intervals

Under nominal conditions, the motor components have different operating hours. We have provided you with a list of maintenance work and intervals for the associated components below:

Component	Interval	Maintenance
Ball bearing	30000 operating hours	Replace bearing
Motor	2500 operating hours/annually	Check motor for bearing noises If noises are detected: do not continue to operate motor; replace bearing
Shaft sealing ring	5000 operating hours	Perform visual inspection Lubricate the shaft sealing ring Recommended lubricants: "Mobilgrease TM FM22" from Mobil In case of damage and pressure drop: Replace shaft sealing ring
Cables	Regular intervals	Perform visual inspection and check for damage As required: Replace cables
	5 million bending cycles	Replace cables
Fan cover [+]	half-yearly	Perform visual inspection and check for damage In the event of unbalance: Clean fan Contact Beckhoff Service In case of damage: Contact Beckhoff Service
Power box	500 mating cycles	In case of damage: Contact Beckhoff Service
Connector	10 turning cycles	In case of damage: Contact Beckhoff Service

Connection cables

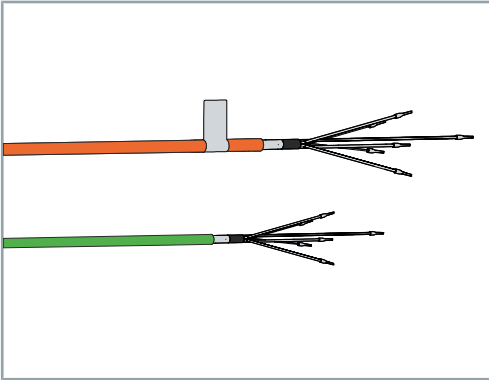

There are orange power cables and green feedback cables for the connection between motor and servo drive. Information on the connection of a motor to a servo drive or the multi-axis servo system can be found in the chapter: Electrical installation.

iTec extension

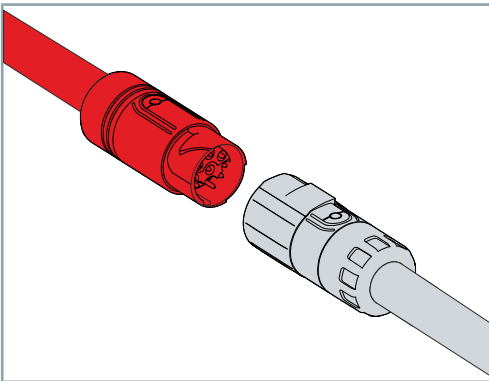

Motor cables can be extended using an iTec extension cable.

speedtec extension

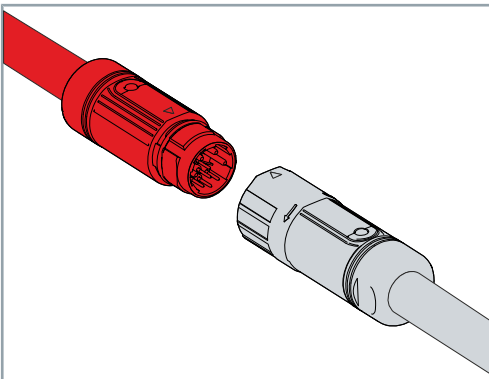

Motor cables can be extended using an speedtec extension cable.

Shaft sealing ring

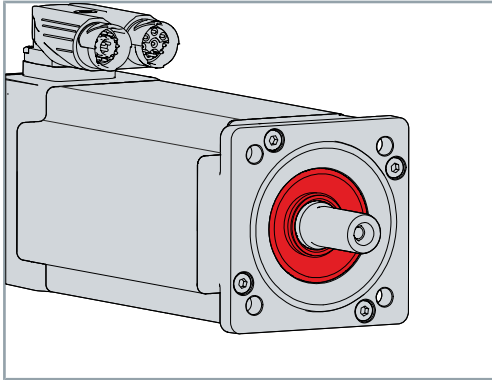

The FKM radial shaft sealing ring serves to seal against splash water and to protect the motor shaft against the ingress of dust or dirt. This increases the protection class of the shaft feed through to IP65.

The radial shaft-sealing ring can be replaced at any time. Please note, however, that the exchange may lead to a reduction in the nominal values.

Gear unit



Axial load due to thermal expansion of the motor shaft

To avoid displacement of the motor shaft at high temperatures, use couplings as length compensation.

Directly mounted bevel gears or helical gear wheels can exceed the axial load of the floating bearing on the shaft end A.

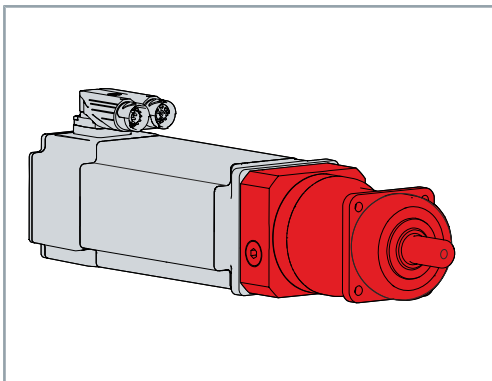

A gear unit serves to transmit a moment of force or a torque and is used on the motor as an output element. Information on flange sizes for combinations of motor and gear unit can be found in the chapter: Type key.

The following table describes a selection of faults. Depending on the application, other causes may be responsible for the malfunction. Conspicuous control behavior is the result of incorrect parameterization of the servo drive.

With multi-axis systems such as the AX8000, malfunctions may have different causes.

Error	Cause																		
Motor standstill no starting	1	2			5														
Motor runs sluggishly	1		3		5	6													
Noises when starting up			3		5	6					11								
Noises during operation	1		3		5	6					11								
High temperature at idling speed				4			7	8	9										
High temperature under load	1		3				7	8	9										
Uneven running behavior										10	11								
Grinding noises												12							
Brake fault													13	14					
Output stage fault					5									15	16				
Feedback error																17	18		
No brake effect					5	6													
Leakages																			19

Fault correction

Number	Cause	Solution
1	Servo drive not enabled	Set ENABLE signal and enable servo drive
	Motor overload	Check the load and if necessary reduce it, then restart and enable the servo drive. Set ENABLE signal
	Mechanical blockage of the motor	Check mechanics and release blockage
	Holding brake [+] not released	Check the control configuration of the holding brakes [+] and reconfigure if necessary
2	Phase interruption in the power supply or reversed motor phases	Check servo drive and supply cables and replace any defective cables
3	Phase interruption after power supply; switching on	Check servo drive and supply cables and replace any defective cables
	Power cable or feedback cable with defective shield	Check earth connection and shielding
4	Short-circuit in the voltage supply cable for the holding brake [+]	Replace defective cable, measure and check cable after replacement
	Output voltage of the servo drive too low	Check the settings in the configuration and read out the electronic type plate of the motor again
	Defective holding brake [+]	Replace motor, then measure and check
5	Short circuit or earth leakage in the motor cable	Replace defective motor cable, then measure and check
6	Power connector not fitted correctly	Check the connectors on the power connector and on the motor
	Interruption in the feedback or motor cable	Check cables for broken wire or crushing. Replace defective cables, then measure and check.

Number	Cause	Solution
7	Required holding torque too high	Check design or configuration and adjust if necessary
8	Inlet temperature too high	Lower and adjust the inlet temperature
	No more cooling water available	Replenish cooling water and check regularly
9	Motor heat dissipation system not functioning	Clean the surface of the motors and the servo drive as well as the heat sinks and exhaust air slots. Check the installation depths of the servo drives and motors.
10	Power cable or feedback cable with defective or insufficient shielding	Check earth connection and shielding
11	Servo drive gain set too high.	Reconfigure the parameters of the servo drive and adjust them if necessary
12	Contamination or foreign bodies inside the motor	Send in motor. The repair is carried out by the vendor.
	Rotating parts chafing on the housing or motor components	Inspect chafing parts and readjust if necessary
	Defective bearings; irreparable bearing damage	Send in motor. The repair is carried out by the vendor.

Fault correction

Number	Cause	Solution
13	Short-circuit in the voltage supply cable for the holding brake [+]	Replace defective cable, then measure and check
14	Inadequate power supply of the holding brake [+]	Check the settings in the configuration and read out the electronic type plate of the motor again
15	Short circuit or earth leakage in the motor	Replace defective motor, then measure and check
16	Insufficient power supply	Check the settings in the configuration and read out the electronic type plate of the motor again
17	Interruption or crushing in the feedback cable	Check cables for broken wire or crushing. Replace defective cables, then measure and check.
18	Feedback connector not fitted correctly	Check the position of the feedback connector
	Loose fit of the feedback connector or no contact of the plug contacts with the power socket of the motor.	Check the connector assembly. Contact Beckhoff Service if necessary.
19	Cooling water pipes and/or water connections leaky or defective	Determine leakage If necessary: Seal

Disassembly may only be carried out by qualified and trained personnel.

Read the chapter Documentation notes.

When disposing of electronic waste, make sure that you dispose of it in accordance with the regulations applicable in your country. Read and follow the instructions for proper disposal.

Disassembly

WARNING

Risk of injury from leaking oil

Prevent oil from leaking. Let it cool down before starting work. Soak up any leaked oil with approved binding agents. Mark the danger spot.

Leaking oil can cause slips and falls, resulting in serious or fatal injury. Hot oil can cause severe burns.



Do not remove components from the products

Only

Beckhoff Automation GmbH & Co. KG is permitted to remove components.

Contact Beckhoff Service for further information.

Removal of the motor from the machine

- ▶ Remove cables and electrical connections
- ▶ Cool and drain liquids, then remove
- ▶ Remove supply lines and water hoses
- ▶ Loosen and remove the fixing screws of the motor
- ▶ Transport the motor to the work area or store it

Disposal

Depending on your application and the products used, ensure the professional disposal of the respective components:

Cast iron and metal

Dispose of cast and metal parts as scrap metal for recycling.

Cardboard, wood and foam polystyrene

Dispose of packaging materials made of cardboard, wood or foam polystyrene in accordance with the regulations.

Plastics and hard plastics

You can recycle parts made of plastic and hard plastic via the recycling depot or re-use them depending on the component designations and markings.

Oils and lubricants

Dispose of oils and lubricants in separate containers. Hand over the containers at the used oil collection station.

Batteries and rechargeable batteries

Batteries and rechargeable batteries may also be marked with the crossed-out trash can symbol. You must separate these components from the waste and are legally obliged to return used batteries and rechargeable batteries within the EU. Observe the relevant provisions outside the area of validity of the EU Directive 2006/66/EC.



Electronic components

Products marked with a crossed-out waste bin must not be disposed of with general waste. Electronic components and device are considered as waste electrical and electronic equipment for disposal. Observe the national regulations for the disposal of old electrical and electronic equipment.

Returning to the vendor

In accordance with the WEEE-2012/19/EU directives, you can return used devices and accessories for professional disposal. The transport costs are borne by the sender.

Send the used devices with the note "For disposal" to:

Beckhoff Automation GmbH & Co. KG
"Service" Building
Stahlstrasse 31
D-33415 Verl

In addition, you have the option to contact a local certified specialist company for the disposal of used electrical and electronic appliances. Dispose of the old components in accordance with the regulations applicable in your country.

Standards

Product standard EN 61800-3:2004+A1:2012

"Adjustable speed electrical power drive systems. EMC requirements and specific test methods"

EN 60034-1:2010+Corr.:2010

"Rotating electrical machines – Rating and performance"

RoHS: EN 50581:2012

"Technical documentation for the assessment of electrical and electronic products with respect to the restriction of hazardous substances"

Guidelines

2014/35/EU

Low Voltage Directive



2014/30/EU

EMC Directive

2011/65/EU

RoHS Directive

Test centers

	<p>The motors do not fall within the scope of the Machinery Directive. However, Beckhoff products are designed and evaluated in full compliance with all relevant regulations for personal safety and use in a machine or system.</p>
	<p>The motors meet all the requirements of the Eurasian Economic Union. These include Russia, Belarus, Armenia, Kazakhstan and Kyrgyzstan. The EAC logo can be found on the name plate.</p>
	<p>The motors comply with UL requirements and are certified as cURus components for the US and Canadian markets in accordance with the standards applicable in the USA and Canada. The cURus logo can be found on the name plate.</p>

EU conformity



Provision

Beckhoff Automation GmbH & Co KG will be pleased to provide you with EU declarations of conformity and manufacturer's declarations for all products on request.

Please send your request to: info@beckhoff.com

CCC conformity



Export to Chinese Economic Area

Beckhoff synchronous servomotors of the AM8000 & AM8500 series are not subject to the **China Compulsory Certificate (CCC)**. The products are exempt from this certification and can be exported to the Chinese economic area.

UL conformity



Certification for USA and Canada

Beckhoff synchronous servomotors from the AM8000 & AM8500 series are approved as certified cURus components, E355768, for the American and Canadian economic area. The motors may be used as components in a system with UL-Listing test mark.

A			
Accessories			
Connection cables	111		
Gear unit	112		
iTec extension	111		
Shaft sealing ring	112		
speedtec extension	111		
C			
Cables	96		
Select	96		
Cleaning	108		
Cleaning materials	108		
Commissioning	106		
Connect			
Mechanic	88		
Connection			
Electrical system	95		
D			
Disposal	118		
E			
Environmental conditions	28		
F			
Fan cover	93		
Mounting	93		
Performance data	94		
Faults	113		
Features	21		
Feedback	84		
G			
General safety instructions	15		
H			
Holding brake	22		
I			
Installation position	83		
Instruction	10		
Intended use	25		
iTec connector			
Connection	100		
L			
Label, see Safety symbols	14		
M			
Maintenance	108		
		Intervals	110
		Motor	
		Commissioning	106
		Dismantling	117
		Disposal	118
		Electrical installation	95
		Mechanical installation	88
		Storage	79
		Transport	79
		N	
		Name plate	18
		O	
		Operating Conditions	28
		Ordering options	23
		Fan cover	23
		Feather key	23
		Holding brake	23
		Sealing air connection	24
		Output elements	
		Dismantling	92
		Mounting	90
		P	
		Pictograms	10
		Power box	95
		Turning	95
		Power derating	87
		Protection equipment	85
		Temperature sensor	85
		S	
		Safety	14
		De-energized and voltage-free condition	16
		Grounding	15
		Hot surfaces	16
		Intended use	25
		Keep the environment clean	15
		Moving or rotating components	16
		Overheating	16
		Protective equipment	15
		Safety pictograms	15
		Shut down and secure the machine or plant	15
		Tightening torques	15
		Safety symbols	14
		Scope of supply	78
		Security	
		General safety instructions	15
		Service	12
		Shaft end A	86
		Signal words	10
		speedtec connector	
		Connection	100
		Storage	79
		Support	12
		Symbols	10
		T	
		Target group	8
		Technical data	28

Index

terminal box	
Connection	102
Tightening torques	
Fan cover	93
Flange	88
Transport	79

More Information:
www.beckhoff.com/am8000

Beckhoff Automation GmbH & Co. KG
Hülshorstweg 20
33415 Verl
Germany
Phone: +49 5246 9630
info@beckhoff.com
www.beckhoff.com

