

# X20(c)DOF322

## 1 General information

The module is equipped with 16 outputs for 1-wire connections. The module is designed for source output wiring.

- 16 digital outputs
- Source connection
- 1-wire connections
- Integrated output protection

## 2 Coated modules

Coated modules are X20 modules with a protective coating for the electronics component. This coating protects X20c modules from condensation and corrosive gases.

The modules' electronics are fully compatible with the corresponding X20 modules.

**For simplification purposes, only images and module IDs of uncoated modules are used in this data sheet.**

The coating has been certified according to the following standards:

- Condensation: BMW GS 95011-4, 2x 1 cycle
- Corrosive gas: EN 60068-2-60, method 4, exposure 21 days



## 3 Order data

Model number	Short description	Figure
	<b>Digital outputs</b>	
X20DOF322	X20 digital output module, 16 output, 24 VDC, 0.5 A, source, 1-wire connections	
X20cDOF322	X20 digital output module, coated, 16 output, 24 VDC, 0.5 A, source, 1-wire connections	
	<b>Required accessories</b>	
	<b>Bus modules</b>	
X20BM11	X20 bus module, 24 VDC keyed, internal I/O supply continuous	
X20BM15	X20 bus module, with node number switch, 24 VDC keyed, internal I/O supply continuous	
X20cBM11	X20 bus module, coated, 24 VDC keyed, internal I/O supply continuous	
	<b>Terminal blocks</b>	
X20TB1F	X20 terminal block, 16-pin, 24 VDC keyed	

Table 1: X20DOF322, X20cDOF322 - Order data

## 4 Technical data

Model number	X20DOF322	X20cDOF322
<b>Short description</b>		
I/O module	16 digital outputs 24 VDC for 1-wire connections	
<b>General information</b>		
B&R ID code	0xC0EA	0xDD4C
Status indicators	I/O function per channel, operating state, module status	
Diagnostics		
Module run/error	Yes, using status LED and software	
Outputs	Yes, using status LED and software (output error status)	
Power consumption		
Bus	0.28 W	
Internal I/O	0.95 W	
Additional power dissipation caused by actuators (resistive) [W] <sup>1)</sup>	+0.56 W	
Certifications		
CE	Yes	
KC	Yes	-
EAC	Yes	
UL	cULus E115267 Industrial control equipment	
HazLoc	cCSAus 244665 Process control equipment for hazardous locations Class I, Division 2, Groups ABCD, T5	
ATEX	Zone 2, II 3G Ex nA nC IIA T5 Gc IP20, Ta (see X20 user's manual) FTZÜ 09 ATEX 0083X	
DNV GL	Temperature: <b>B</b> (0 - 55°C) Humidity: <b>B</b> (up to 100%) Vibration: <b>B</b> (4 g) EMC: <b>B</b> (bridge and open deck)	
LR	ENV1	-
KR	Yes	
<b>Digital outputs</b>		
Variant	FET positive switching	
Nominal voltage	24 VDC	
Switching voltage	24 VDC -15% / +20%	
Nominal output current	0.5 A	
Total nominal current	8 A	
Connection type	1-wire connections	
Output circuit	Source	
Output protection	Thermal cutoff on overcurrent or short circuit (see value "Peak short circuit current") Internal freewheeling diode for switching inductive loads (see section "Switching inductive loads")	
Diagnostic status	Output monitoring with 10 ms delay	
Leakage current when switched off	5 µA	
R <sub>DS(on)</sub>	140 mΩ	
Peak short-circuit current	<3 A	
Switch-on in the event of overload shutdown or short-circuit shutdown	Approx. 10 ms (depends on the module temperature)	
Switching delay <sup>2)</sup>		
0 → 1	<300 µs	
1 → 0	<300 µs	
Switching frequency		
Resistive load <sup>2)</sup>	Max. 500 Hz	
Inductive load	See section "Switching inductive loads"	
Braking voltage when switching off inductive loads	Typ. 45 VDC	
Isolation voltage between channel and bus	500 V <sub>eff</sub>	
<b>Electrical properties</b>		
Electrical isolation	Channel isolated from bus Channel not isolated from channel	
<b>Operating conditions</b>		
Mounting orientation		
Horizontal	Yes	
Vertical	Yes	
Installation elevation above sea level		
0 to 2000 m	No limitation	
>2000 m	Reduction of ambient temperature by 0.5°C per 100 m	
Degree of protection per EN 60529	IP20	

Table 2: X20DOF322, X20cDOF322 - Technical data

Model number	X20DOF322	X20cDOF322
<b>Ambient conditions</b>		
Temperature		
Operation		
Horizontal mounting orientation	-25 to 60°C	
Vertical mounting orientation	-25 to 50°C	
Derating	See section "Derating"	
Storage	-40 to 85°C	
Transport	-40 to 85°C	
Relative humidity		
Operation	5 to 95%, non-condensing	Up to 100%, condensing
Storage	5 to 95%, non-condensing	
Transport	5 to 95%, non-condensing	
<b>Mechanical properties</b>		
Note	Order 1x terminal block X20TB1F separately Order 1x bus module X20BM11 separately	Order 1x terminal block X20cTB1F separately Order 1x bus module X20cBM11 separately
Spacing	12.5 <sup>+0.2</sup> mm	

Table 2: X20DOF322, X20cDOF322 - Technical data

- 1) Number of outputs x  $R_{DS(on)}$  x Nominal output current<sup>2</sup>. For a calculation example, see section "Mechanical and electrical configuration" of the X20 system user's manual.
- 2) At loads  $\leq 1$  k $\Omega$ .

## 5 Status LEDs

For a description of the various operating modes, see section "Additional information - Diagnostic LEDs" of the X20 system user's manual.

Figure	LED	Color	Status	Description
	S	Green	Off	Module supply not connected
			Single flash	RESET mode
			Blinking	PREOPERATIONAL mode
			On	RUN mode
		Red	Off	Module supply not connected or everything OK
			Single flash	Warning/Error on an I/O channel. Level monitoring for digital outputs has been triggered.
		Red on / Green single flash	Invalid firmware	
1 - 16	Orange		Output status of the corresponding digital output	

## 6 Pinout

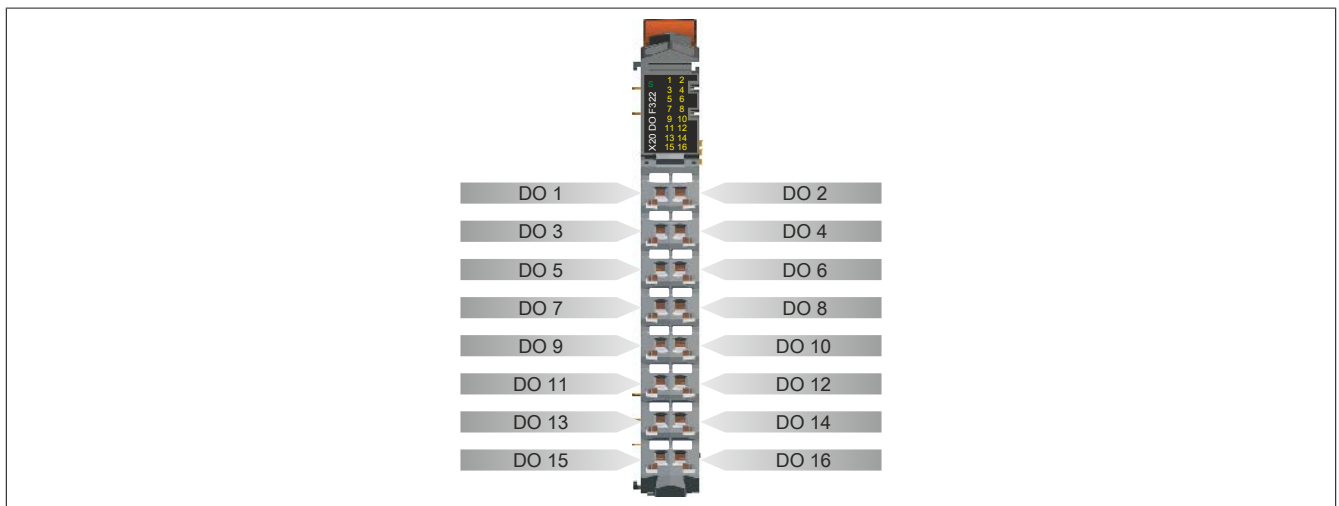

## 7 Connection example

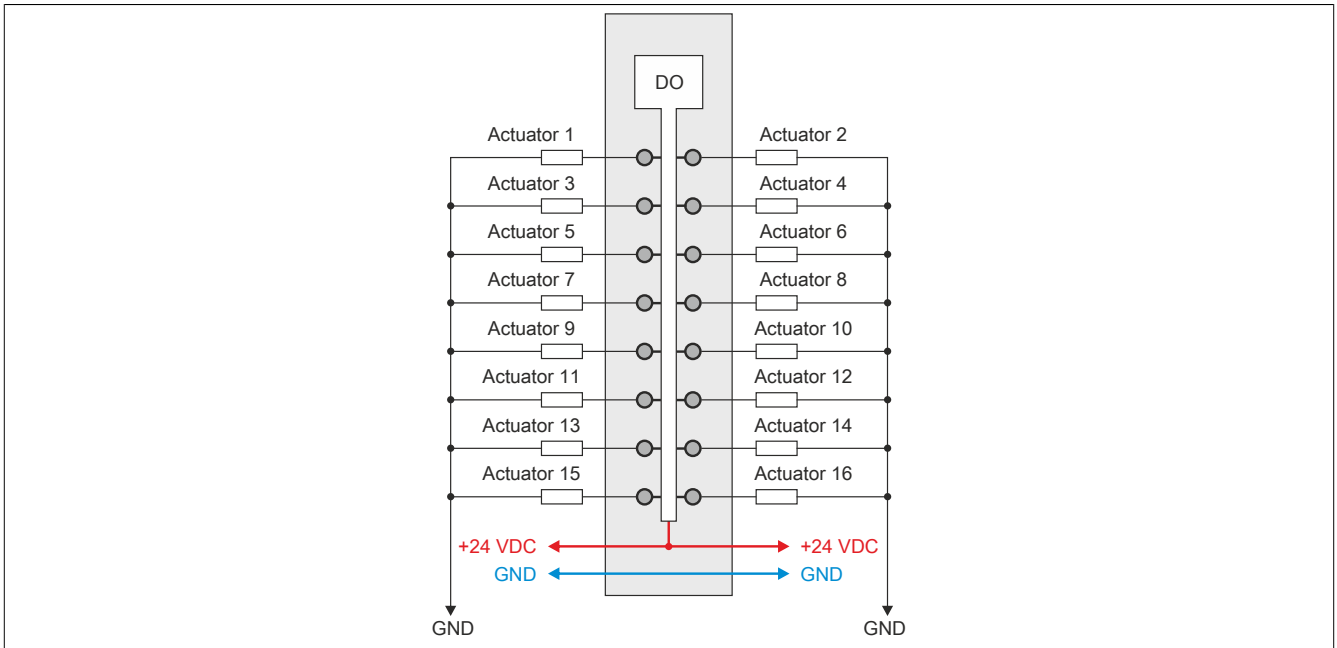

### Caution!

If the module is operated outside of specifications, the output current can increase above the maximum permissible nominal current. This applies to individual channels and also to the summation current for the module.

Therefore sufficient cable cross sections or external safety measures must be used.

## 8 Output circuit diagram

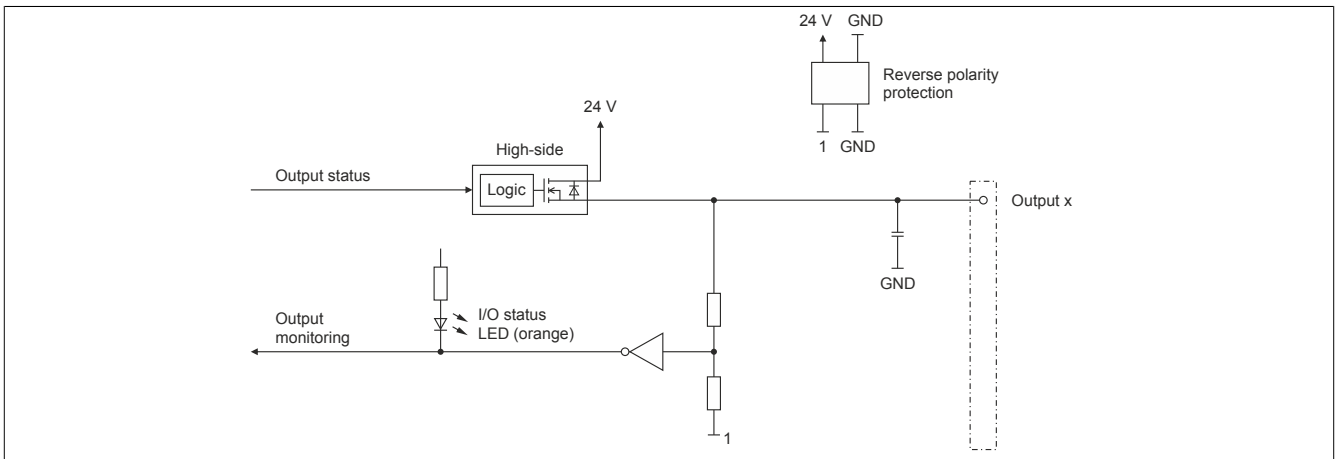

## 9 Derating

There is no derating when operated below 55°C.

When operating above 55°C, the maximum current per channel is reduced to 0.35 A!

## 10 Switching inductive loads

Environmental temperature: 55°C, all outputs with the same load

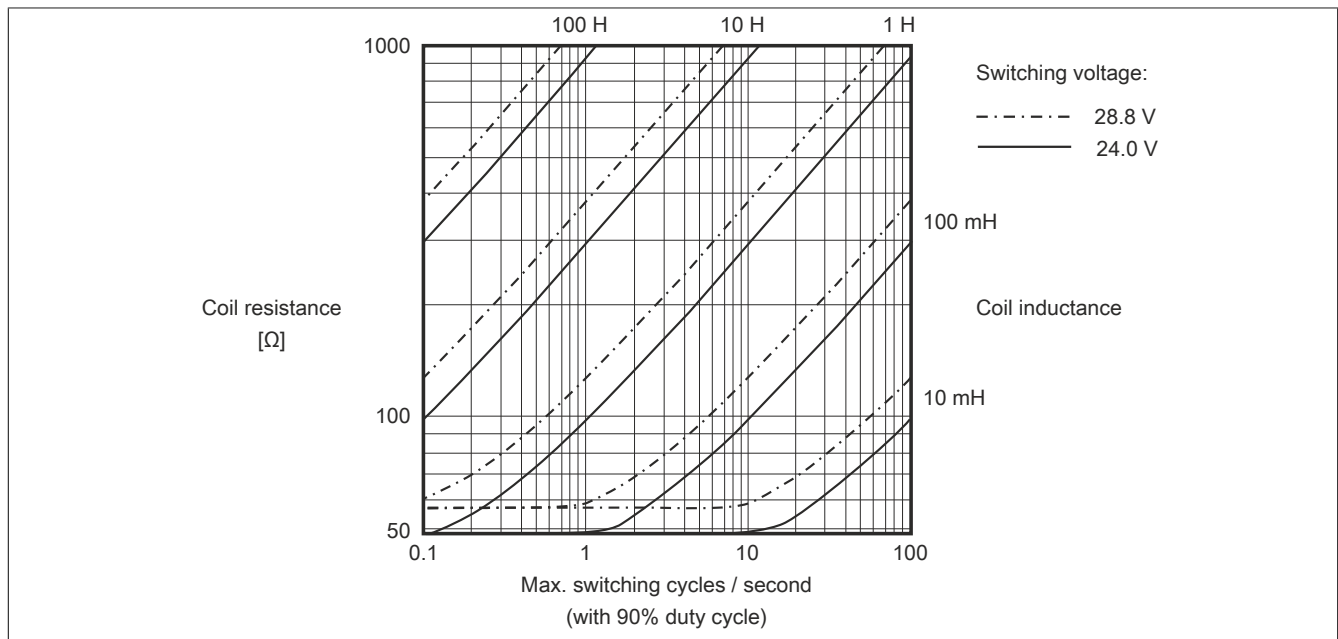

Environmental temperature: 60°C, all outputs with the same load

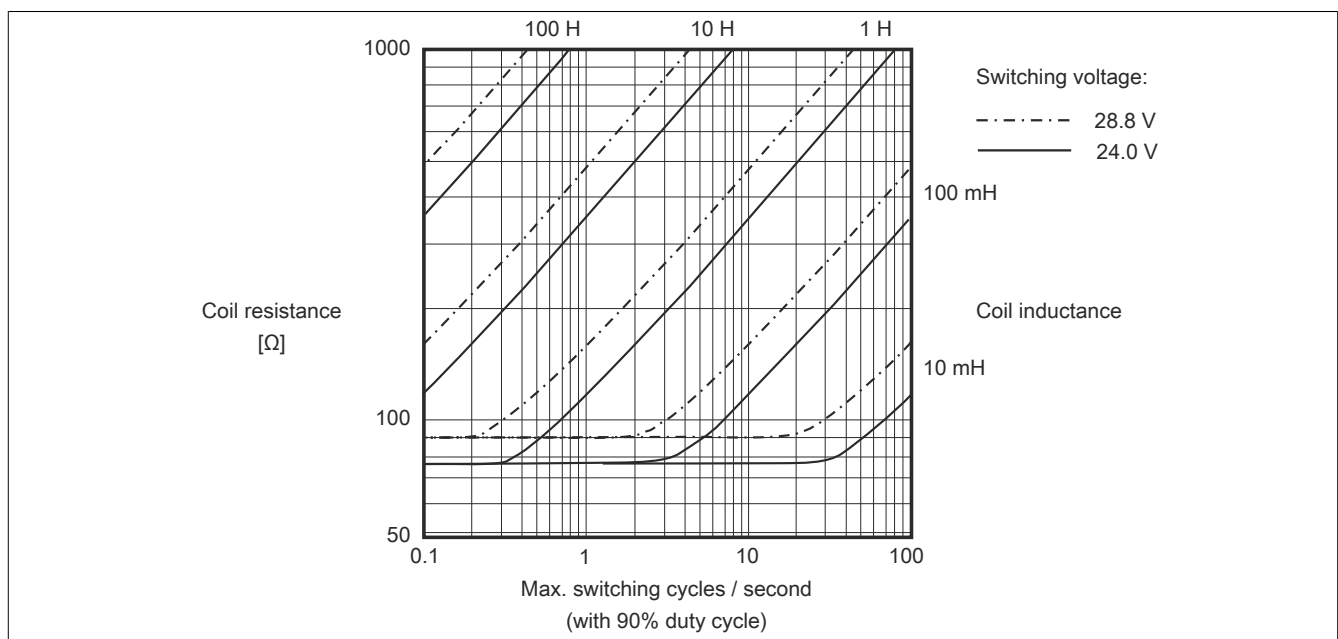

### Information:

If the maximum number of operating cycles per second is exceeded, an external inverse diode must be used.

Operating conditions outside of the area in the diagram are not permitted!

## 11 Register description

### 11.1 General data points

In addition to the registers described in the register description, the module has additional general data points. These are not module-specific but contain general information such as serial number and hardware variant.

General data points are described in section "Additional information - General data points" of the X20 system user's manual.

### 11.2 Function model 0 - Standard

Register	Fixed offset	Name	Data type	Read		Write	
				Cyclic	Acyclic	Cyclic	Acyclic
2	0	DigitalOutput	UINT			•	
		Switching state of digital outputs 1 to 8	USINT				
		DigitalOutput01	Bit 0				
		...	...				
3	1	DigitalOutput08	Bit 7				
		Switching state of digital outputs 9 to 16	USINT				
		DigitalOutput09	Bit 0				
		...	...				
30	2	DigitalOutput16	Bit 7				
		StatusDigitalOutput	UINT		•		
		Status of digital outputs 1 to 8	USINT				
		StatusDigitalOutput01	Bit 0				
31	3	...	...				
		StatusDigitalOutput08	Bit 7				
		Status of digital outputs 9 to 16	USINT				
		StatusDigitalOutput09	Bit 0				
		...	...				
		StatusDigitalOutput16	Bit 7				

Fixed modules require their data points to be in a specific order in the X2X frame. Cyclic access occurs according to a predefined offset, not based on the register address.

Acyclic access continues to be based on the register numbers.

### 11.3 Function model 254 - Bus Controller

Register	Offset <sup>1)</sup>	Name	Data type	Read		Write	
				Cyclic	Acyclic	Cyclic	Acyclic
2	0	Switching state of digital outputs 1 to 8	USINT			•	
		DigitalOutput01	Bit 0				
		...	...				
		DigitalOutput08	Bit 7				
3	1	DigitalOutput16	Bit 7				
		Switching state of digital outputs 9 to 16	USINT				
		DigitalOutput09	Bit 0				
		...	...				
30	-	DigitalOutput16	Bit 7				
		Status of digital outputs 1 to 8	USINT		•		
		StatusDigitalOutput01	Bit 0				
		...	...				
31	-	StatusDigitalOutput08	Bit 7				
		Status of digital outputs 9 to 16	USINT				
		StatusDigitalOutput09	Bit 0				
		...	...				
		StatusDigitalOutput16	Bit 7				

1) The offset specifies where the register is within the CAN object.

#### 11.3.1 Using the module on the bus controller

Function model 254 "Bus controller" is used by default only by non-configurable bus controllers. All other bus controllers can use additional registers and functions depending on the fieldbus used.

For detailed information, see section "Additional information - Using I/O modules on the bus controller" of the X20 user's manual (version 3.50 or later).

#### 11.3.2 CAN I/O bus controller

The module occupies 2 digital logical slots on CAN I/O.

## 11.4 Digital outputs

The output status is transferred to the output channels with a fixed offset (<60 µs) based on the network cycle (SyncOut).

### 11.4.1 Switching state of digital outputs 1 to 16

Name:

DigitalOutput

DigitalOutput01 to DigitalOutput16

The switching state of digital outputs 1 to 16 are stored in this register.

Function model 0 - Standard only:

The "Packed outputs" setting in the Automation Studio I/O configuration is used to determine whether all of these registers' bits should be set up individually as data points in the Automation Studio I/O mapping ("DigitalOutput01" through "DigitalOutput16") or whether these registers should be displayed as an individual UINT data point ("DigitalOutput").

Data type	Values	Value
UINT	0 to 65535	Packed outputs = on
USINT	See bit structure	Packed outputs = Off or function model ≠ 0 - Standard.

Bit structure:

#### Register 2, Offset 0:

Bit	Name	Value	Information
0	DigitalOutput01	0	Digital output 01 reset
		1	Digital output 01 set
...		...	
7	DigitalOutput08	0	Digital output 08 reset
		1	Digital output 08 set

#### Register 3, Offset 1:

Bit	Name	Value	Information
0	DigitalOutput09	0	Digital output 09 reset
		1	Digital output 09 set
...		...	
7	DigitalOutput16	0	Digital output 16 reset
		1	Digital output 16 set

## 11.5 Monitoring status of the digital outputs

On the module, the output states of the outputs are compared to the target states. The control of the output driver is used for the target state.

A change in the output state resets monitoring for that output. The status of each individual channel can be read. A change in the monitoring status generates an error message.

### 11.5.1 Status of digital outputs 1 to 16

Name:

StatusDigitalOutput

StatusDigitalOutput01 to StatusDigitalOutput16

The status of digital outputs 1 to 16 is mapped in this register.

Function model 0 - Standard only:

The "packed outputs" setting in the Automation Studio I/O configuration is used to determine whether all of these registers' bits should be set up individually as data points in the Automation Studio I/O mapping ("StatusDigitalOutput01" through "StatusDigitalOutput16") or whether these registers should be displayed as an individual UINT data point ("StatusDigitalOutput").

Data type	Values	
UINT	0 to 65535	Packed outputs = on
USINT	See the bit structure.	Packed outputs = Off or function model ≠ 0 - Standard.

Bit structure:

#### Register 30, Offset 1:

Bit	Name	Value	Description
0	StatusDigitalOutput01	0	Channel 01: No error
		1	Channel 01: <ul style="list-style-type: none"> <li>Short circuit or overload</li> <li>Channel switched on and missing I/O power supply</li> <li>Channel switched off and external voltage applied on channel</li> </ul>
...		...	
7	StatusDigitalOutput08	0	Channel 08: No error
		1	Channel 08: For error description, see channel 01

#### Register 31, Offset 2:

Bit	Name	Value	Information
0	StatusDigitalOutput09	0	Channel 09: No error
		1	Channel 09: <ul style="list-style-type: none"> <li>Short circuit or overload</li> <li>Channel switched on and missing I/O power supply</li> <li>Channel switched off and external voltage applied on channel</li> </ul>
...		...	
7	StatusDigitalOutput16	0	Channel 16: No error
		1	Channel 16: For error description, see channel 09

### 11.6 Minimum cycle time

The minimum cycle time specifies the time up to which the bus cycle can be reduced without communication errors occurring. It is important to note that very fast cycles reduce the idle time available for handling monitoring, diagnostics and acyclic commands.

Minimum cycle time
100 µs

### 11.7 Minimum I/O update time

The minimum I/O update time specifies how far the bus cycle can be reduced so that an I/O update is performed in each cycle.

Minimum I/O update time
Equal to the minimum cycle time