

Installation Instructions

Original Instructions



Allen-Bradley

by ROCKWELL AUTOMATION



Magnetically Coded Non-contact Interlock Switch (MC2)

Catalog Numbers 440N-Z21W1PA, 440N-Z21W1PB, 440N-Z21W1PH

IMPORTANT Save these instructions for future reference.

Summary of Changes

This publication contains the following new or updated information. This list includes substantive updates only and is not intended to reflect all changes.

Topic	Page
Updated Specifications	1
Updated Figure 2	2
Updated Declaration of Conformity	3

Introduction

Installation must be in accordance with the following instructions and specifications and implemented by suitable competent personnel. Adherence to the recommended maintenance instructions forms part of the warranty.

Do not use this unit as a mechanical stop. Guard stops and guides must be fitted.

This device is intended to be part of the safety-related control system of a machine. Before installation, perform a risk assessment to determine whether the specifications of this device are suitable for all foreseeable operational and environmental characteristics. See [Specifications](#) for certification information and ratings.



ATTENTION: The presence of spare actuators compromise the integrity of the safety systems. Personal injury or death, property damage, or economic loss can result. Use appropriate management controls, working procedures, and alternative protective measures to control their use and availability.



WARNING: Do not defeat, tamper, remove, or bypass this unit. These actions can result in severe injury to personnel.

Specifications

Attribute	Value
Safety standards	ISO 14119, IEC 60947-5-3, ISO 13849-1 (when used with approved safety relay)
Safety classification	Dual contacts suitable for Cat. 3 or 4 systems
Functional safety data ⁽¹⁾	<ul style="list-style-type: none">B10d: > 2 x 10⁶ operations minT1 proof test interval: 20 years Dual-channel interlock is suitable for performance levels PLe or PLd (according to ISO 13849-1).
Certifications	CE Marked for all applicable EU directives, UKCA Marked for relevant Statutory Instruments, cULus Listed, TÜV Certified

Operating Characteristics (at rated temperature range)

Make, min	
Sensing distance horizontal plane of operation	10 mm (0.39 in.)
Sensing distance vertical plane of operation	6 mm (0.23 in.)
Typical misalignment	± 4 mm (0.16 in.) (see Figure 3 on page 2 for misalignment curve)
Operational current	≤ 30 mA + 1 aux
Number of switches, max (connected in series)	Monitoring relay unit dependent
Operating voltage	24V DC +10% / -15% Class 2

Physical Characteristics

Case material	Molded ABS
Actuator material	Molded ABS
Color	Red

Outputs

Safety output (solid-state relay)	2 x N.C. 50 mA
Auxiliary	1 x PNP N.O. 200 mA

Responsetime

Switch response time	5 ms
Series response time	5 ms
Maximum frequency of operation	1 Hz

Environmental

Operating temperature	-10...+55 °C (14...131 °F)
Operating humidity	5...95% relative
Washdown rating / enclosure type rating	IEC 60529, IP69
Shock and vibration	IEC 680068-2-27 30 g, 11 ms IEC 680068-2-6 10...55 Hz
E.M.C.	EN 61000-6-2, EN 60947-5-3

Protection

Safety output short-circuit protection	Provided by the approved safety relays
Auxiliary overload protection	Internal resettable fuse
24V supply reverse polarity protection	Incorporated
Electrical life	1 x 10 ⁶ cycles

(1) Usable for ISO 13849-1. Data other than B10d is based on the usage rate of 10p/10 minutes, 24 hrs per day, 360 days per year, representing 51,840 operations per year.

Approximate Dimensions

Figure 1 - Unit Dimensions [mm (in.)]

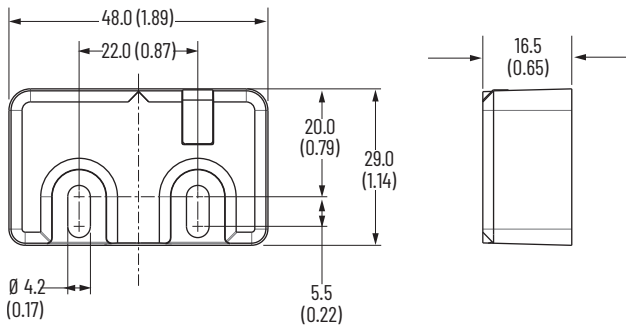
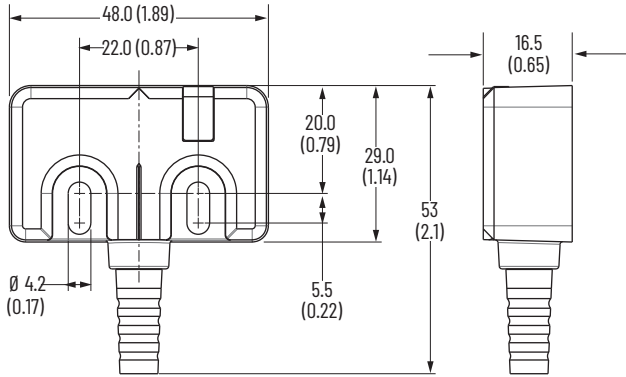

Mounting Information

Use nonremovable screws, bolts, or nuts to mount the switch and actuator. Do not over torque the mounting hardware. We recommend M3 screws and washers throughout.

Maximum torque is 1 N•m (8.86 in•lb). Use nonmagnetic mounting hardware.

Position the switch and actuator so they align with each other.

Mounting for Maximum Misalignment

Mount the sensor to the fixed part of the guard and the actuator to the movable section. Keep the sensor and actuator within the sensing range, see [Figure 3](#).

Minimum distance between sensors is 50 mm (1.97 in.).

IMPORTANT To obtain the maximum switching distance, center the switches ± 4 mm (0.24 in.). See [Figure 2](#).

Figure 2 - Sensor Alignment

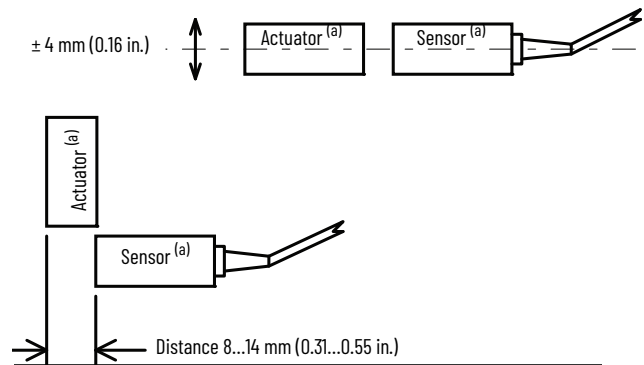

(a) Help prevent damage, maintain a 2 mm (0.08 in.) gap between the actuator and sensor.

Figure 3 - Misalignment Curve [mm (in.)]

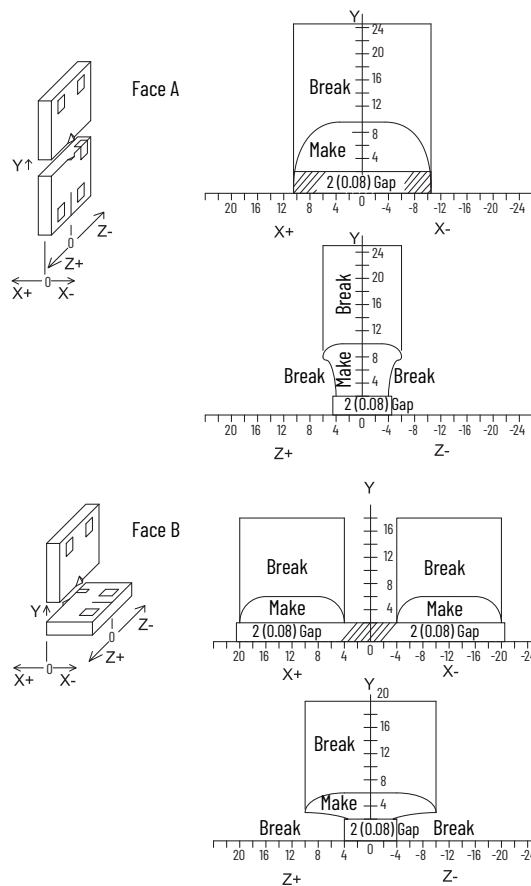

Status Indicator Operation and Diagnostics

Table 1 - Device Output Status Indicators (per IEC 60073)

State	Status	Troubleshooting
Off	Not powered	Check the supply, check wiring to controller A
Off	Overload	Check the aux connections
Red	Actuator not present	If the actuator is present, check misalignment.
Green	Actuator present	—
Green flashing	Actuator present Actuation not present on other switches or wiring fault	Check wiring to the controller. Check the actuators on the other switches

Connection Information

Table 2 - Wiring Diagram

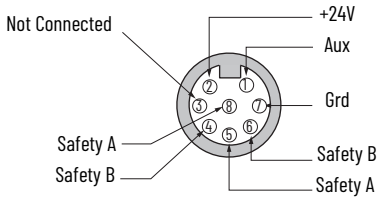

Pin	Wire Color	Signal
1	White	PNP aux
2	Brown	+24V
3	Green	Not connected
4	Yellow	Safety B
5	Gray	Safety A
6	Pink	Safety B
7	Blue	0V
8	Red	Safety A

Recommended Mating Cable

The standard cable lengths are 2 m (6.5 ft), 5 m (16.4 ft), and 10 m (32.8 ft). Use catalog number 889D-F8AB-2 [2 m (6.5 ft)] for the standard length, or replace the 2 with 5 for 5 m (16.4 ft), or 10 for 10 m (32.8 ft).

IMPORTANT When you use the MC2 interlock switch with any MSR100 series relay, the red and gray wires (Safety A) must connect to S11 and S12 for the diagnostic function to operate correctly.

Power Supply Requirements

A power supply that complies with IEC/EN 60204 and IEC/EN 61558-1 must supply 24V DC $\pm 10\%$ /-15%. Such a power supply meets the electrical safety requirements and maintains the minimum power of 20.4V DC during 20 ms, even if voltage dips.

When you use an approved relay with an MC2 interlock switch and the same power supply for all devices, the relay provides surge protection for the MC2 interlock switch. Extra protection is required if you use a separate power supply for the MC2 interlock switch.

Safety Ratings

An MC2 interlock switch can achieve up to Cat 4/PLe, SIL CL 3 when individually monitored by an approved monitoring relay unit that itself achieves Cat 4/PLe SIL CL 3.

Two or more MC2 interlock switches connected in series with an approved relay achieves up to CAT3/PLd/SIL CL2.

Maintenance

Every 6 months, check the correct operation of the switching circuit. Also check for signs of abuse or tampering. Inspect the switch casing for damage.

Repair

If there is any malfunction or damage, do not attempt to repair. You must replace the unit before you allow machine operation.

Declaration of Conformity

CE Conformity

Rockwell Automation declares that the products that are shown in this document conform with the 2014/30/EU Electromagnetic Compatibility Directive (EMC) and 2006/42/EC Machinery Directive (MD) and that the respective standards and/or technical specifications have been applied.

For a comprehensive CE certificate visit: rok.auto/certifications

UKCA Conformity

Rockwell Automation declares that the products that are shown in this document are in compliance with 2016 No. 1091 Electromagnetic Compatibility Regulations and 2008 No. 1597 Supply of Machinery (Safety) Regulations and that the respective standards and/or technical specifications have been applied.

For a comprehensive UKCA certificate visit: rok.auto/certifications

Approved Monitoring Relay Units

Only use MC2 interlock switches with the approved relays. Use of other devices that are not listed is at your own risk.

Only 24V DC MSR safety relays or MSR safety relays that are configured for 24V DC operation are compatible with MC2 interlock switches.

Table 3 - Monitoring Relay Units/Max Number of Series MC2 Interlock Switches

Monitoring Relay Series	Cat. No.	Max MC2 Units in Series 24V DC Supply Voltage		
		-5%	-10%	-15%
GSR Series				
GSR CI	440R-S13R2	8	10	10
GSR DI	440R-D22R2	8	10	10
GSR SI	440R-S12R2	8	10	10
GSR DIS	440R-D22S2	8	10	10
CR30	440C-CR30	8	10	10
MSR Series				
MSR30RT/RTP	440R-N23197/440R-N23198	10	10	10
MSR 100 Series				
MSR124RT	440R-G23110/440R-G23108/ 440R-G23107	10	10	10
MSR126T/R	440R-N23117/440R-N23123	10	10	10
MSR126.1T/.1R	440R-N23114/440R-N23120	10	10	10
MSR127T/TP	440R-N23126/440R-N23132	10	10	10
MSR127R/RP	440R-N23129/440R-N23135	10	10	10
MSR131RTP	440R-C23139	10	10	10
MSR138DP	440R-M23151	10	10	10
MSR138.1DP	440R-M23084	10	10	10
MSR142RTP	440R-G23216	10	8	-
MSR178DP	440R-M23227	10	10	10

IMPORTANT For up-to-date information, visit <https://www.rockwellautomation.com/en-us/products/hardware/allen-bradley/safety-products/safety-sensors/safety-interlock-switches/non-contact-interlock-switches/440n-magnetically-coded.html>

Troubleshooting

Figure 4 - Series Circuit - Two Guards Open

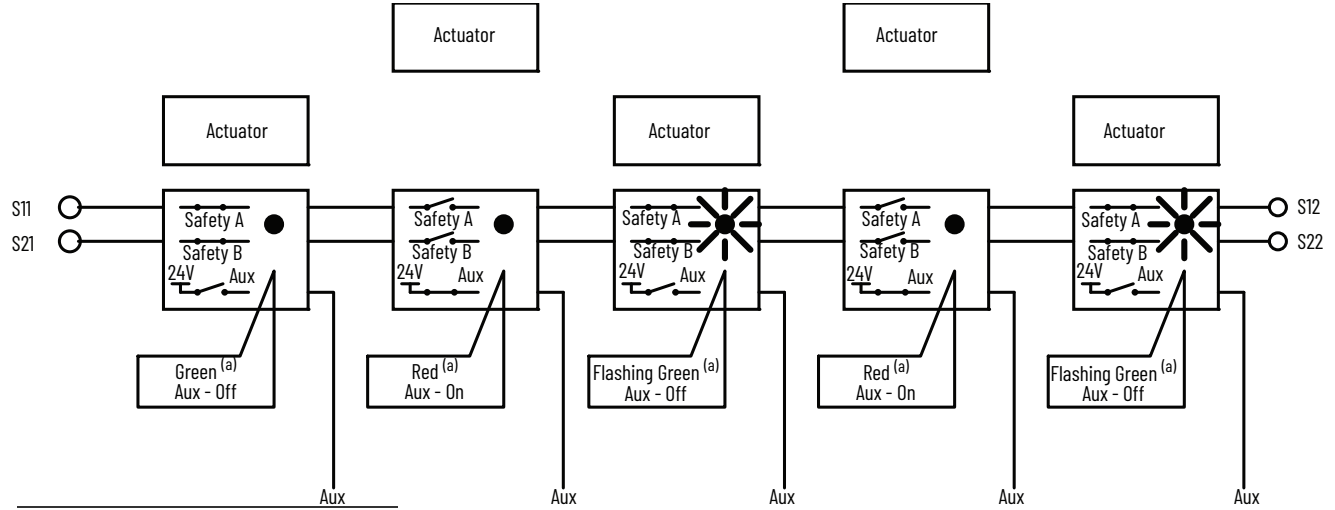

(a) Status indicator

The auxiliary contacts close simultaneously as the first safety contact opens.

Figure 5 - Series Circuit - Open Circuit on Channel A

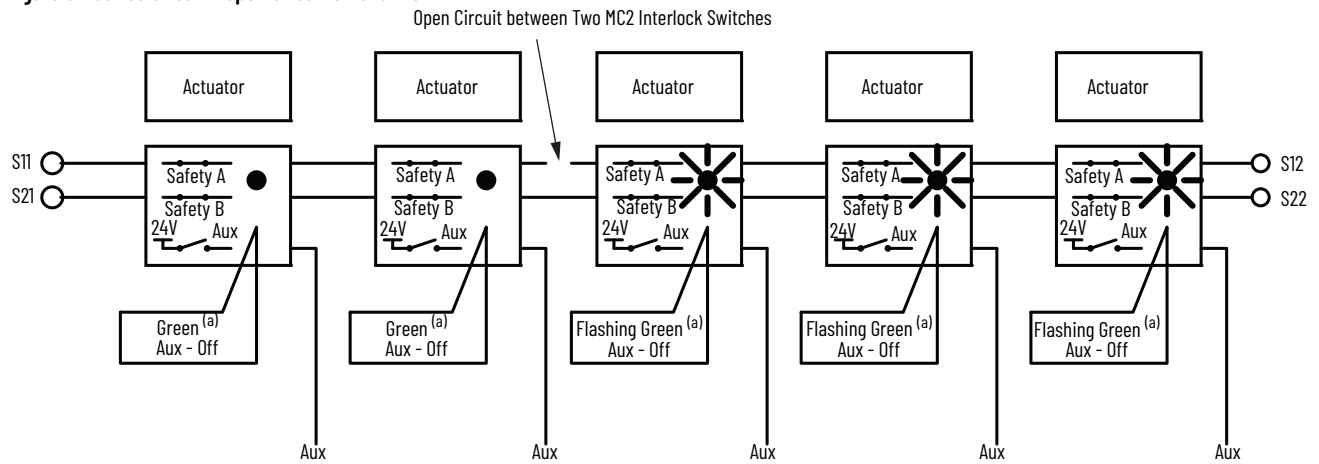

(a) Status indicator

The auxiliary contacts close simultaneously as the first safety contact opens.

Application Wiring Examples

Figure 6 - Single Switch, Automatic Reset, Monitored Outputs MSR127TP Safety Relay

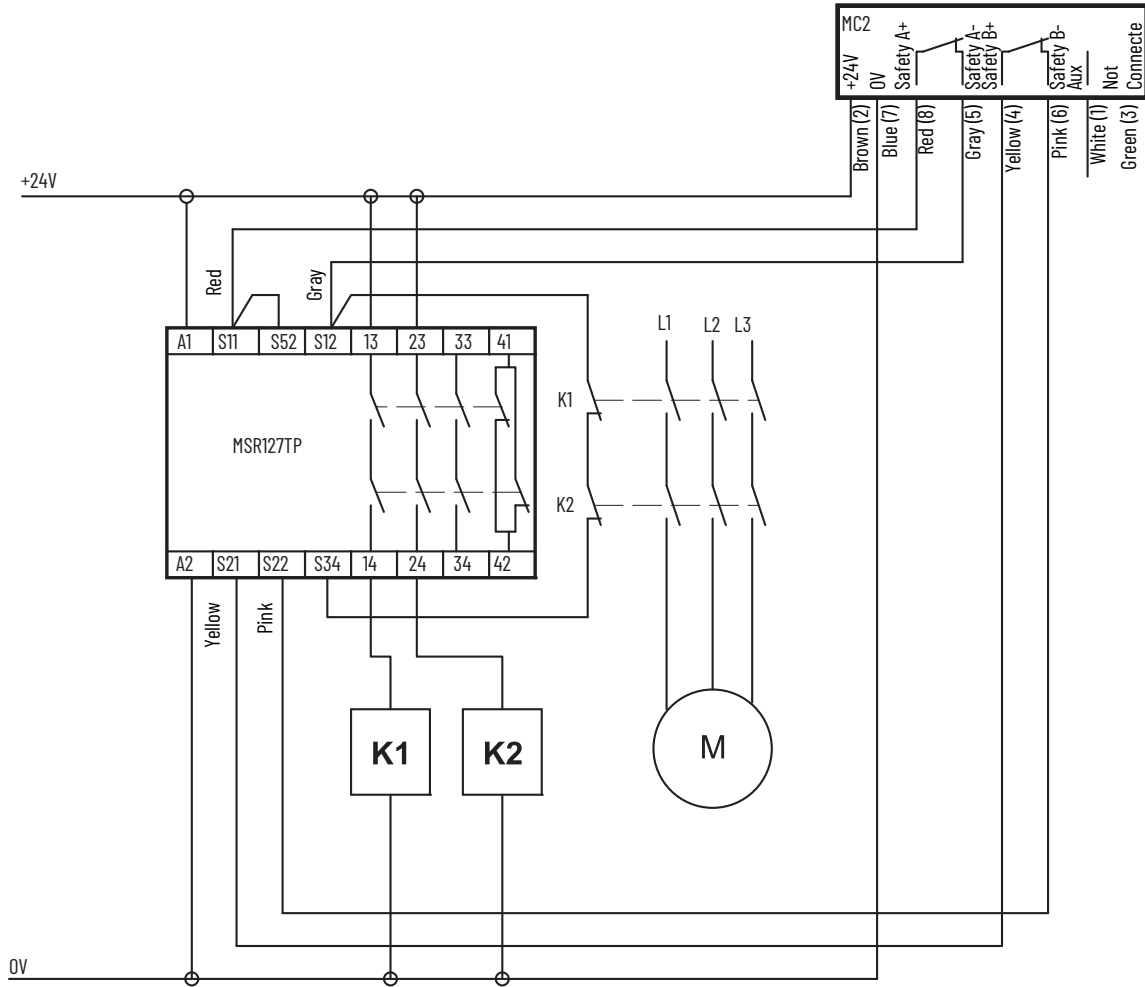

IMPORTANT To maintain the correct diagnostic operation, the red wire (QD pin 8) must connect to S11.

Figure 7 - Multiple Switches, Automatic Reset, Monitored Output MSRI27TP Safety Relay

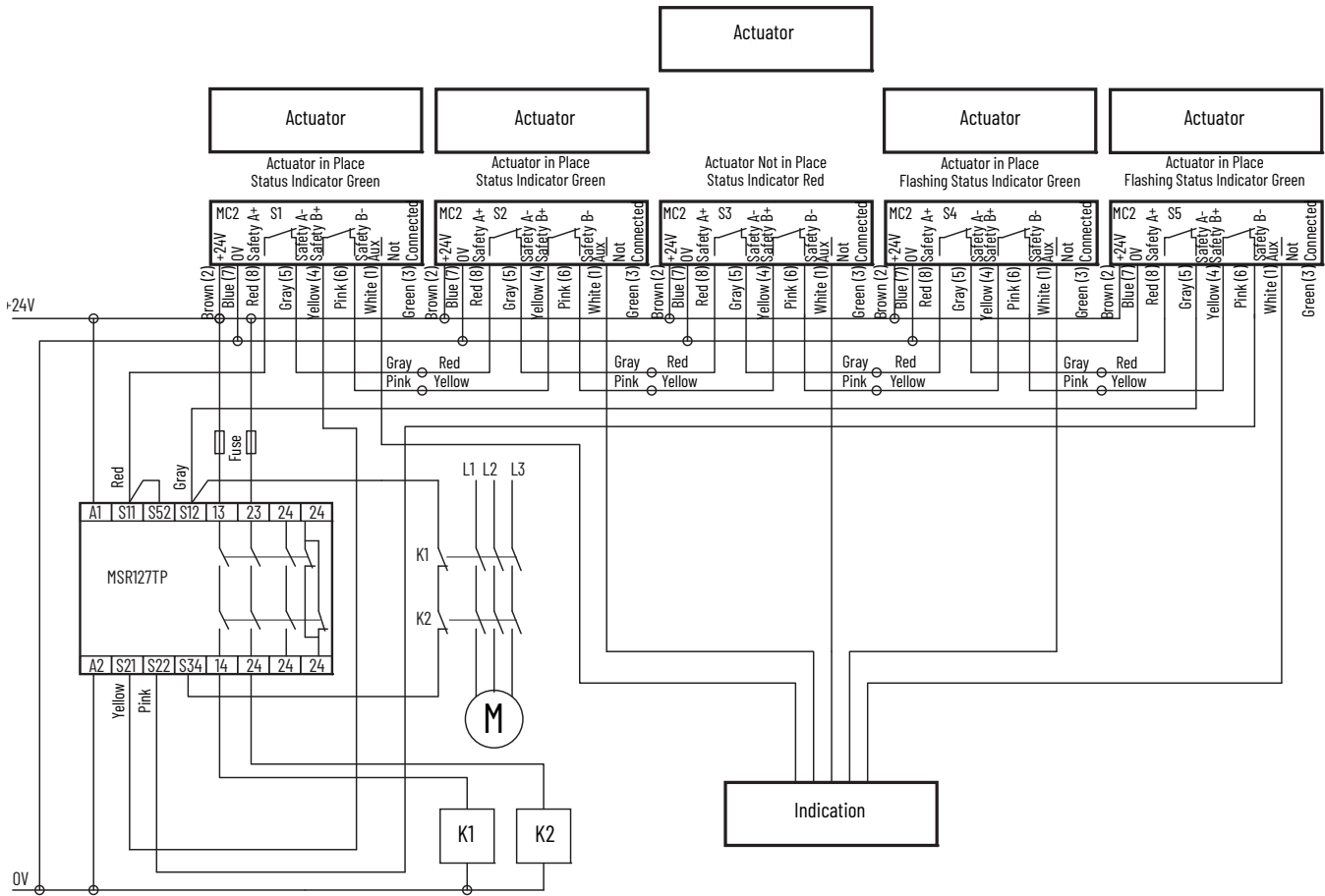

Waste Electrical and Electronic Equipment (WEEE)







At the end of life, this equipment should be collected separately from any unsorted municipal waste.

Rockwell Automation maintains current product environmental compliance information on its website at rok.auto/pec.

Your comments help us serve your documentation needs better. If you have any suggestions on how to improve our content, complete the form at rok.auto/docfeedback. For technical support, visit rok.auto/support.

Rockwell Otomasyon Ticaret A.Ş. Kar Plaza İş Merkezi E Blok Kat:6 34752 İçerenköy, İstanbul, Tel: +90 (216) 5698400 EEE Yönetmeliğine Uygundur

Connect with us.    

rockwellautomation.com — expanding **human possibility**[®]

AMERICAS: Rockwell Automation, 1201 South Second Street, Milwaukee, WI 53204-2496 USA, Tel: (1) 414.382.2000

EUROPE/MIDDLE EAST/AFRICA: Rockwell Automation NV, Pegasus Park, De Kleetlaan 12a, 1831 Diegem, Belgium, Tel: (32) 2663 0600

ASIA PACIFIC: Rockwell Automation SEA Pte Ltd, 2 Corporation Road, #04-05, Main Lobby, Corporation Place, Singapore 618494, Tel: (65) 6510 6608

UNITED KINGDOM: Rockwell Automation Ltd., Pitfield, Kiln Farm, Milton Keynes, MK11 3DR, United Kingdom, Tel: (44)(1908) 838-800

Allen-Bradley, expanding human possibility, Guardmaster, and Rockwell Automation are trademarks of Rockwell Automation, Inc. Trademarks not belonging to Rockwell Automation are property of their respective companies.

Publication 440N-IN003C-EN-P - July 2024 | Supersedes Publication 440N-IN003B-EN-P - April 2018
Copyright © 2024 Rockwell Automation, Inc. All rights reserved. Printed in the U.S.A.