

Complete UL/CSA Disconnect Switch Kits

Includes disconnect switch, operating handle with defeater mechanism and operating shaft, NFPA handle, auxiliary contacts, and padlock attachment.

Catalog Number Explanation

Fourth pole (20...63 A), additional auxiliary contacts, and handle options available in accessory section.

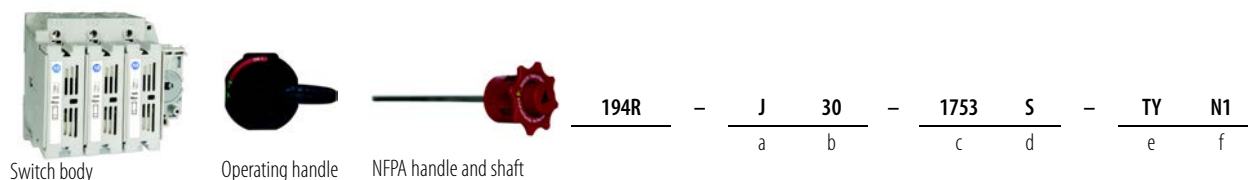

a	
Fuse Type	
Code	Description
C	UL Class CC, CSA Type HRCI-MISC
J	UL Class J, CSA Type HRCI-J
H	CSA Type HRCII-C
B	BS88 ⁽¹⁾
D	DIN ⁽¹⁾
F	NFC ⁽¹⁾
N	Non-fused (20...63 A) ⁽³⁾

b		
Load Size ⁽¹⁾		
Code	Description	Dimensional Ref. ⁽²⁾
20	20 A (BS88)	A1
25	25 A (NFC)	A1
30	30 A (CC, J, HRCI-J)	A1
	30 A (Non-Fused) ⁽³⁾	A2
32	30 A (HRCII-C)	B1
	32 A (BS88, NFC)	A1
60	32 A (DIN)	B1
	60 A (J, HRCI-J, HRCII-C)	B1
63	60 A (Non-Fused) ⁽³⁾	B2
	63 A (BS88, DIN, NFC)	B1

c	
No. of Poles	
Code	Description
1753	3-poleswitch

- (1) Fuse classes BS88, DIN, and NFC are not suitable for use in North American applications
- (2) See [page 33](#) for dimensional reference data.
- (3) Non-fused disconnect switches must use separately installed fuses for upstream short-circuit protection



d	
Fuse Indication	
Code	Description
blank	No fuse status indication
S ⁽¹⁾	Fuse status indication

e	
External Handle	
Code	Description
PY	Std/pistol red/yellow handle, 4/4X, IP66 (Cat. No. 194R-PY)
PB	Std/pistol black handle, 4/4X, IP66 (Cat. No. 194R-PB)
TY	Test mode red/yellow handle, 4/4X, IP66 (Cat. No. 194R-PYT)
TB	Test mode black handle, 4/4X, IP66 (Cat. No. 194R-PBT)

f	
Shaft and NFPA 79 Handle	
Code	Description
S1	Cat. No. 194R-S1 shaft (12 in.)
S2	Cat. No. 194R-S2 shaft (21 in.)
N1	NFPA79 handle with 12 in. shaft and guard tube
N2	NFPA79 handle with 21 in. shaft and guard tube

(1) Class C and J fuses only

Bulletin 194R Overview

	 <p>Bulletin 194R-C, J, H, B, D, F, L, N, NU</p>	 <p>Bulletin 194R-NE</p>
Product Type	Fused and non-fused rotary disconnect switches	Non-fused IEC rotary disconnect switches
Current Range	20...1200 A	100...1250 A
Main Applications	<ul style="list-style-type: none"> UL 98 ratings "suitable as service entrance disconnecting means" UL 508, CSA ratings "suitable as at-motor disconnect" UL and IEC applications 	<ul style="list-style-type: none"> Disconnecting means IEC applications
Functionality	<ul style="list-style-type: none"> 3- or 4-pole fusible or non-fusible disconnect for standard OFF-ON or emergency stop in a main panel disconnect application 4th pole available as modular accessory Test mode switch position 	<ul style="list-style-type: none"> 3- or 4-pole non-fusible disconnect for standard OFF-ON or emergency stop in a main panel disconnect application 4th pole available as modular accessory Test mode switch position
Mounting Styles	20...63 A: DIN Rail/Panel mounting; 100...1250 A: Panel mounting	Panel mounting
Handles	<ul style="list-style-type: none"> Available in rotary styles, UL Type 1/3R/4/4X/12, IP66, standard, or test mode versions Handle colors in black and red/yellow and padlockable versions 30 A/60 A legend markers (optional) — uses Cat. No. 1492-MS6X12 markers 	<ul style="list-style-type: none"> Available in rotary styles, UL Type 1/3R/4/4X/12, IP66, or standard versions Handle colors in black and red/yellow and padlockable versions
Open Switch or Enclosed	<ul style="list-style-type: none"> Open switch Enclosed: UL/CSA rated enclosure for 20...63 A devices 	<ul style="list-style-type: none"> Open switch
UL/CSA Electrical Ratings:		
Rated Voltage U_e	690V AC	690V AC
Rated Current I_e	20...1200 A	100...1250 A
Rated Power P_e [FLA]	Varies w/ 1- or 3-phase switch, voltage	Varies w/ 1- or 3-phase switch, voltage
Short-Circuit Ratings	200 kA	200 kA
Mechanical Life [ops]	10 000	10 000
IEC Rated Current I_e		
AC-1	20...1200 A @ 690V	100...1250 A @ 690V
AC-21A	Varies w/ 1- or 3-phase switch, voltage	Varies w/ 1- or 3-phase switch, voltage
AC-22A	Varies w/ 1- or 3-phase switch, voltage	Varies w/ 1- or 3-phase switch, voltage
Ambient Operational Temp.	-20...+60 °C (-4...+140 °F)	-20...+60 °C (-4...+140 °F)
Ambient Enclosed Temp.	-20...+60 °C (-4...+140 °F)	-20...+60 °C (-4...+140 °F)
Ambient Storage Temp.	-40...+65 °C (-40...+149 °F)	-40...+65 °C (-40...+149 °F)
Protection class per IEC 529	<ul style="list-style-type: none"> Switch bodies: IP2 Fuse carriers: IP30 	<ul style="list-style-type: none"> Switch bodies: IP2
Optional Accessories	<ul style="list-style-type: none"> Operator handles Multi-length shafts Auxiliary contacts Terminal covers NFPA 79 internal handle with shaft 	<ul style="list-style-type: none"> IP66 handles Multi-length shafts Auxiliary contacts Terminal covers NFPA 79 internal handle

Standards Compliance and Certifications—Bulletin 194R-C, J, H, B, D, F, L, N, NU

Standards Compliance	Certifications
UL 98	CE Marked
UL 508	CSA Certified (File No. LR1234)
CSA C22.2, No. 14	UL Listed (File No. E 14841, Guide NLRV; File No. E 47426, Guide WHTY)
IEC/EN 60947-3 Low Voltage Switchgear and Controlgear part 3	
BS EN60947-3	
VDE 0660	
NEMA KS-1	

Standards Compliance and Certifications—Bulletin 194R-NE

Standards Compliance	Certifications
IEC/EN 60947-3 Low Voltage Switchgear and Controlgear part 3	CE Marked

Product Overview

The Bulletin 194R line of fused and non-fused rotary disconnect switches provides the flexibility to meet worldwide applications. The disconnect switches are UL Listed and CSA Certified and are designed to meet IEC 60947-3, VDE, DIN, BS and applicable NEMA requirements.

Features

- 20 A...1250 A Sizes
- Fused switch versions:
 - BS88 -DIN
 - CSA HRCII-C - CSA HRCI-MISC - HRC-L
 - UL Class J- UL Class CC - UL Class L
 - NFC
- Operating handle ingress ratings:
 - IP42 (Type 1)
 - IP66 (Type 3R, 3, 12, 4, 4X)
- Handle with or without test mode
- Padlockable handle for up to three padlocks
- 6 auxiliary contacts can be added
- Suitable as service entrance disconnecting means (UL 98)
- Suitable as at-motor disconnecting means (UL 508)

UL/CSA Fused Disconnect Switches



Cat. No. 194R-J30-1753



Cat. No. 194R-J100-1753



Note: Your order must include 1) Cat. No. of disconnect switch, 2) shaft, 3) handle, and 4) any accessories.

Rated Current [A]	Maximum Hp Ratings ^{(1)*}							Fuse	Dim. Ref.	Cat. No.
	1-Phase (60 Hz)		3-Phase (60 Hz)			DC				
	120V	240V	240V	480V	600V	125V	250V			
UL Class CC and CSA HRCI-MISC Fuses										
30	2	3	7.5	15	20	3	5	30 A CC, HRCI-Misc	A1	194R-C30-1753
UL Class J and CSA HRCI-J Fuses										
30	2	3	7.5	15	20	3	5	30 A Class J, HRCI-J	A1	194R-J30-1753
60	3	10	15	30	50	5	10	60 A Class J, HRCI-J	B1	194R-J60-1753
CSA HRCII-C Fuses										
30	2	3	7.5	15	20	3	5	30A HRCII-C	B1	194R-H30-1753
60	3	10	15	30	50	5	10	60A HRCII-C	B1	194R-H60-1753
UL Class J and CSA HRCI-J Fuses										
30	2	3	7.5	15	20	3	5	30 A Class J, HRCI-J	A1	194R-J30-1753
60	3	10	15	30	50	5	10	60 A Class J, HRCI-J	B1	194R-J60-1753
100	7-1/2	15	30	60	75	7.5	20	100 A Class J, HRCI-J	F5	194R-J100-1753 ⁽²⁾
200	—	25	60	125	150	15	40	200 A Class J, HRCI-J	F6	194R-J200-1753
400	—	50	125	520	350	20	50	400 A Class J, HRCI-J	F7	194R-J400-1753
600	—	—	200	500	500	—	—	600 A Class J, HRCI-J	F8	194R-J600-1753
UL Class L and CSA HRCI-L Fuses										
800	—	—	200	500	500	—	—	800 A Class L, HRCI-L	F9	194R-L800-1753

(1) Time delay fuses may be required to utilize the disconnect switch at its maximum horsepower rating.

(2) Integral terminal lug #12...#10 Solid Cu or #12 - #1 Stranded Cu.

Operating Handles (Accepts 3 Padlocks)

	Description	For Use With	Color	Degree of Protection	Cat. No.
	Padlockable handle, standard	<ul style="list-style-type: none"> Bul. 194R disconnect switches up to 60 A 	Black	Type 3R, 3, 12, 4, 4X	194R-PB
			Red/Yellow	Type 3R, 3, 12, 4, 4X	194R-PY
			Black	Type 3R, 3, 12, 4, 4X	194R-PBT
	Padlockable handle, test mode	<ul style="list-style-type: none"> Bul. 194R disconnect switches up to 60 A 	Red/Yellow	Type 3R, 3, 12, 4, 4X	194R-PYT
	Operating Handle Standard orientation with defeater	<ul style="list-style-type: none"> IEC Non-fused disconnect switches: 125... 630 A IEC Fused disconnect switches: 100... 400 A UL Disconnect switches: 100... 400 A 	Black	IP66 (Type 1, 3R, 12, 4, 4X)	194R-HM4
			Red/Yellow	IP66 (Type 1, 3R, 12, 4, 4X)	194R-HM4E
		<ul style="list-style-type: none"> IEC Non-fused disconnect switches: 800... 1250 A IEC Fused disconnect switches: 630... 1250 A UL Non-fused disconnect switches: 600... 1200 A UL Fused disconnect switches: 600... 800 A 	Black with light grey cover	IP65 (Type 1, 3R, 12, 4, 4X)	194R-HM4-L
			Red/Yellow	IP65 (Type 1, 3R, 12, 4, 4X)	194R-HM4E-L
	Operating Handle Standard orientation without defeater	<ul style="list-style-type: none"> IEC Non-fused disconnect switches: 800... 1250 A IEC Fused disconnect switches: 630... 1250 A UL Non-fused disconnect switches: 600... 1200 A UL Fused disconnect switches: 600... 800 A 	Black with light grey cover	IP65 (Type 1, 3R, 12, 4, 4X)	194R-HM4-N2-L
			Red/Yellow	IP65 (Type 1, 3R, 12, 4, 4X)	194R-HM4E-N2-L

OSHA Lockout/Tag Out Compliance (LOTO)

OSHA CFR36 Section 1910 mandates that disconnect switches be able to be locked out while in the OFF position during servicing. All Bulletin 194R handles comply with this important safety requirement. Please see NFPA Article 430 for disconnect requirements of motor applications.





Operating Shafts



	Description	For Use With	Operating Shaft Length	Cat. No.
	Extension shaft, Standard length	140U-P*, 194R-P*, and 194R- P*T handles	12 in. (30.48 cm)	194R-S1
			21 in. (53.34 cm)	194R-S2
	Extension shaft, Standard length	Bul. 194R-HM handles for • IEC Non-fused disconnect switches: 125...630 A • IEC Fused disconnect switches: 100...400 A • UL Disconnect switches: 100...400 A	12.6 in. (320 mm)	194R-R7
	Extension Shaft, Extended length		22.8 in. (580 mm)	194R-R8
	Extension shaft, Standard length	Bul. 194R-HM handles for • IEC Non-fused disconnect switches: 800...1250 A • UL Non-fused disconnect switches: 600...1200A	12.6 in. (320 mm)	194R-R9
	Extension Shaft, Extended length		22.0 in. (560 mm)	194R-R10
	Extension shaft, Standard length	Bul. 194R-HM handles for • IEC Fused disconnect switches: 630...1250 A • UL Fused disconnect switches: 600...800 A	12.6 in. (320 mm)	194R-R11
	Extension Shaft, Extended length		22.0 in. (560 mm)	194R-R12

NFPA 79 Internal Operating Handle with Shaft

An internal handle that permits operation of the disconnect switch when the panel door is open, in compliance with NFPA 79.

	Description	For Use With	Operating Shaft Length	Cat. No.
	NFPA 79 internal operating handle with shaft	140U-P*, 194R-P*, and 194R-P*T handles	12 in. (30.48 cm)	194R-N1
			21 in. (53.34 cm)	194R-N2
		100 . . . 400 A UL fused disconnect switches	12.6 in. (320 mm)	194R-HM4-NFPA1
			22 in. (560 mm)	194R-HM4-NFPA3
		600 . . . 800 A UL fused disconnect switches	12.6 in. (320 mm)	194R-HM4-NFPA2
			22 in. (560 mm)	194R-HM4-NFPA4

Terminal Shields

	Description	For Use With	No. of Poles	Mounting Position	Disconnect Switch Dim. Ref.	Qty Required per Disconnect Switch	Pkg. Qty	Cat. No.
	30 A IP20 Terminal Shroud (three terminals)	—	—	—	A1, A2	2	2	194R-30-C3
	60 A IP20 Terminal Shroud (three terminals)	—	—	—	B1, B2	2	2	194R-60-C3
	30 A IP20 Terminal Shroud (one terminal)	—	—	—	A1, A2	2	2	194R-30-C1
	60 A IP20 Terminal Shroud (one terminal)	—	—	—	B1, B2	2	2	194R-60-C1
	Terminal Shield	IEC Non-fused switches, 125 . . . 160 A	3	line or load side	F1	2	3	194R-LNC7
			4			2	4	194R-LNC8
		IEC Non-fused switches, 250 A	3		F2	2	3	194R-LNC9
			4			2	4	194R-LNC10
		IEC Non-fused switches, 400 . . . 630 A	3		F3	2	3	194R-LNC11
			4			2	4	194R-LNC12

Fused Disconnect Switches for UL Class Fuses and CSA HRCI-J

Electrical Ratings							
Cat. No.		194R-C30-1753		194R-J30-1753		194R-J60-1753	
CSA Fuse Type/UL Fuse Type		Class CC/HRCI-MISC ⁽¹⁾		Class J/HRCI-J		Class J/HRCI-J	
Maximum Fuse Cartridge Size	[A]	30		30		60	
Maximum Voltage, AC	[V]	600		600		600	
Maximum Voltage, DC	[V]	250		250		250	
Ampere Rating	[A]	30		30		60	
Maximum Short Circuit Prospective Fault Current	[kA]	200		200		200	
Fuse Operating Characteristics		Time Delay	Non-Time Delay	Time Delay	Non-Time Delay	Time Delay	Non-Time Delay
Maximum Hp, 3-Phase AC							
200V, 60 Hz	[Hp]	5	3	7.5	3	15	7.5
240V, 60 Hz	[Hp]	5	3	7.5	3	15	7.5
480V, 60 Hz	[Hp]	10	5	15	5	30	15
600V, 60 Hz	[Hp]	10	7.5	20	7.5	50	15
Maximum Hp, 1-Phase AC							
120V, 60 Hz	[Hp]	0.75	0.5	2	0.5	3	1.5
240V, 60 Hz	[Hp]	2	1.5	3	1.5	10	3
Maximum Hp, DC							
125V DC	[Hp]	2	3	3	2	5	5
250V DC	[Hp]	3	5	5	5	10	10

(1) Based on Rockwell Automation tests in accordance with the requirements as defined in CSA C22.2 No. 4, IEC 60947-3 and UL 98.

Electrical Ratings						
Cat. No.		194R-J100	194R-J200	194R-J400	194R-J600	194R-L800
Rated Current	[A]	100	200	400	600	800
Standards Compliance		UL 98, CSA22.2, No. 4				
Ratings per UL/CSA						
Maximum Voltage, AC	[V]	600				
Maximum Voltage, DC	[V]	250				
Maximum Short Circuit Fault Current	[kA]	200	100	100	100	100
Fuse Type						
UL		J	J	J	J	L
CSA		HRCI-J	HRCI-J	HRCI-J	HRCI-J	HRCI-L
Max. Fuse Rating	[A]	100	200	400	600	800
Max. Hp Rating, 3-phase						
240V	[Hp]	30	60	125	200	200
480V	[Hp]	60	125	250	500	500
600V	[Hp]	75	150	350	500	500
Max. Hp Rating, DC						
125V, 2 poles in series	[Hp]	7.5	15	20	—	—
240V, 3 poles in series	[Hp]	20	40	50	—	—

Specifications

Mechanical Data			
Cat. No.		194R-J30-1753	194R-J60-1753
Degree of Protection (per IEC 60947-3), Switch Only		IP20	IP20
Degree of Protection (per IEC 60947-3), Switch with Terminal Shield & Fuse Carriers		IP20	IP20
Mechanical Endurance ⁽¹⁾	Operations	10 000	10 000
Operating Torque (Maximum)	N•m	3.5	3.5
	lb•in	35	35
Terminal Capacity, Power Terminals	mm ²	2.5...10	2.5...25
	AWG	#14...#8	#14...#4
Terminal Capacity, Auxiliary Contact Terminals	mm ²	2.5...4	2.5...4
	AWG	#14...#12	#14...#12
Maximum Number of Auxiliary Circuits		6	6
Approximate Weight	kg	0.92	1.32
	lbs	2.03	2.9
Minimum Enclosure Size	Height [mm (in.)]	248 (9-3/4)	248 (9-3/4)
	Width [mm (in.)]	171 (6-3/4)	197 (7-3/4)
	Depth [mm (in.)]	148 (5-13/16)	148 (5-13/16)
Switch Dimension Reference (See dimension drawings.)		A1	B1

(1) Based on Rockwell Automation tests in accordance with the requirements as defined in CSA C22.2 No. 4, IEC 60947-3 and UL 98.

Electrical Ratings						
Cat. No.		194R-J100-1753	194R-J200-1753	194R-J400-1753	194R-J600-1753	194R-L800-1753
Degree of Protection (per IEC 60947-3), Switch Only		IP20	IP20	IP20	IP20	IP20
Degree of Protection (per IEC 60947-3), Switch with Terminal Shield & Fuse Carriers		IP20	IP20	IP20	IP20	IP20
Mechanical Endurance ⁽¹⁾	Operations	10 000	8 000	6 000	5 000	5 000
Operating Torque (Maximum)	N•m					
	lb•in					
Terminal Capacity, Power Terminals	mm ²		300 MCM	600 MCM; 2 x 300 MCM	2 x 600 MCM	2 x 600 MCM
	AWG	#12... #10 Solid Cu #12...#1 stranded	#6	#2 or 2 x #6	2 x #2	2 x #2
Terminal Capacity, Auxiliary Contact Terminals	mm ²	2.5...4	2.5...4	2.5...4	2.5...4	2.5...4
	AWG	#14...#12	#14...#12	#14...#12	#14...#12	#14...#12
Maximum Number of Auxiliary Circuits		4	8	8	8	8
Approximate Weight	kg	2.4	3.6	4.85	20	20
	lbs	5.3	7.9	10.7	44	44
Minimum Enclosure Size	Height [mm (in.)]	406 (16)	610 (24)	1000 (39.4)	1219 (48)	1219 (48)
	Width [mm (in.)]	610 (24)	508 (20)	800 (31.5)	914.5 (36)	914.5 (36)
	Depth [mm (in.)]	152 (6)	152 (6)	200 (11.8)	305 (12)	305 (12)
Switch Dimension Reference (See dimension drawings.)		F5	F6	F7	F8	F8

(1) Based on Rockwell Automation tests in accordance with the requirements as defined in CSA C22.2 No. 4, IEC 60947-3 and UL 98.

Non-Fused Disconnect Switches for IEC Applications

Non-fused disconnect switches must be used with separately installed fuses.

Electrical Ratings									
Cat. No.		194R-N30		194R-N60		194R-NE125		194R-NE160	
Maximum Voltage, AC	[V]	600		600		600		600	
Maximum Voltage, DC	[V]	250		250		250		250	
Ampere Rating	[A]	30		60		125		160	
Maximum Short Circuit Prospective Fault Current	[kA]	200		200		200		200	
Maximum Hp, 3-Phase AC									
200V, 60 Hz	[Hp]	7.5	3	15	7.5	—		—	
240V, 60 Hz	[Hp]	7.5	3	15	7.5	—		—	
480V, 60 Hz	[Hp]	15	5	30	15	—		—	
600V, 60 Hz	[Hp]	20	7.5	50	15	—		—	
Maximum Hp, 1-Phase AC									
120V, 60 Hz	[Hp]	2	0.5	3	1.5	—		—	
240V, 60 Hz	[Hp]	3	1.5	10	3	—		—	
Maximum Hp, DC									
125V DC	[Hp]	3	2	5	5	—		—	
250V DC	[Hp]	5	5	10	10	—		—	
Power Lost	[W]	2		6		—		—	

Electrical Ratings											
Cat. No.		194R-NE250		194R-NE400		194R-NE630		194R-NE800		194R-NE1250	
Maximum Voltage, AC	[V]	600		600		600		600		600	
Maximum Voltage, DC	[V]	250		250		250		250		250	
Ampere Rating	[A]	250		400		630		800		1250	
Maximum Short Circuit Prospective Fault Current	[kA]	200		200		200		100		100	

All Bulletin 194R Disconnect Switch Cat. Nos., 20...63 A Range

Environmental Data		
Ambient Temperature		
Open	°C (°F)	-2...+55 (-4...+131)
Enclosed	°C (°F)	-20...+40 (-4...+104)
Storage	°C (°F)	-40...+65 (-40...+149)
Altitude (per IEC 60947-1)		2 000
Relative Humidity (per IEC 60947-1)		90% @ +20 °C (+68 °F) 50% @ +40 °C (+104 °F)

Wiring Schematic

Figure 1 - Wiring Schematic

UL LISTED, CSA CERTIFIED	DIMENSION REFERENCE	CIRCUIT
Cat. No.		
194R-C30-1753	A1	
194R-J30-1753	A1	
194R-J60-1753	B1	
194R-H30-1753	B1	
194R-H60-1753	B1	
194R-N30-1753	A2	
194R-N60-1753	B2	
IEC SWITCHES	DIMENSION REFERENCE	CIRCUIT
Cat. No.		
194R-B20-1753	A1	
194R-B32-1753	A1	
194R-B63-1753	B1	
194R-D32-1753	B1	
194R-D63-1753	B1	
194R-F25-1753	A1	
194R-F32-1753	A1	
194R-F63-1753	B1	
194R-*1754	See Column W4 for the width of the 4-pole switch	

Approximate Dimensions

Dimensions are in millimeters (inches). Dimensions are not intended to be used for manufacturing purposes.

Figure 2 - Disconnect Switch Dimension References A1, A2, B1, and B2 (30 A and 60 A)

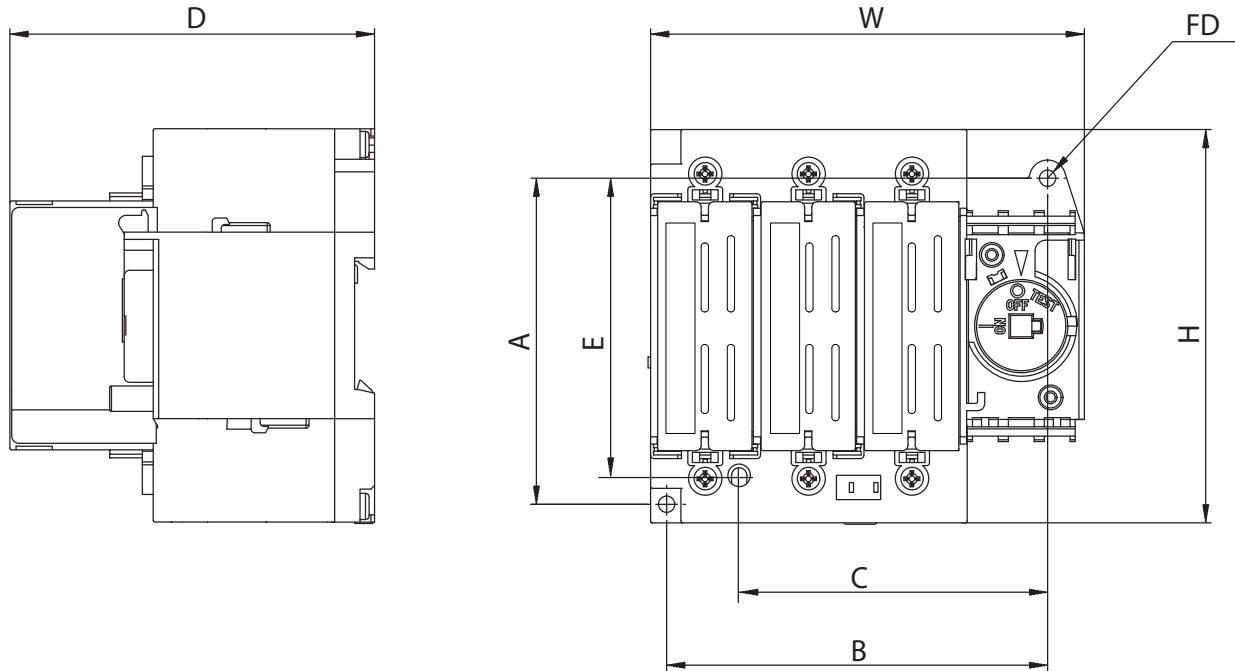

Disconnect Switch Dimension Reference	Approximate Dimensions [mm (in.)]								
	H	W (3-pole)	W (4-pole)	D	A	B	C ⁽¹⁾	E ⁽¹⁾	FD
A1	108 (4-1/4)	120 (4-3/4)	149 (5-7/8)	101 (4)	90 (3-9/16)	105 (4-1/8)	85 (3-11/32)	82 (3-15/64)	2-M4, 2-#8
A2	108 (4-1/4)	120 (4-3/4)	149 (5-7/8)	80 (3-1/8)	90 (3-9/16)	105 (4-1/8)	85 (3-11/32)	82 (3-15/64)	2-M4, 2-#8
B1	113 (4-29/64)	142 (5-19/32)	179 (7-3/64)	114 (4-31/64)	100 (3-15/16)	120 (4-23/32)	NA	NA	4-M4, 4-#8
B2	113 (4-29/64)	142 (5-19/32)	179 (7-3/64)	93 (3-43/64)	100 (3-15/16)	120 (4-23/32)	NA	NA	4-M4, 4-#8

(1) Mounting holes for backward compatibility with Bulletin 194R legacy switches.

Operating Handles

Figure 18 - Cat. Nos. 194R-P.../140U-P...

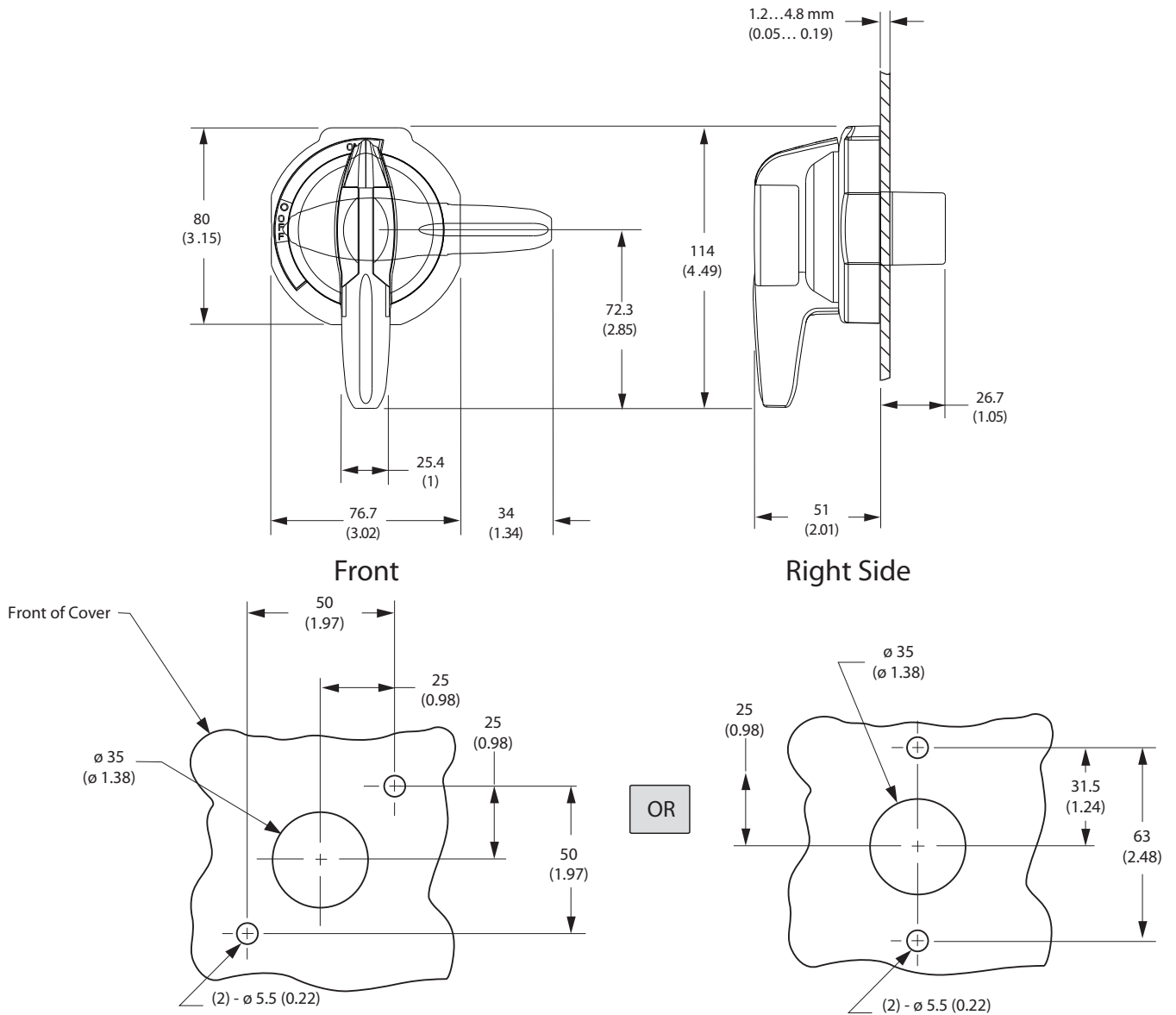

Enclosures

Figure 22 - Disconnect Switch Dimension References: A1, A2, B1, B2 (30 A and 60 A) Enclosure and Operating Handle

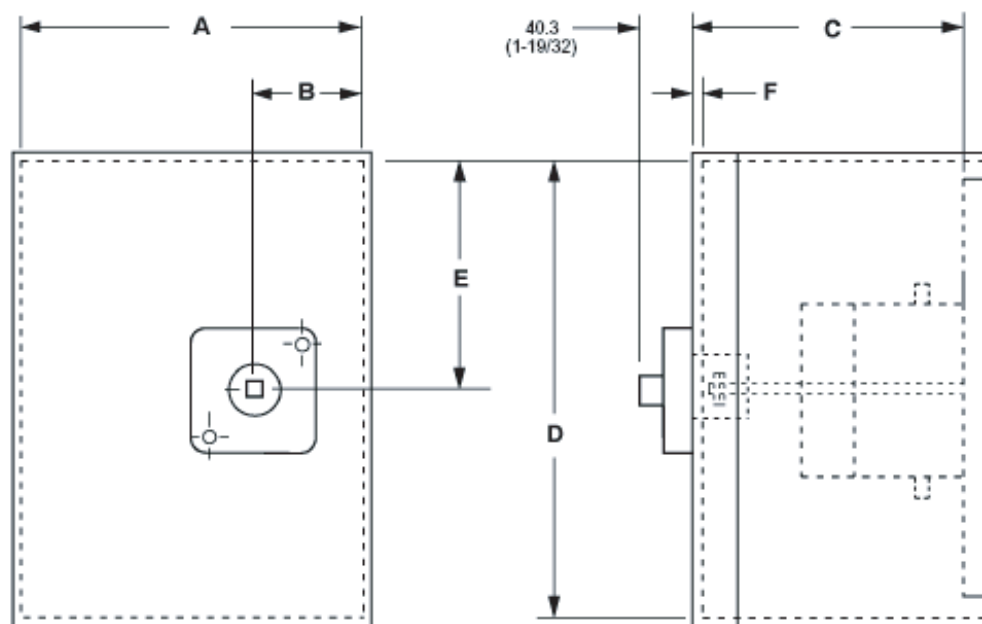

Cat. No.	Dimension Reference	A	B	C		D	E	F	
		Maximum	Minimum	Minimum	Maximum	Minimum	Minimum	Minimum	Maximum
194R-B20-1753	A1	171 (6-3/4)	45 (1-49/64)	147.6 (5-13/16)	454 (17-7/8)	248 (9-3/4)	89 (3-1/2)	1.4 (1/16)	4/78 (3/16)
194R-B32-1753									
194R-C30-1753									
194R-F32-1753									
194R-J30-1753									
194R-N30-1753	A2	171 (6-3/4)	45 (1-49/64)	111 (4-3/8)	454 (17-7/8)	248 (9-3/4)	89 (3-1/2)	1.4 (1/16)	4/78 (3/16)
194R-B63-1753	B1	197 (7-3/4)	45 (1-49/64)	147.6 (5-13/16)	454 (17-7/8)	248 (9-3/4)	105 (4-9/64)	1.4 (1/16)	4/78 (3/16)
194R-D32-1753									
194R-D63-1753									
194R-F63-1753									
194R-H30-1753									
194R-H60-1753									
194R-J60-1753									
194R-N60-1753	B2	197 (7-3/4)	45 (1-49/64)	111 (4-3/8)	454 (17-7/8)	248 (9-3/4)	105 (4-9/64)	1.4 (1/16)	4/78 (3/16)