



BULLETIN 194R

FUSED DISCONNECT SWITCH	-NC030P3
SECTIONNEUR PROTEGE PAR FUSIBLE	-NJ030P3
TRENNSCHALTER MIT SICHERUNG	-NN030P3
INTERRUPTOR DE DESCONEXION CON FUSIBLE	-NA100P3
INTERRUPTOR DE DESCONEXAO COM FUSIVEL	-NA200P3
	-NJ060P3
	-NN060P3
SEZIONATORE PORTA - FUSIBILI	-NA300P3

WARNING: To prevent electrical shock, disconnect from power source before installing or servicing. Install in suitable enclosure. Keep free from contaminants.

AVERTISSEMENT: Préalablement à l'installation et aux opérations de service, couper l'alimentation secteur pour empêcher tous chocs électriques. Installer dans une boîte appropriée. Protéger le relais contre les contaminants.

WARNING: Vor Installations oder Servicearbeiten Stromversorgung zur Vermeidung von elektrischen Unfällen trennen. Die Geräte müssen in einem passenden Gehäuse eingebaut und gegen Verschmutzung geschützt werden.

ADVERTENCIA: Desconéctese de la corriente eléctrica, antes de la instalación o del servicio, a fin de impedir sacudidas eléctricas. Instálelo en una caja apropiada. Manténgalo libre de contaminantes.

ADVERTÊNCIA: Para evitar choques, desconectar da corrente eléctrica antes de fazer a instalação ou a manutenção. Instalar em caixa apropriada. Manter livre de contaminantes.

AVVERTENZA: Togliere tensione prima dell'installazione. Installare in custodia idonea. Tenere lontano da contaminanti.

U.L. LISTED SWITCHES SECTIONNEURS AGREES UL SCHALTER MIT UL-ZULASSUNG LISTADO DE INTERRUPTORES U.L. CHAVES DA U.L. SEZIONATORE ELENCATI U.L.	DIMENSION REFERENCE REFERENCE DE DIMENSIONS KENNUNG FÜR ABMESSUNGSANGABEN REFERENCIA DE DIMENSIONES REFERENCIA DA DIMENSÃO REFERENZE DIMENSIONALI	CIRCUIT SCHALTUNG CIRCUITO
CAT.		
194R-NC030P3 194R-NJ030P3 194R-NJ060P3	A1 A1 B1	
194R-NN030P3 194R-NN060P3	A2 B2	
OTHER SWITCHES AUTRES SECTIONNEURS WEITERE SCHALTER OTROS INTERRUPTORES OUTRAS CHAVES ALTRI SEZIONATORI	DIMENSION REFERENCE REFERENCE DE DIMENSIONS KENNUNG FÜR ABMESSUNGSANGABEN REFERENCIA DE DIMENSIONES REFERENCIA DA DIMENSÃO REFERENZE DIMENSIONALI	CIRCUIT SCHALTUNG CIRCUITO
CAT.		
194R-NA100P3 194R-NA200P3 194R-NA300P3	A1 A1 B1	

U.L. RECOGNIZED ACCESSORIES	ACCESORIOS RECONOCIDOS FOR U.L.
ACCESSOIRES HOMOLOGUES UL	ACESSÓRIOS RECONHECIDOS PELA UL
U.L. ZUGELASSENES ZUBEHÖR	ACCESSORI RICONOSCIUTI U.L.

CAT.		CAT.	
194R-HS1 -HS4 -HS1E -HS4E	OPERATING HANDLE POIGNEE D'ACTIONNEMENT BEDIENÜNGSHEBEL MANDO OPERATIVO MANÍPULO DE ACCIONAMENTO MANIGLIA DI AZIONAMENTO	194R-FCA2 194R-FCJ60	FUSE COVER CACHE-FUSIBLES SICHERUNGSDECKEL TAPA DE FUSIBLE TAMPA DO FUSÍVEL COPRI-FUSIBILI
194R-R1 -R2	OPERATING SHAFT TIGE D'ACTIONNEMENT BETRIEBSWELLE EJE OPERATIVO VEIO DE ACCIONAMENTO ALBERO DI AZIONAMENTO	194R-LNC1 -LNC2	TERMINAL SHIELD BLINDAGE DE BORNE KLEMMENABSCHIRMUNG APANTALLAMIENTO DE BORNAS RESGUARDO DO TERMINAL PROTEZIONE DEI TERMINALI
194R-AA	AUXILIARY CONTACT ADAPTER ADAPTATEUR DE CONTACT AUXILLIAIRE HILFSKONTAKT-ADAPTER ADAPTADOR DE CONTACTO AUXILIAR ADAPTADOR DO CONTATO AUXILIAR ADATTATORE CONTATTO AUSILIARIO	195-GA01 -GA10 -GA11 -GA02 -GA20	AUXILIARY CONTACT CONTACT AUXILIAIRE HILFSKONTAKT CONTACTO AUXILIAR CONTATO AUXILIAR CONTATTO AUSILIARIO

OTHER ACCESSORIES	OTROS ACCESORIOS
AUTRES ACCESSOIRES	OUTROS ACESSÓRIOS
WEITERE ZUBEHÖRTEILE	ALTRI ACCESSORI

CAT.	
194R-SLA1 -SLA3	SHORTING LINKS CONTACTS DE PONTAGE DE MISE EN COURT-CIRCUIT KARZSCHLUSSBRÜCKEN PUENTES DE CORTOCIRCUITO BARRAS DE CURTO-CIRCUITO COLLEGAMENTI DI CORTOCIRCUITO

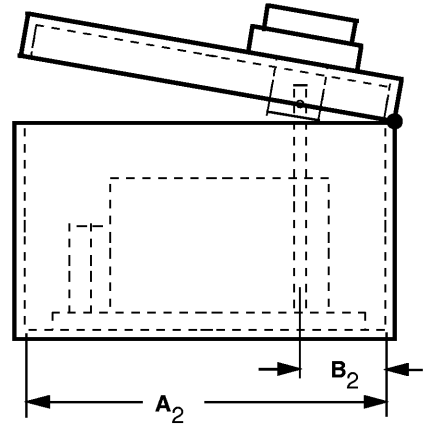
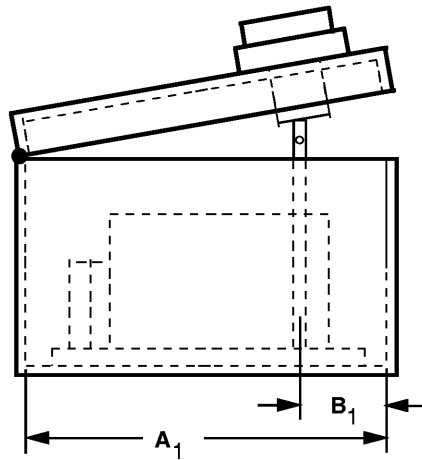
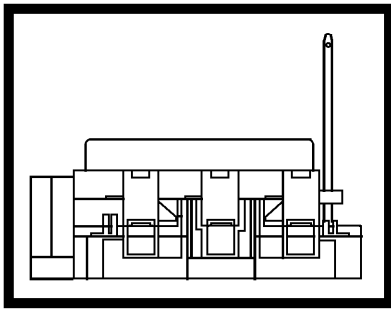

195-GA___, 2 MAXIMUM
 195-GA___, 2 MAX.
 195-GA___, MAX. 2
 195-GA___, MAXIMO 2
 195-GA___, 2 MAXIMO
 195-GA___, MASSIMO 2

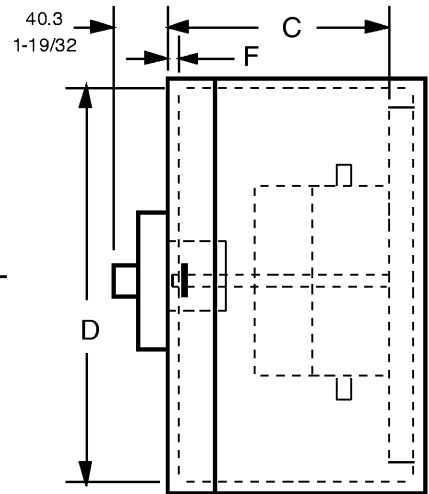
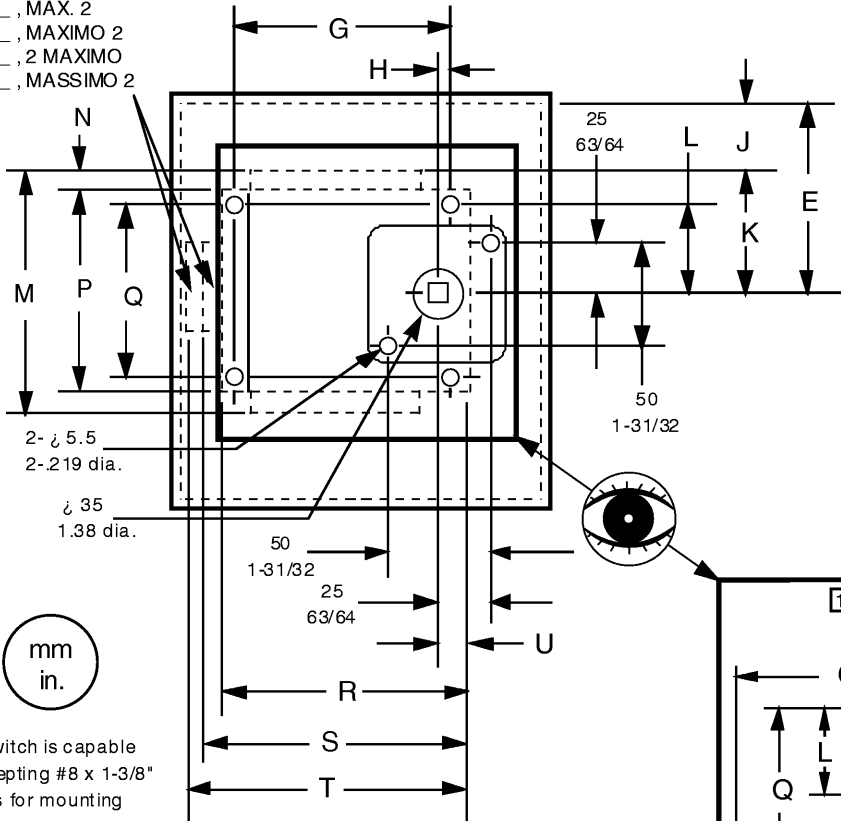

mm
in.

1 The switch is capable of accepting #8 x 1-3/8" screws for mounting

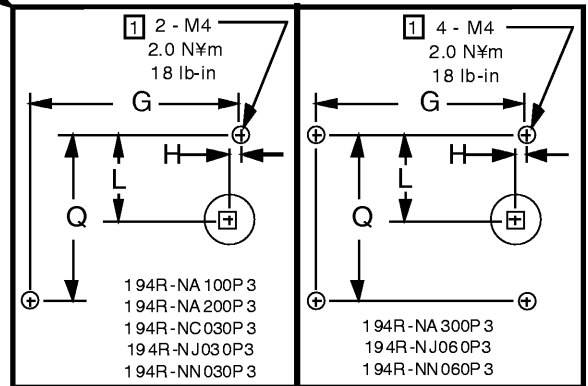

ENCLOSURE INSTALLATION DIMENSIONS
 EMCOMBREMENT DU BOITIER
 INSTALLATIONSABMESSUNGEN FÜR DIE SCHLTSCHRANKMONTAGE
 DIMENSIONES PARA INSTALACION EMPOTRADA
 DIMENSÕES PARA INSTALAÇÃO DO GABINETE
 DIMENSIONI PER INSTALLAZIONE IN CUSTODIA

CAT.	DIM. REF.		A ₁		A ₂		B ₁		B ₂		C		D	E	F	
			MINIMUM MINIMO MÍNIMO	MINIMUM MINIMO MÍNIMO	MINIMUM MINIMO MÍNIMO	MINIMUM MINIMO MÍNIMO	MINIMUM MINIMO MÍNIMO	MINIMUM MINIMO MÍNIMO	MINIMUM MINIMO MÍNIMO	MAXIMUM MÁXIMO MASSIMO	MINIMUM MINIMO MÍNIMO	MINIMUM MINIMO MÍNIMO	MINIMUM MINIMO MÍNIMO	MAXIMUM MÁXIMO MASSIMO		
194R-NA100P3 194R-NA200P3 194R-NC030P3 194R-NJ030P3	A1	mm	171	203	45	76	147.6	454	248	89	1.4	4.78				
		in.	6-3/4	7-63/64	1-49/64	3	5-13/16	17-7/8	9-3/4	3-1/2	1/16	3/16				
194R-NN030P3	A2	mm	171	203	45	76	111	454	248	89	1.4	4.78				
		in.	6-3/4	7-63/64	1-49/64	3	4-3/8	17-7/8	9-3/4	3-1/2	1/16	3/16				
194R-NA300P3 194R-NJ060P3	B1	mm	197	228	45	76	147.6	454	248	105	1.4	4.78				
		in.	7-3/4	8-63/64	1-49/64	3	5-13/16	17-7/8	9-3/4	4-9/64	1/16	3/16				
194R-NN060P3	B2	mm	197	228	45	76	111	454	248	105	1.4	4.78				
		in.	7-3/4	8-63/64	1-49/64	3	4-3/8	17-7/8	9-3/4	4-9/64	1/16	3/16				

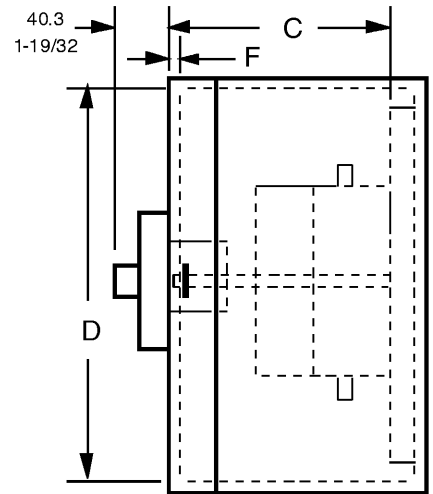
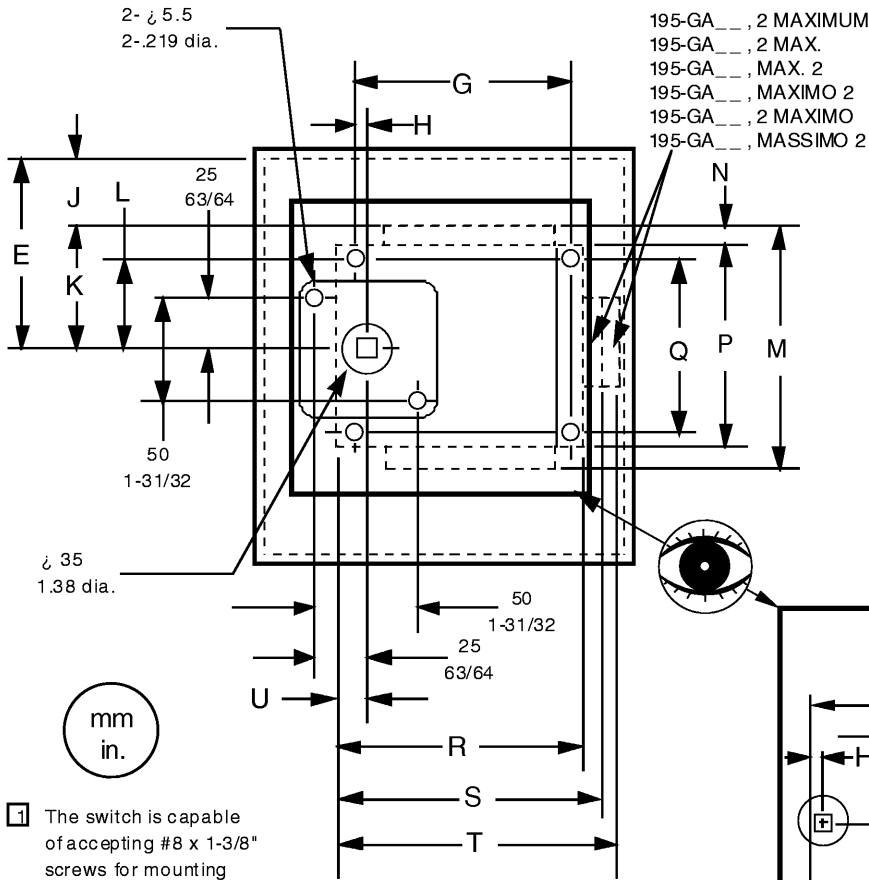
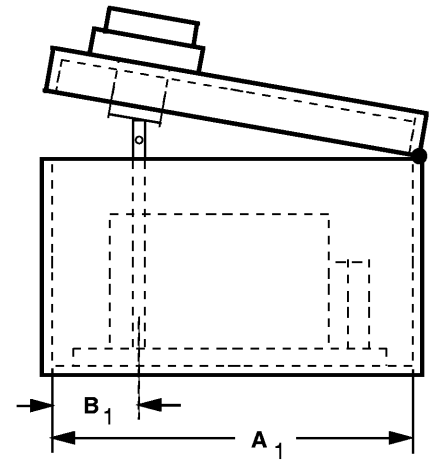
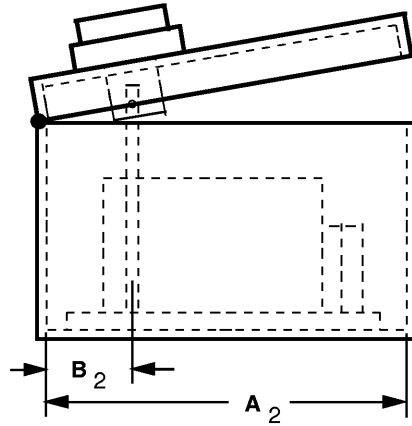
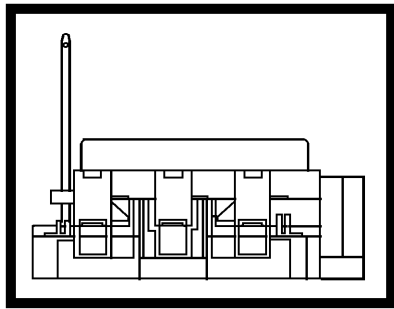

mm
in.

i The switch is capable of accepting #8 x 1-3/8" screws for mounting

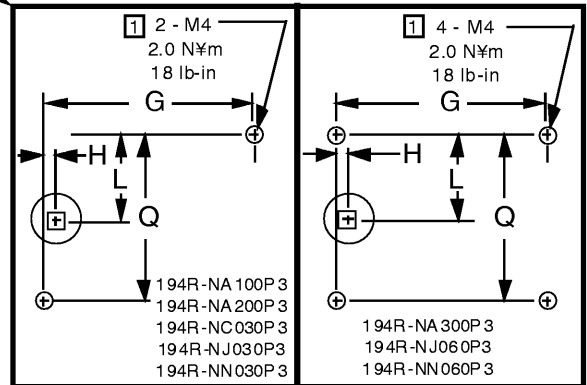

DISCONNECT SWITCH AND OPERATING HANDLE INSTALLATION DIMENSIONS
ENCOMBREMENT DU SECTIONNEUR ET DE LA POIGNEE D'ACTIONNEMENT
INSTALLATIONSABMESSUNGEN FÜR TRENNSCHALTER UND BEDIENUNGSHEBEL
DIMENSIONES DEL INTERRUPTOR DE DESCONEXION E INSTALACION NO EMPOTRADA
DIMENSOES PARA INSTALAÇÃO DA CHAVE SECCIONADORA E DA ALAVANCA DE ACIONAMENTO
DIMENSIONI PER L'INSTALLAZIONE DEL SEZIONATORE E MANIGLIA DI AZIONAMENTO

CAT.	DIM. REF.		G	H	J	K	L	M	N	P	Q	R	S	T	U
194R-NA100P3 194R-NA200P3 194R-NC030P3 194R-NJ030P3 194R-NN030P3	A1, A2	mm	85	7.5	24.2	64.8	41	129.6	11.8	106	82	102	114.1	126.2	12
		in.	3-11/32	19/64	61/64	2-35/64	1-39/64	5-7/64	15/32	4-11/64	3-15/64	4-1/64	4-1/2	4-31/32	15/32
194R-NA300P3 194R-NJ060P3 194R-NN060P3	B1, B2	mm	120	10	28.5	76.5	50	153	17.5	118	100	134	146.1	158.2	16
		in.	4-23/32	25/64	1-1/8	3-1/64	1-31/32	6-1/32	11/16	4-21/32	3-15/16	5-9/32	5-3/4	6-15/64	5/8

OPERATING SHAFT INSTALLATION
 INSTALLATION DE LA TIGE D'ACTIONNEMENT
 MONTAGE DER BETRIEBSWELLE
 INSTALACION DEL EJE OPERATIVO
 INSTALAÇÃO DO VEIO DE ACCIONAMENTO
 INSTALLAZIONE DELL'ALBERO DI AZIONAMENTO

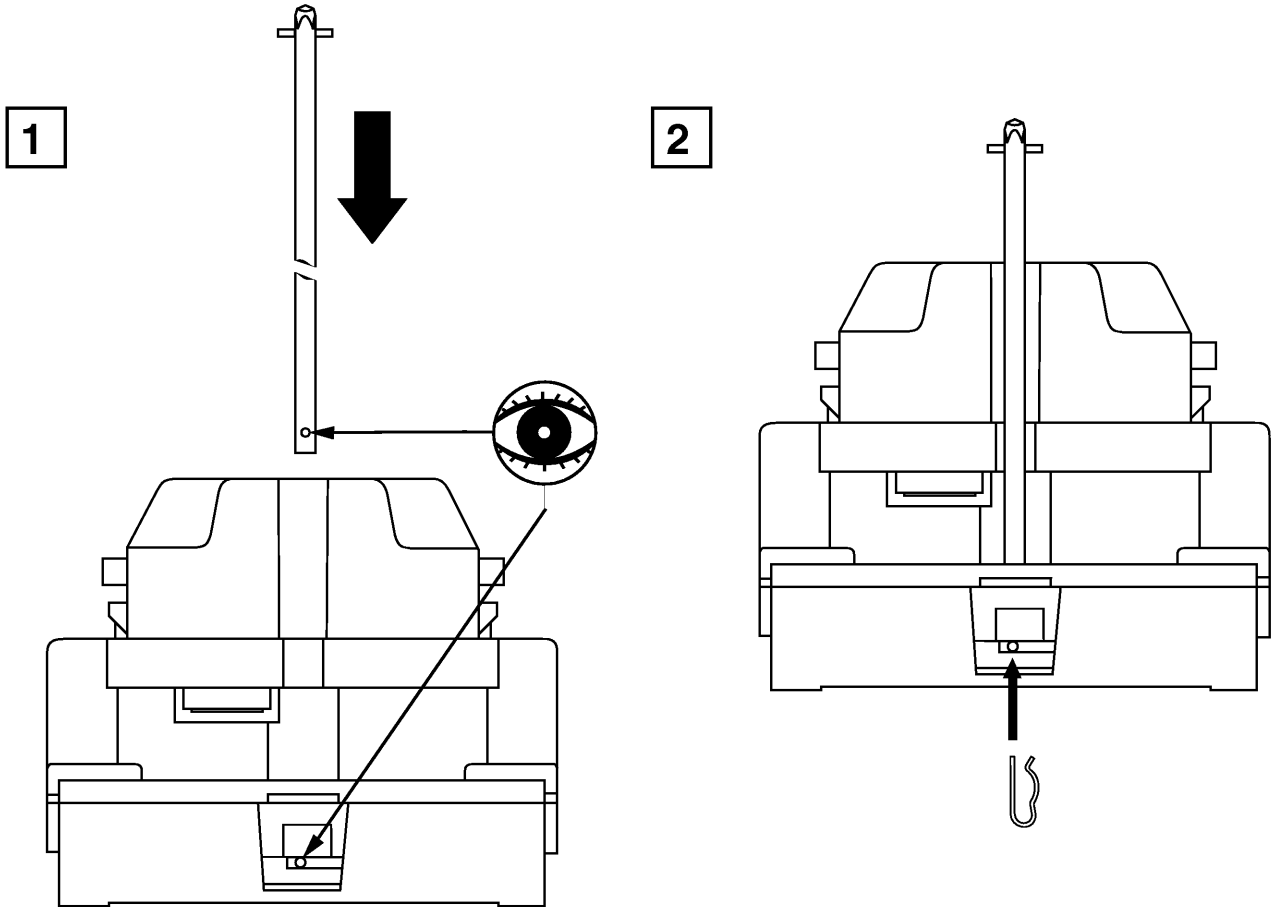

POWER WIRE INSTALLATION
 INSTALLATION DU FIL DE PUISSANCE
 INSTALLATION DES NETZKABELS
 INSTALACION DEL HILO DE ALIMENTACION
 INSTALAÇÃO DO CABO DE CORRENTE
 INSTALLAZIONE DEI CAVI DI LINEA

CAT.	DIM. REF.	A		B	
		mm ²	#AWG	Nºm	lb-in
194R-NA 100P3 194R-NA 200P3 194R-NJ 030P3 194R-NC 030P3 194R-NN 030P3	A1, A2	2.5-10	14-8	1.4	12
194R-NA 300P3 194R-NJ 060P3 194R-NN 060P3	B1, B2	2.5-25	14-4	4.0	35

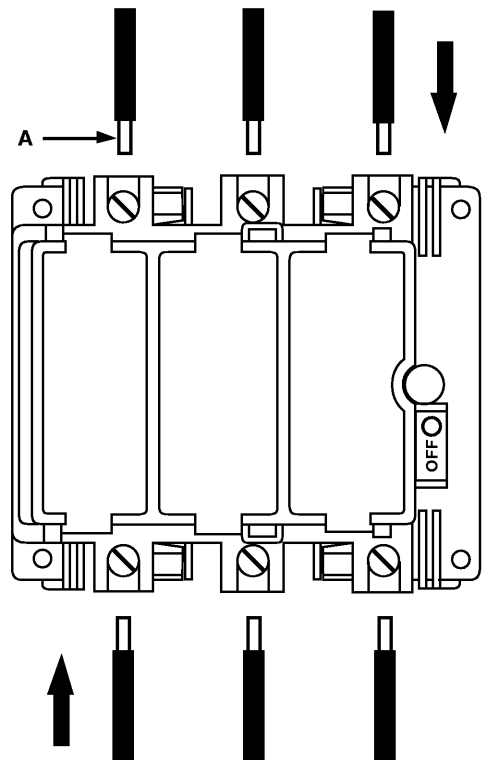
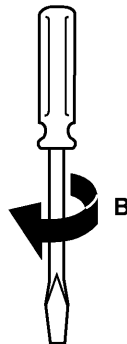

LINE TERMINAL SHIELD INSTALLATION
INSTALLATION DU BLINDAGE DE LA BORNE D'ALIMENTATION
MONTAGE DER LEITUNGSKLEMMEN-ABSCHIRMUNG
INSTALACION DEL APANTALLAMIENTO DE LAS BORNAS DE LINEA
INSTALAÇÃO DO RESGUARDO DO TERMINAL DO CABO
INSTALLAZIONE DELLA PROTEZIONE DEI TERMINALI DI LINEA

1

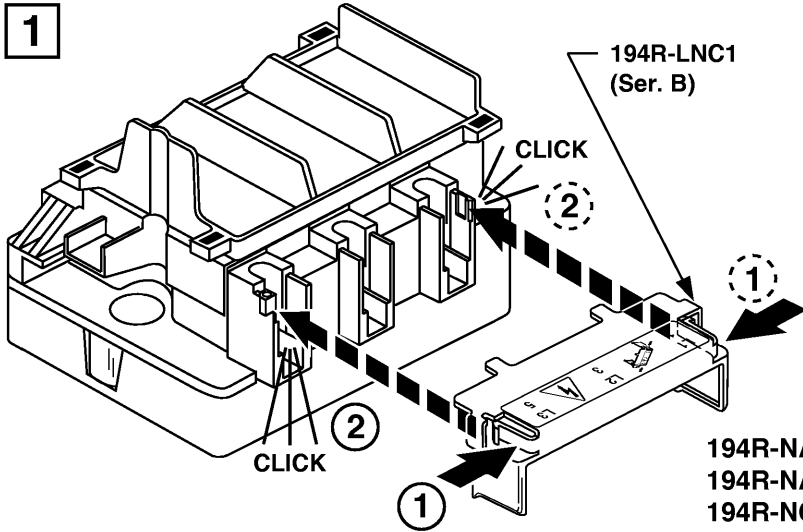

194R-LNC1
(Ser. B)

CLICK

2

1

194R-NA100P3
 194R-NA200P3
 194R-NC030P3
 194R-NJ030P3
 194R-NN030P3

2

OPTIONAL
 EN OPTION
 OPTION
 OPCIONAL
 OPZIONALE

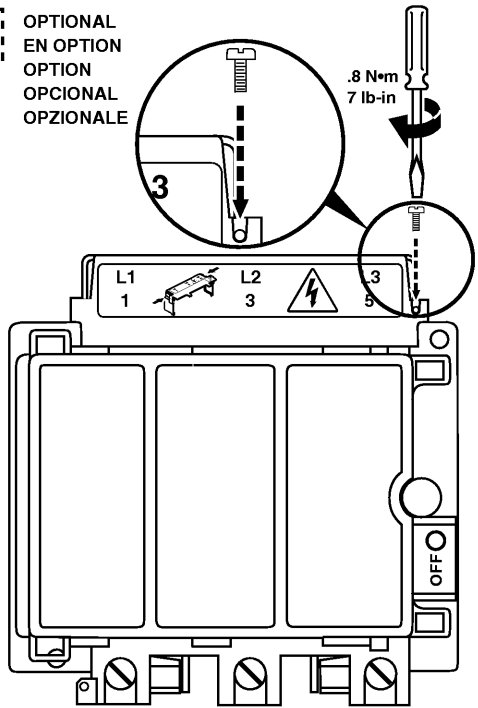

.8 N·m
7 lb-in

3

L1
1

L2
3

L3
5

OFF

1

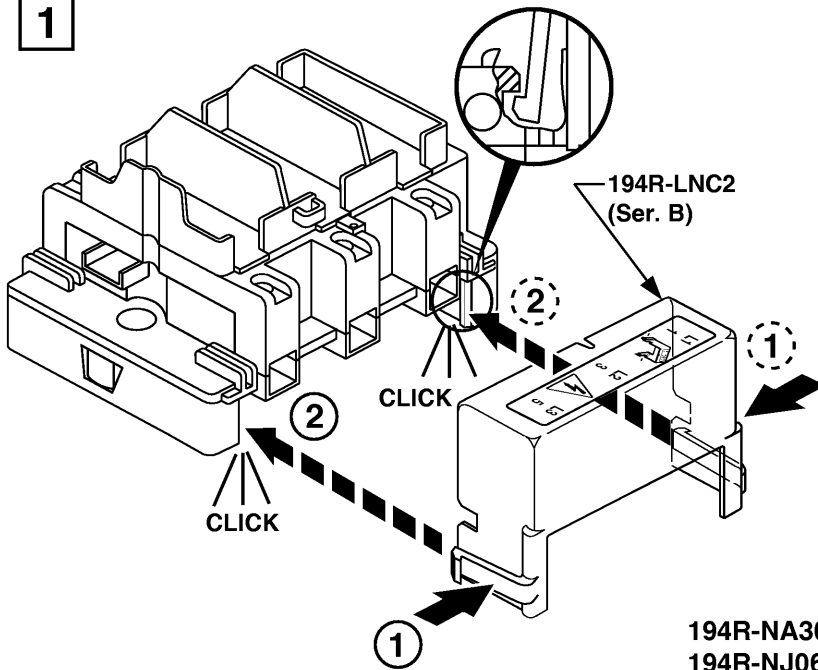

194R-LNC2
(Ser. B)

CLICK

2

1

194R-NA300P3
 194R-NJ060P3
 194R-NN060P3

2

OPTIONAL
 EN OPTION
 OPTION
 OPCIONAL
 OPZIONALE

.8 N·m
7 lb-in

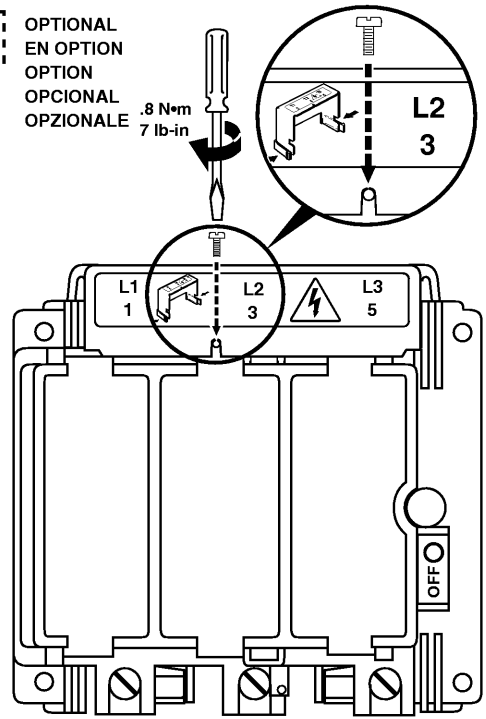

L2
3

L1
1

L2
3

L3
5

OFF

FUSE INSTALLATION
INSTALLATION DES FUSIBLES
EINSETZEN DER SICHERUNG
INSTALACION DE FUSIBLE
INSTALAÇÃO DOS FUSÍVEIS
INSTALLAZIONE DEI FUSIBILI

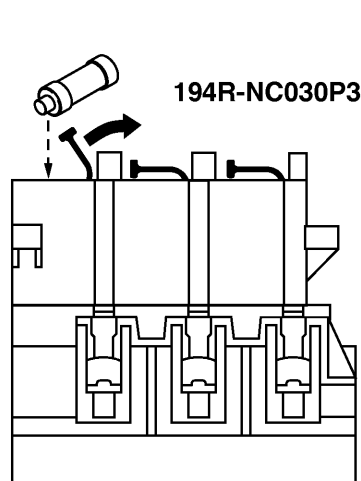

194R-NC030P3

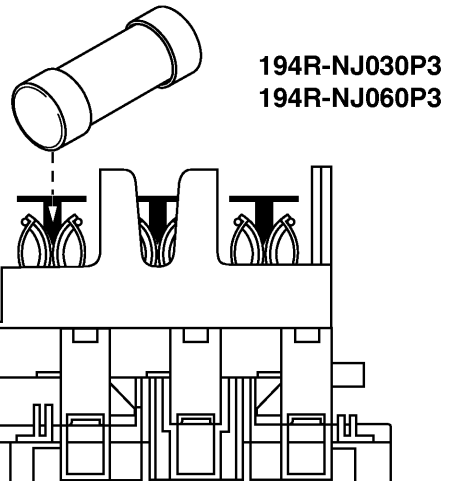

194R-NJ030P3
 194R-NJ060P3

**FUSE INSTALLATION
 INSTALLATION DES FUSIBLES
 EINSETZEN DER SICHERUNG
 INSTALACION DE FUSIBLE
 INSTALAÇÃO DOS FUSÍVEIS
 INSTALLAZIONE DEI FUSIBILI**

MAXIMUM FUSING RECOMMENDATIONS

① FUSES MUST BE SELECTED WITH REGARD TO THE MAXIMUM PROSPECTIVE FAULT CURRENT OF THE SYSTEM AND THE MAXIMUM CUTOFF CURRENT OF THE FUSE. WHEN SUBJECTED TO THAT MAXIMUM FAULT CURRENT, THE MAXIMUM FUSE CUTOFF CURRENT AS SPECIFIED FOR EACH DISCONNECT MUST NOT BE EXCEEDED.

INTENSITE MAXIMUM DE FUSIBLE RECOMMANDEE

① LES FUSIBLES DOIVENT ÊTRE CHOISIS EN TENANT COMPTE DU COURANT DE FUITE ÉVENTUEL MAXIMUM DU SYSTÈME ET DU COURANT DE COUPURE MAXIMUM DU FUSIBLE LORS D'UNE APPLICATION DE CE COURANT DE FUITE MAXIMUM, LE COURANT DE COUPURE MAXIMUM DU FUSIBLE, COMME IL EST PRÉCISÉ POUR CHAQUE SECTIONNEUR, NE DOIT PAS ÊTRE DÉPASSÉ.

EMPFÖHLENE MAX. ÄBSICHERUNG

① DIE AUSWAHL DER SICHERUNGEN MUSS AUF GRUNDLAGE DES MAXIMAL ZU ERWARTENDEN FEHLERSTROMS DES SYSTEMS UND DES MAX. AUSSCHALTSPITZENSTROMS ER SICHERUNG ERFOLGEN. BEI AUFTRETEN DIESES MAX. FEHLERSTROMS DARF DER FÜR JEDE TRENNUNG ANGEGEBENE MAX. AUSSCHALTSPITZENSTROM DER SICHERUNG NICHT ÜBERSCHRITTEN WERDEN.

RECOMENDACIONES MAXIMAS SOBRE FUSIBLES

① LOS FUSIBLES DEBEN SELECCIONARSE CON RESPECTO A LA CORRIENTE DE FALLA MAXIMUM ANTICIPADA DEL SISTEMA Y A LA CORRIENTE DE FUNDICIÓN MAXIMUM DEL FUSIBLE. AL SOMETIRSE A ESTA CORRIENTE DE FALLA MAXIMUM, LA CORRIENTE DE FUNDICIÓN MAXIMUM DEL FUSIBLE, COMMO ESPECIFICADO PARA CADA DESCONEJÓN, NO DEBE EXCEDERSE.

RECOMENDACÖES DOS VALORES MAXIMOS DOS FUSIVEIS

① OS FUSÍVEIS DEVEM SER SELECCIONADOS EM RELAÇÃO À CORRENTE MÁXIMA PROVÁVEL EM CASO DE AVARIA DO SISTEMA E EM RELAÇÃO À CORRENTE MÁXIMA DE ROTURA DO FUSÍVEL. QUANDO O SISTEMA É SUBJEITO À ESSA CORRENTE MÁXIMA DE AVARIA, À CORRENTE MÁXIMA DE ROTURA DO FUSÍVEL CONFORME ESPECIFICADA PARA CADA CORTE DO CIRCUITO NÃO DEVE SER EXCEDIDA.

CORRENTE MASSIMA DEL FUSIBILE RACCOMANDATA

① I FUSIBILI DEVONO ESSERE SELEZIONATI IN BASE ALLA CORRENTE MASSIMA DI GUASTO PREVISTA DEL SISTEMA E DELLA CORRENTE MASSIMA DI INTERVENTO DEL FUSIBILE. IN PRESENZA DI QUESTA MASSIMA CORRENTE DI GUASTO. NON DEVE ESSERE SUPERATA LA CORRENTE MASSIMA DI INTERVENTO DEL FUSIBILE COME SPECIFICATO PER OGNI SEZIONATORE.

CAT.	MAXIMUM SHORT CIRCUIT PROTECTIVE CURRENT COURANT MAXIMUM DE COURT - CIRCUIT PRESUME MAX. KURZSCHLUBSTROM		MAXIMUM MOTOR CIRCUIT FUSE LINK PUISSANCE NOMINALE MAXI DE LA CONNEXION DU FUSIBLE DU CIRCUIT MOTEUR MAX. BEMESSUNG DES SICHERUNGSELEMENTS FÜR DIE MOTORSCHALTUNG RfGIMEN MAX. DE LA CONEXIÖN DEL FUSIBLE DEL CIRCUITO MOTOR POTÆNCIA MÇXIMA DO FIO DO FUSËVEL DO CIRCUITO DO MOTOR POTENZA MASSIMA DEL FUSIBILE DEL CIRCUITO DEL MOTORE		MAXIMUM FUSE CUTOFF CURRENT COURANT MAXI DE COUPURE DU FUSIBLE MAX. AUSSCHALTSPITZENSTROM DER SICHERUNG CORRIENTE MAX. DE FUNDICIÖN DEL FUSIBLE CORRENTE MÇXIMA DE CORTE DO FUSËVEL CORRENTE MASSIMA DI INTERVENTO DEL FUSIBILE
	CORRIENTE MAXIMA DE CORTOCIRCUITO CORRENTE MÇXIMA DE CURTO-CIRCUITO CORRENTE MASSIMA DI PROTEZIONE DA CORTOCIRCUITO				
194R-NA100P3	80 KA		32M63		7.5 KA
194R-NA200P3	80 KA		32M63		7.5 KA
194R-NA300P3	80 KA		63M1 00		10 KA

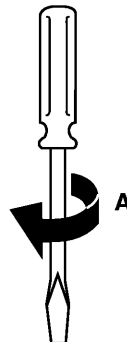
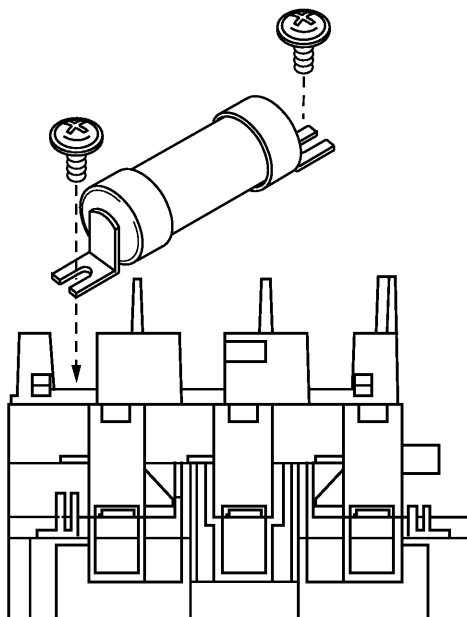

CAT	A	
	N¥m	LB-IN
194R-NA100P3	20	18
194R-NA200P3	37	33
194R-NA300P3	37	33