



Digital CMOS Laser Sensor GV Series

Instruction Manual

Read this manual before using the software in order to achieve maximum performance.
Keep this manual in a safe place after reading it so that it can be used at any time.

Note The displayed values indicate guidelines for distances and should not be used in the actual applications for measurement.

Safety Precautions

<p>WARNING</p>	<ul style="list-style-type: none"> This product is only intended to detect object(s). Do not use this product for the purpose to protect a human body or part of a human body. This product is not intended for use as an explosion-proof product. Do not use this product in a hazardous location and/or potentially explosive atmosphere.
-----------------------	---

Safety Precautions on Laser Products

<p>WARNING</p>	<ul style="list-style-type: none"> This product employs a semiconductor laser for its light source. Use of controls or adjustments or performance of procedures other than those specified herein may result in hazardous radiation exposure. Follow the instructions mentioned in this manual. Otherwise, injury to the human body (eyes and skin) may result. Do not disassemble this product. Laser emission from this product is not automatically stopped when it is disassembled. <p>Precautions on class II/2 laser products</p> <ul style="list-style-type: none"> Do not stare into the beam. Do not direct the beam at other people or into areas where other people unconnected with the laser work might be present. Be careful of the path of the laser beam. If there is a danger that the operator may be exposed to the laser beam reflected by specular or diffuse reflection, block the beam by installing an enclosure with the appropriate reflectance. Install the products so that the path of the laser beam is not as the same height as that of human eye. <p>Precaution on class 1 laser products</p> <ul style="list-style-type: none"> Do not stare into the beam.
-----------------------	---

Item	Description	
Model	GV-H45, GV-H130, GV-H450, GV-H1000	GV-H45L, GV-H130L, GV-H450L, GV-H1000L
Wavelength	655nm	
FDA (CDRH) Part 1040.10	Laser Class	Class II Laser Product
	Output	560μW
IEC 60825-1	Laser Class	Class 2 Laser Product
	Output	560μW

* The laser classification for FDA(CDRH) is implemented based on IEC60825-1 in accordance with the requirements of Laser Notice No.50.

Safety measures for the laser

Laser radiation emission indicator

The laser radiation emission indicator lights up after turning on the power and while the laser beam is being emitted.

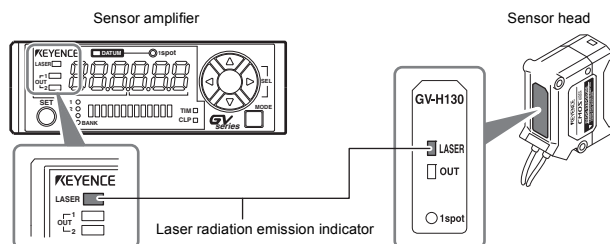

Laser emission stop input

The laser emission stops when an emission stop (purple line) signal is input (for 20 ms or longer). The emission stops while the signal is input. The laser beam is emitted a maximum of 20 ms after the signal input is canceled. The control output functions according to the detection value even while laser emission stop is input.

Laser warning labels

The following diagrams show the type and position of laser warning labels according to the GV Series.

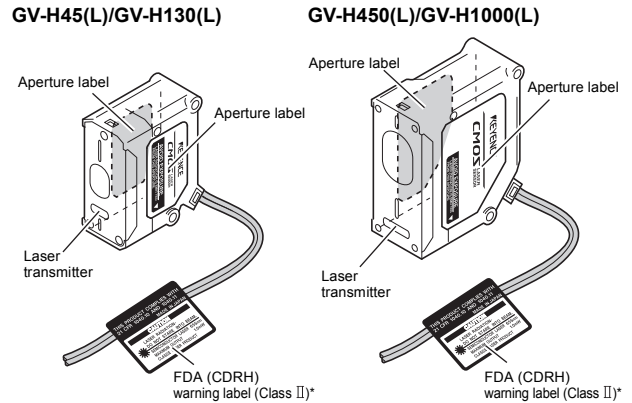

* Not included with GV-H45L/H130L/H450L/H1000L.

Aperture label



FDA (CDRH) warning label (CLASS II)



The FDA (CDRH) warning labels are only affixed to Class II laser products.

IEC warning/explanatory label (CLASS 2)



The IEC warning/explanatory labels are only included with Class 2 laser products.

When using this product in the countries and/or regions other than U.S., use the IEC warning/explanatory label in the package of this product.

In this case, it can be affixed on the FDA (CDRH) warning label, which has already been affixed to this product.

Checking the Package Contents

Check if the parts and equipment listed below are included in the package of the model you purchased before using the unit.

Sensor amplifier

GV-21/GV-21P (main unit)

GV-22/GV-22P (expansion unit)

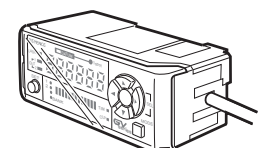
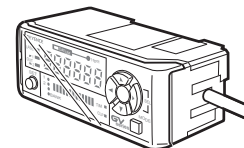

Amplifier x1
Instruction manual x1

Amplifier x1

Sensor head

GV-H45(L)/H130(L)

GV-H450(L)/H1000(L)

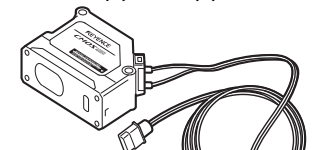
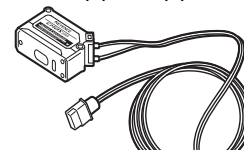

Sensor head x1
Insulating sheet x1
Mounting bracket x1
Board nut x1
M3 x L30 screw x2
Laser warning sticker* x1

Sensor head x1
Insulating sheet x1
Mounting bracket x1
Board nut x1
M4 x L30 screw x2
Laser warning sticker* x1

* This is not included with GV-H45L/H130L/H450L/H1000L.

We have thoroughly inspected the package contents before shipment. However, in the event of defective, broken or missing items, please contact your nearest KEYENCE office.

Mounting and Wiring the Sensor Amplifier

Mounting the sensor amplifier

■ Mounting the GV-21/GV-21P (main unit)

1 Align the claw at the bottom of the main body with the DIN rail. While pushing the main body in the direction of the arrow 1, slant it in the direction of the arrow 2.

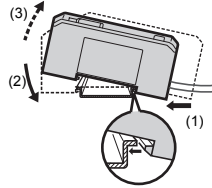

2 To dismount the sensor, raise the main body in the direction of the arrow 3 while pushing the main body in the direction of the arrow 1.

When using the amplifier mounting bracket (OP-76877) (sold separately), mount it as shown in the diagram to the right.

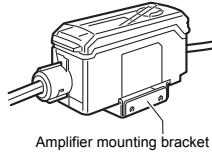

■ Mounting the GV-22/GV-22P (expansion unit)

Several expansion units can be used in connection with the main unit. Up to three expansion units can be connected to one main unit.

<p>CAUTION</p>	<ul style="list-style-type: none"> When connecting multiple amplifiers (expansion units), first check to make sure that the power is turned off to all of the main and expansion units. Connecting the units with the power turned on may cause damage to the units. Push the amplifiers (expansion units) as far as possible into the main unit. If they are connected at a slant or not inserted securely, the units may be damaged. Only GV Series amplifier can be connected (DL Series cannot be connected). Connecting other amplifiers may cause damage to the units.
-----------------------	---

Note Expansion units with different output types (such as a PNP output main unit to an NPN output expansion unit) cannot be connected together.

1 Remove the expansion protective cover from the GV-21/GV-21P (main unit)

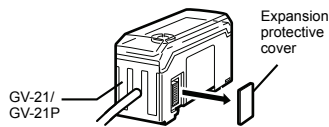

2 Install the amplifiers (expansion units) on the DIN rail.

For more information about mounting, see "Mounting the GV-21/GV-21P (main unit)".

3 Push the expansion unit into the main unit connector until a clicking sound can be heard.

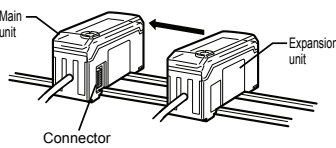

4 Install the end units (OP-26751: 2 units in a set) (sold separately) on either side of the amplifiers (main or expansion units). Secure the end units in place with screws on top (2 on each end unit).

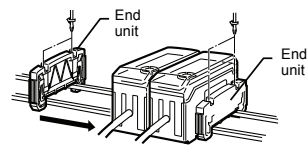

The end units are mounted in the same way as the amplifiers.

Amplifier wiring

The following information shows the I/O cable. For more information about the I/O circuit, see page 9 of this Instruction Manual.

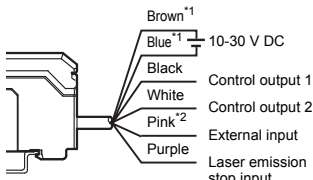

*1 GV-22/GV-22P (expansion unit) do not have brown or blue lines. Power is supplied to the expansion units through GV-21/GV-21P (main unit).

*2 The external input switches as shown below depending on the amplifier OPTIONAL settings.

- oFF Input off
- SFT External shift
- bnK Bank switching
- tim Timing input

Connecting and Mounting the Sensor Head

Sensor head part names

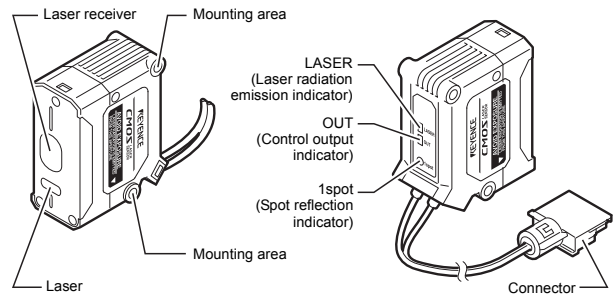

Connecting the sensor head

1 Unlock the sensor head connector and insert it into back of the amplifier.

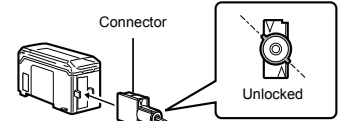

2 Turn the round part of the connector clockwise until a clicking sound is heard to lock it.

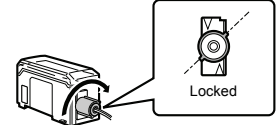

Note When shortening the sensor head cable, follow the instructions given in the "Sensor Head Connector Assembly Manual" included with the sensor head.

Mounting the sensor head

Use the dedicated mounting bracket to mount the sensor head. When not using the dedicated mounting bracket, the included insulating sheet must be inserted between the mounting surface and the sensor head as shown in the diagram. (When using the dedicated mounting bracket, the insulating sheet is not necessary.)

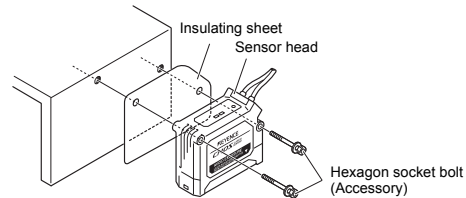

● **Mounting when detecting targets close to a wall**

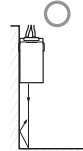

Receives little effect from stray laser light.



Variations in the detection value with effects from stray laser light.

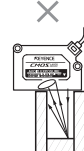

The target cannot be detected when the transmitter or receiver are blocked.

● **When detecting uneven workpieces**

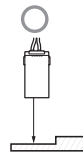

• Stable detection even on uneven areas.

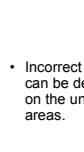

• Incorrect values can be detected on the uneven areas.

Sensor Amplifier

Sensor amplifier part names

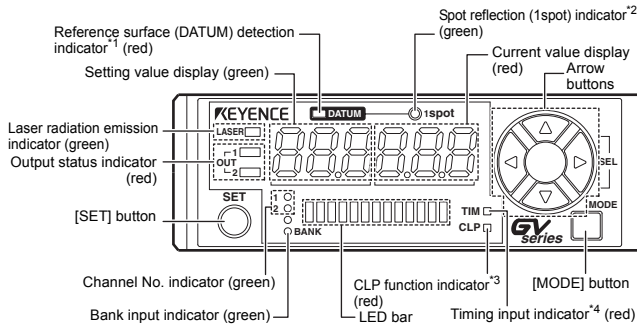

- *1 The reference surface (DATUM) detection indicator lights up when performing reference surface detection. For more information, see "Reference surface detection (DATUM) method (Application)" on page 5 of this Instruction Manual.
- *2 The spot reflection indicator lights up during normal detection and turns off during multiple reflection (when multiple peaks of received light intensity occurs due to diffuse reflection), insufficient light intensity, and when the target is out of the detection range.
- *3 For more information about the CLP (clamp) function indicator, see "4. Clamp function setting" on page 8 of this Instruction Manual.
- *4 For more information about the timing input indicator, see "8. External input setting" on page 8 of this Instruction Manual.

Main screen

The main screen can be switched between "Current/setting value display" and "Peak/bottom value display". The main screen can be switched even during keylock.

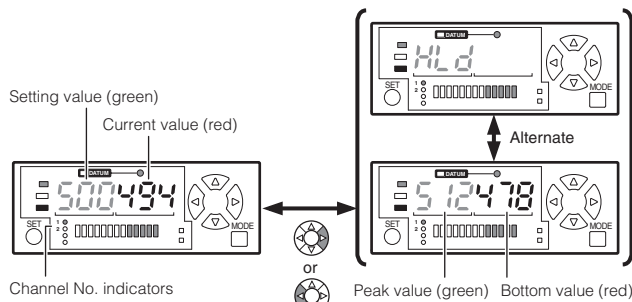

- Setting value/current value display**
Pressing the [MODE] button switches the channels (channel No. indicators).
- Peak value/bottom value display**
Pressing the [UP] arrow button resets the peak and bottom values.

Pressing the [Up] and [Down] arrow buttons simultaneously on the main screen forces the current value (red) to 0.

* With the default settings. For details, see "9. Shift target value setting" on page 9 of this Instruction Manual.

Note When the channel No. 1 indicator is lit, the control output 1 (black line) setting value is displayed. When the channel No. 2 indicator is lit, the control output 2 (white line) setting value is displayed. Operations are different in F-2 mode. (See page 5 of this Instruction Manual.)

● Current value and display resolution

In the default state, the current value shows 0 when the workpiece is located at the maximum detection distance. Bringing the workpiece closer to the sensor head gradually increases the value and displays it up to the minimum detection distance.

Item	Current value			
	GV-H45 (L)	GV-H130 (L)	GV-H450 (L)	GV-H1000 (L)
Detecting range (mm)	20.0 to 45.0	55.0 to 130.0	160 to 450	200 to 1000
Digital display (initial)	250 to 0	750 to 0	290 to 0	800 to 0
Display resolution	1	2	1	5

Note The displayed values indicate guidelines for distances and should not be used in the actual applications for measurement.

Example When using sensor head GV-H130

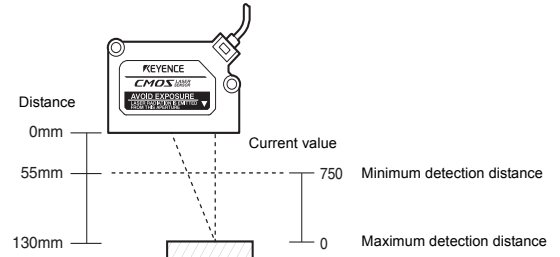

For example, when using the defaults with the setting value (green) at 500, the comparator output turns on when the current value is 500 or greater and turns off when it is less than 500.

If multiple reflection (when multiple peaks of received light intensity occurs due to diffuse reflection) occurs during F-1, F-2, or A-1 modes, the value immediately before the current value is held.

● Setting value

The following table shows the default setting values for each channel.

Operation mode	Item	Default value			
		GV-H45 (L)	GV-H130 (L)	GV-H450 (L)	GV-H1000 (L)
F-1, A-1, A-2	Control output 1 (black) (Channel 1 lit)	150	500	200	500
	Control output 2 (white) (Channel 2 lit)	125	400	150	400
F-2	Control output 1 (black) HIGH (Channel 1 lit)	150	500	200	500
	Control output 1 (black) LOW (Channel 2 lit)	100	300	100	300
	Control output 2 (white) HIGH (Channel 1 flashing)	125	400	150	400
	Control output 2 (white) LOW (Channel 2 flashing)	75	200	50	200

● Peak/bottom values

- Peak value:** Resets when the detection value exceeds the setting value and holds the maximum value (peak value) until the detection value falls below the setting value again.
- Bottom value:** Resets when the detection value falls below the setting value and holds the minimum value (bottom value) until the detection value exceeds the setting value again.

Reference The held peak and bottom values can be cleared by pressing and hold the [Up] arrow button.

Using Basic Operations

Configure the sensitivity setting in F-1 mode (with the default settings).

2-point calibration

The setting is automatically calculated as the mean value detected from two points: with the workpiece and without the workpiece.

1 Press the [SET] button once without a workpiece in place.

The current value without the workpiece is read.



2 Place a workpiece in the detection position, and quickly press the [SET] button once again.

This concludes 2-point calibration and the sensor returns to the detection state.

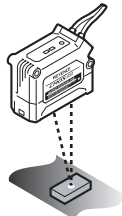

Reference If there is very little difference between the values obtained in Step 1 and Step 2, then "----" flashes in the setting value display area after calibration is complete. The setting value is still updated.

Fine-tune setting value

Use the [Up] and [Down] arrow buttons to fine-tune the setting value.

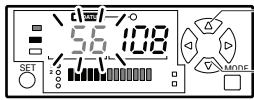

Increases the setting value

Decreases the setting value

Item	Setting range
Setting value fine-tuning	-199 to 999

Reference surface (DATUM) calibration

Use DATUM calibration when comparator output cannot be performed correctly during 2-point calibration (due to problems such as chattering from the surface of the workpiece).

3 Press the [SET] button once without a workpiece in place (reference surface).

4 Using the same conditions,



Configuring the Sensitivity Setting and Operation Mode

Detection method

The GV Series has two type of detection methods: "Distance detection method" and "Reference surface (DATUM) detection method". The reference surface (DATUM) detection method can only be used when performing reference surface calibration.

Note Control output 2 is fixed to distance detection method for all operation modes.

Distance detection method (Normal)

Detects the distance between the detection target and the sensor head, and then performs control output. The following table shows each operation mode and the auto calibration that can be used.

Operation mode		Description	Usable auto calibration
General	F-1	Normal detection mode The most general mode. ON/OFF judgment is performed based on one setting value.	2-point calibration Full auto calibration Maximum sensitivity setting
	F-2	Area detection mode On/OFF judgment is performed on an area based on two settings.	2-point area calibration 1-point area calibration
Special	A-1	Edge hold mode Detects the change in distance (derivation) to the target and holds the display.	2-point calibration Full auto calibration Maximum sensitivity setting
	A-2	Surface detection mode When multiple beams of light are reflected from the detection target, the closest reflected light is judged as the detection value.	2-point calibration Full auto calibration Maximum sensitivity setting

Area detection mode (F-2 mode)

Operation image

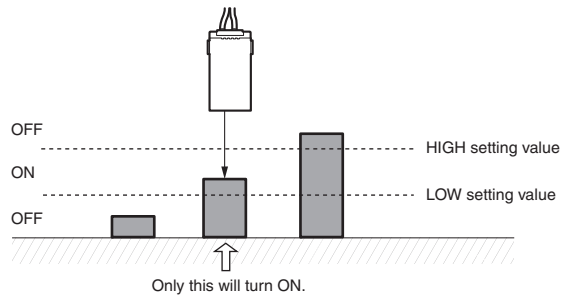

When using the F-2 mode, the channel No. indicator switches in the following order each time the [MODE] button is pressed.

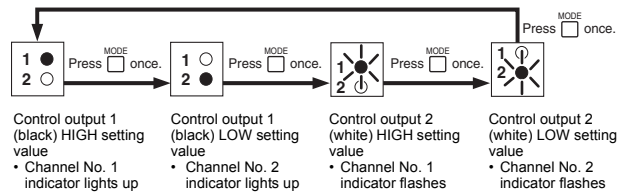

● **Edge hold mode (A-1 mode)**

This operation mode is suitable for detecting workpieces on a conveyor or detecting workpieces with waving backgrounds. It ignores slow distance changes and only detects workpieces (sudden changes in height).

When height differences greater than the setting value are detected (low areas become high), the value at the detected time are held and displayed, and control output starts. If the difference is small and does not exceed the setting value, the display stays as 0. When height differences greater than the setting value are detected (high areas become low), detection value becomes 0 and control output is stopped.

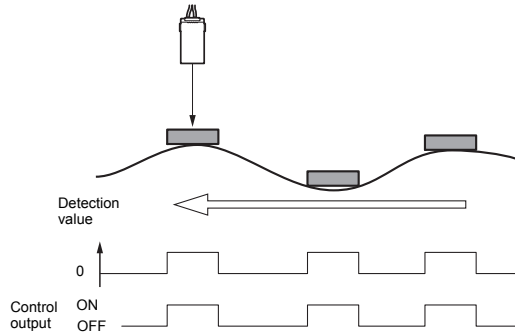

- Note**
- When edge hold mode (A-1 mode) is selected, edge hold mode only operates on channel 1. Channel 2 operates under distance measurement mode (F-1 mode).
 - If the edges are gentle (such as spherical or tilted workpieces), this mode may not be able to detect workpieces or may output the value incorrectly.
 - Send the workpiece past the sensor head so that the area for detecting height differences is parallel to the sensor head. See "When detecting uneven workpieces" (page 3).

- Reference**
- When a detection value is being held, press and hold the [Up] and [Down] arrow buttons at the same time to set the current value to 0 (regardless of the shift target value) and to turn off output. The current value for channel 2 changes to 0 as well.
 - If the external input function is set to "SF" and the external input (pink line) is turned on, the control output turns off and the current value becomes 0. (When channel 2 is selected, the current value becomes 0 as well. Turning the laser emission stop input on and off performs a similar action, but it only changes the current value of the channel to 0.)

■ **Reference surface detection (DATUM) method (Application)**

This method memorizes the background (reference surface) and uses it to perform comparator output when there is a workpiece (when the state differs from the reference surface).

The reference surface detection (reference surface calibration) can only be used on Channel 1 of operation mode F-1/F-2.

Operation mode	Description	Changes to the setting value
General F-1	Turns on control output when the detected surfaces is not the same as the memorized reference surface.	The setting value can be configured around 0. Individual setting values cannot be changed.
Special F-2	The current value for the memorized surface is forcibly set to 0. (The display is common for channels 1 and 2.)	The setting value can be configured around 0. Individual setting values can be adjusted.

Use the reference surface (DATUM) detection method in the following situations:

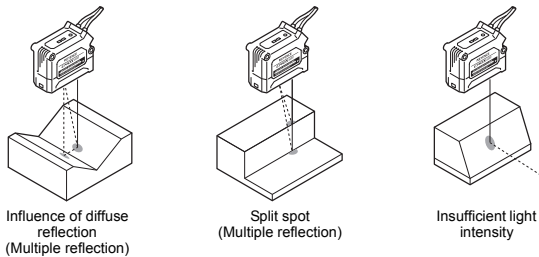

During reference screen (DATUM) detection, the background is memorized as references. During the unstable situations noted above, a workpiece is judged as present when the detected surface is different from the background.

This makes stable detection possible even when using workpieces with unstable shapes.

The reference surface (DATUM) detection indicator lights up when using reference surface detection after performing reference surface (DATUM) calibration.

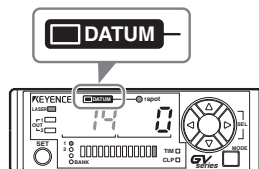

Configuring the sensitivity setting for distance detection method

■ **2-point calibration (operation modes: F-1, A-1, A-2)**

- 1 Press the [SET] button once without a workpiece in place.
The current value without the workpiece is read.

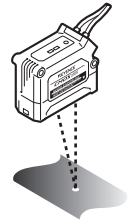

- 2 Place a workpiece in the detection position, and quickly press the [SET] button once again.
The setting value is calculated as the mean value between the value obtained in step 1 and the value obtained in step 2.
This concludes 2-point calibration and the sensor returns to the detection state.

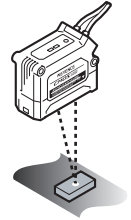

Reference If there is very little difference between the values obtained in Step 1 and Step 2, then "----" flashes in the setting value display area after calibration is complete. The setting value is still updated.

■ **Maximum sensitivity setting (operation modes: F-1, A-1, A-2)**

- 1 Press and hold the [SET] button for at least three seconds without a workpiece in place.
- 2 Release the [SET] button when "SEt" flashes on the display.
This concludes maximum sensitivity calibration and the sensor returns to the detection state.

■ **Full auto calibration (operation modes: F-1, A-1, A-2)**

This method performs calibration while the target is moving.

- 1 Press and hold the [SET] button for at least three seconds while the target workpiece is passing through the detection area for the sensor.
The sensitivity is set according to the detection value while the [SET] button is pressed.
- 2 Release the [SET] button when "SEt" flashes on the display.
This concludes calibration and the sensor returns to the detection state.

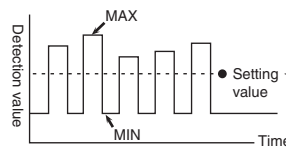
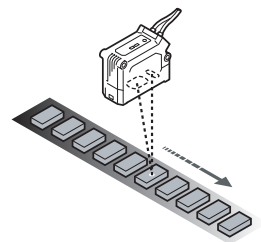

The value is set to the mean value between the maximum and minimum values detected while the [SET] button is pressed down.

■ **2-point area calibration (operation mode: F-2)**

- 1 Place a workpiece on the upper limit that you want the sensor to detect, and press the [SET] button once.
That upper limit becomes the HIGH setting value.
- 2 Place a workpiece on the lower limit that you want the sensor to detect, and press the [SET] button once.
That lower limit becomes the LOW setting value.

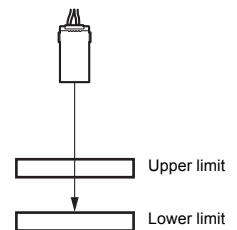

Reference If there is very little difference between the values obtained in Step 1 and Step 2, then "----" flashes in the setting value display area after calibration is complete. The setting value is still updated.

1-point area calibration (operation mode: F-2)

1 Press and hold the [SET] button for at least three seconds with the workpiece that you want to detect in place.

2 Release the [SET] button when "SEt" flashes on the display.

This concludes 1-point area calibration and the sensor returns to the detection state.

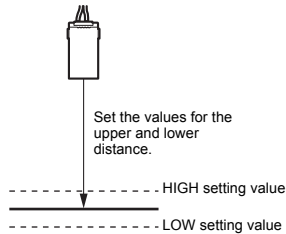

Configuring the sensitivity setting for reference surface (DATUM) detection method

Reference surface (DATUM) calibration (operation mode: F-1, F-2)

This method memorizes the state without a workpiece (reference surface) and use it to perform comparator output when the state differs from the reference surface (when there is a workpiece).

1 Press the [SET] button once without a workpiece in place.

2 Press and hold the [SET] button for at least three seconds without the workpiece in place.

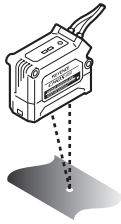

When performing reference surface calibration, the values are set for slightly above and slightly below the reference surface. When the detection value falls within this range, comparator output is turned off. When it falls outside of this range, comparator output is turned on.

Operations during F-1 mode

The setting value can be adjusted by using the [Up] and [Down] arrow buttons, but the HIGH and LOW setting values cannot be adjusted individually.

Operations during F-2 mode

The HIGH and LOW setting values can be adjusted individually by using the [Up] and [Down] arrow buttons.

Note

- Reference surface calibration cannot be used during the following states. (Instead, 2-point calibration is performed.)
 - The spot reflection indicator (1spot) is flashing on the sensor head or sensor amplifier.
 - The setting is control output 2.
 - A mode other than F-1 mode or F-2 mode is being used.
- Reference surface calibration can only be set when the operation mode is F-1 or F-2.
- When performing reference surface calibration, the current value is set to 0.

Clearing reference surface (DATUM) detection method

When the reference surface (DATUM) detection indicator is lit, press and hold the [Up] and [Down] arrow buttons for at least three seconds. The reference surface (DATUM) detection indicator turns off and the sensor returns to distance detection method.

The value is canceled if a form of calibration other than reference surface calibration.

Other Settings

Zero point positioning

Sets the current value to zero (shift target value).

1 Press the [Up] and [Down] arrow buttons simultaneously without a workpiece in place.

The current value becomes "0" and zero point positioning is complete.

Note

When the shift target value is set, performing zero point positioning does not make the current value "0". Instead, it becomes the set value for the shift target value. For more information about setting the shift target value, see page 9 of this Instruction Manual.

Reference

Pressing the [Up] and [Down] arrow buttons simultaneously for at least three seconds cancels the zero point (shift target value).

Initial reset (initialization) and custom save function

Initial reset (initialization)

Returns all of the settings to the factory defaults.

1 While pressing the [MODE] button, press the [SET] button five times.

2 Press the [Down] arrow button to display "rSt no".

Reference When "rSt no" is displayed, pressing the [MODE] button returns to the main screen without initializing.

3 Press the [Up] or [Down] arrow button to select "rSt ini", and then press the [MODE] button to initialize.

Custom save (Saving the settings)

Saves all of the settings. The saved settings can be loaded at a later time.

1 While pressing the [MODE] button, press the [SET] button five times.

2 Press the [Left] or [Right] arrow button to display "SAv".

3 Press the [Down] arrow button to display "SAv no".

Reference When "SAv no" is displayed, pressing the [MODE] button returns to the main screen without saving the settings.

4 Press the [Up] or [Down] arrow button to select "Sav YES", and then press the [MODE] button to save the settings.

Note

Performing custom save overwrites the settings from the previous custom save.

Custom reset (Loading the settings)

Loads the settings saved with custom save.

1 While pressing the [MODE] button, press the [SET] button five times.

2 Press the [Down] arrow button to display "rSt no".

Reference When "rSt no" is displayed, pressing the [MODE] button returns to the main screen without performing custom reset.

3 Press the [Up] or [Down] arrow button to select "rSt CSt", and then press the [MODE] button to load the settings.

Note

Performing custom reset erases the current settings.

Bank switching

The bank function allows two patterns of sensitivity settings to be saved in channels 1 and 2. (This is useful during operations such as switching the setup.)

- The bank switching function can only be used when the external input is set to "bnk" in the OPTIONAL settings.
- Hold down the [MODE] button during main screen and press the [Up] arrow button to switch banks, which allows the settings to be configured for each bank.
- During the keylock state, the banks are switched with external input.

Note

When the external input is off, bank A is used. When the external input is on, bank B is used.

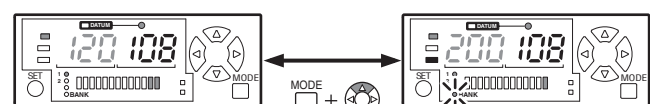

Bank A is in use : Bank indicator is off

Bank B is in use : Bank indicator is on

Keylock Function

The keylock function prevents accidental operation of the buttons during detection. While using the keylock function, operations other than switching the display for the main screen are prohibited.

Note The keylock settings can only be set in the main screen.

Setting/releasing keylock

While pressing the [MODE] button in the main screen, press and hold the [UP] or [Down] button for at least three seconds. This sets (or releases) keylock and returns the sensor to the main screen.

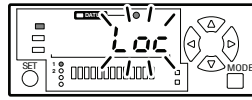

During keylock

Interference protection function

The GV Series can prevent mutual interference that may occur when connecting several expansion units. The interference protection function only works when the following conditions are met.

- Interference protection functions on up to two adjacent units.
- The main unit and expansion units use the same response speed.
- The response speed is set to 1.5, 3, or 10.

Setting Each Type of Function

Press and hold the [MODE] button for at least three seconds in the main screen (during detection) to change the settings.

Note The screen shown to the right is displayed during keylock and basic settings cannot be input.

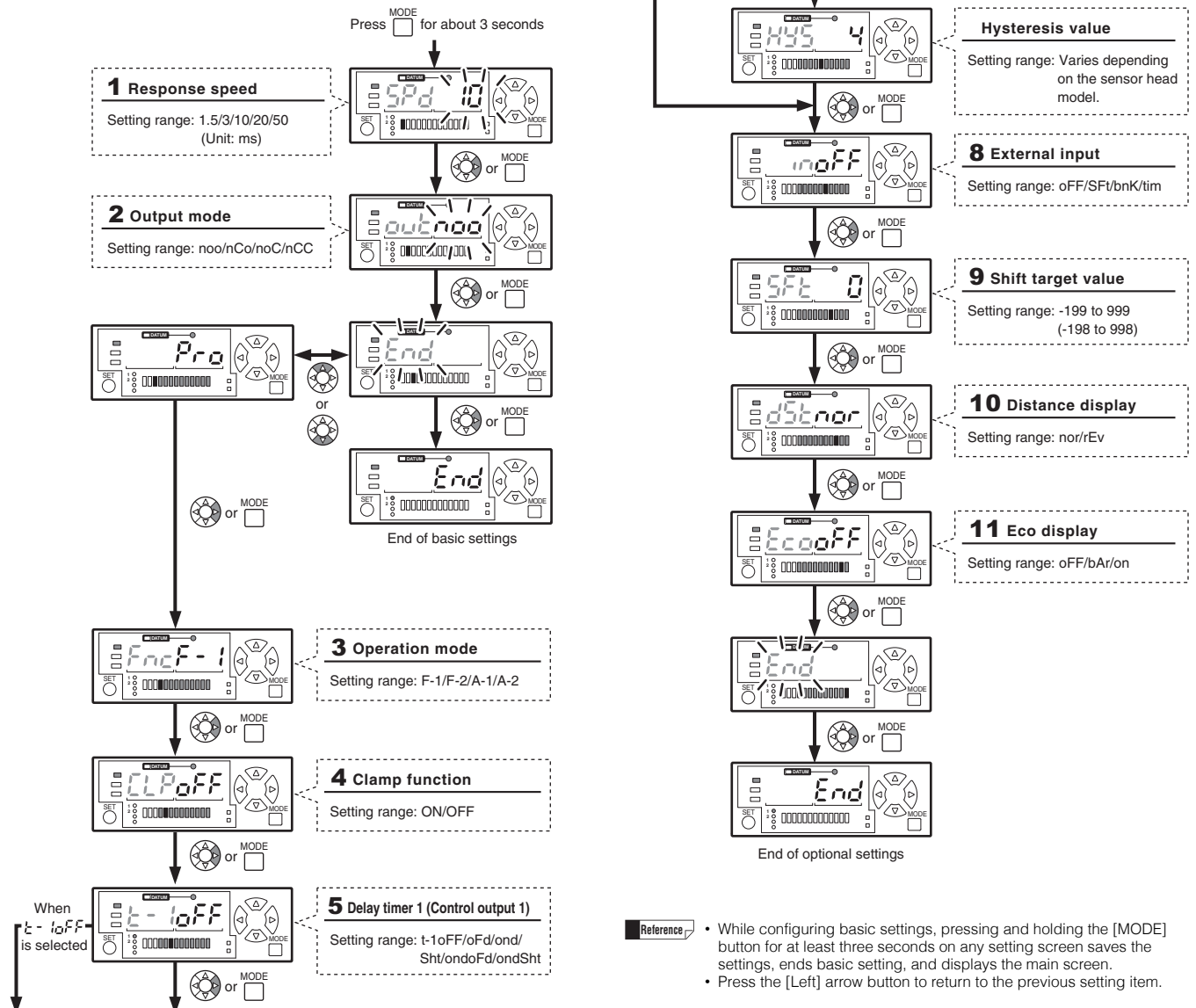

Reference

- While configuring basic settings, pressing and holding the [MODE] button for at least three seconds on any setting screen saves the settings, ends basic setting, and displays the main screen.
- Press the [Left] arrow button to return to the previous setting item.

1. Response speed setting

The response speed is the time from when the sensor head starts detection until the value at the detection position is established as a comparator value.

Item	Setting range	Default value
Response speed	1.5/3/10/20/50 (Unit: ms)	10*

* "20" for GV-H1000 (L) only.

2. Output mode setting

Sets the control output mode for each control output.

Item	Description			Default value
	Settings	Control output 1	Control output 2	
Output mode	noo	N.O.	N.O.	noo
	nCo	N.C.	N.O.	
	noC	N.O.	N.C.	
	nCC	N.C.	N.C.	

Reference N.O. (normal open) and N.C. (normal close) operate in the following manner.

Output mode	During detection
N.O. (normal open)	ON
N.C. (normal close)	OFF

3. Operation mode selection

Sets the operation mode.

Operation mode	Description	Default value
F-1	General Normal detection mode	<input type="radio"/>
F-2	Area detection mode	<input type="radio"/>
A-1	Special Edge hold mode	<input type="radio"/>
A-2	Surface detection mode	<input type="radio"/>

4. Clamp function setting

Set the operations when distance detection cannot be performed (such as when the detection object does not enter the detection range, or when there is insufficient light intensity).

Setting item	Description	Default value
on	Outputs the comparator output with the detection value obtained immediately before the distance was judged to be not detectable. The current value display and LED bar display are also saved for the immediately preceding value. If distance detection can be performed, then the hold is released.	<input type="radio"/>
oFF	When the distance detection cannot be performed and "----" is displayed, the comparator output operates in the same way as if a detection object appears at the farthest point of the detection range.	<input type="radio"/>

5. (6.) Delay timer setting

Individual delay timers can be set for channels 1 and 2.

Setting item	Description	Default value
oFF	Delay timer is not used	<input type="radio"/>
ond	On-delay	<input type="radio"/>
oFd	Off-delay	<input type="radio"/>
Sht	One-shot	<input type="radio"/>
ondoFd	On-delay/off-delay	<input type="radio"/>
ondSht	On-delay/one-shot	<input type="radio"/>

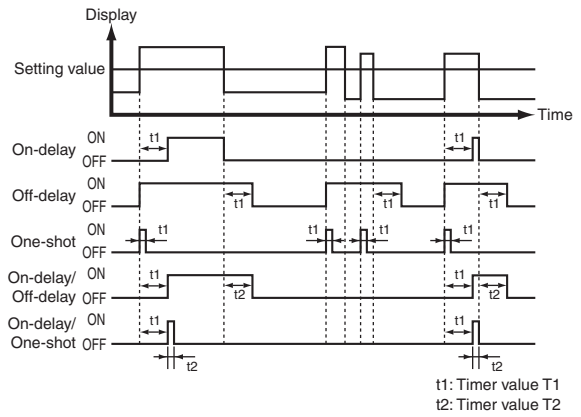

7. Hysteresis setting

Sets the hysteresis for judgment with control outputs 1 and 2.

Setting item	Description	Default value
Std	Run with the default values.	<input type="radio"/>
Usr	Set custom values.	<input type="radio"/>

The hysteresis setting range and default value are as follows when "Usr" is selected.

Head model	Setting range	Default value
GV-H45 (L)	0, 1 to 100	2
GV-H130 (L)	0, 2 to 100	4
GV-H450 (L)	0, 0.5, 1 to 100	0.5
GV-H1000 (L)	0, 1 to 100	5

8. External input function setting

Sets the function assigned to the external input (pink line).

Setting item	Description	Default value
oFF	Do not use external input (input off).	<input type="radio"/>
SFt	Used as "External shift input".	<input type="radio"/>
bnK	Used as "Bank switching input".	<input type="radio"/>
tim	Used as "Timing input".	<input type="radio"/>

Reference The minimum external input time is 20 ms.

External shift input

When external input is input, the current value is shifted by the value set for shift target value. (For information about the shift target value, see "9. Shift target value setting".)

Bank switching input

When keylock is set for the amplifier, the bank switches with input to the external input. (For more information about bank switching, see "Bank switching".)

Note

When edge hold mode (A-1 mode) is set, switching banks with the external input resets the current value to 0.

Timing input

Comparator output is only output over control output 1 when external input is on. The timing input indicator on the sensor amplifier lights up.

Reference Control output 2 continues to output comparator output, regardless of whether timing input is on or off.

9. Setting the shift target value

Set this value to shift the current value by another amount.

Item	Setting range	Default value
Shift target value	-199 to 999	0

- Press the [Up] and [Down] arrow buttons simultaneously to shift the current value to the set value with the shift target value. The shift status is retained even if the power is turned off.

Reference Press the [Up] and [Down] arrow buttons simultaneously and hold them to clear the shifted target value.

- The amplifier does not retain the amount of shift when shifting with external input. (It is cleared when the power is turned off.) To retain the amount of shift, press the [Up] and [Down] arrow buttons simultaneously and perform shift.
- When performing reference surface calibration while edge hold mode (A-1 mode) is set, the value is always shifted to 0.
- Shift is only a effective on the selected bank.

10. Distance display setting

Sets whether to use the sign close to the sensor head as the positive direction (normal) or negative direction (reverse).





Setting item	Description	Default value
nor (Normal)	The display value increases as the target comes closer to the sensor head.	○
rEv (Reverse)	The display value decreases as the target comes closer to the sensor head.	

11. Eco display setting

Set this parameter to reduce the consumption current or to stop displaying specific values. When running in power saving (eco) mode, pressing any button returns the sensor to normal operations. The main screen switches to eco mode if no operations take place for 30 seconds.

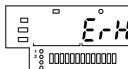
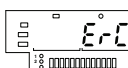
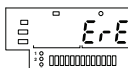
Setting item	Description	Default value
oFF	Turns off the eco display.	○
bAr	Turns off the digital display.	
on	The digital display (green) flashes in sequence. Bar display and channel No. indicators are turned off.	

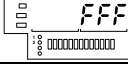
Error Displays and Corrective Actions

Error indication	Error contents	Remedy
 Head error	Sensor head is not connected. Head cable is broken. Sensor head is damaged	<ul style="list-style-type: none"> Check that the sensor head is connected. Check that the head cable is not broken. Check the connection of the head cable to the connector. After checking these points, turn on the power again.
 Overcurrent error	Overcurrent is flowing through the output wire	<ul style="list-style-type: none"> Check the load and reduce the current to be within the rated range. Check that the output wire does not touch another wire or a frame.
 EEPROM error	Data read/write error Data has been written in the EEPROM over 1 million times and can no longer be updated.	Perform initialization. If you need to write more data, replace the amplifier unit.
 No workpiece or background within the detection distance range, or no light is entering the receiver.	There is no workpiece or background within the detection distance range, or no light is entering the receiver.	Set a workpiece or background in the distance for detection from the sensor.
 Reading exceeds the detection distance range.	Reading exceeds the detection distance range.	Set a workpiece or background in the distance for detection from the sensor.
 Light intensity is saturated.	Light intensity is saturated.	Tilt the sensor head so that specular reflection does not enter the sensor.

Troubleshooting

Problem	Cause and solutions
The current value is larger than the setting value, but the output is not reversed.	This type of problem sometimes occurs when multiple reflection occurs while using the distance detecting method. If this problem occurs, use the reference surface detection (DATUM) method and configure the sensitivity setting. If multiple reflection occurs, the spot reflection (1spot) indicator turns off. <ul style="list-style-type: none"> "Distance detection method (Normal)" (page 4) "Reference surface detection (DATUM) method (Application)" (page 5) "Sensor amplifier part names" (page 3)
The external input does not function.	Check the settings for the external input. <ul style="list-style-type: none"> "8. External input function setting" (page 8)
The current settings can no longer be determined. The user wants to return the unit to the factory defaults.	Perform initial reset (initialization). <ul style="list-style-type: none"> "Initial reset (initialization) and custom save function" (page 6)

I/O Circuit Diagram

Output circuit

GV-21/22 (NPN output)

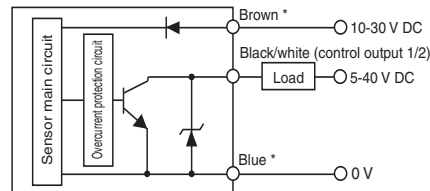

* GV-21 only

GV-21P/22P (PNP output)

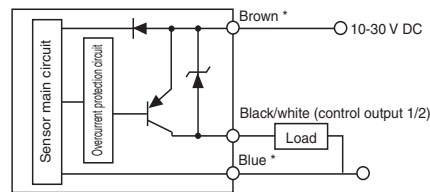

* GV-21P only

Power is supplied to the expansion unit GV-22(P) from the expansion connector on the back of the main unit GV-21(P). The power wires (brown and blue) of the main unit and those of the expansion unit are common inside through the connector.

Input circuit

GV-21/22 (NPN output)

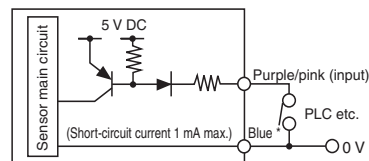

* GV-21 only

GV-21P/22P (PNP output)

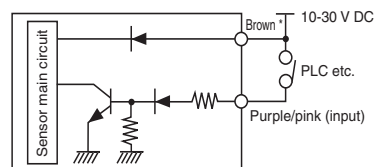

* GV-21P only

Purple line Laser emission stop input
Pink line External input function

* The external input function can be set to one of the following.

- Not used
- Shift input
- Bank switching input
- Timing input

Specifications

■ Sensor head

Item		Specifications							
Model		GV-H45	GV-H45L	GV-H130	GV-H130L	GV-H450	GV-H450L	GV-H1000	GV-H1000L
		Short-range		Mid-range		Long-range		Super-Long-range	
Light source		Visible semiconductor laser Wavelength: 655 nm							
FDA (CDRH) Part 1040.10	Laser Class	Class II	Class 1 ^{*5}	Class II	Class 1 ^{*5}	Class II	Class 1 ^{*5}	Class II	Class 1 ^{*5}
	Output	560μW	220μW	560μW	220μW	560μW	220μW	560μW	220μW
IEC 60825-1	Laser Class	Class 2	Class 1	Class 2	Class 1	Class 2	Class 1	Class 2	Class 1
	Output	560μW	220μW	560μW	220μW	560μW	220μW	560μW	220μW
Detection distance (Amplifier display value ^{*1})		20 to 45 mm (250 to 0)		55 to 130 mm (750 to 0)		160 to 450 mm (290 to 0)		200 to 1000 mm (800 to 0)	
Amplifier display range		259 to -34		768 to -98		295 to -50		810 to -175	
Standard detection deviation		0.5 mm		1 mm		3 mm		20 mm (Detection distance 200 to 800 mm), 30 mm (Detection distance 800 to 1000 mm)	
Spot diameter		Approx. φ0.1 mm (Detection distance 45 mm)		Approx. φ0.3 mm (Detection distance 130 mm)		Approx. φ0.8 mm (Detection distance 450 mm)		Approx. φ1.8 mm (Detection distance 1000 mm)	
Operation status indicators		Control output: Laser radiation emission indicator: Other:				Red LED Green LED Green LED			
Environmental resistance	Enclosure rating	IP67							
	Surrounding air temperature	-10 to +50°C (No freezing)							
	Relative humidity	35 to 85% RH (No condensation)							
	Surrounding light	Incandescent lamp	10,000 lx	5,000 lx	10,000 lx	5,000 lx	5,000 lx	2,500 lx	5,000 ² lx
	Sunlight	20,000 lx	10,000 lx	20,000 lx	10,000 lx	10,000 lx	5,000 lx	10,000 ² lx	5,000 ³ lx
	Vibration	10 to 55 Hz, 1.5 mm double amplitude in the X, Y, and Z directions, 2 hours respectively							
Material	Housing	Housing material: PBT				Packing: NBR			
	Lens cover	Display: Polyarylate				Metal part: SUS304			
	Cable	Glass							
Cable length		2 m						3 m	
Weight ^{*4}		Approx. 120 g		Approx. 130 g		Approx. 190 g		Approx. 210 g	

- *1 Guideline of the amplifier display value when the distance display for the detection distance is set to "nor".
 *2 For GV-H1000, when the response speed is set to 10 ms or less, Incandescent lamp: 5,000 lx, Sunlight: 3,000 lx
 *3 For GV-H1000L, when the response speed is set to 10 ms or less, Incandescent lamp: 2,500 lx, Sunlight: 1,500 lx
 *4 Including the connector cable.
 *5 The laser classification for FDA(CDRH) is implemented based on IEC60825-1 in accordance with the requirements of Laser Notice No.50.

■ Sensor amplifier

Item		Specifications	
Model	NPN output	GV-21	GV-22
	PNP output	GV-21P	GV-22P
Amplifier type		Main unit	Expansion unit
Power voltage ^{*1}		10-30 VDC, Ripple (P-P): 10% max, Class 2	
Power consumption		Normal: 2200 mW max. (at 30 V: 73.3 mA max.) Eco-bar: 1700 mW max. (at 30 V: 56.7 mA max.) Eco-all: 1600 mW max. (at 30 V: 53.3 mA max.)	
Response time		1.5/3/10/20/50 ms	
Control output		NPN (PNP) open collector x 2ch, 40 V (30 V) DC max. Max. 100 mA, residual voltage 1 V max.	
Control input		Purple line Laser emission stop input Pink line Setting value bank switching input/ shift input/timing input (selected with the settings)	
Environmental resistance	Surrounding air temperature	-10 to +55°C (No freezing)	
	Relative humidity	35 to 85% RH (No condensation)	
	Vibration	10 to 55 Hz, 1.5 mm double amplitude in the X, Y, and Z directions, 2 hours respectively	
Material		Housing material, front sheet: Polycarbonate Key top: Polyacetal Cable: PVC	
Weight ^{*2}		Approx. 110 g	

- *1 11 to 30 VDC when amplifiers are extended.
 *2 Including the cable (2 m).

WARRANTIES AND DISCLAIMERS

- (1) KEYENCE warrants the Products to be free of defects in materials and workmanship for a period of one (1) year from the date of shipment. If any models or samples were shown to Buyer, such models or samples were used merely to illustrate the general type and quality of the Products and not to represent that the Products would necessarily conform to said models or samples. Any Products found to be defective must be shipped to KEYENCE with all shipping costs paid by Buyer or offered to KEYENCE for inspection and examination. Upon examination by KEYENCE, KEYENCE, at its sole option, will refund the purchase price of, or repair or replace at no charge any Products found to be defective. This warranty does not apply to any defects resulting from any action of Buyer, including but not limited to improper installation, improper interfacing, improper repair, unauthorized modification, misapplication and mishandling, such as exposure to excessive current, heat, coldness, moisture, vibration or outdoors air. Components which wear are not warranted.
- (2) KEYENCE is pleased to offer suggestions on the use of its various Products. They are only suggestions, and it is Buyer's responsibility to ascertain the fitness of the Products for Buyer's intended use. KEYENCE will not be responsible for any damages that may result from the use of the Products.
- (3) The Products and any samples ("Products/Samples") supplied to Buyer are not to be used internally in humans, for human transportation, as safety devices or fail-safe systems, unless their written specifications state otherwise. Should any Products/Samples be used in such a manner or misused in any way, KEYENCE assumes no responsibility, and additionally Buyer will indemnify KEYENCE and hold KEYENCE harmless from any liability or damage whatsoever arising out of any misuse of the Products/Samples.
- (4) **OTHER THAN AS STATED HEREIN, THE PRODUCTS/SAMPLES ARE PROVIDED WITH NO OTHER WARRANTIES WHATSOEVER. ALL EXPRESS, IMPLIED, AND STATUTORY WARRANTIES, INCLUDING, WITHOUT LIMITATION, THE WARRANTIES OF MERCHANTABILITY, FITNESS FOR A PARTICULAR PURPOSE, AND NON-INFRINGEMENT OF PROPRIETARY RIGHTS, ARE EXPRESSLY DISCLAIMED. IN NO EVENT SHALL KEYENCE AND ITS AFFILIATED ENTITIES BE LIABLE TO ANY PERSON OR ENTITY FOR ANY DIRECT, INDIRECT, INCIDENTAL, PUNITIVE, SPECIAL OR CONSEQUENTIAL DAMAGES (INCLUDING, WITHOUT LIMITATION, ANY DAMAGES RESULTING FROM LOSS OF USE, BUSINESS INTERRUPTION, LOSS OF INFORMATION, LOSS OR INACCURACY OF DATA, LOSS OF PROFITS, LOSS OF SAVINGS, THE COST OF PROCUREMENT OF SUBSTITUTED GOODS, SERVICES OR TECHNOLOGIES, OR FOR ANY MATTER ARISING OUT OF OR IN CONNECTION WITH THE USE OR INABILITY TO USE THE PRODUCTS, EVEN IF KEYENCE OR ONE OF ITS AFFILIATED ENTITIES WAS ADVISED OF A POSSIBLE THIRD PARTY'S CLAIM FOR DAMAGES OR ANY OTHER CLAIM AGAINST BUYER.** In some jurisdictions, some of the foregoing warranty disclaimers or damage limitations may not apply.

BUYER'S TRANSFER OBLIGATIONS:

If the Products/Samples purchased by Buyer are to be resold or delivered to a third party, Buyer must provide such third party with a copy of this document, all specifications, manuals, catalogs, leaflets and written information provided to Buyer pertaining to the Products/Samples.

E 1101-3

KEYENCE CORPORATION

1-3-14, Higashi-Nakajima, Higashi-Yodogawa-ku,
Osaka, 533-8555, Japan
PHONE: +81-6-6379-2211

www.keyence.com

AUSTRIA Ph: +43 22 36-3782 66-0	HONG KONG Ph: +852-3104-1010	NETHERLANDS Ph: +31 40 20 66 100	THAILAND Ph: +66-2-369-2777
BELGIUM Ph: +32 1 528 1222	HUNGARY Ph: +36 1 802 73 60	POLAND Ph: +48 71 36861 60	UK & IRELAND Ph: +44-1908-696900
BRAZIL Ph: +55-11-3045-4011	INDIA Ph: +91-44-4963-0900	ROMANIA Ph: +40 269-232-808	USA Ph: +1-201-930-0100
CANADA Ph: +1-905-366-7655	INDONESIA Ph: +62-21-2966-0120	SINGAPORE Ph: +65-6392-1011	VIETNAM Ph: +84-4-3772-5555
CHINA Ph: +86-21-3357-1001	ITALY Ph: +39-02-6688220	SLOVAKIA Ph: +41 2 5939 6461	
CZECH REPUBLIC Ph: +420 222 191 483	KOREA Ph: +82-31-789-4300	SLOVENIA Ph: +386 1-4701-666	
FRANCE Ph: +33 1 56 37 78 00	MALAYSIA Ph: +60-3-7883-2211	SWITZERLAND Ph: +41 43-45577 30	
GERMANY Ph: +49 6102 36 89-0	MEXICO Ph: +52-55-8850-0100	TAIWAN Ph: +886-2-2721-8080	

Specifications are subject to change without notice.

A6WW1-MAN-1086

Copyright (c) 2011 KEYENCE CORPORATION. All rights reserved.
11664E 1116-4 [96M11664] Printed in Japan

