



**EMERSON**<sup>™</sup>  
Industrial Automation



## *User Guide*

---

# ***Unidrive M100/101***

---

*Model size 1 to 4*

Variable Speed AC drive for induction motors

Part Number: 0478-0041-03

Issue: 3



[www.controltechniques.com](http://www.controltechniques.com)

## General information

The manufacturer accepts no liability for any consequences resulting from inappropriate, negligent or incorrect installation or adjustment of the optional operating parameters of the equipment or from mismatching the variable speed drive with the motor.

The contents of this guide are believed to be correct at the time of printing. In the interests of a commitment to a policy of continuous development and improvement, the manufacturer reserves the right to change the specification of the product or its performance, or the contents of the guide, without notice.

All rights reserved. No parts of this guide may be reproduced or transmitted in any form or by any means, electrical or mechanical including photocopying, recording or by an information storage or retrieval system, without permission in writing from the publisher.

## Drive firmware version

This product is supplied with the latest firmware version. If this drive is to be connected to an existing system or machine, all drive firmware versions should be verified to confirm the same functionality as drives of the same model already present. This may also apply to drives returned from a Control Techniques Service Centre or Repair Centre. If there is any doubt please contact the supplier of the product.

The firmware version of the drive can be checked by looking at Pr **11.029**.

## Environmental statement

Control Techniques is committed to minimising the environmental impacts of its manufacturing operations and of its products throughout their life cycle. To this end, we operate an Environmental Management System (EMS) which is certified to the International Standard ISO 14001. Further information on the EMS, our Environmental Policy and other relevant information is available on request, or can be found at [www.greendrives.com](http://www.greendrives.com).

The electronic variable-speed drives manufactured by Control Techniques have the potential to save energy and (through increased machine/process efficiency) reduce raw material consumption and scrap throughout their long working lifetime. In typical applications, these positive environmental effects far outweigh the negative impacts of product manufacture and end-of-life disposal.

Nevertheless, when the products eventually reach the end of their useful life, they must not be discarded but should instead be recycled by a specialist recycler of electronic equipment. Recyclers will find the products easy to dismantle into their major component parts for efficient recycling. Many parts snap together and can be separated without the use of tools, while other parts are secured with conventional fasteners. Virtually all parts of the product are suitable for recycling.

Product packaging is of good quality and can be re-used. Large products are packed in wooden crates, while smaller products come in strong cardboard cartons which themselves have a high recycled fibre content. If not re-used, these containers can be recycled. Polythene, used on the protective film and bags for wrapping product, can be recycled in the same way. Control Techniques' packaging strategy prefers easily-recyclable materials of low environmental impact, and regular reviews identify opportunities for improvement.

When preparing to recycle or dispose of any product or packaging, please observe local legislation and best practice.

## REACH legislation

EC Regulation 1907/2006 on the Registration, Evaluation, Authorisation and restriction of Chemicals (REACH) requires the supplier of an article to inform the recipient if it contains more than a specified proportion of any substance which is considered by the European Chemicals Agency (ECHA) to be a Substance of Very High Concern (SVHC) and is therefore listed by them as a candidate for compulsory authorisation.

For current information on how this requirement applies in relation to specific Control Techniques products, please approach your usual contact in the first instance. Control Techniques position statement can be viewed at: <http://www.controltechniques.com/REACH>

Copyright © February 2014 Control Techniques Ltd

Issue Number: 3

Drive Firmware: 01.03.00 onwards

For patent and intellectual property related information please go to: [www.ctpatents.info](http://www.ctpatents.info)

# How to use this guide

This user guide provides complete information for installing and operating the drive from start to finish.

The information is in logical order, taking the reader from receiving the drive through to fine tuning the performance.

## NOTE

There are specific safety warnings throughout this guide, located in the relevant sections. In addition, Chapter 1 *Safety information* contains general safety information. It is essential that the warnings are observed and the information considered when working with or designing a system using the drive.

This map of the user guide helps to find the right sections for the task you wish to complete, but for specific information, refer to *Contents* on page 4:

	Quick Start / bench testing	Familiarisation	System design	Programming and commissioning	Troubleshooting
1 Safety information	●	●	●	●	●
2 Product information		●	●		
3 Mechanical installation			●		
4 Electrical installation			●		
5 Getting started		●	●		
6 Basic parameters		●	●	●	
7 Running the motor	●	●	●	●	
8 Optimization			●	●	
9 NV Media card operation			●	●	
10 Advanced parameters			●	●	
11 Technical data		●	●	●	
12 Diagnostics					●
13 UL listing information			●	●	

# Contents

<b>1</b>	<b>Safety information</b>	<b>7</b>	<b>5</b>	<b>Getting started</b>	<b>50</b>
1.1	Warnings, Cautions and Notes	7	5.1	Understanding the display	50
1.2	Electrical safety - general warning	7	5.2	Keypad operation	50
1.3	System design and safety of personnel	7	5.3	Menu structure	52
1.4	Environmental limits	7	5.4	Menu 0	52
1.5	Access	7	5.5	Advanced menus	53
1.6	Fire protection	7	5.6	Saving parameters	53
1.7	Compliance with regulations	7	5.7	Restoring parameter defaults	53
1.8	Motor	7	5.8	Parameter access level and security	54
1.9	Adjusting parameters	7	5.9	Displaying parameters with non-default values only	54
1.10	Electrical installation	8	5.10	Displaying destination parameters only	54
1.11	Hazard	8			
<b>2</b>	<b>Product information</b>	<b>9</b>	<b>6</b>	<b>Basic parameters</b>	<b>55</b>
2.1	Model number	9	6.1	Menu 0: Basic parameters	55
2.2	Ratings	10	6.2	Parameter descriptions	58
2.3	Operating modes	12			
2.4	Drive features	13	<b>7</b>	<b>Running the motor</b>	<b>59</b>
2.5	Keypad and display	14	7.1	Quick start connections	59
2.6	Nameplate description	14	7.2	Quick start commissioning / start-up	61
2.7	Options	15			
2.8	Items supplied with the drive	16	<b>8</b>	<b>Optimization</b>	<b>62</b>
<b>3</b>	<b>Mechanical installation</b>	<b>17</b>	8.1	Motor map parameters	62
3.1	Safety information	17	8.2	Maximum motor rated current	65
3.2	Planning the installation	17	8.3	Current limits	65
3.3	Terminal cover removal	18	8.4	Motor thermal protection	65
3.4	Installing / removing option	19	8.5	Switching frequency	65
3.5	Dimensions and mounting methods	20			
3.6	Enclosure for standard drives	23	<b>9</b>	<b>NV Media Card</b>	<b>67</b>
3.7	Enclosure design and drive ambient temperature	25	9.1	Introduction	67
3.8	Heatsink fan operation	25	9.2	SD card support	67
3.9	External EMC filter	26	9.3	NV Media Card parameters	68
3.10	Electrical terminals	28	9.4	NV Media Card trips	68
3.11	Routine maintenance	29			
<b>4</b>	<b>Electrical installation</b>	<b>30</b>	<b>10</b>	<b>Advanced parameters</b>	<b>69</b>
4.1	Power connections	30	10.1	Menu 1: Frequency reference	76
4.2	AC supply requirements	33	10.2	Menu 2: Ramps	80
4.3	Ratings	33	10.3	Menu 3: Frequency control	83
4.4	Output circuit and motor protection	36	10.4	Menu 4: Torque and current control	85
4.5	Braking	39	10.5	Menu 5: Motor control	87
4.6	Ground leakage	40	10.6	Menu 6: Sequencer and clock	89
4.7	EMC (Electromagnetic compatibility)	41	10.7	Menu 7: Analog I/O	92
4.8	Control connections	47	10.8	Menu 8: Digital I/O	94
			10.9	Menu 10: Status and trips	98
			10.10	Menu 11: General drive set-up	100
			10.11	Menu 22: Additional Menu 0 set-up	101
			<b>11</b>	<b>Technical data</b>	<b>103</b>
			11.1	Drive technical data	103
			11.2	Optional external EMC filters	114

<b>12</b>	<b>Diagnostics</b>	<b>116</b>
12.1	Status modes	116
12.2	Trip indications	116
12.3	Identifying a trip / trip source	116
12.4	Trips, Sub-trip numbers	117
12.5	Internal / Hardware trips	129
12.6	Alarm indications	129
12.7	Status indications	130
12.8	Displaying the trip history	130
12.9	Behavior of the drive when tripped	131
<b>13</b>	<b>UL Listing</b>	<b>132</b>
13.1	General	132
13.2	Mounting	132
13.3	Environment	132
13.4	Electrical installation	132
13.5	UL listed accessories	132
13.6	Motor overload protection	132
13.7	Motor overspeed protection	132
13.8	Thermal memory retention	132
13.9	Electrical ratings	132
13.10	cUL requirements for frame size 4	132
13.11	Group installation	132

# Declaration of Conformity

**Control Techniques Ltd**  
**The Gro**  
**Newtown**  
**Powys**  
**UK**  
**SY16 3BE**

**Moteurs Leroy-Somer**  
**Usine des Agriers**  
**Boulevard Marcellin Leroy**  
**CS10015**  
**16915 Angoulême Cedex 9**  
**France**

This declaration applies to Unidrive M variable speed drive products, comprising models numbers as shown below:

These products comply with the Low Voltage Directive 2006/95/EC and the Electromagnetic Compatibility Directive 2004/108/EC.

<b>Maaa-bbcdddd</b> Valid characters:	
<i>aaa</i>	100, 101, 200, 201, 300, 400
<i>bb</i>	01, 02, 03
<i>c</i>	1,2 or 4
<i>dddd</i>	00013, 00017, 00018, 00023, 00024, 00032, 00033, 00041, 00042, 00056, 00075, 00056, 00073, 00094, 00100



**T. Alexander**  
**Vice President, Technology**  
**Newtown**

The AC variable speed drive products listed above have been designed and manufactured in accordance with the following European harmonized standards:

**Date: 18th December 2013**

EN 61800-5-1:2007	Adjustable speed electrical power drive systems - safety requirements - electrical, thermal and energy
EN 61800-3:2004	Adjustable speed electrical power drive systems. EMC product standard including specific test methods
EN 61000-6-2:2005	Electromagnetic compatibility (EMC). Generic standards. Immunity standard for industrial environments
EN 61000-6-4:2007	Electromagnetic compatibility (EMC). Generic standards. Emission standard for industrial environments
EN 61000-3-2:2006	Electromagnetic compatibility (EMC), Limits, Limits for harmonic current emissions (equipment input current <16 A per phase)
EN 61000-3-3:2008	Electromagnetic compatibility (EMC), Limits, Limitation of voltage fluctuations and flicker in low-voltage supply systems for equipment with rated current <16 A

**These electronic drive products are intended to be used with appropriate motors, controllers, electrical protection components and other equipment to form complete end products or systems. Compliance with safety and EMC regulations depends upon installing and configuring drives correctly, including using the specified input filters. The drives must be installed only by professional assemblers who are familiar with requirements for safety and EMC. The assembler is responsible for ensuring that the end product or system complies with all the relevant laws in the country where it is to be used. Refer to the User Guide. An EMC Data Sheet is also available giving detailed EMC information.**

EN 61000-3-2:2006 Applicable where input current <16 A. No limits apply for professional equipment where input power >1 kW.

# 1 Safety information

## 1.1 Warnings, Cautions and Notes



A Warning contains information which is essential for avoiding a safety hazard.

**WARNING**



A Caution contains information which is necessary for avoiding a risk of damage to the product or other equipment.

**CAUTION**

### NOTE

A Note contains information which helps to ensure correct operation of the product.

## 1.2 Electrical safety - general warning

The voltages used in the drive can cause severe electrical shock and/or burns, and could be lethal. Extreme care is necessary at all times when working with or adjacent to the drive.

Specific warnings are given at the relevant places in this User Guide.

## 1.3 System design and safety of personnel

The drive is intended as a component for professional incorporation into complete equipment or a system. If installed incorrectly, the drive may present a safety hazard.

The drive uses high voltages and currents, carries a high level of stored electrical energy, and is used to control equipment which can cause injury.

Close attention is required to the electrical installation and the system design to avoid hazards either in normal operation or in the event of equipment malfunction. System design, installation, commissioning/start-up and maintenance must be carried out by personnel who have the necessary training and experience. They must read this safety information and this User Guide carefully.

The STOP functions of the drive do not isolate dangerous voltages from the output of the drive or from any external option unit. The supply must be disconnected by an approved electrical isolation device before gaining access to the electrical connections.

**None of the drive functions must be used to ensure safety of personnel, i.e. they must not be used for safety-related functions.**

Careful consideration must be given to the functions of the drive which might result in a hazard, either through their intended behavior or through incorrect operation due to a fault. In any application where a malfunction of the drive or its control system could lead to or allow damage, loss or injury, a risk analysis must be carried out, and where necessary, further measures taken to reduce the risk - for example, an over-speed protection device in case of failure of the speed control, or a fail-safe mechanical brake in case of loss of motor braking.

## 1.4 Environmental limits

Instructions in this User Guide regarding transport, storage, installation and use of the drive must be complied with, including the specified environmental limits. Drives must not be subjected to excessive physical force.

## 1.5 Access

Drive access must be restricted to authorized personnel only. Safety regulations which apply at the place of use must be complied with.

## 1.6 Fire protection

The drive enclosure is not classified as a fire enclosure. A separate fire enclosure must be provided. For further information, refer to section 3.2.5 *Fire protection* on page 17.

## 1.7 Compliance with regulations

The installer is responsible for complying with all relevant regulations, such as national wiring regulations, accident prevention regulations and electromagnetic compatibility (EMC) regulations. Particular attention must be given to the cross-sectional areas of conductors, the selection of fuses or other protection, and protective ground (earth) connections.

This User Guide contains instruction for achieving compliance with specific EMC standards.

Within the European Union, all machinery in which this product is used must comply with the following directives:

2006/42/EC Safety of machinery.

2004/108/EC: Electromagnetic Compatibility.

## 1.8 Motor

Ensure the motor is installed in accordance with the manufacturer's recommendations. Ensure the motor shaft is not exposed.

Standard squirrel cage induction motors are designed for single speed operation. If it is intended to use the capability of the drive to run a motor at speeds above its designed maximum, it is strongly recommended that the manufacturer is consulted first.

Low speeds may cause the motor to overheat because the cooling fan becomes less effective. The motor should be installed with a protection thermistor. If necessary, an electric forced vent fan should be used.

The values of the motor parameters set in the drive affect the protection of the motor. The default values in the drive should not be relied upon.

It is essential that the correct value is entered in Pr **00.006** motor rated current. This affects the thermal protection of the motor.

## 1.9 Adjusting parameters

Some parameters have a profound effect on the operation of the drive. They must not be altered without careful consideration of the impact on the controlled system. Measures must be taken to prevent unwanted changes due to error or tampering.

## 1.10 Electrical installation

### 1.10.1 Electric shock risk

The voltages present in the following locations can cause severe electric shock and may be lethal:

AC supply cables and connections

Output cables and connections

Many internal parts of the drive, and external option units

Unless otherwise indicated, control terminals are single insulated and must not be touched.

### 1.10.2 Stored charge

The drive contains capacitors that remain charged to a potentially lethal voltage after the AC supply has been disconnected. If the drive has been energized, the AC supply must be isolated at least ten minutes before work may continue.

## 1.11 Hazard

### 1.11.1 Falling hazard

The drive presents a falling or toppling hazard. This can still cause injury to personnel and therefore should be handled with care.

Maximum weight:

Size 2: 1.3 kg (3 lb).

Size 3: 1.5 kg (3.3 lb).



## 2 Product information

### 2.1 Model number

The way in which the model numbers for the Unidrive M range are formed is illustrated below:

Figure 2-1 Model number

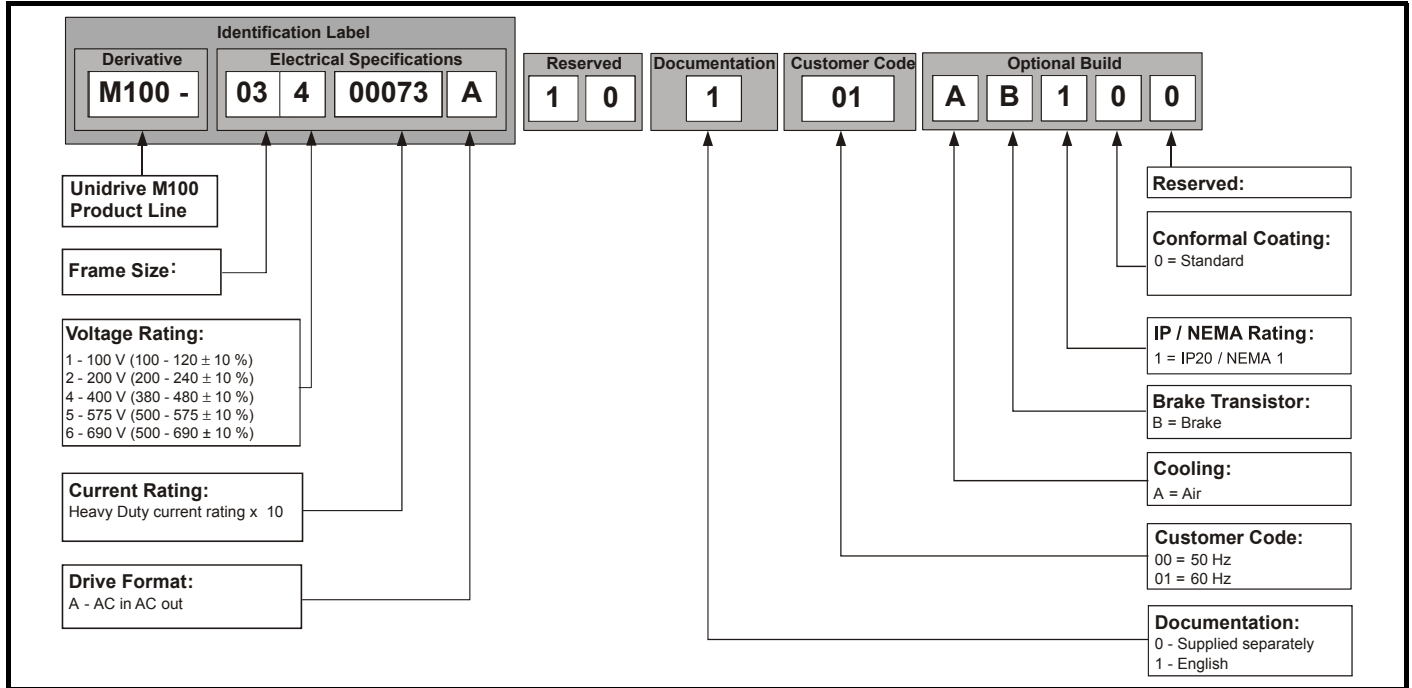

## 2.2 Ratings

The drive is single rated.  
 The rating is compatible with motors designed to IEC60034.  
 The graph on the right illustrates Heavy Duty with respect to continuous current rating and short term overload limits.

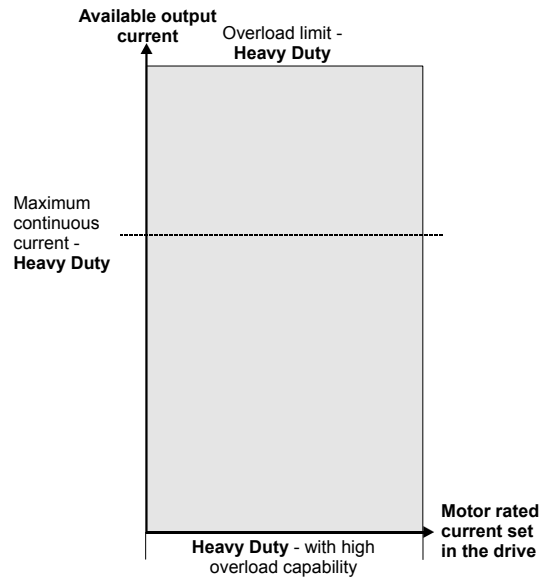

### Heavy Duty

For constant torque applications or applications which require a high overload capability, or full torque is required at low speeds (e.g. winders, hoists).  
 The thermal protection is set to protect force ventilated induction motors by default.

**NOTE**  
 If the application uses a self ventilated (TENV/TEFC) induction motor and increased thermal protection is required for speeds below 50 % base speed, then this can be enabled by setting *Low Speed Thermal Protection Mode* (04.025) = 1.

### Operation of motor I<sup>2</sup>t protection

Motor I<sup>2</sup>t protection is fixed as shown below and is compatible with:

- Self ventilated (TENV/TEFC) induction motors

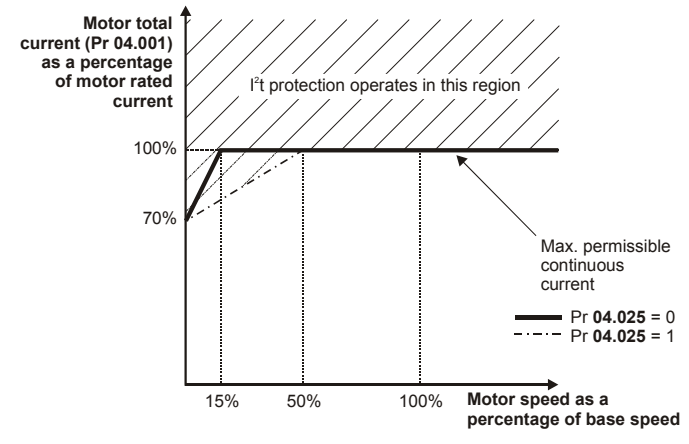

Motor I<sup>2</sup>t protection defaults to be compatible with:

- Forced ventilation induction motors

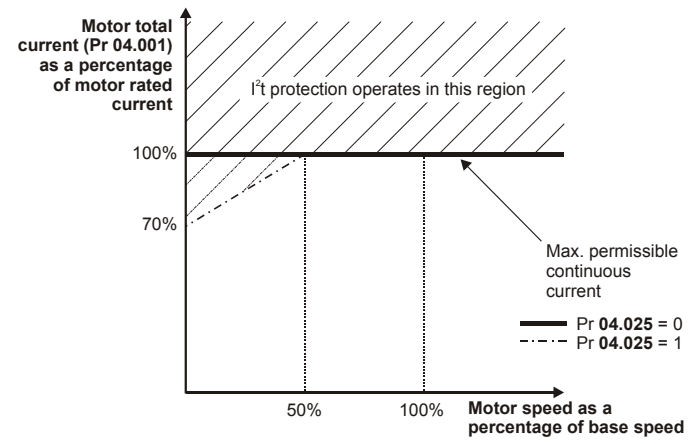

The continuous current ratings given are for maximum 40 °C (104 °F), 1000 m altitude and 3.0 kHz switching. Derating is required for higher switching frequencies, ambient temperature >40 °C (104 °F) and high altitude. For further information, refer to Chapter 11 *Technical data* on page 103.

**Table 2-1 100 V drive ratings (100 V to 120 V ±10 %)**

Model		Heavy Duty			
		Maximum continuous output current	Open loop peak current	Nominal power at 100 V	Motor power at 100 V
		A	A	kW	hp
Frame size 1	01100017	1.7	2.6	0.25	0.33
	01100024	2.4	3.6	0.37	0.5
Frame size 2	02100042	4.2	6.3	0.75	1
	02100056	5.6	8.4	1.1	1.5

**Table 2-2 200 V drive ratings (200 V to 240 V ±10 %)**

Model		Heavy Duty			
		Maximum continuous output current	Open loop peak current	Nominal power at 230 V	Motor power at 230 V
		A	A	kW	hp
Frame size 1	01200017	1.7	2.6	0.25	0.33
	01200024	2.4	3.6	0.37	0.5
	01200033	3.3	5	0.55	0.75
	01200042	4.2	6.3	0.75	1
Frame size 2	02200024	2.4	3.6	0.37	0.5
	02200033	3.3	5	0.55	0.75
	02200042	4.2	6.3	0.75	1
	02200056	5.6	8.4	1.1	1.5
	02200075	7.5	11.3	1.5	2
Frame size 3	03200100	10.0	15	2.2	3
Frame size 4	04200133	13.3	20	3	3
	04200176	17.6	26.4	4	5

**Table 2-3 400 V drive ratings (380 V to 480 V ±10 %)**

Model		Heavy Duty			
		Maximum continuous output current	Open loop peak current	Nominal power at 400 V	Motor power at 400 V
		A	A	kW	hp
Frame size 2	02400013	1.3	2	0.37	0.5
	02400018	1.8	2.7	0.55	0.75
	02400023	2.3	3.5	0.75	1
	02400032	3.2	4.8	1.1	1.5
	02400041	4.1	6.2	1.5	2
Frame size 3	03400056	5.6	8.4	2.2	3
	03400073	7.3	11	3	3
	03400094	9.4	14.1	4	5
Frame size 4	04400135	13.5	20.3	5.5	7.5
	04400170	17.0	25.5	7.5	10

### 2.2.1 Typical short term overload limits

The maximum percentage overload limit changes depending on the selected motor. Variations in motor rated current, motor power factor and motor leakage inductance all result in changes in the maximum possible overload. The exact value for a specific motor can be calculated using the equations detailed in Menu 4 in the *Parameter Reference Guide*.

Typical values are shown in the table below for open loop (OL) modes:

**Table 2-4 Typical overload limits**

Operating mode	Open loop from cold	Open loop from 100 %
Heavy Duty overload with motor rated current = drive rated current	150 % for 60 s	150 % for 8 s

Generally the drive rated current is higher than the matching motor rated current allowing a higher level of overload than the default setting.

The time allowed in the overload region is proportionally reduced at very low output frequency on some drive ratings.

#### NOTE

The maximum overload level which can be attained is independent of the speed.

## 2.3 Operating modes

The drive is designed to operate in any of the following modes:

1. Open loop mode
  - Open loop vector mode
  - Fixed V/F mode (V/Hz)
  - Square V/F mode (V/Hz)

### 2.3.1 Open loop mode

The drive applies power to the motor at frequencies varied by the user. The motor speed is a result of the output frequency of the drive and slip due to the mechanical load. The drive can improve the speed control of the motor by applying slip compensation. The performance at low speed depends on whether V/F mode or open loop vector mode is selected.

#### Open loop vector mode

The voltage applied to the motor is directly proportional to the frequency except at low speed where the drive uses motor parameters to apply the correct voltage to keep the flux constant under varying load conditions.

Typically 100 % torque is available down to 1 Hz for a 50 Hz motor.

#### Fixed V/F mode

The voltage applied to the motor is directly proportional to the frequency except at low speed where a voltage boost is provided which is set by the user. This mode can be used for multi-motor applications.

Typically 100 % torque is available down to 4 Hz for a 50 Hz motor.

#### Square V/F mode

The voltage applied to the motor is directly proportional to the square of the frequency except at low speed where a voltage boost is provided which is set by the user. This mode can be used for running fan or pump applications with quadratic load characteristics or for multi-motor applications. This mode is not suitable for applications requiring a high starting torque.

## 2.4 Drive features

Figure 2-2 Features of the drive

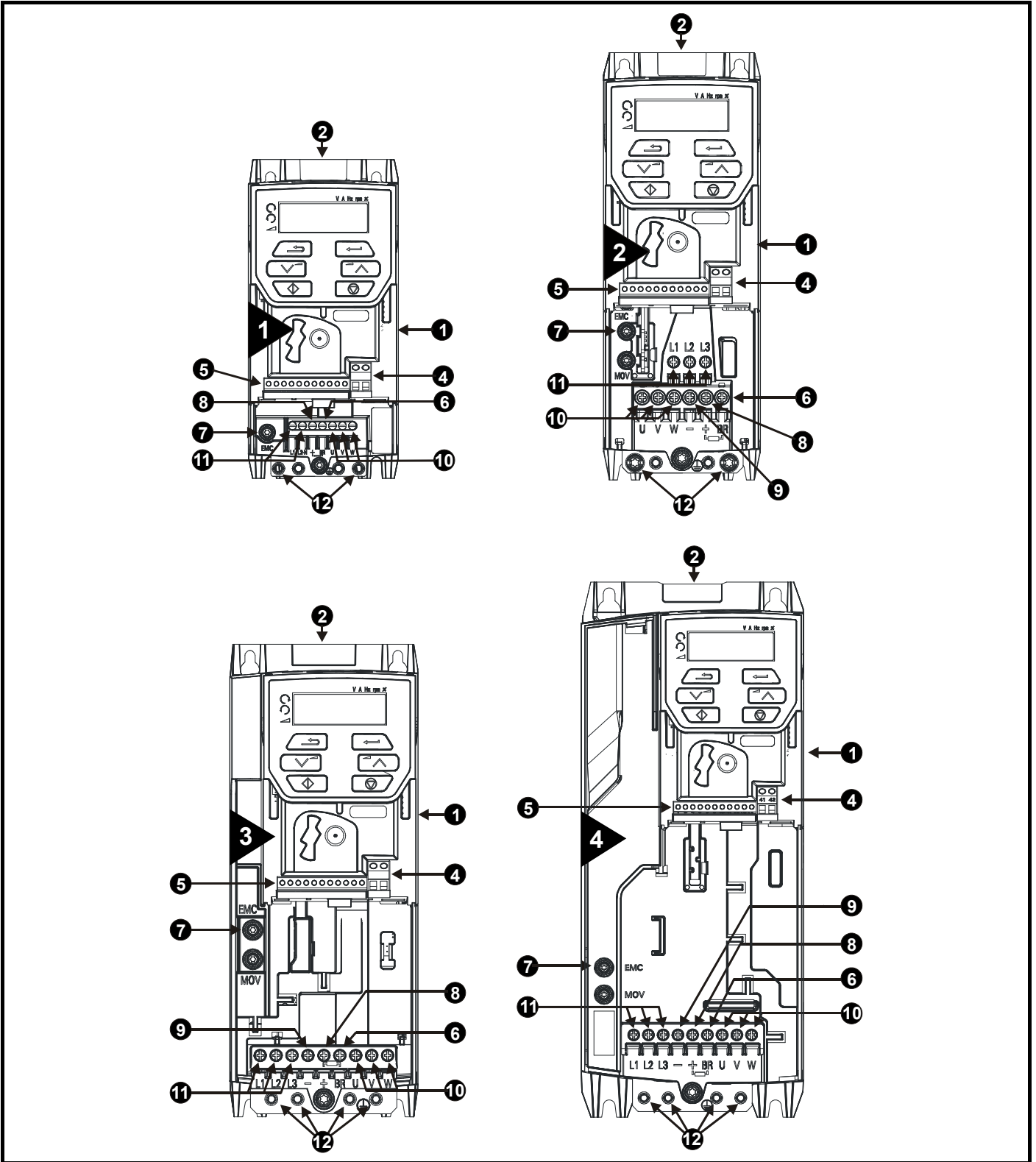

### Key

- |                                    |                              |                           |
|------------------------------------|------------------------------|---------------------------|
| 1. Rating label (On side of drive) | 6. Braking terminal          | 10. Motor connections     |
| 2. Identification label            | 7. Internal EMC filter screw | 11. AC supply connections |
| 4. Relay connections               | 8. DC bus +                  | 12. Ground connections    |
| 5. Control connections             | 9. DC bus -                  |                           |

## 2.5 Keypad and display

The keypad and display provide information to the user regarding the operating status of the drive and trip codes, and provide the means for changing parameters, stopping and starting the drive, and the ability to perform a drive reset.

Figure 2-3 Unidrive M100 keypad detail

Figure 2-4 Unidrive M101 keypad detail

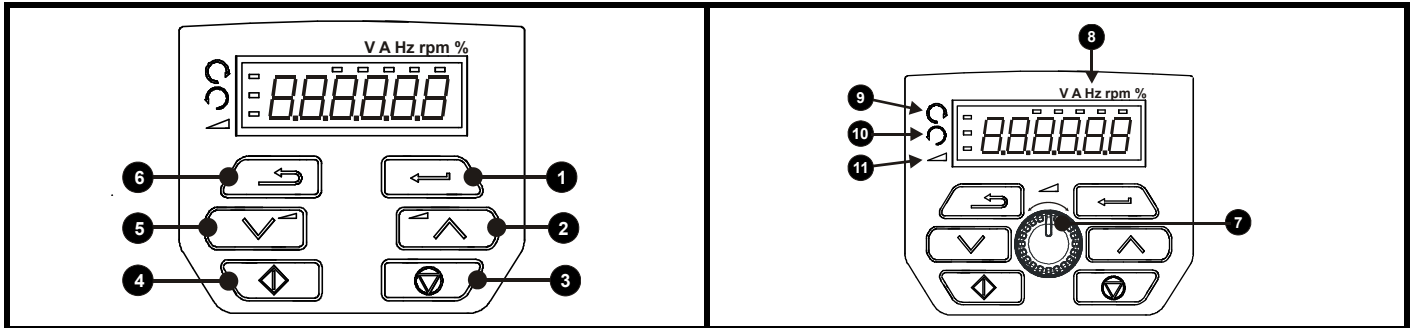

- (1) The *Enter* button is used to enter parameter view or edit mode, or to accept a parameter edit.
- (2 / 5) The *Navigation* button can be used to select individual parameters or to edit parameter values.
- (3) The *Stop / Reset* button is used to stop and reset the drive in keypad mode. It can also be used to reset the drive in terminal mode.
- (4) The *Start* button is used to start the drive in keypad mode.
- (6) The *Escape* button is used to exit from the parameter edit / view mode.
- (7) The *Speed Reference Potentiometer* is used to control the speed reference in keypad mode (only on *Unidrive M101*).

## 2.6 Nameplate description

See Figure 2-2 for location of rating labels.

Figure 2-5 Typical drive rating labels for size 2

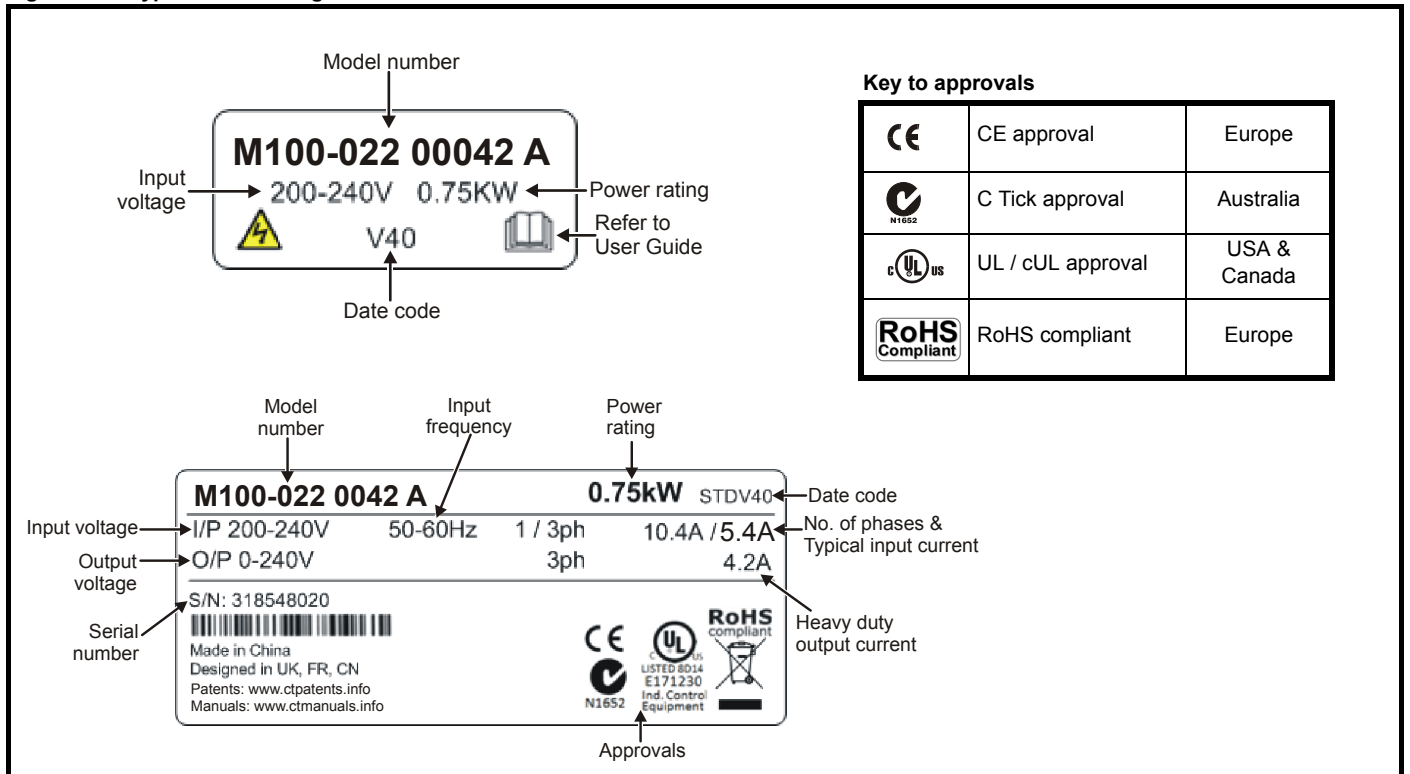

Refer to Figure 2-1 *Model number* on page 9 for further information relating to the labels.

## 2.7 Options

Figure 2-6 Options available with the drive

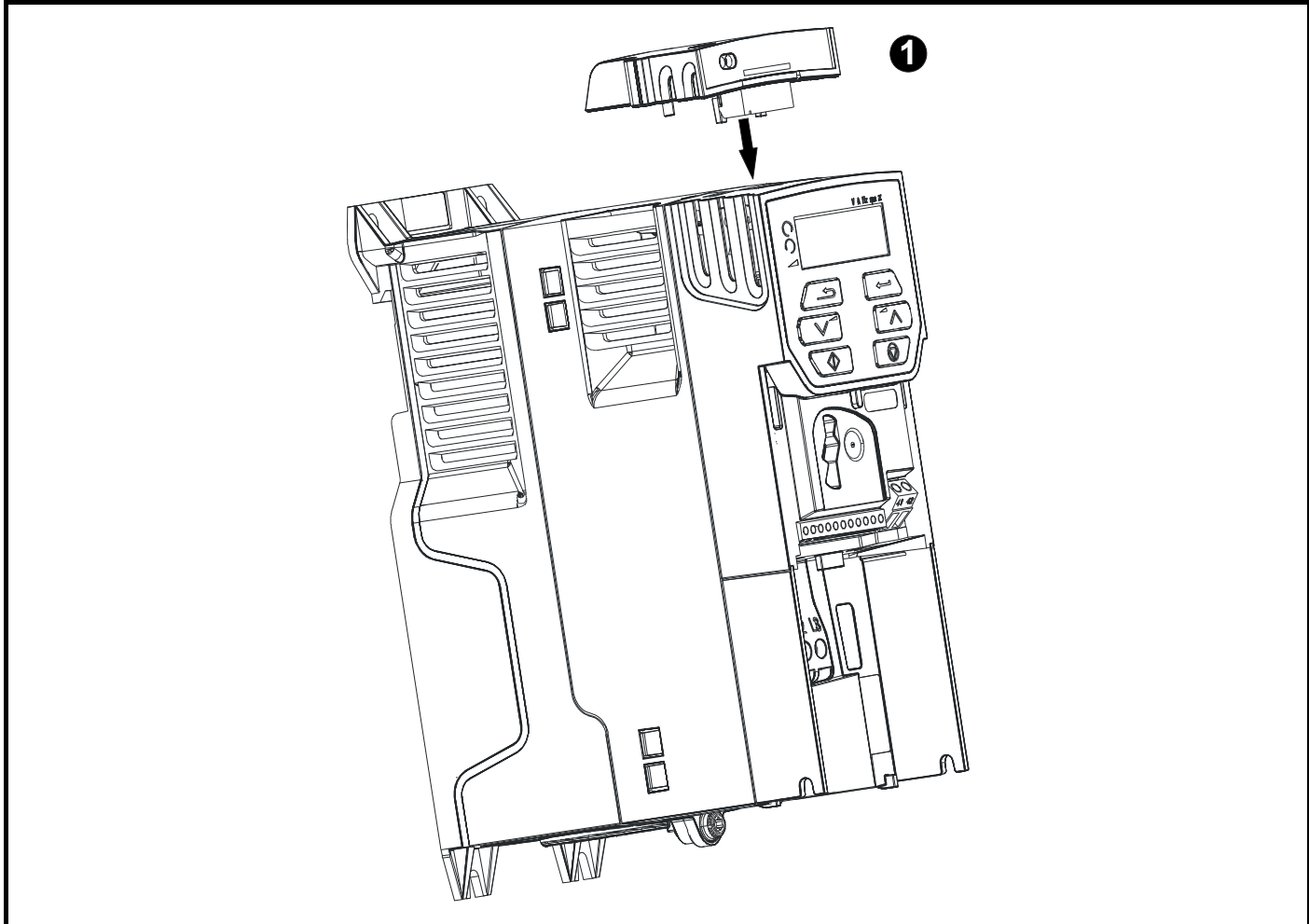

1. AI-Backup Adaptor

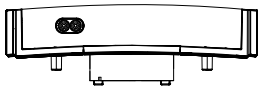
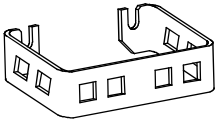

**Table 2-5 Adaptor Interface (AI) option module identification**

Type	Option module	Name	Further Details
Backup		AI-Backup Adaptor	+24 V Backup and SD Card Interface

## 2.8 Items supplied with the drive

The drive is supplied with a copy of the *Quick Start Guide*, a safety information booklet, the Certificate of Quality, plus the items shown in Table 2-6.

**Table 2-6 Parts supplied with the drive**

Description	Size 1	Size 2	Size 3	Size 4
Grounding bracket				
M4 x 8 Double Sem Torx screw	 x2			



## 3 Mechanical installation

This chapter describes how to use all mechanical details to install the drive. The drive is intended to be installed in an enclosure. Key features of this chapter include:

- Enclosure sizing and layout
- Option module installing
- Terminal location and torque settings

### 3.1 Safety information



#### Follow the instructions

The mechanical and electrical installation instructions must be adhered to. Any questions or doubt should be referred to the supplier of the equipment. It is the responsibility of the owner or user to ensure that the installation of the drive and any external option unit, and the way in which they are operated and maintained, comply with the requirements of the Health and Safety at Work Act in the United Kingdom or applicable legislation and regulations and codes of practice in the country in which the equipment is used.



#### Competence of the installer

The drive must be installed by professional assemblers who are familiar with the requirements for safety and EMC. The assembler is responsible for ensuring that the end product or system complies with all the relevant laws in the country where it is to be used.



#### Enclosure

The drive is intended to be mounted in an enclosure which prevents access except by trained and authorized personnel, and which prevents the ingress of contamination. It is designed for use in an environment classified as pollution degree 2 in accordance with IEC 60664-1. This means that only dry, non-conducting contamination is acceptable.

### 3.2 Planning the installation

The following considerations must be made when planning the installation:

#### 3.2.1 Access

Access must be restricted to authorized personnel only. Safety regulations which apply at the place of use must be complied with.

#### 3.2.2 Environmental protection

The drive must be protected from:

- Moisture, including dripping water or spraying water and condensation. An anti-condensation heater may be required, which must be switched off when the drive is running.
- Contamination with electrically conductive material
- Contamination with any form of dust which may restrict the fan, or impair airflow over various components
- Temperature beyond the specified operating and storage ranges
- Corrosive gasses

#### NOTE

During installation it is recommended that the vents on the drive are covered to prevent debris (e.g. wire off-cuts) from entering the drive.

#### 3.2.3 Cooling

The heat produced by the drive must be removed without its specified operating temperature being exceeded. Note that a sealed enclosure gives much reduced cooling compared with a ventilated one, and may need to be larger and/or use internal air circulating fans.

For further information, refer to section 3.6 *Enclosure for standard drives* on page 23.

#### 3.2.4 Electrical safety

The installation must be safe under normal and fault conditions. Electrical installation instructions are given in Chapter 4 *Electrical installation* on page 30.

#### 3.2.5 Fire protection

The drive enclosure is not classified as a fire enclosure. A separate fire enclosure must be provided.

For installation in the USA, a NEMA 12 enclosure is suitable.

For installation outside the USA, the following (based on IEC 62109-1, standard for PV inverters) is recommended.

Enclosure can be metal and/or polymeric, polymer must meet requirements which can be summarized for larger enclosures as using materials meeting at least UL 94 class 5VB at the point of minimum thickness.

Air filter assemblies to be at least class V-2.

The location and size of the bottom shall cover the area shown in Figure 3-1. Any part of the side which is within the area traced out by the 5° angle is also considered to be part of the bottom of the fire enclosure.

Figure 3-1 Fire enclosure bottom layout

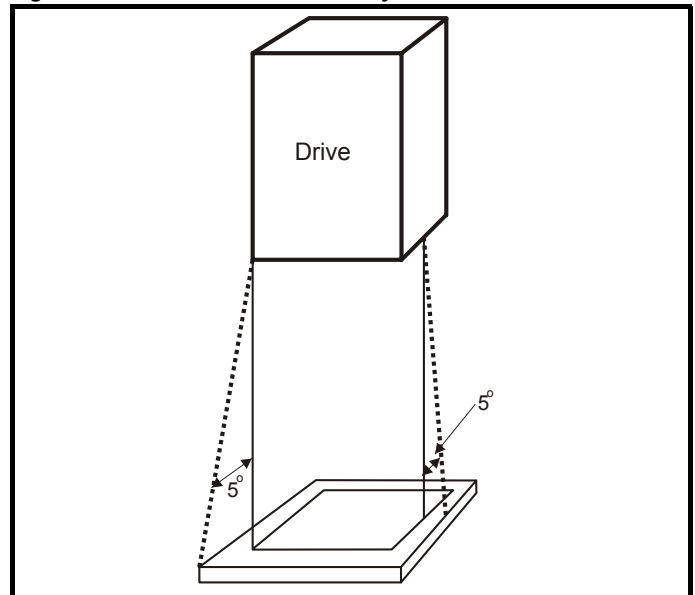

The bottom, including the part of the side considered to be part of the bottom, must be designed to prevent escape of burning material - either by having no openings or by having a baffle construction. This means that openings for cables etc. must be sealed with materials meeting the 5VB requirement, or else have a baffle above. See Figure 3-2 for acceptable baffle construction. This does not apply for mounting in an enclosed electrical operating area (restricted access) with concrete floor.

Figure 3-2 Fire enclosure baffle construction

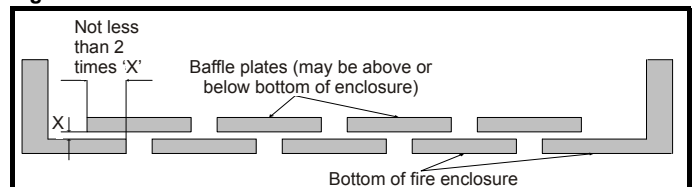

### 3.2.6 Electromagnetic compatibility

Variable speed drives are powerful electronic circuits which can cause electromagnetic interference if not installed correctly with careful attention to the layout of the wiring.

Some simple routine precautions can prevent disturbance to typical industrial control equipment.

If it is necessary to meet strict emission limits, or if it is known that electromagnetically sensitive equipment is located nearby, then full precautions must be observed. In-built into the drive, is an internal EMC filter, which reduces emissions under certain conditions. If these conditions are exceeded, then the use of an external EMC filter may be required at the drive inputs, which must be located very close to the drives. Space must be made available for the filters and allowance made for carefully segregated wiring. Both levels of precautions are covered in section 4.7 *EMC (Electromagnetic compatibility)* on page 41.

### 3.2.7 Hazardous areas

The drive must not be located in a classified hazardous area unless it is installed in an approved enclosure and the installation is certified.

## 3.3 Terminal cover removal



#### Isolation device

The AC and / or DC power supply must be disconnected from the drive using an approved isolation device before any cover is removed from the drive or before any servicing work is performed.



#### Stored charge

The drive contains capacitors that remain charged to a potentially lethal voltage after the AC and / or DC power supply has been disconnected. If the drive has been energized, the power supply must be isolated at least ten minutes before work may continue.

Normally, the capacitors are discharged by an internal resistor. Under certain, unusual fault conditions, it is possible that the capacitors may fail to discharge, or be prevented from being discharged by a voltage applied to the output terminals. If the drive has failed in a manner that causes the display to go blank immediately, it is possible the capacitors will not be discharged. In this case, consult Control Techniques or their authorized distributor.

### 3.3.1 Removing the terminal covers

Figure 3-3 Location and identification of terminal covers

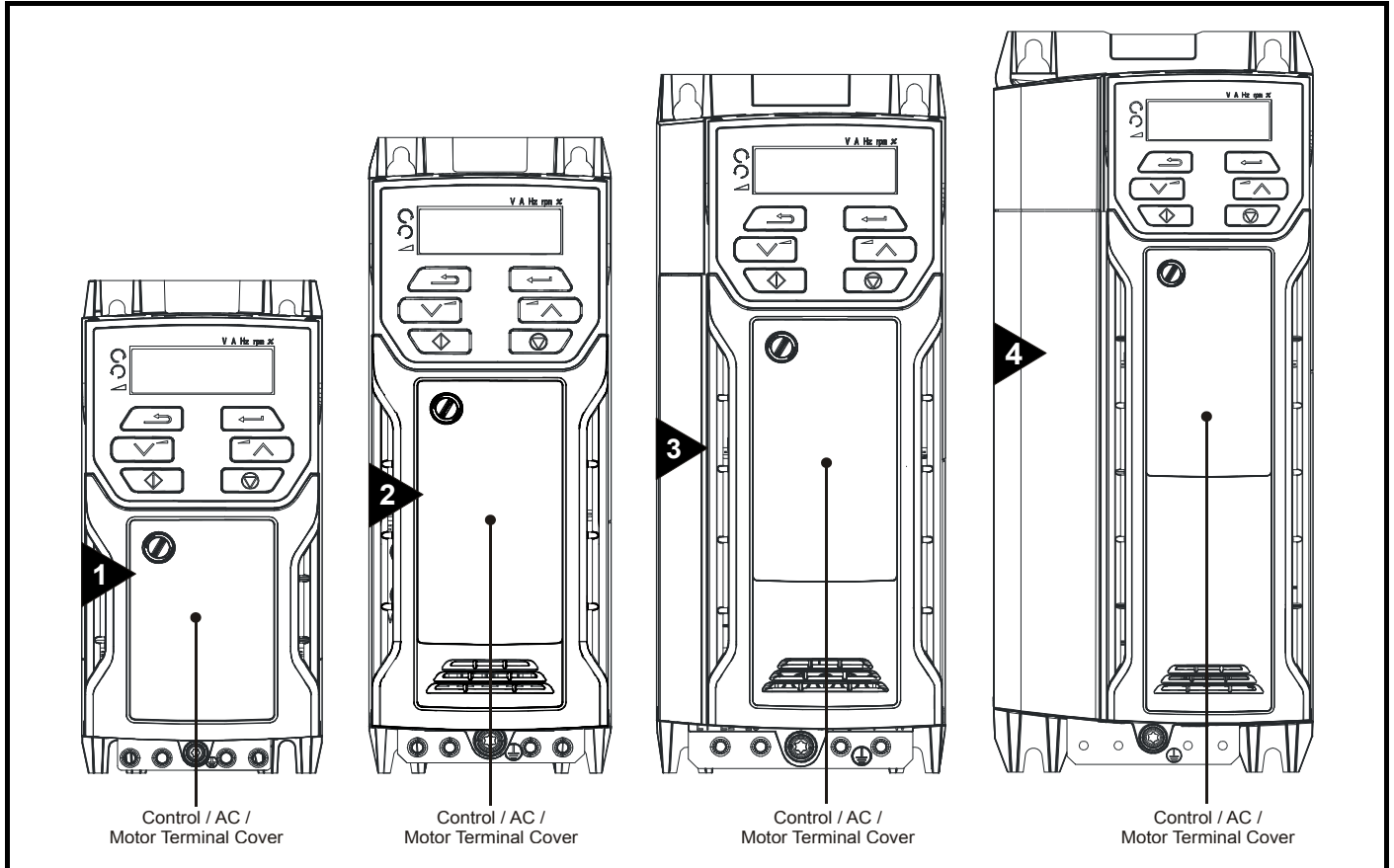

#### NOTE

The drives shown above have a single removable terminal cover which provides access to all electrical connections, i.e. Control, AC, Motor and Brake functions. Figure 3-4 on page 19 illustrates the three steps required to remove the drive terminal covers.

**Figure 3-4 Removing the terminal cover**

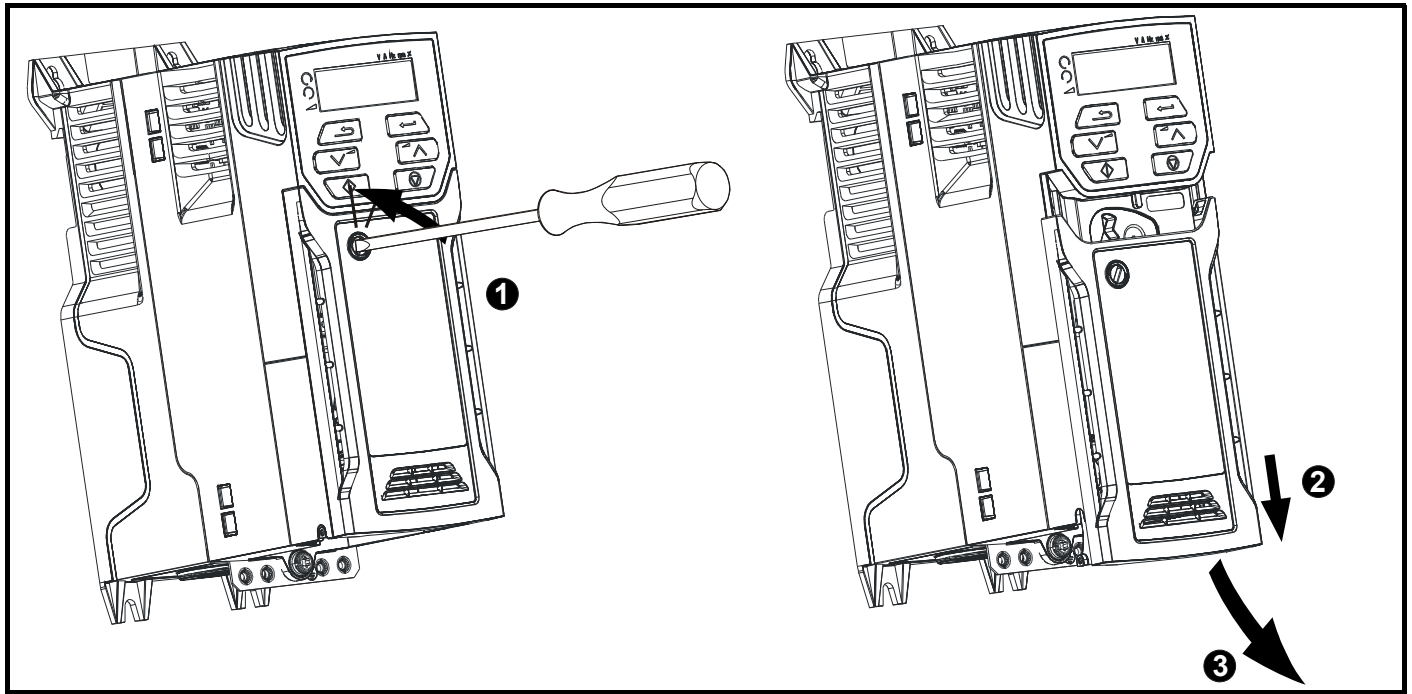

1. Using a flat bladed screwdriver, turn the terminal cover locking clip anti-clockwise by approximately 30°
2. Slide the terminal cover down
3. Remove terminal cover

### 3.4 Installing / removing option

**Figure 3-5 Installing the AI-Backup adaptor**

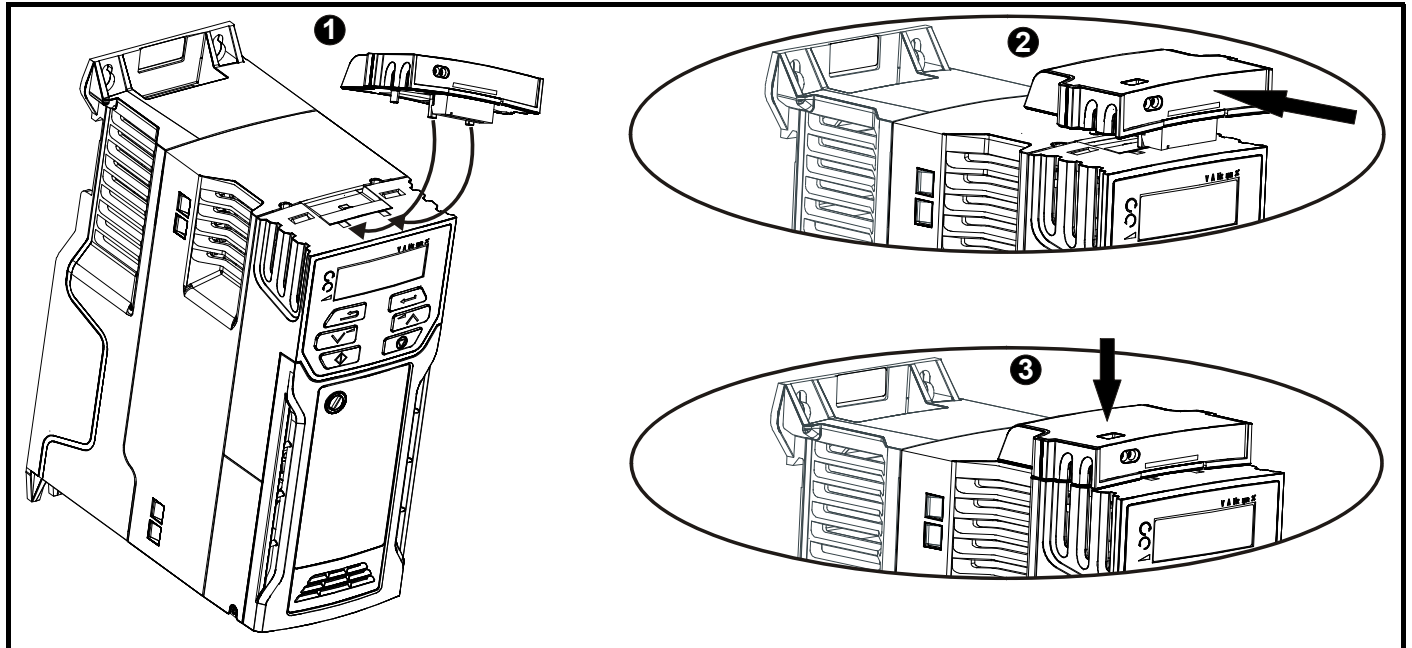

1. Identify the two plastic fingers on the underside of the AI-Backup adaptor (1) - then insert the two fingers into the corresponding slots in the spring-loaded sliding cover on the top of the drive.
2. Hold the adaptor firmly and push the spring loaded protective cover towards the back of the drive to expose the connector block (2) below.
3. Press the adaptor downwards (3) until the adaptor connector locates into the drive connection below.

**Figure 3-6 Removal of the AI-Backup Adaptor**

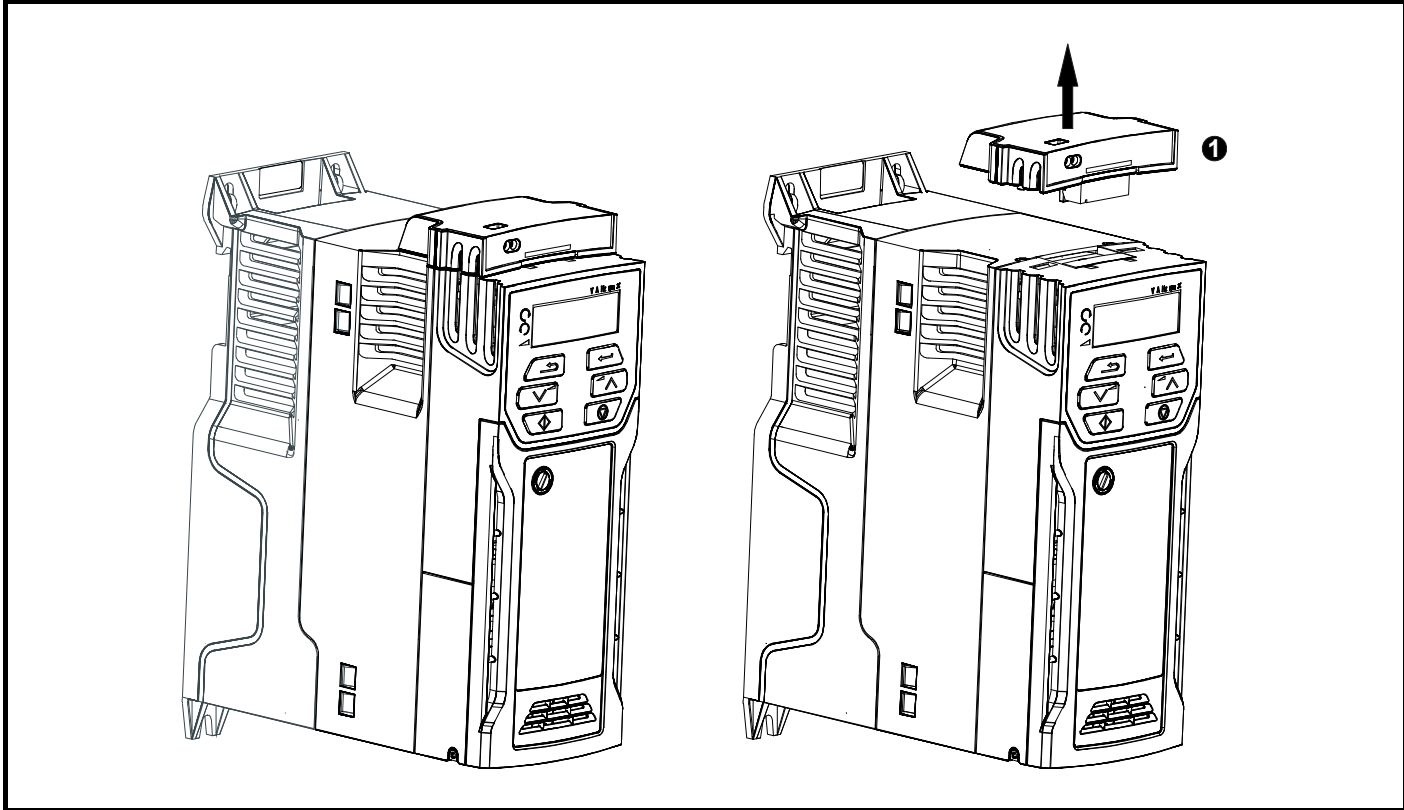

• To remove the AI-Backup adaptor, pull it up away from the drive in the direction shown (1)

### 3.5 Dimensions and mounting methods

The drive is surface mounted. The following drawings show the dimensions of the drive and mounting holes to allow a back plate to be prepared.

#### 3.5.1 Surface mounting

**Figure 3-7 Surface mounting the size 1 drive**

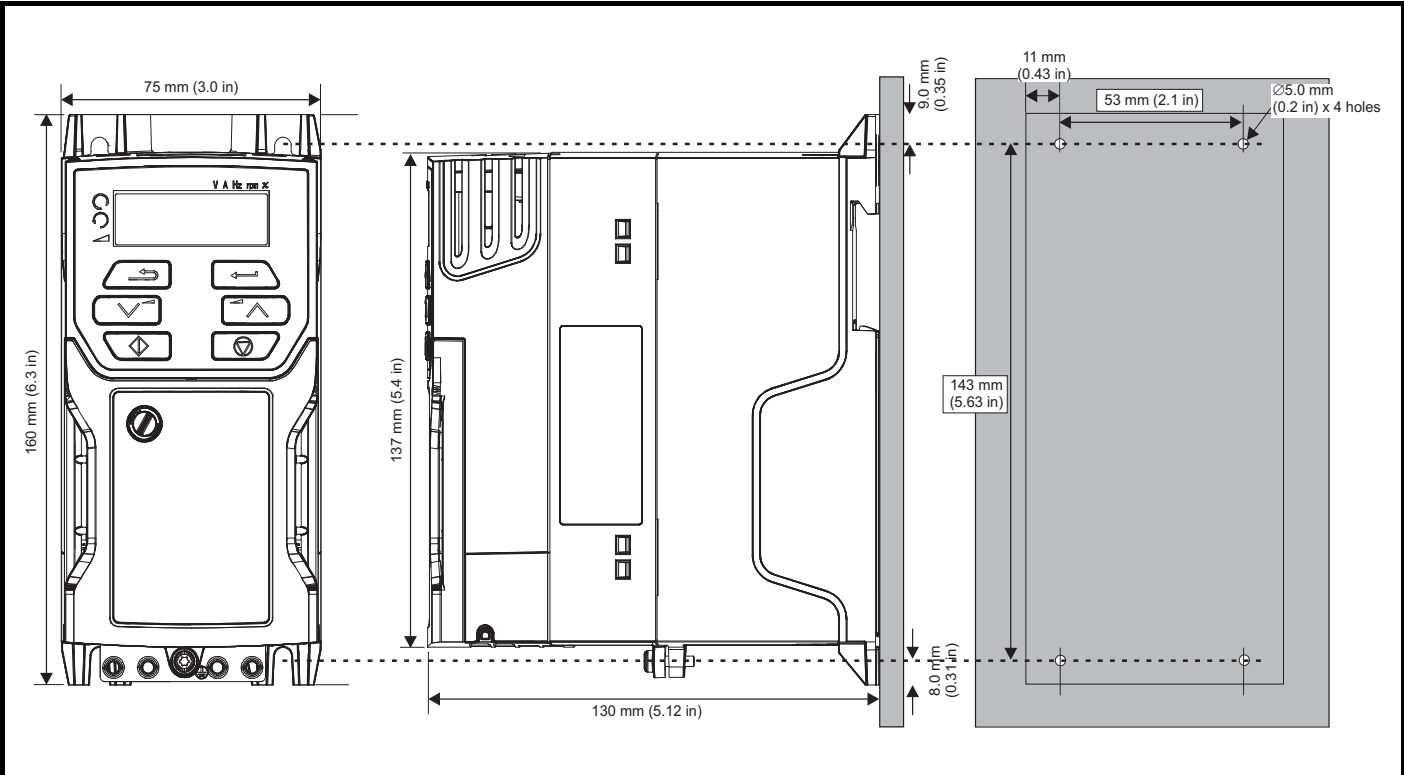

**Figure 3-8 Surface mounting the size 2 drive**

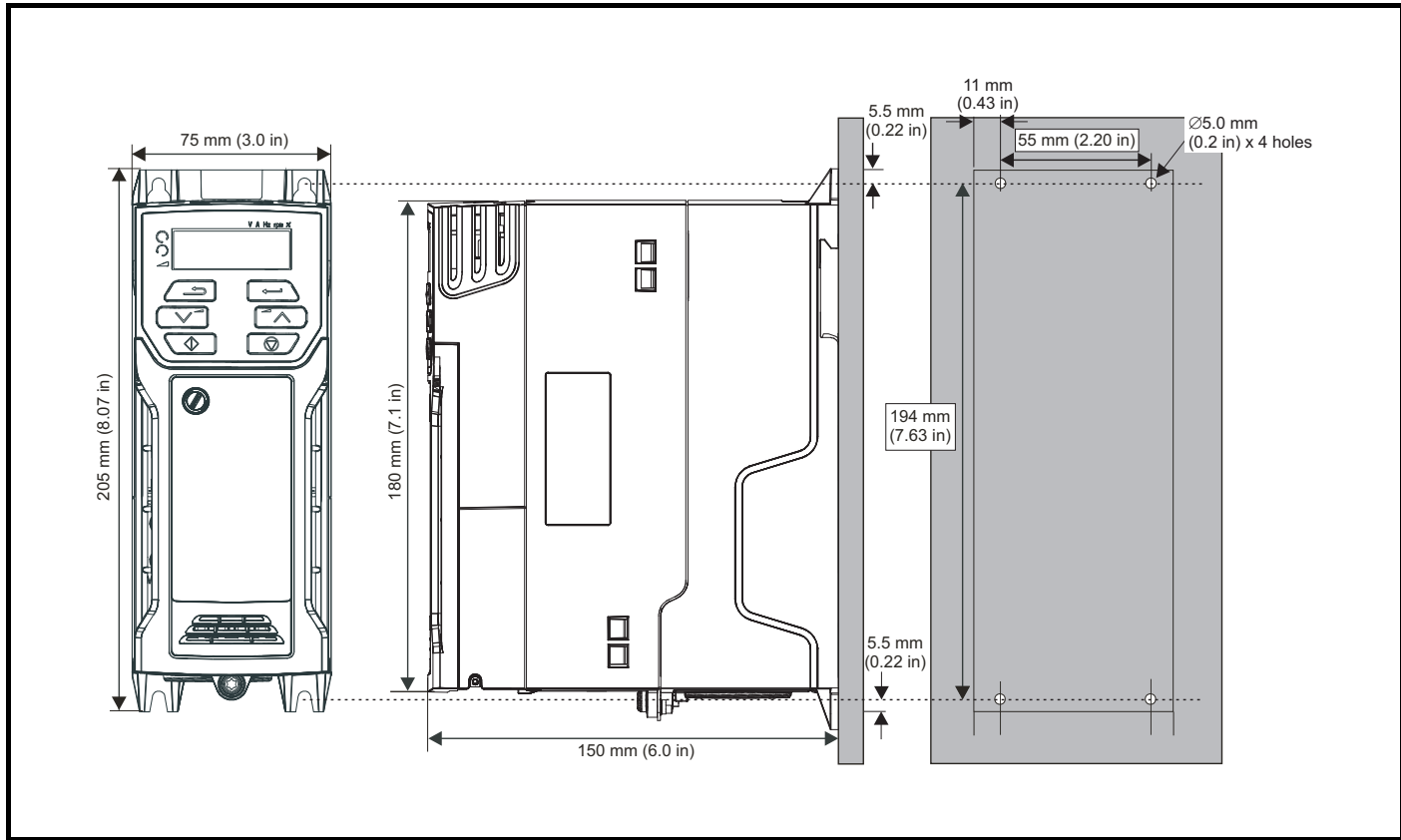

**Figure 3-9 Surface mounting the size 3 drive**

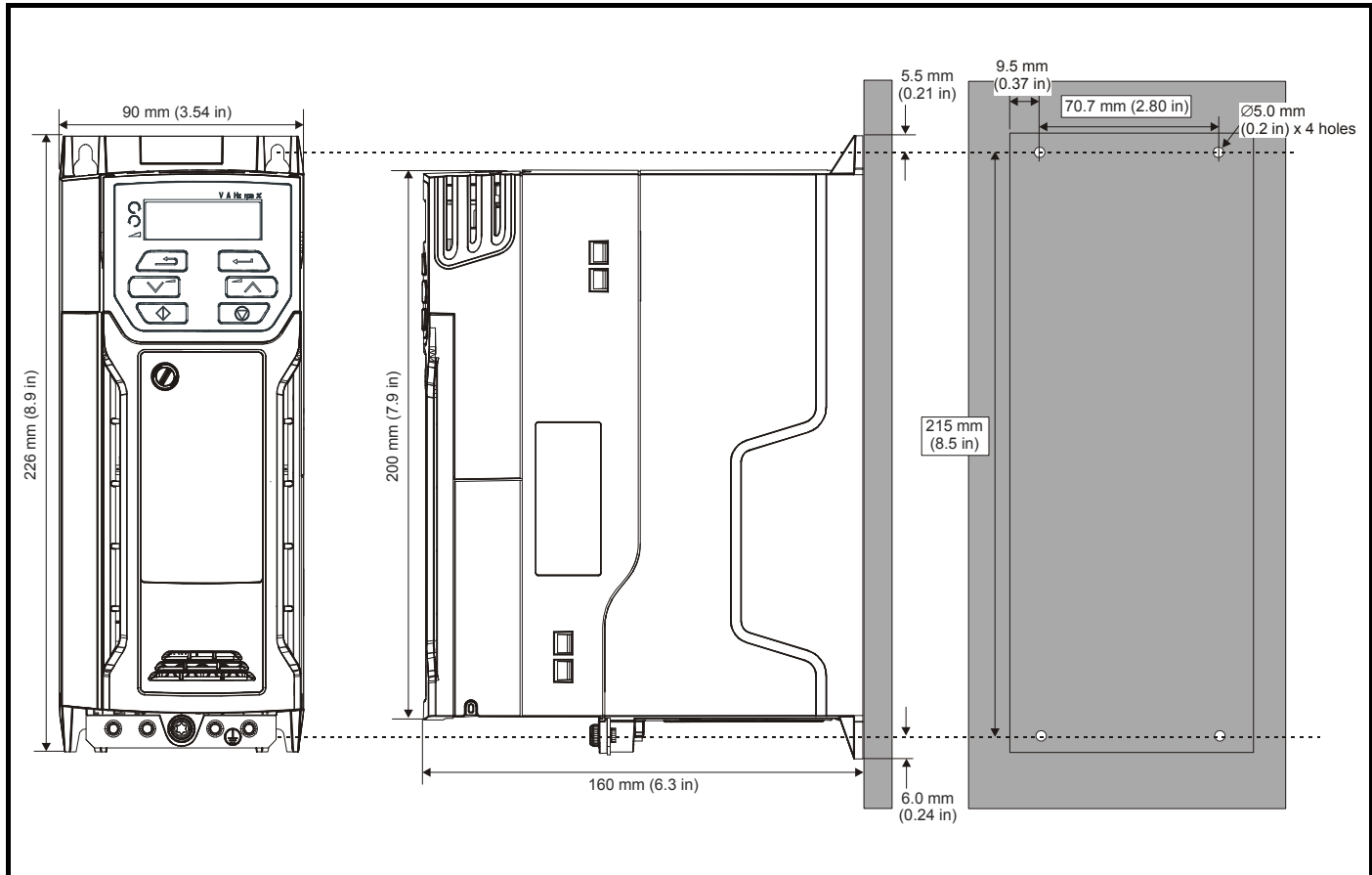

**Figure 3-10 Surface mounting the size 4 drive**

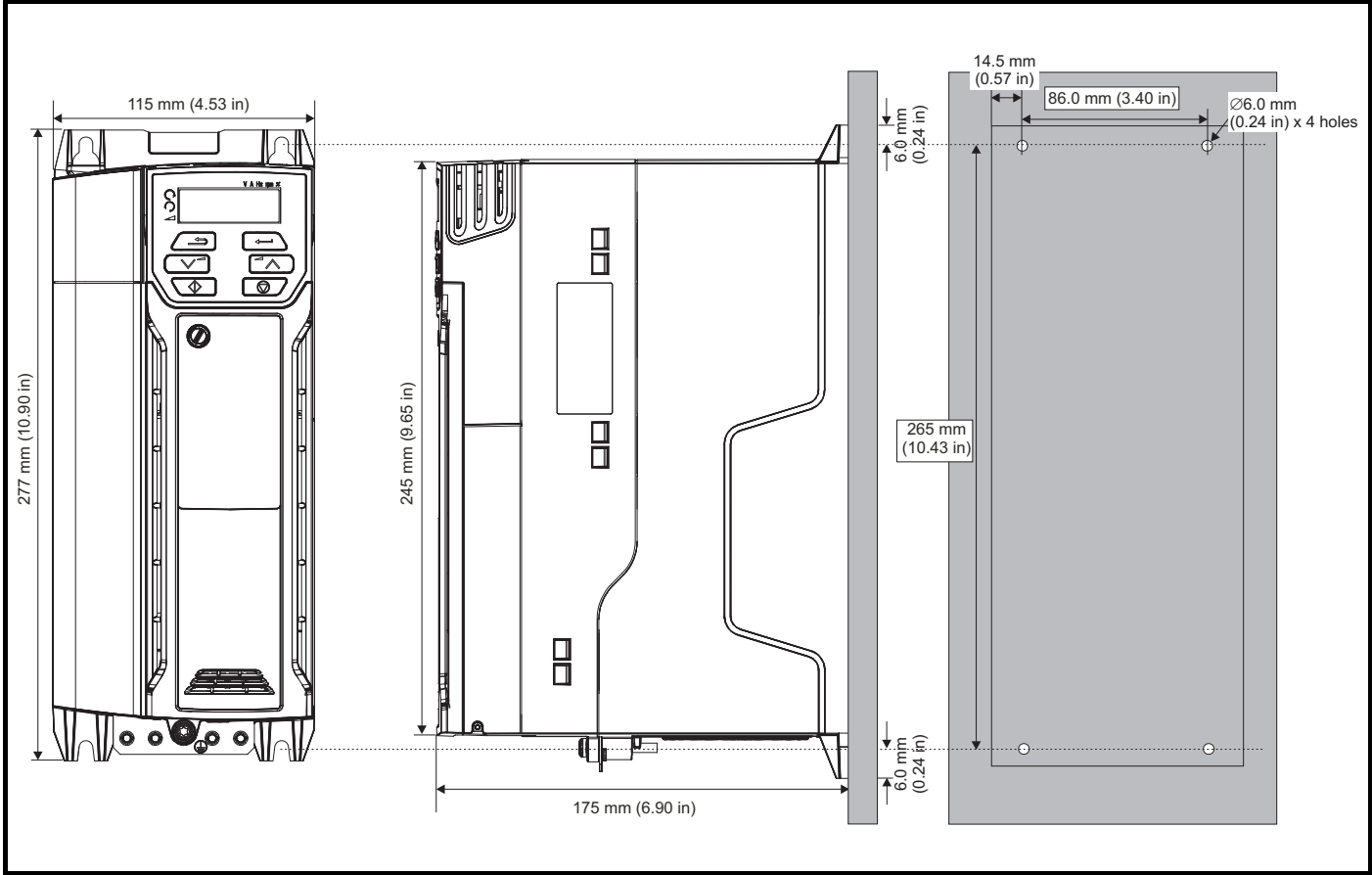

**Figure 3-11 Size 2 M101 Variant with front panel potentiometer control**

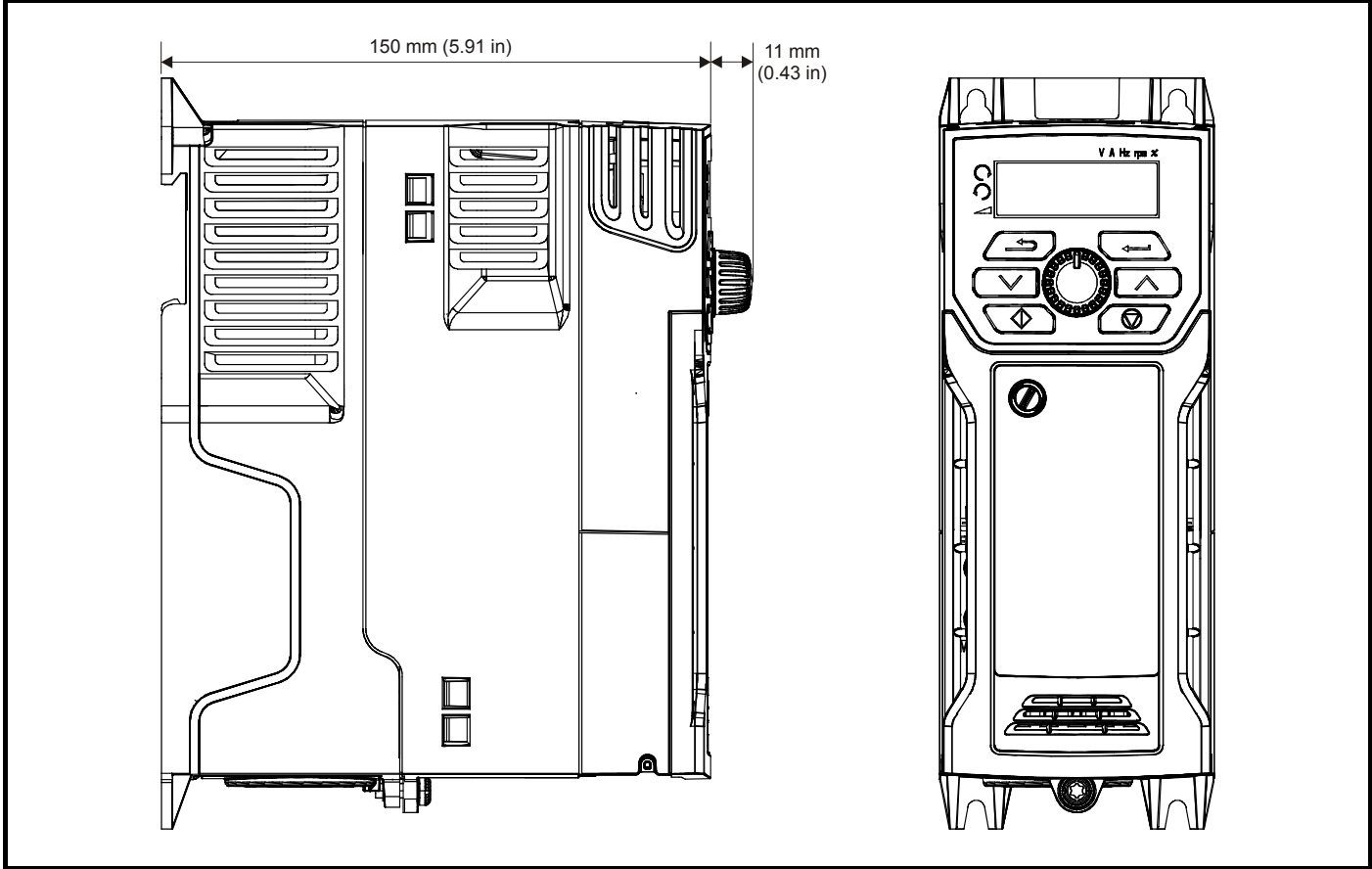

### 3.6 Enclosure for standard drives

#### 3.6.1 Enclosure layout

Please observe the clearances in the diagram below taking into account any appropriate notes for other devices / auxiliary equipment when planning the installation.

Figure 3-12 Enclosure layout

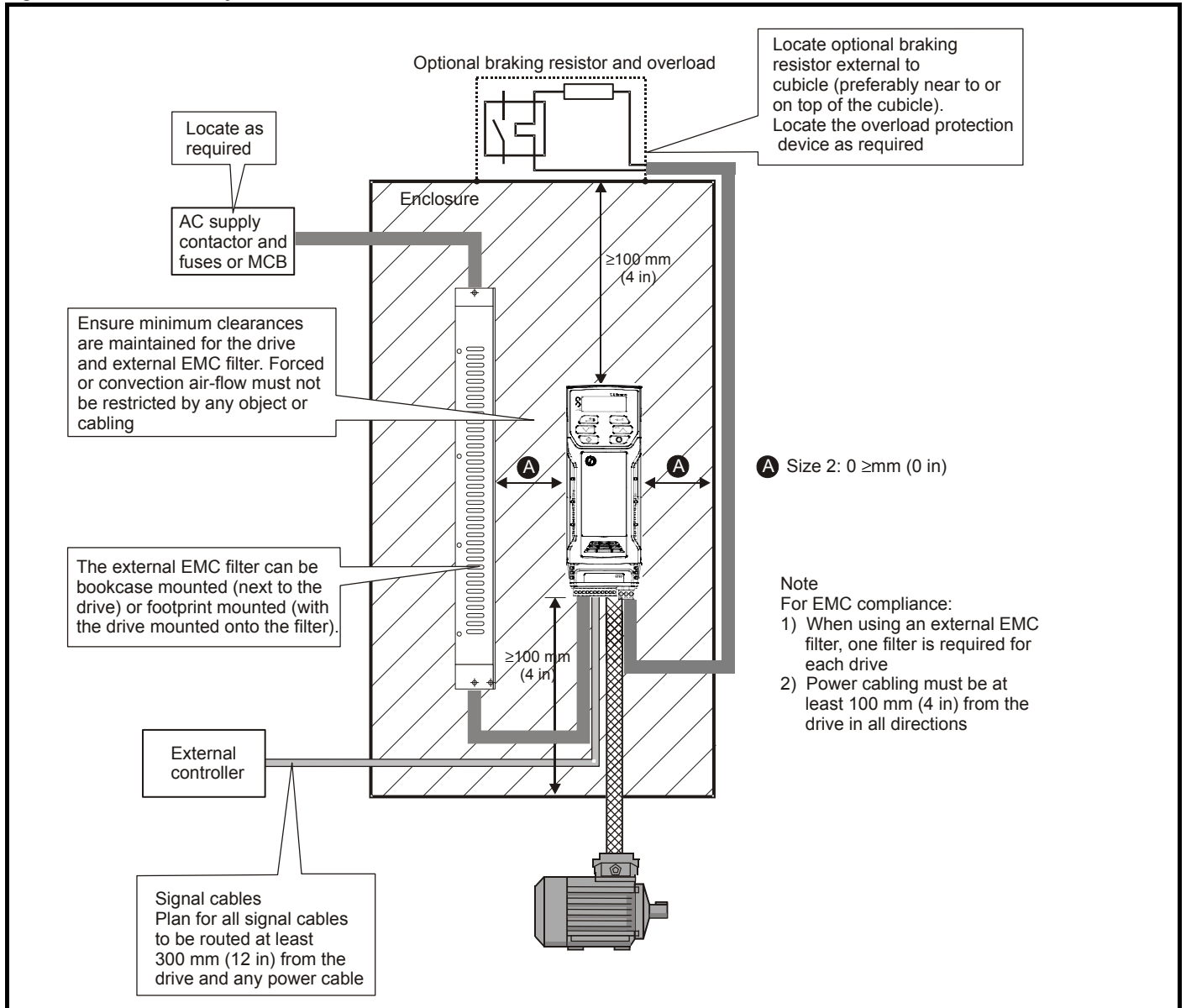

### 3.6.2 Enclosure sizing

1. Add the dissipation figures from section 11.1.2 *Power dissipation* on page 105 for each drive that is to be installed in the enclosure.
2. If an external EMC filter is to be used with each drive, add the dissipation figures from section 11.2.1 *EMC filter ratings* on page 115 for each external EMC filter that is to be installed in the enclosure.
3. If the braking resistor is to be mounted inside the enclosure, add the average power figures from for each braking resistor that is to be installed in the enclosure.
4. Calculate the total heat dissipation (in Watts) of any other equipment to be installed in the enclosure.
5. Add the heat dissipation figures obtained above. This gives a figure in Watts for the total heat that will be dissipated inside the enclosure.

#### Calculating the size of a sealed enclosure

The enclosure transfers internally generated heat into the surrounding air by natural convection (or external forced air flow); the greater the surface area of the enclosure walls, the better is the dissipation capability. Only the surfaces of the enclosure that are unobstructed (not in contact with a wall or floor) can dissipate heat.

Calculate the minimum required unobstructed surface area  $A_e$  for the enclosure from:

$$A_e = \frac{P}{k(T_{int} - T_{ext})}$$

Where:

$A_e$	Unobstructed surface area in $m^2$ ( $1 m^2 = 10.9 ft^2$ )
$T_{ext}$	Maximum expected temperature in $^{\circ}C$ <i>outside</i> the enclosure
$T_{int}$	Maximum permissible temperature in $^{\circ}C$ <i>inside</i> the enclosure
$P$	Power in Watts dissipated by <i>all</i> heat sources in the enclosure
$k$	Heat transmission coefficient of the enclosure material in $W/m^2/^{\circ}C$

#### Example

To calculate the size of an enclosure for the following:

- Two drives operating at the Normal Duty rating
- External EMC filter for each drive
- Braking resistors are to be mounted outside the enclosure
- Maximum ambient temperature inside the enclosure:  $40^{\circ}C$
- Maximum ambient temperature outside the enclosure:  $30^{\circ}C$

For example, if the power dissipation from each drive is 187 W and the power dissipation from each external EMC filter is 9.2 W.

Total dissipation:  $2 \times (187 + 9.2) = 392.4 W$

#### NOTE

Power dissipation for the drives and the external EMC filters can be obtained from Chapter 11 *Technical data* on page 103.

The enclosure is to be made from painted 2 mm (0.079 in) sheet steel having a heat transmission coefficient of  $5.5 W/m^2/^{\circ}C$ . Only the top, front, and two sides of the enclosure are free to dissipate heat.

The value of  $5.5 W/m^2/^{\circ}C$  can generally be used with a sheet steel enclosure (exact values can be obtained by the supplier of the material). If in any doubt, allow for a greater margin in the temperature rise.

Figure 3-13 Enclosure having front, sides and top panels free to dissipate heat

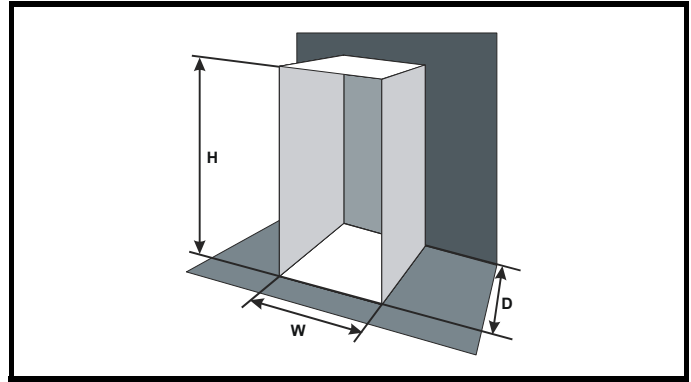

Insert the following values:

$T_{int}$	$40^{\circ}C$
$T_{ext}$	$30^{\circ}C$
$k$	5.5
$P$	392.4 W

The minimum required heat conducting area is then:

$$A_e = \frac{392.4}{5.5(40 - 30)}$$

$$= 7.135 m^2 (77.8 ft^2) \quad (1 m^2 = 10.9 ft^2)$$

Estimate two of the enclosure dimensions - the height (H) and depth (D), for instance. Calculate the width (W) from:

$$W = \frac{A_e - 2HD}{H + D}$$

Inserting  $H = 2m$  and  $D = 0.6m$ , obtain the minimum width:

$$W = \frac{7.135 - (2 \times 2 \times 0.6)}{2 + 0.6}$$

$$= 1.821 m (71.7 in)$$

If the enclosure is too large for the space available, it can be made smaller only by attending to one or all of the following:

- Using a lower PWM switching frequency to reduce the dissipation in the drives
- Reducing the ambient temperature outside the enclosure, and/or applying forced-air cooling to the outside of the enclosure
- Reducing the number of drives in the enclosure
- Removing other heat-generating equipment

#### Calculating the air-flow in a ventilated enclosure

The dimensions of the enclosure are required only for accommodating the equipment. The equipment is cooled by the forced air flow.

Calculate the minimum required volume of ventilating air from:

$$V = \frac{3kP}{T_{int} - T_{ext}}$$

Where:

$V$	Air-flow in $m^3$ per hour ( $1 m^3/hr = 0.59 ft^3/min$ )
$T_{ext}$	Maximum expected temperature in $^{\circ}C$ <i>outside</i> the enclosure
$T_{int}$	Maximum permissible temperature in $^{\circ}C$ <i>inside</i> the enclosure
$P$	Power in Watts dissipated by <i>all</i> heat sources in the enclosure
$k$	Ratio of $\frac{P_o}{P_i}$

Where:

$P_o$  is the air pressure at sea level

$P_i$  is the air pressure at the installation

Typically use a factor of 1.2 to 1.3, to allow also for pressure-drops in dirty air-filters.



### Example

To calculate the size of an enclosure for the following:

- Three drives operating at the Normal Duty rating
- External EMC filter for each drive
- Braking resistors are to be mounted outside the enclosure
- Maximum ambient temperature inside the enclosure: 40 °C
- Maximum ambient temperature outside the enclosure: 30 °C

For example, dissipation of each drive: 101 W and dissipation of each external EMC filter: 6.9 W (max).

Total dissipation:  $3 \times (101 + 6.9) = 323.7 \text{ W}$

Insert the following values:

$T_{\text{int}}$  40 °C  
 $T_{\text{ext}}$  30 °C  
 $k$  1.3  
 $P$  323.7 W

Then:

$$V = \frac{3 \times 1.3 \times 323.7}{40 - 30}$$

$$= 126.2 \text{ m}^3/\text{hr} \text{ (74.5 ft}^3/\text{min)} \text{ (1 m}^3/\text{hr} = 0.59 \text{ ft}^3/\text{min)}$$

## 3.7 Enclosure design and drive ambient temperature

Drive derating is required for operation in high ambient temperatures

Totally enclosing or through panel mounting the drive in either a sealed cabinet (no airflow) or in a well ventilated cabinet makes a significant difference on drive cooling.

The chosen method affects the ambient temperature value ( $T_{\text{rate}}$ ) which should be used for any necessary derating to ensure sufficient cooling for the whole of the drive.

The ambient temperature for the four different combinations is defined below:

1. Totally enclosed with no air flow (<2 m/s) over the drive  
 $T_{\text{rate}} = T_{\text{int}} + 5 \text{ °C}$
2. Totally enclosed with air flow (>2 m/s) over the drive  
 $T_{\text{rate}} = T_{\text{int}}$
3. Through panel mounted with no airflow (<2 m/s) over the drive  
 $T_{\text{rate}} = \text{the greater of } T_{\text{ext}} + 5 \text{ °C, or } T_{\text{int}}$
4. Through panel mounted with air flow (>2 m/s) over the drive  
 $T_{\text{rate}} = \text{the greater of } T_{\text{ext}} \text{ or } T_{\text{int}}$

Where:

$T_{\text{ext}}$  = Temperature outside the cabinet  
 $T_{\text{int}}$  = Temperature inside the cabinet  
 $T_{\text{rate}}$  = Temperature used to select current rating from tables in Chapter 11 *Technical data* on page 103.

## 3.8 Heatsink fan operation

The drive is ventilated by an internal heatsink fan. The fan channels air through the heatsink chamber.

Ensure the minimum clearances around the drive are maintained to allow air to flow freely.

The heatsink fan on size 1, 2, 3, and 4 frames is a variable speed fan.

The drive controls the speed at which the fan runs based on the temperature of the heatsink and the drive's thermal model system. The maximum speed at which the fan operates can be limited in Pr **06.045**.

This could incur an output current derating.

### 3.9 External EMC filter

The external EMC filter details for each drive rating are provided in the table below.

**Table 3-1 Drive and EMC filter cross reference**

Frame size	Voltage V	Phases 1 or 3	Part number	Type	Weight	
					Kg	lb
1	All	1	4200-1000	Standard		
	All	1	4200-1001	Low leakage		
2	100	1	4200-2000	Standard		
		1	4200-2001	Standard		
	200	1	4200-2002	Low leakage		
		3	4200-2003	Standard		
		3	4200-2004	Low leakage		
		3	4200-2005	Standard		
400	3	4200-2006	Low leakage			
3	200	1	4200-3000	Standard		
		1	4200-3001	Low leakage		
		3	4200-3004	Standard		
		3	4200-3005	Low leakage		
	400	3	4200-3008	Standard		
		3	4200-3009	Low leakage		
4	200	1	4200-4000	Standard		
		1	4200-4001	Low leakage		
		3	4200-4002	Standard		
		3	4200-4003	Low leakage		
	400	3	4200-4004	Standard		
		3	4200-4005	Low leakage		

Mount the external EMC filter following the guidelines in section 4.7.5 *Compliance with generic emission standards* on page 44.

**Figure 3-14 Footprint mounting the EMC filter**

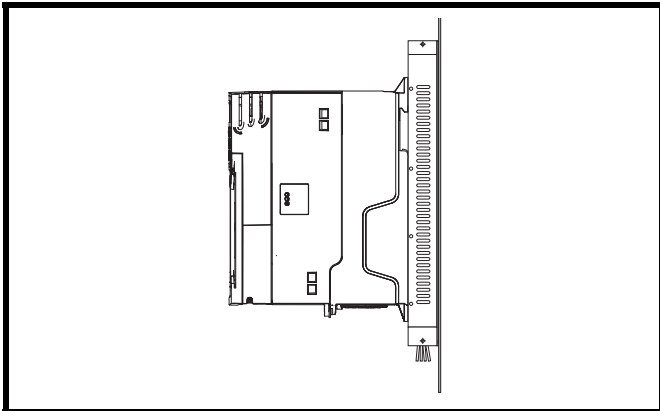

**Figure 3-15 Bookcase mounting the EMC filter**

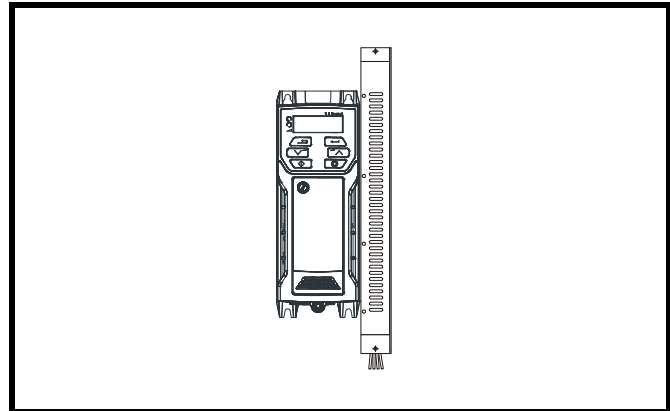

**Figure 3-16 Size 1 to 4 external EMC filter**

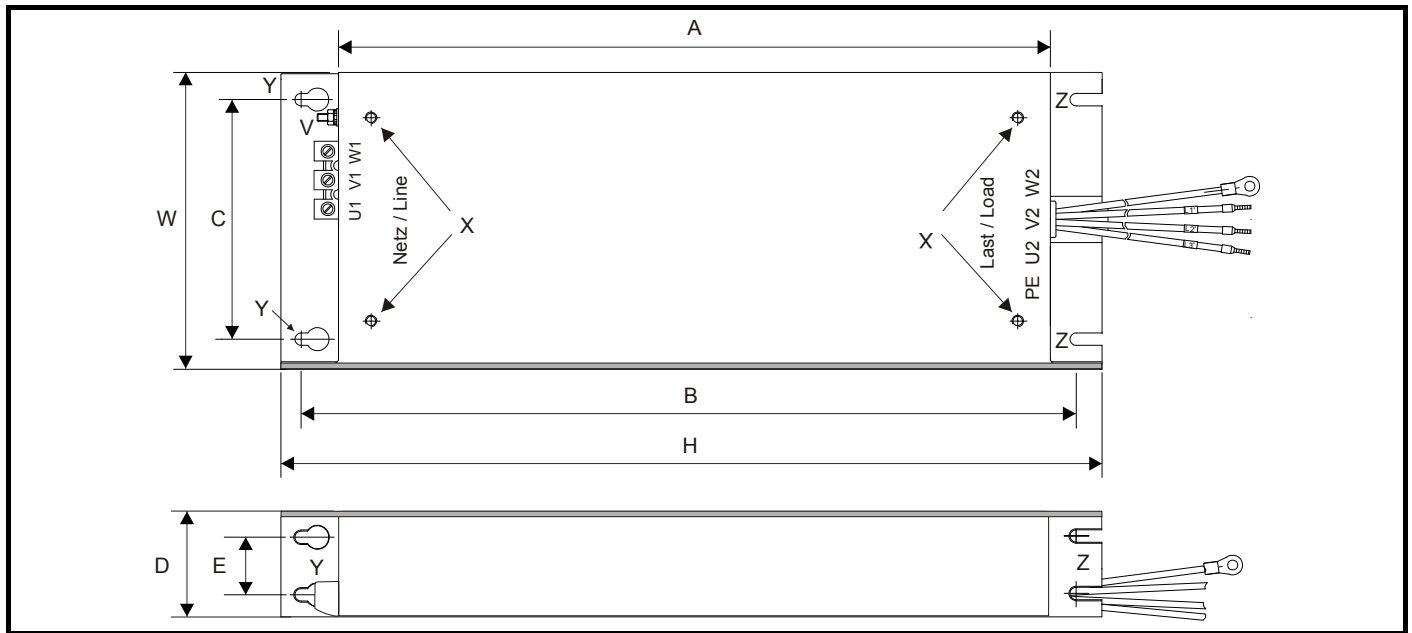

V: Ground stud  
 Z: Bookcase mounting slot diameter.  
 X: Threaded holes for footprint mounting of the drive  
 CS: Cable size  
 Y: Footprint mounting hole diameter

**Table 3-2 Size 1 external EMC filter dimensions**

CT part number	A	B	C	D	E	H	W	V	X	Y	Z	CS

**Table 3-3 Size 2 external EMC filter dimensions**

CT part number	A	B	C	D	E	H	W	V	X	Y	Z	CS

**Table 3-4 Size 3 external EMC filter dimensions**

CT part number	A	B	C	D	E	H	W	V	X	Y	Z	CS

**Table 3-5 Size 4 external EMC filter dimensions**

CT part number	A	B	C	D	E	H	W	V	X	Y	Z	CS

### 3.10 Electrical terminals

#### 3.10.1 Location of the power and ground terminals

Figure 3-17 Locations of the power and ground terminals

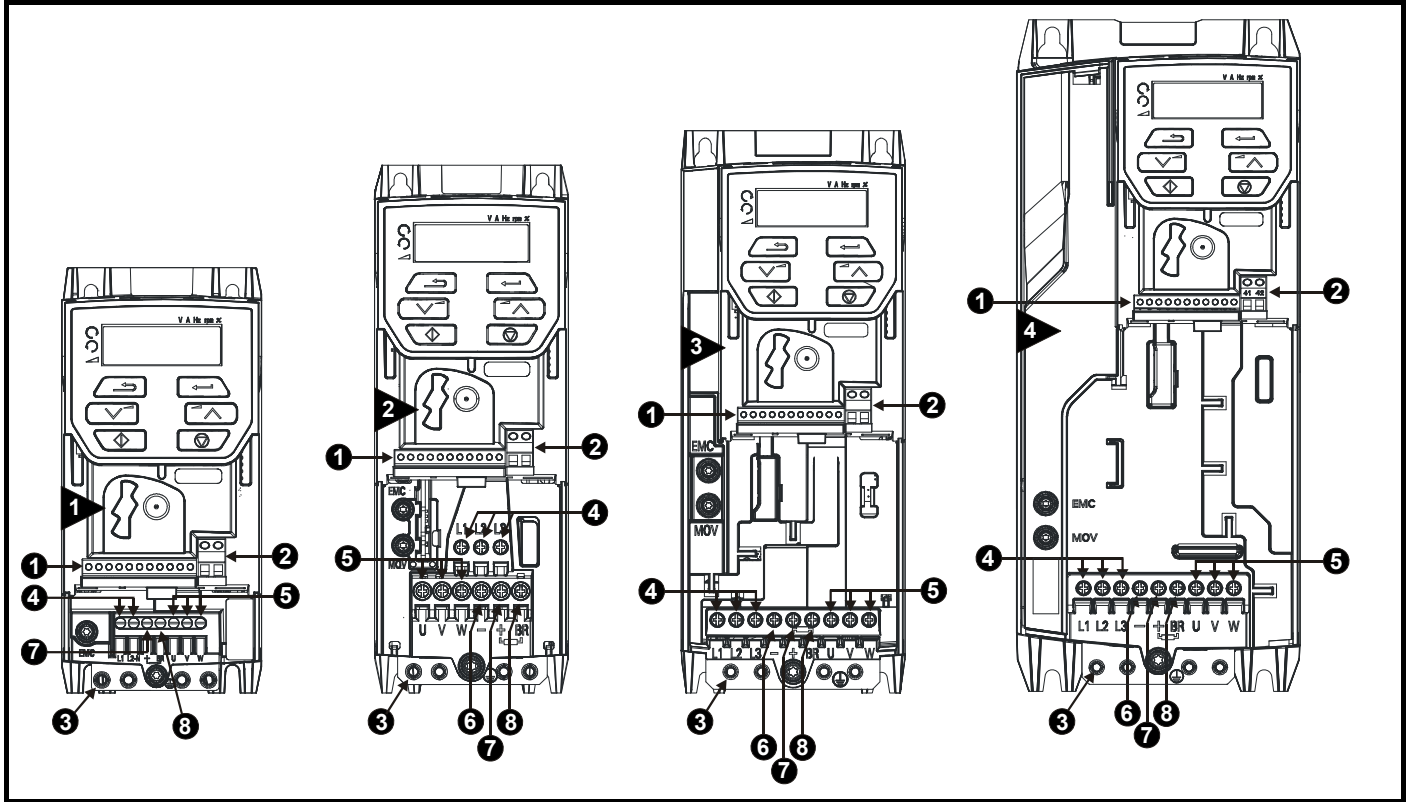

**Key:**

- |                       |                       |                   |
|-----------------------|-----------------------|-------------------|
| 1. Control terminals  | 4. AC power terminals | 7. DC bus +       |
| 2. Relay terminals    | 5. Motor terminals    | 8. Brake terminal |
| 3. Ground connections | 6. DC bus -           |                   |

#### 3.10.2 Terminal sizes and torque settings

**WARNING** To avoid a fire hazard and maintain validity of the UL listing, adhere to the specified tightening torques for the power and ground terminals. Refer to the following tables.

Table 3-6 Drive relay terminal data

Model	Connection type	Torque setting
All	Screw terminals	0.5 N m (0.4 lb ft)

Table 3-7 Drive power terminal data

Model size	AC terminals	DC and braking	Ground terminal
1	0.5 N m (0.4 lb ft)		1.5 N m (1.0 lb ft)
2	1.4 N m (1.0 lb ft)		
3			
4			

Table 3-8 Terminal block maximum cable sizes

Model size	Terminal block description	Max cable size
All	Control connector	1.5 mm <sup>2</sup> (16 AWG)
	2 way relay connector	2.5 mm <sup>2</sup> (12 AWG)
All	AC input power connector	6 mm <sup>2</sup> (10 AWG)
All	AC output power connector	2.5 mm <sup>2</sup> (12 AWG)

Table 3-9 External EMC filter terminal data

CT part number	Power connections		Ground connections	
	Max cable size	Max torque	Ground stud size	Max torque

### 3.11 Routine maintenance

The drive should be installed in a cool, clean, well ventilated location. Contact with moisture and/or dust with the drive should be avoided.

Regular checks of the following should be carried out to ensure drive / installation reliability are maximized:

<b>Environment</b>	
Ambient temperature	Ensure the enclosure temperature remains at or below maximum specified
Dust	Ensure the drive remains dust free – check that the heatsink and drive fan are not gathering dust. The lifetime of the fan is reduced in dusty environments
Moisture	Ensure the drive enclosure shows no signs of condensation
<b>Enclosure</b>	
Enclosure door filters	Ensure filters are not blocked and that air is free to flow
<b>Electrical</b>	
Screw connections	Ensure all screw terminals remain tight
Crimp terminals	Ensure all crimp terminals remains tight – check for any discoloration which could indicate overheating
Cables	Check all cables for signs of damage

## 4 Electrical installation

Many cable management features have been incorporated into the product and accessories, this chapter shows how to optimize them. Key features include:

- Internal EMC filter
- EMC compliance with shielding / grounding accessories
- Product rating, fusing and cabling information
- Brake resistor details (selection / ratings)

**Electric shock risk**  
 The voltages present in the following locations can cause severe electric shock and may be lethal:

- AC supply cables and connections
- DC and brake cables, and connections
- Output cables and connections
- Many internal parts of the drive, and external option units

Unless otherwise indicated, control terminals are single insulated and must not be touched.

**Isolation device**  
 The AC and / or DC power supply must be disconnected from the drive using an approved isolation device before any cover is removed from the drive or before any servicing work is performed.

**STOP function**  
 The STOP function does not remove dangerous voltages from the drive, the motor or any external option units.

**Stored charge**  
 The drive contains capacitors that remain charged to a potentially lethal voltage after the AC and / or DC power supply has been disconnected. If the drive has been energized, the AC and / or DC power supply must be isolated at least ten minutes before work may continue. Normally, the capacitors are discharged by an internal resistor. Under certain, unusual fault conditions, it is possible that the capacitors may fail to discharge, or be prevented from being discharged by a voltage applied to the output terminals. If the drive has failed in a manner that causes the display to go blank immediately, it is possible the capacitors will not be discharged. In this case, consult Control Techniques or their authorized distributor.

**Equipment supplied by plug and socket**  
 Special attention must be given if the drive is installed in equipment which is connected to the AC supply by a plug and socket. The AC supply terminals of the drive are connected to the internal capacitors through rectifier diodes which are not intended to give safety isolation. If the plug terminals can be touched when the plug is disconnected from the socket, a means of automatically isolating the plug from the drive must be used (e.g. a latching relay).

## 4.1 Power connections

### 4.1.1 AC and DC connections

Figure 4-1 Size 1 power connections

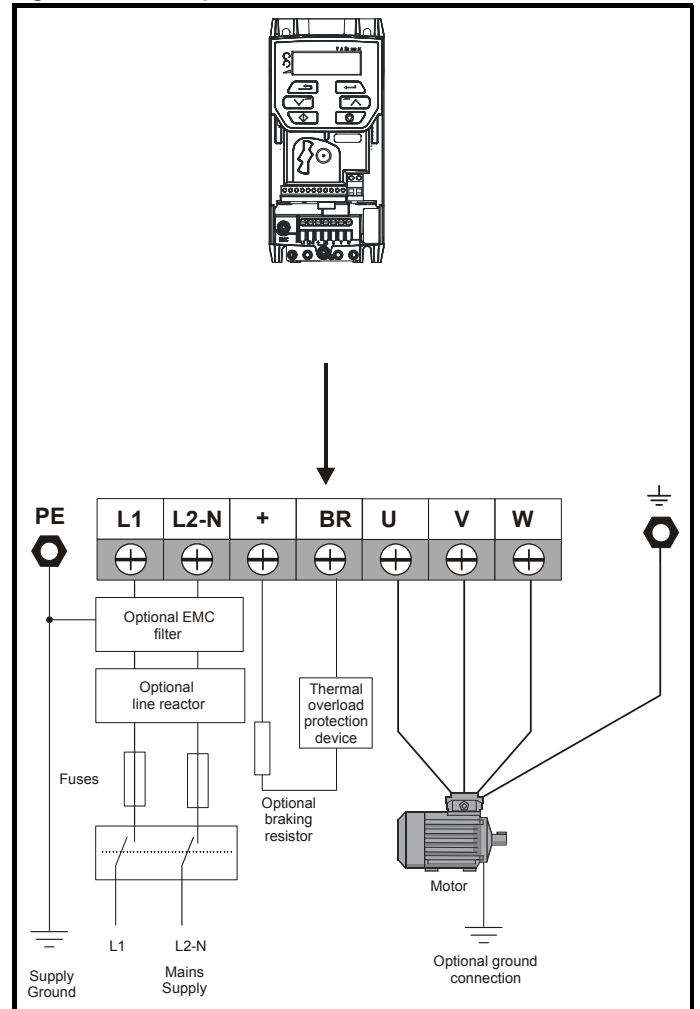

See Figure 4-5 Size 1 to 4 ground connections (size 2 shown) on page 32 for further information on ground connections.

**NOTE**

On the size 2 110 V drives, the supply should be connected to L1 and L3. Also the -DC Bus (-) terminal has no internal connection.

**Figure 4-2 Size 2 power connections**

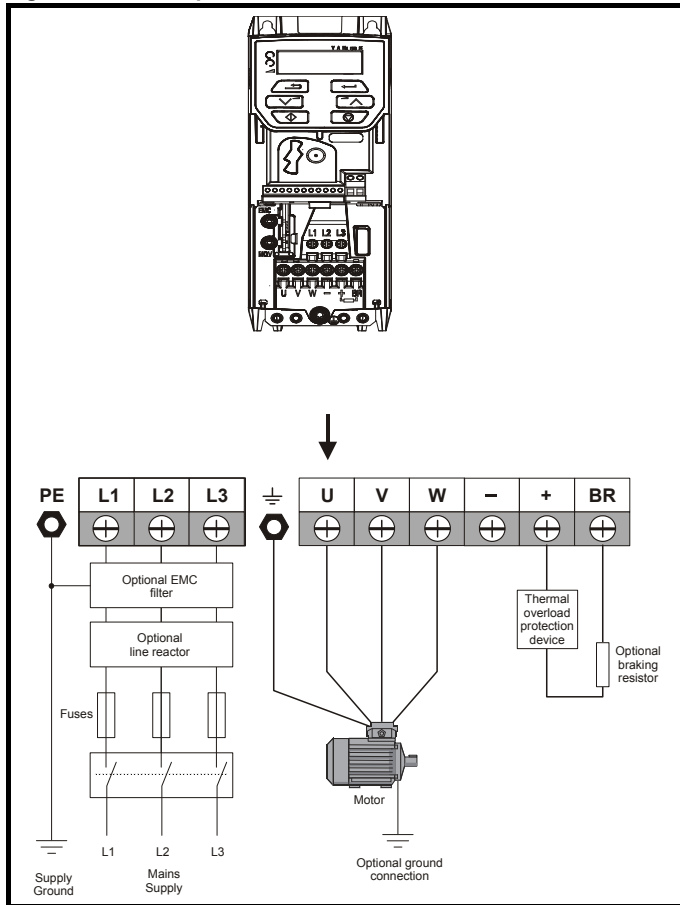

See Figure 4-5 *Size 1 to 4 ground connections (size 2 shown)* on page 32 for further information on ground connections.

**Figure 4-3 Size 3 power connections**

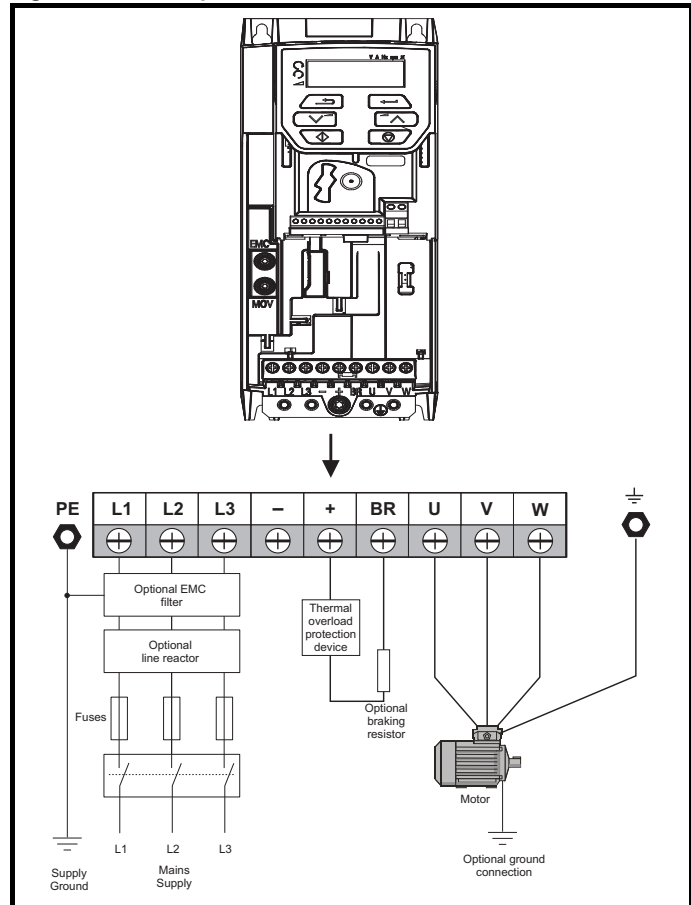

See Figure 4-5 *Size 1 to 4 ground connections (size 2 shown)* on page 32 for further information on ground connections.

**Figure 4-4 Size 4 power connections**

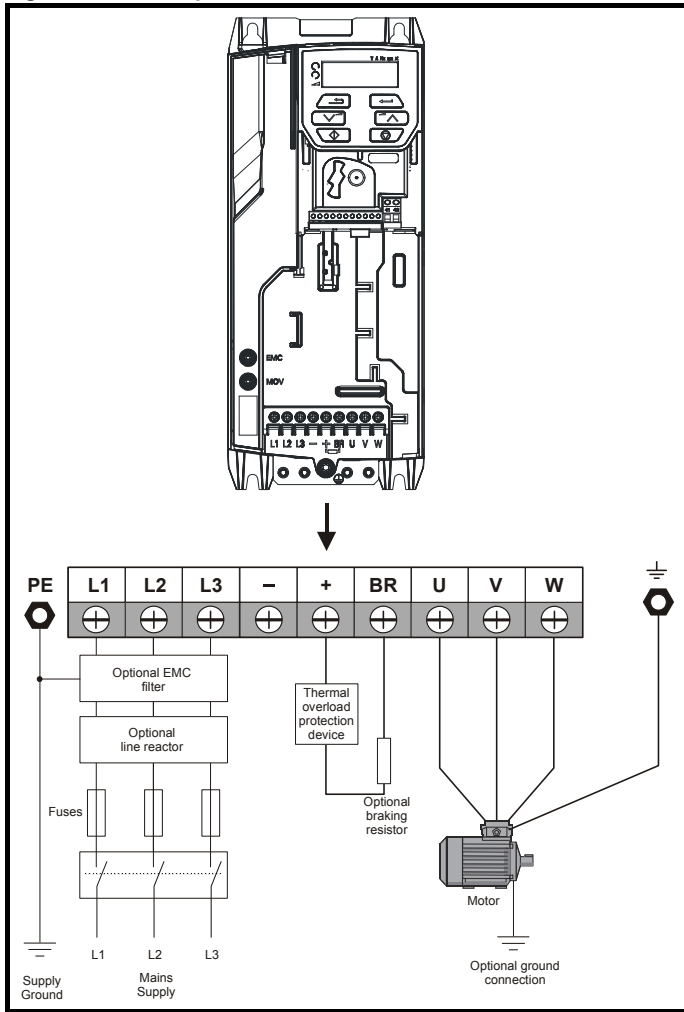

### 4.1.2 Ground connections



**Electrochemical corrosion of grounding terminals**  
Ensure that grounding terminals are protected against corrosion i.e. as could be caused by condensation.

#### Size 1 to 4

On sizes 1 to 4, the supply and motor ground connections are made using the ground connections located at the bottom of the drive as shown in Figure 4-5.

**Figure 4-5 Size 1 to 4 ground connections (size 2 shown)**

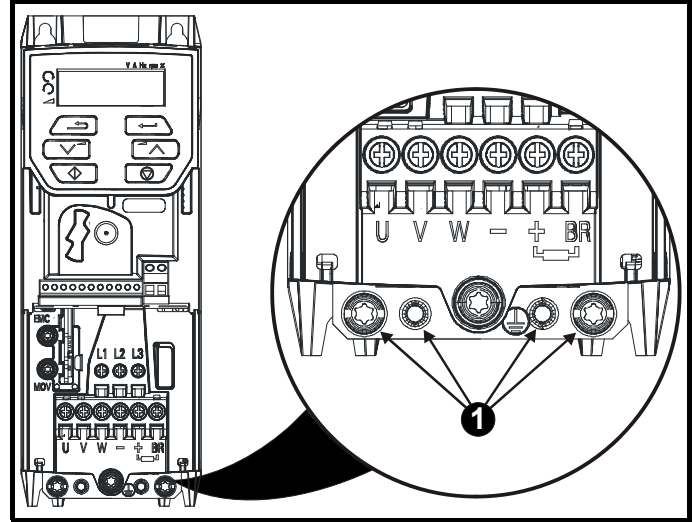

1: 4 x M4 threaded holes for the ground connection.



The ground loop impedance must conform to the requirements of local safety regulations.

The drive must be grounded by a connection capable of carrying the prospective fault current until the protective device (fuse, etc.) disconnects the AC supply.

The ground connections must be inspected and tested at appropriate intervals.

**Table 4-1 Protective ground cable ratings**

Input phase conductor size	Minimum ground conductor size
$\leq 10 \text{ mm}^2$	Either $10 \text{ mm}^2$ or two conductors of the same cross-sectional area as the input phase conductor.
$> 10 \text{ mm}^2$ and $\leq 16 \text{ mm}^2$	The same cross-sectional area as the first input phase conductor.
$> 16 \text{ mm}^2$ and $\leq 35 \text{ mm}^2$	$16 \text{ mm}^2$
$> 35 \text{ mm}^2$	Half of the cross-sectional area of the input phase conductor.



## 4.2 AC supply requirements

Voltage:

- 100 V drive: 100 V to 120 V ±10 %
- 200 V drive: 200 V to 240 V ±10 %
- 400 V drive: 380 V to 480 V ±10 %

Number of phases: 3

Maximum supply imbalance: 2 % negative phase sequence (equivalent to 3 % voltage imbalance between phases).

Frequency range: 48 to 62 Hz

For UL compliance only, the maximum supply symmetrical fault current must be limited to 100 kA

### 4.2.1 Supply types

All drives are suitable for use on any supply type i.e TN-S, TN-C-S, TT and IT.

- Supplies with voltage up to 600 V may have grounding at any potential, i.e. neutral, centre or corner ("grounded delta")
- Supplies with voltage above 600 V may not have corner grounding

Drives are suitable for use on supplies of installation category III and lower, according to IEC60664-1. This means they may be connected permanently to the supply at its origin in a building, but for outdoor installation additional over-voltage suppression (transient voltage surge suppression) must be provided to reduce category IV to category III.



#### Operation with IT (ungrounded) supplies:

Special attention is required when using internal or external EMC filters with ungrounded supplies, because in the event of a ground (earth) fault in the motor circuit the drive may not trip and the filter could be over-stressed. In this case, either the filter must not be used i.e. removed, or additional independent motor ground fault protection must be provided. For instructions on removal, refer to Figure 4-10 *Installation of grounding bracket* and Figure 4-13 *Removal of the size 3 internal EMC filter*. For details of ground fault protection contact the supplier of the drive.

A ground fault in the supply has no effect in any case. If the motor must continue to run with a ground fault in its own circuit, then an input isolating transformer must be provided, and if an EMC filter is required it must be located in the primary circuit.

Unusual hazards can occur on ungrounded supplies with more than one source, for example on ships. Contact the supplier of the drive for more information.

### 4.2.2 Supplies requiring line reactors

Input line reactors reduce the risk of damage to the drive resulting from poor phase balance or severe disturbances on the supply network.

Where line reactors are to be used, reactance values of approximately 2 % are recommended. Higher values may be used if necessary, but may result in a loss of drive output (reduced torque at high speed) because of the voltage drop.

For all drive ratings, 2 % line reactors permit drives to be used with a supply unbalance of up to 3.5 % negative phase sequence (equivalent to 5 % voltage imbalance between phases).

Severe disturbances may be caused by the following factors, for example:

- Power factor correction equipment connected close to the drive.
- Large DC drives having no or inadequate line reactors connected to the supply.
- Across the line (DOL) started motor(s) connected to the supply such that when any of these motors are started, the voltage dip exceeds 20 %.

Such disturbances may cause excessive peak currents to flow in the input power circuit of the drive. This may cause nuisance tripping, or in extreme cases, failure of the drive.

Drives of low power rating may also be susceptible to disturbance when connected to supplies with a high rated capacity.

Line reactors are particularly recommended for use with the following drive models when one of the above factors exists, or when the supply capacity exceeds 175 kVA.

Model sizes 04200133 to 04400170 have an internal DC choke so they do not require AC line reactors except for cases of excessive phase unbalance or extreme supply conditions.

When required, each drive must have its own reactor(s). Three individual reactors or a single three-phase reactor should be used.

### Reactor current ratings

The current rating of the line reactors should be as follows:

Continuous current rating:

Not less than the continuous input current rating of the drive

Repetitive peak current rating:

Not less than twice the continuous input current rating of the drive

### 4.2.3 Input inductor calculation

To calculate the inductance required (at Y%), use the following equation:

$$L = \frac{Y}{100} \times \frac{V}{\sqrt{3}} \times \frac{1}{2\pi f I}$$

Where:

I = drive rated input current (A)

L = inductance (H)

f = supply frequency (Hz)

V = voltage between lines

## 4.3 Ratings

The input current is affected by the supply voltage and impedance.

### Typical input current

The values of typical input current are given to aid calculations for power flow and power loss.

The values of typical input current are stated for a balanced supply.

### Maximum continuous input current

The values of maximum continuous input current are given to aid the selection of cables and fuses. These values are stated for the worst case condition with the unusual combination of stiff supply with bad balance. The value stated for the maximum continuous input current would only be seen in one of the input phases. The current in the other two phases would be significantly lower.

The values of maximum input current are stated for a supply with a 2 % negative phase-sequence imbalance and rated at the supply fault current given in Table 4-2.

Table 4-2 Supply fault current used to calculate maximum input currents

Model	Symmetrical fault level (kA)
All	100

 **Fuses**  
 The AC supply to the drive must be installed with suitable protection against overload and short-circuits. Table 4-3, Table 4-4 and Table 4-5 show the recommended fuse ratings. Failure to observe this requirement will cause risk of fire.

**WARNING**

**Table 4-3 AC Input current and fuse ratings (100 V)**

Model	Typical input current A	Maximum continuous input current A	Maximum overload input current A	Fuse rating	
				IEC gG Maximum A	Class CC or Class J Maximum A
				01100017	8.7
01100024	11.1	11.1	16	16	
02100042	18.8	18.8	20	20	
02100056	24.0	24.0	25	25	

**Table 4-4 AC Input current and fuse ratings (200 V)**

Model	Typical input current A	Maximum continuous input current A	Maximum overload input current A	Fuse rating			
				IEC gG Maximum A		Class CC or Class J Maximum A	
				1ph	3ph	1ph	3ph
				01200017	4.5	4.5	6
01200024	5.3	5.3			10		
01200033	8.3	8.3	10				
01200042	10.4	10.4	16		16		
02200024	5.3/3.2	5.3/4.1		6	10	5	
02200033	8.3/4.3	8.3/6.7		10		10	
02200042	10.4/5.4	10.4/7.5		16	10	16	10
02200056	14.9/7.4	14.9/11.3		20	16	20	16
02200075	18.1/9.1	18.1/13.5		25	20	25	20
03200100	23.9/12.8	23.9/17.7	30/25	25	20	25	20
04200133	23.7/13.5	23.7/16.9		25	20	25	20
04200176	17.0	21.3			25		25

**Table 4-5 AC Input current and fuse ratings (400 V)**

Model	Typical input current A	Maximum continuous input current A	Maximum overload input current A	Fuse rating	
				IEC gG Maximum A	Class CC or Class J Maximum A
				02400013	2.1
02400018	2.6	2.9			
02400023	3.1	3.5			
02400032	4.7	5.1			
02400041	5.8	6.2	10	10	
03400056	8.3	8.7	13	10	10
03400073	10.2	12.2	18	16	16
03400094	13.1	14.8	20.7	16	20
04400135	14.0	16.3		20	20
04400170	18.5	20.7		25	25

**NOTE**

Ensure cables used suit local wiring regulations.



The nominal cable sizes below are only a guide. The mounting and grouping of cables affects their current-carrying capacity, in some cases smaller cables may be acceptable but in other cases a larger cable is required to avoid excessive temperature or voltage drop. Refer to local wiring regulations for the correct size of cables.

**Table 4-6 Cable ratings (100 V)**

Model	Cable size (IEC 60364-5-52) mm <sup>2</sup>				Cable size (UL508C) AWG			
	Input		Output		Input		Output	
	Nominal	Maximum	Nominal	Maximum	Nominal	Maximum	Nominal	Maximum
01100017	1	6	1	2.5	16	10	16	12
01100024	1.5	6	1	2.5	14	10	16	12
02100042	2.5	6	1	2.5	12	10	16	12
02100056	4	6	1	2.5	10	10	16	12

**Table 4-7 Cable ratings (200 V)**

Model	Cable size (IEC 60364-5-52) mm <sup>2</sup>				Cable size (UL 508C) AWG			
	Input		Output		Input		Output	
	Nominal	Maximum	Nominal	Maximum	Nominal	Maximum	Nominal	Maximum
01200017	1	6	1	2.5	16	10	16	12
01200024	1	6	1	2.5	16	10	16	12
01200033	1	6	1	2.5	16	10	16	12
01200042	1	6	1	2.5	16	10	16	12
02200024	1	6	1	2.5	16	10	16	12
02200033	1	6	1	2.5	16	10	16	12
02200042	1	6	1	2.5	16	10	16	12
02200056	2.5/1.5	6	1	2.5	12/14	10	16	12
02200075	2.5	6	1	2.5	12	10	16	12
03200100	4	6	1.5	2.5	10/12	10	14	12
04200133	4/2.5	6	2.5	2.5	10	10	12	12
04200176	4	6	2.5	2.5	10	10	12	12

**Table 4-8 Cable ratings (400 V)**

Model	Cable size (IEC 60364-5-52) mm <sup>2</sup>				Cable size (UL 508C) AWG			
	Input		Output		Input		Output	
	Nominal	Maximum	Nominal	Maximum	Nominal	Maximum	Nominal	Maximum
02400013	1	6	1	2.5	16	10	16	12
02400018	1	6	1	2.5	16	10	16	12
02400023	1	6	1	2.5	16	10	16	12
02400032	1	6	1	2.5	16	10	16	12
02400041	1	6	1	2.5	16	10	16	12
03400056	1	6	1	2.5	14	10	16	12
03400073	1.5	6	1	2.5	12	10	16	12
03400094	2.5	6	1.5	2.5	12	10	14	12
04400135	2.5	6	2.5	2.5	10	10	12	12
04400170	4	6	2.5	2.5	10	10	12	12

**NOTE**  
PVC insulated cable should be used.

**NOTE**  
Cable sizes are from IEC60364-5-52:2001 table A.52.C with correction factor for 40°C ambient of 0.87 (from table A52.14) for cable installation method B2 (multicore cable in conduit).

**Installation class (ref: IEC60364-5-52:2001)**

- B1 - Separate cables in conduit.
- B2 - Multicore cable in conduit.
- C - Multicore cable in free air.

Cable size may be reduced if a different installation method is used, or if the ambient temperature is lower.

**NOTE**

The nominal output cable sizes assume that the motor maximum current matches that of the drive. Where a motor of reduced rating is used the cable rating may be chosen to match that of the motor. To ensure that the motor and cable are protected against overload, the drive must be programmed with the correct motor rated current.

A fuse or other protection must be included in all live connections to the AC supply.

**Fuse types**

The fuse voltage rating must be suitable for the drive supply voltage.

**MCB**

Do not use an MCB instead of the recommended fuses.

**Ground connections**

The drive must be connected to the system ground of the AC supply. The ground wiring must conform to local regulations and codes of practice.

**NOTE**

For information on ground cable sizes, refer to Table 4-1 *Protective ground cable ratings* on page 32.

**4.3.1 Main AC supply contactor**

The recommended AC supply contactor type for size 1 to 4 is AC1.

**4.4 Output circuit and motor protection**

The output circuit has fast-acting electronic short-circuit protection which limits the fault current to typically no more than 2.5 times the rated output current, and interrupts the current in approximately 20 μs. No additional short-circuit protection devices are required.

The drive provides overload protection for the motor and its cable. For this to be effective, *Rated Current (00.006)* must be set to suit the motor.



*Motor Rated Current (00.006)* must be set correctly to avoid a risk of fire in the event of motor overload.

**WARNING**

**4.4.1 Cable types and lengths**

Since capacitance in the motor cable causes loading on the output of the drive, ensure the cable length does not exceed the values given in Table 4-9, Table 4-10 and Table 4-11.

Use 105 °C (221 °F) (UL 60/75 °C temp rise) PVC-insulated cable with copper conductors having a suitable voltage rating, for the following power connections:

- AC supply to external EMC filter (when used)
- AC supply (or external EMC filter) to drive
- Drive to motor
- Drive to braking resistor

**Table 4-9 Maximum motor cable lengths (100 V drives)**

Model	100 V Nominal AC supply voltage								
	Maximum permissible motor cable length for each of the following switching frequencies								
	0.667 kHz	1 kHz	2 kHz	3 kHz	4 kHz	6 kHz	8 kHz	12 kHz	16 kHz
01100017	50 m (164 ft)				37.5 m (123 ft)	25 m (82 ft)	18.75 m (61 ft)	12.5 m (41 ft)	9 m (30 ft)
01100024	50 m (164 ft)				37.5 m (123 ft)	25 m (82 ft)	18.75 m (61 ft)	12.5 m (41 ft)	9 m (30 ft)
02100042	100 m (328 ft)				75 m (246 ft)	50 m (164 ft)	37.5 m (123 ft)	25 m (82 ft)	18 m (59 ft)
02100056	100 m (328 ft)				75 m (246 ft)	50 m (164 ft)	37.5 m (123 ft)	25 m (82 ft)	18 m (59 ft)

**Table 4-10 Maximum motor cable lengths (200 V drives)**

Model	200 V Nominal AC supply voltage								
	Maximum permissible motor cable length for each of the following switching frequencies								
	0.667 kHz	1 kHz	2 kHz	3 kHz	4 kHz	6 kHz	8 kHz	12 kHz	16 kHz
01200017	50 m (164 ft)				37.5 m (123 ft)	25 m (82 ft)	18.75 m (61 ft)	12.5 m (41 ft)	9 m (30 ft)
01200024									
01200033									
01200042									
02200024	100 m (328 ft)				75 m (246 ft)	50 m (164 ft)	37.5 m (123 ft)	25 m (82 ft)	18 m (59 ft)
02200033									
02200042									
02200056									
02200075									
03200100	100 m (328 ft)				75 m (246 ft)	50 m (164 ft)	37.5 m (123 ft)	25 m (82 ft)	18 m (59 ft)
04200133	100 m (328 ft)				75 m (246 ft)	50 m (164 ft)	37.5 m (123 ft)	25 m (82 ft)	18 m (59 ft)
04200176									

**Table 4-11 Maximum motor cable lengths (400 V drives)**

Model	400 V Nominal AC supply voltage								
	Maximum permissible motor cable length for each of the following switching frequencies								
	0.667 kHz	1 kHz	2 kHz	3 kHz	4 kHz	6 kHz	8 kHz	12 kHz	16 kHz
02400013	100 m (328 ft)				75 m (246 ft)	50 m (164 ft)	37.5 m (123 ft)	25 m (82 ft)	18.25 m (61 ft)
02400018									
02400023									
02400032									
02400041									
03400056	100 m (328 ft)				75 m (246 ft)	50 m (164 ft)	37.5 m (123 ft)	25 m (82 ft)	18.25 m (61 ft)
03400073									
03400094									
04400135	100 m (328 ft)				75 m (246 ft)	50 m (164 ft)	37.5 m (123 ft)	25 m (82 ft)	18.25 m (61 ft)
04400170									

#### 4.4.2 High-capacitance / reduced diameter cables

The maximum cable length is reduced from that shown in Table 4-9, Table 4-10 and Table 4-11, if high capacitance or reduced diameter motor cables are used.

Most cables have an insulating jacket between the cores and the armor or shield; these cables have a low capacitance and are recommended. Cables that do not have an insulating jacket tend to have high capacitance; if a cable of this type is used, the maximum cable length is half that quoted in the tables, (Figure 4-6 shows how to identify the two types).

**Figure 4-6 Cable construction influencing the capacitance**

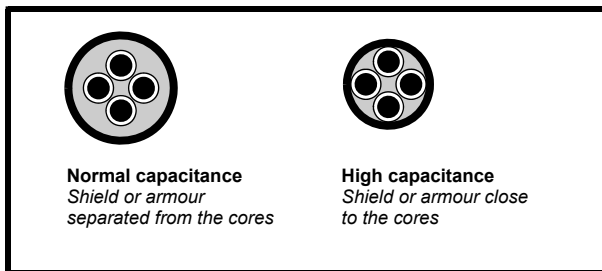

The cable used for Table 4-9, Table 4-10 and Table 4-11 is shielded and contains four cores. Typical capacitance for this type of cable is 130 pF/m (i.e. from one core to all others and the shield connected together).

#### 4.4.3 Motor winding voltage

The PWM output voltage can adversely affect the inter-turn insulation in the motor. This is because of the high rate of change of voltage, in conjunction with the impedance of the motor cable and the distributed nature of the motor winding.

For normal operation with AC supplies up to 500 Vac and a standard motor with a good quality insulation system, there is no need for any special precautions. In case of doubt the motor supplier should be consulted. Special precautions are recommended under the following conditions, but only if the motor cable length exceeds 10 m:

- AC supply voltage exceeds 500 V
- DC supply voltage exceeds 670 V
- Operation of 400 V drive with continuous or very frequent sustained braking
- Multiple motors connected to a single drive

For multiple motors, the precautions given in section 4.4.4 *Multiple motors* on page 38 should be followed.

For the other cases listed, it is recommended that an inverter-rated motor be used taking into account the voltage rating of the inverter. This has a reinforced insulation system intended by the manufacturer for repetitive fast-rising pulsed voltage operation.

Users of 575 V NEMA rated motors should note that the specification for inverter-rated motors given in NEMA MG1 section 31 is sufficient for motoring operation but not where the motor spends significant periods braking. In that case an insulation peak voltage rating of 2.2 kV is recommended.

If it is not practical to use an inverter-rated motor, an output choke (inductor) should be used. The recommended type is a simple iron-cored component with a reactance of about 2 %. The exact value is not critical. This operates in conjunction with the capacitance of the motor cable to increase the rise-time of the motor terminal voltage and prevent excessive electrical stress.

#### 4.4.4 Multiple motors

If the drive is to control more than one motor, one of the fixed V/F modes should be selected (Pr 05.014 = Fixed or Squared). Make the motor connections as shown in Figure 4-7 and Figure 4-8. The maximum cable lengths in Table 4-9, Table 4-10 and Table 4-11 apply to the sum of the total cable lengths from the drive to each motor.

It is recommended that each motor is connected through a protection relay since the drive cannot protect each motor individually. For  $\Delta$  connection, a sinusoidal filter or an output inductor must be connected as shown in Figure 4-8, even when the cable lengths are less than the maximum permissible. For details of inductor sizes refer to the supplier of the drive.

Figure 4-7 Preferred chain connection for multiple motors

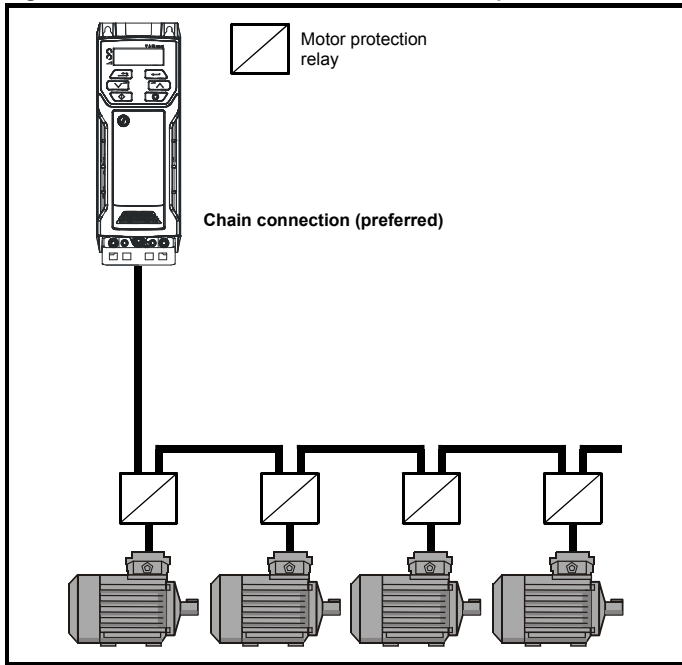
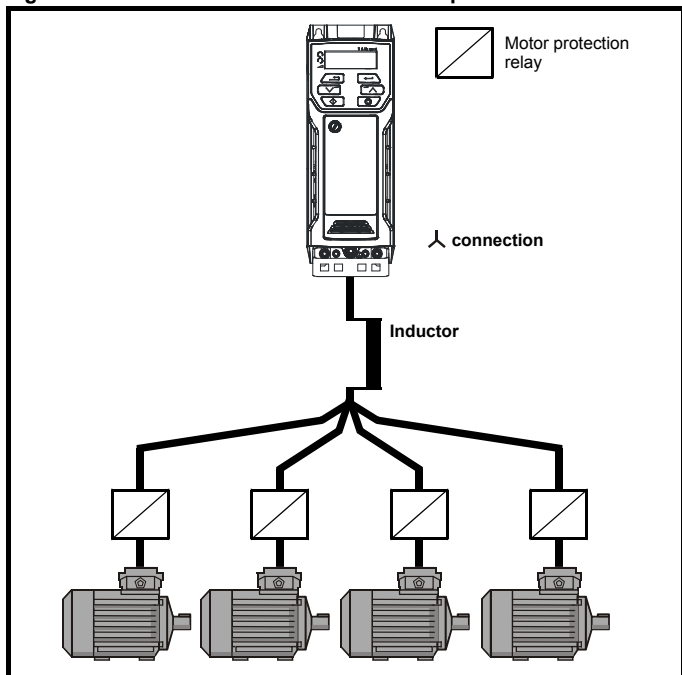

Figure 4-8 Alternative connection for multiple motors



#### 4.4.5 $\Delta$ / $\Delta$ motor operation

The voltage rating for  $\Delta$  and  $\Delta$  connections of the motor should always be checked before attempting to run the motor.

The default setting of the motor rated voltage parameter is the same as the drive rated voltage, i.e.

- 400 V drive 400 V rated voltage
- 230 V drive 230 V rated voltage

A typical 3 phase motor would be connected in  $\Delta$  for 400 V operation or  $\Delta$  for 230 V operation, however, variations on this are common e.g.

$\Delta$  690 V  $\Delta$  400 V.

Incorrect connection of the windings will cause severe under or over fluxing of the motor, leading to a very poor output torque or motor saturation and overheating respectively.

#### 4.4.6 Output contactor



If the cable between the drive and the motor is to be interrupted by a contactor or circuit breaker, ensure that the drive is disabled before the contactor or circuit breaker is opened or closed. Severe arcing may occur if this circuit is interrupted with the motor running at high current and low speed.

A contactor is sometimes required to be installed between the drive and motor for safety purposes.

The recommended motor contactor is the AC3 type.

Switching of an output contactor should only occur when the output of the drive is disabled.

Opening or closing of the contactor with the drive enabled will lead to:

1. OI ac trips (which cannot be reset for 10 seconds)
2. High levels of radio frequency noise emission
3. Increased contactor wear and tear

## 4.5 Braking

Braking occurs when the drive is decelerating the motor, or is preventing the motor from gaining speed due to mechanical influences. During braking, energy is returned to the drive from the motor.

When motor braking is applied by the drive, the maximum regenerated power that the drive can absorb is equal to the power dissipation (losses) of the drive.

When the regenerated power is likely to exceed these losses, the DC bus voltage of the drive increases. Under default conditions, the drive brakes the motor under PI control, which extends the deceleration time as necessary in order to prevent the DC bus voltage from rising above a user defined set-point.

If the drive is expected to rapidly decelerate a load, or to hold back an overhauling load, a braking resistor must be installed.

Table 4-12 shows the default DC voltage level at which the drive turns on the braking transistor. However the braking resistor turn on and the turn off voltages are programmable with *Braking IGBT Lower Threshold* (06.073) and *Braking IGBT Upper Threshold* (06.074).

**Table 4-12 Default braking transistor turn on voltage**

Drive voltage rating	DC bus voltage level
100 & 200 V	390 V
400 V	780 V

### NOTE

When a braking resistor is used, Pr **02.004** should be set to Fast ramp mode.



#### High temperatures

Braking resistors can reach high temperatures. Locate braking resistors so that damage cannot result. Use cable having insulation capable of withstanding high temperatures.



#### Braking resistor overload protection parameter settings

Failure to observe the following information may damage the resistor.

The drive software contains an overload protection function for a braking resistor.

For more information on the braking resistor software overload protection, see Pr **10.030**, Pr **10.031** and Pr **10.061** full descriptions in the *Parameter Reference Guide*.

### 4.5.1 External braking resistor



#### Overload protection

When an external braking resistor is used, it is essential that an overload protection device is incorporated in the braking resistor circuit; this is described in Figure 4-9 on page 40.

When a braking resistor is to be mounted outside the enclosure, ensure that it is mounted in a ventilated metal housing that will perform the following functions:

- Prevent inadvertent contact with the resistor
- Allow adequate ventilation for the resistor

When compliance with EMC emission standards is required, external connection requires the cable to be armored or shielded, since it is not fully contained in a metal enclosure. See section 4.7.5 *Compliance with generic emission standards* on page 44 for further details.

Internal connection does not require the cable to be armored or shielded.

### Minimum resistances and power ratings

**Table 4-13 Minimum resistance values and peak power rating for the braking resistor at 40 °C (104 °F)**

Model	Minimum resistance* Ω	Instantaneous power rating kW	Continuous power rating kW
<b>100 V</b>			
01100017	130	1.2	
01100024	130	1.2	
02100042	68	2.2	
02100056	68	2.2	
<b>200 V</b>			
01200017	130	1.2	
01200024	130	1.2	
01200033	130	1.2	
01200042	130	1.2	
02200024	68	2.2	
02200033	68	2.2	
02200042	68	2.2	
02200056	68	2.2	
02200075	68	2.2	
03200100	45	3.4	2.2
04200133	22	6.9	
04200176	22	6.9	
<b>400 V</b>			
02400013	270	2.3	
02400018	270	2.3	
02400023	270	2.3	
02400032	270	2.3	
02400041	270	2.3	
03400056	100	6.1	2.2
03400073	100	6.1	3
03400094	100	6.1	4
04400135	50	12.2	
04400170	50	12.2	

\* Resistor tolerance: ±10 %

For high-inertia loads or under continuous braking, the *continuous power* dissipated in the braking resistor may be as high as the power rating of the drive. The total *energy* dissipated in the braking resistor is dependent on the amount of energy to be extracted from the load.

The instantaneous power rating refers to the short-term maximum power dissipated during the *on* intervals of the pulse width modulated braking control cycle. The braking resistor must be able to withstand this dissipation for short intervals (milliseconds). Higher resistance values require proportionately lower instantaneous power ratings.

In most applications, braking occurs only occasionally. This allows the continuous power rating of the braking resistor to be much lower than the power rating of the drive. It is therefore essential that the instantaneous power rating and energy rating of the braking resistor are sufficient for the most extreme braking duty that is likely to be encountered.

Optimization of the braking resistor requires careful consideration of the braking duty.

Select a value of resistance for the braking resistor that is not less than the specified minimum resistance. Larger resistance values may give a cost saving, as well as a safety benefit in the event of a fault in the braking system. Braking capability will then be reduced, which could cause the drive to trip during braking if the value chosen is too large.

### Thermal protection circuit for the braking resistor

The thermal protection circuit must disconnect the AC supply from the drive if the resistor becomes overloaded due to a fault. Figure 4-9 shows a typical circuit arrangement.

**Figure 4-9 Typical protection circuit for a braking resistor**

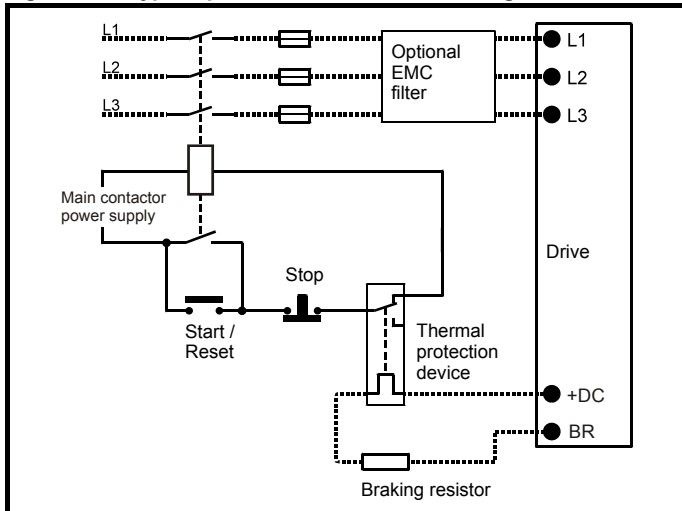

See Figure 4-1 on page 30 and Figure 4-4 on page 32 for the location of the +DC and braking resistor connections.

### 4.5.2 Braking resistor software overload protection

The drive software contains an overload protection function for a braking resistor. In order to enable and set-up this function, it is necessary to enter three values into the drive:

- *Braking Resistor Rated Power* (10.030)
- *Braking Resistor Thermal Time Constant* (10.031)
- *Braking Resistor Resistance* (10.061)

This data should be obtained from the manufacturer of the braking resistors.

Pr **10.039** gives an indication of braking resistor temperature based on a simple thermal model. Zero indicates the resistor is close to ambient and 100 % is the maximum temperature the resistor can withstand. A br.rES alarm is given if this parameter is above 75 % and the braking IGBT is active. An It.br trip will occur if Pr **10.039** reaches 100 %, when Pr **10.037** is set to 0 (default value) or 1.

If Pr **10.037** is equal to 2 or 3, an It.br trip will not occur when Pr **10.039** reaches 100 %, but instead the braking IGBT will be disabled until Pr **10.039** falls below 95 %. This option is intended for applications with parallel connected DC buses where there are several braking resistors, each of which cannot withstand full DC bus voltage continuously. With this type of application it is unlikely the braking energy will be shared equally between the resistors because of voltage measurement tolerances within the individual drives. Therefore with Pr **10.037** set to 2 or 3, then as soon as a resistor has reached its maximum temperature the drive will disable the braking IGBT, and another resistor on another drive will take up the braking energy. Once Pr **10.039** has fallen below 95 % the drive will allow the braking IGBT to operate again.

See the *Parameter Reference Guide* for more information on Pr **10.030**, Pr **10.031**, Pr **10.037** and Pr **10.039**.

This software overload protection should be used in addition to an external overload protection device.

## 4.6 Ground leakage

The ground leakage current depends upon whether the internal EMC filter is installed or not. The drive is supplied with the filter installed. Instructions for removing the internal filter are given in section 4.7.2 *Internal EMC filter* on page 41.

### With internal filter installed:

**Size 1:** 2.5 mA\* AC at 230 V 50 Hz (line to line supply, star point ground)  
9.2 mA\* AC at 230 V 50 Hz (line to neutral supply, star point ground)

**Size 3:** 19.7 mA\* AC at 400 V 50 Hz (star point ground)  
47.4 mA\* AC at 400 V 50 Hz (corner ground)

**Size 4:** 21 mA\* AC at 230 V 50 Hz (3 phase, star point ground)  
6.8 mA\* AC at 230 V 50 Hz (1 phase, line to line supply, star point ground)  
30 mA\* AC at 230 V 50 Hz (1 phase, line to neutral supply, star point ground)  
50 mA\* AC at 400 V 50 Hz (3 phase, star point ground)

\* Proportional to the supply voltage and frequency.

### With internal filter removed:

**Size 1:** <1.5 mA (line to line supply, star point ground)  
<1 mA (line to neutral supply, star point ground)

**Size 3:** <3.3 mA (star point ground)  
<4.9 mA (corner ground)

**Size 4:** < 3.5 mA (star point ground)

### NOTE

The above leakage currents are just the leakage currents of the drive with the internal EMC filter connected and do not take into account any leakage currents of the motor or motor cable.



When the internal filter is installed the leakage current is high. In this case a permanent fixed ground connection must be provided, or other suitable measures taken to prevent a safety hazard occurring if the connection is lost.



When the leakage current exceeds 3.5 mA, a permanent fixed ground connection must be provided using two independent conductors each with a cross-section equal to or exceeding that of the supply conductors. The drive is provided with two ground connections to facilitate this. Both ground connections are necessary to meet EN 61800-5-1: 2007.

### 4.6.1 Use of residual current device (RCD)

There are three common types of ELCB / RCD:

1. AC - detects AC fault currents
2. A - detects AC and pulsating DC fault currents (provided the DC current reaches zero at least once every half cycle)
3. B - detects AC, pulsating DC and smooth DC fault currents
  - Type AC should never be used with drives.
  - Type A can only be used with single phase drives
  - Type B must be used with three phase drives



Only type B ELCB / RCD are suitable for use with 3 phase inverter drives.

If an external EMC filter is used, a delay of at least 50 ms should be incorporated to ensure spurious trips are not seen. The leakage current is likely to exceed the trip level if all of the phases are not energized simultaneously.



## 4.7 EMC (Electromagnetic compatibility)

The requirements for EMC are divided into three levels in the following three sections:

**Section 4.10.3, General requirements** for all applications, to ensure reliable operation of the drive and minimise the risk of disturbing nearby equipment. The immunity standards specified in Chapter 11 *Technical data* on page 103 will be met, but no specific emission standards are applied. Note also the special requirements given in *Surge immunity of control circuits - long cables and connections outside a building* on page 46 for increased surge immunity of control circuits where control wiring is extended.

**Section 4.7.4, Requirements for meeting the EMC standard for power drive systems, IEC61800-3 (EN 61800-3:2004).**

**Section 4.7.5, Requirements for meeting the generic emission standards** for the industrial environment, IEC61000-6-4, EN 61000-6-4:2007.

The recommendations of section 4.7.3 will usually be sufficient to avoid causing disturbance to adjacent equipment of industrial quality. If particularly sensitive equipment is to be used nearby, or in a non-industrial environment, then the recommendations of section 4.7.4 or section 4.7.5 should be followed to give reduced radio-frequency emission.

In order to ensure the installation meets the various emission standards described in:

- The EMC data sheet available from the supplier of the drive
- The Declaration of Conformity at the front of this manual
- Chapter 11 *Technical data* on page 103

The correct external EMC filter must be used and all of the guidelines in section 4.7.3 *General requirements for EMC* on page 43 and section 4.7.5 *Compliance with generic emission standards* on page 44 must be followed.

**Table 4-14 Drive and EMC filter cross reference**

Model	CT part number
<b>200 V</b>	
<b>400 V</b>	



### High ground leakage current

When an EMC filter is used, a permanent fixed ground connection must be provided which does not pass through a connector or flexible power cord. This includes the internal EMC filter.

### NOTE

The installer of the drive is responsible for ensuring compliance with the EMC regulations that apply in the country in which the drive is to be used.

### 4.7.1 Grounding hardware

The drive is supplied with a grounding bracket to facilitate EMC compliance. This provides a convenient method for direct grounding of cable shields without the use of "pig-tails". Cable shields can be bared and clamped to the grounding bracket using metal clips or clamps<sup>1</sup> (not supplied) or cable ties. Note that the shield must in all cases be continued through the clamp to the intended terminal on the drive, in accordance with the connection details for the specific signal.

<sup>1</sup> A suitable clamp is the Phoenix DIN rail mounted SK14 cable clamp (for cables with a maximum outer diameter of 14 mm).

See Figure 4-10 for details regarding the installation of the grounding bracket.

**Figure 4-10 Installation of grounding bracket**

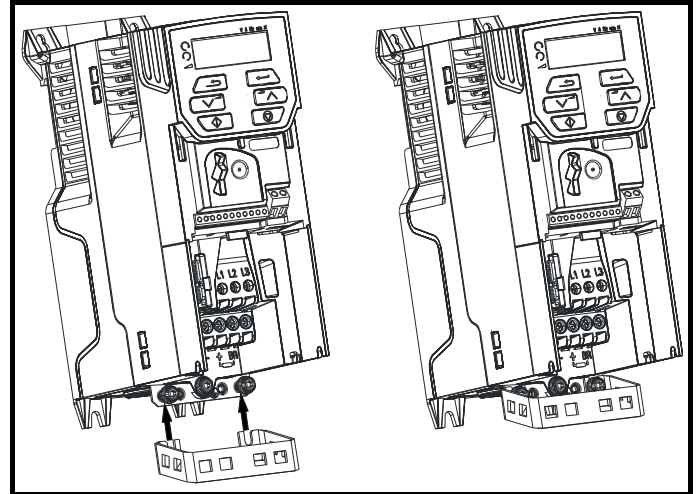

### 4.7.2 Internal EMC filter

It is recommended that the internal EMC filter be kept in place unless there is a specific reason for removing it.

If the drive is used as a motoring drive as part of a regen system, then the internal EMC filter must be removed.

The internal EMC filter reduces radio-frequency emission into the line power supply. Where the motor cable is short, it permits the requirements of EN 61800-3:2004 to be met for the second environment - see section 4.7.4 *Compliance with EN 61800-3:2004 (standard for Power Drive Systems)* on page 44 and section 11.1.25 *Electromagnetic compatibility (EMC)* on page 113. For longer motor cables the filter continues to provide a useful reduction in emission levels, and when used with any length of shielded motor cable up to the limit for the drive, it is unlikely that nearby industrial equipment will be disturbed. It is recommended that the filter be used in all applications unless the instructions given above require it to be removed, or where the ground leakage current of 28 mA for size 1 is unacceptable. As shown in Figure 4-11 to Figure 4-14 the size 1 internal EMC filter is removed by removing the screw (1).



The supply must be disconnected before removing the internal EMC filter.

**Figure 4-11 Removal of the size 1 internal EMC filter**

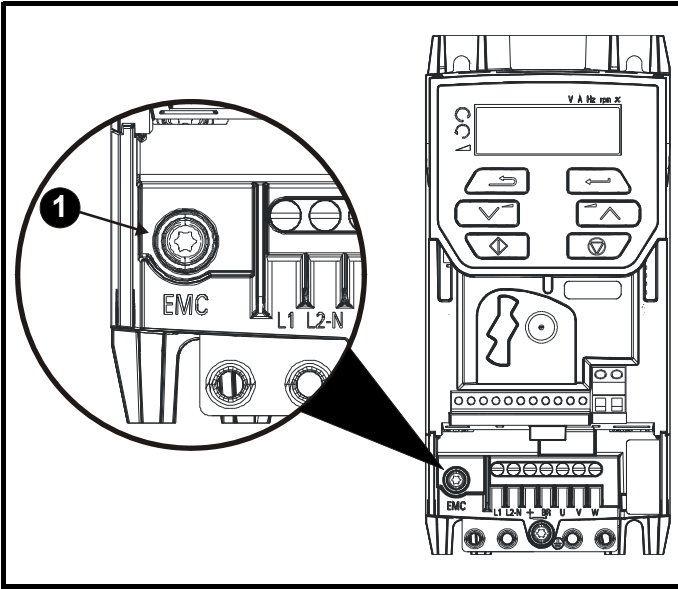

To electrically disconnect the internal EMC filter, remove the screw as shown above (1).

**Figure 4-12 Removal of the size 2 internal EMC filter**

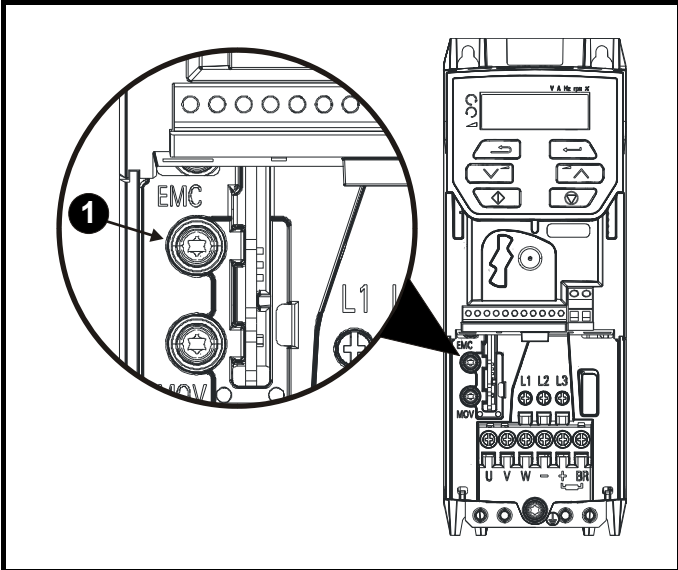

To electrically disconnect the internal EMC filter, remove the screw as shown above (1).

**Figure 4-13 Removal of the size 3 internal EMC filter**

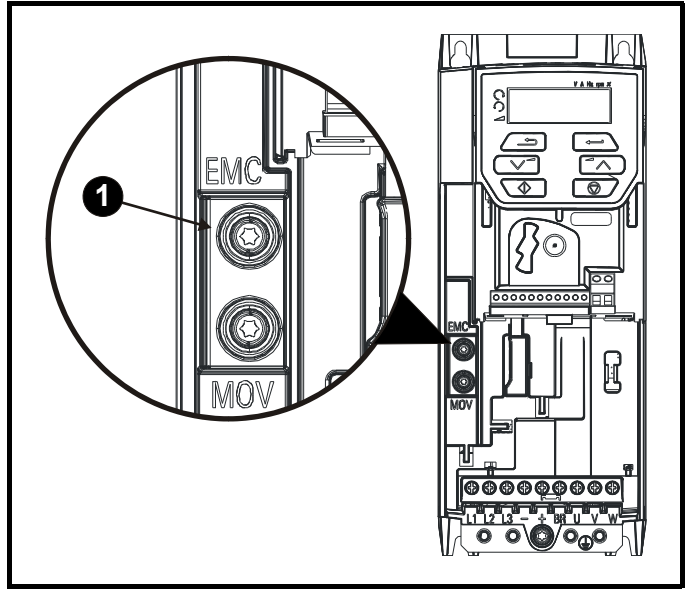

To electrically disconnect the internal EMC filter, remove the screw as shown above (1).

**Figure 4-14 Removal of the size 4 internal EMC filter**

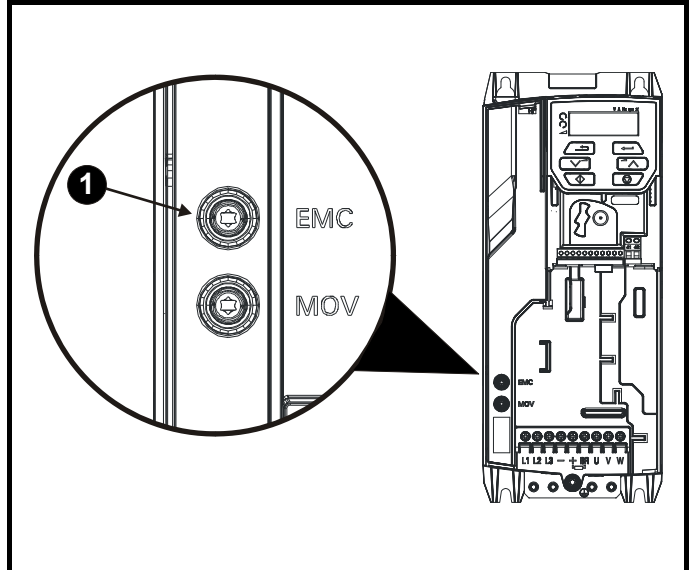

To electrically disconnect the internal EMC filter, remove the screw as shown above (1).

### 4.7.3 General requirements for EMC

#### Ground (earth) connections

The grounding arrangements should be in accordance with Figure 4-15, which shows a single drive on a back-plate with or without an additional enclosure.

Figure 4-15 shows how to configure and minimise EMC when using unshielded motor cable. However shielded cable is a better option, in which case it should be installed as shown in section 4.7.5 *Compliance with generic emission standards* on page 44.

**Figure 4-15 General EMC enclosure layout showing ground connections**

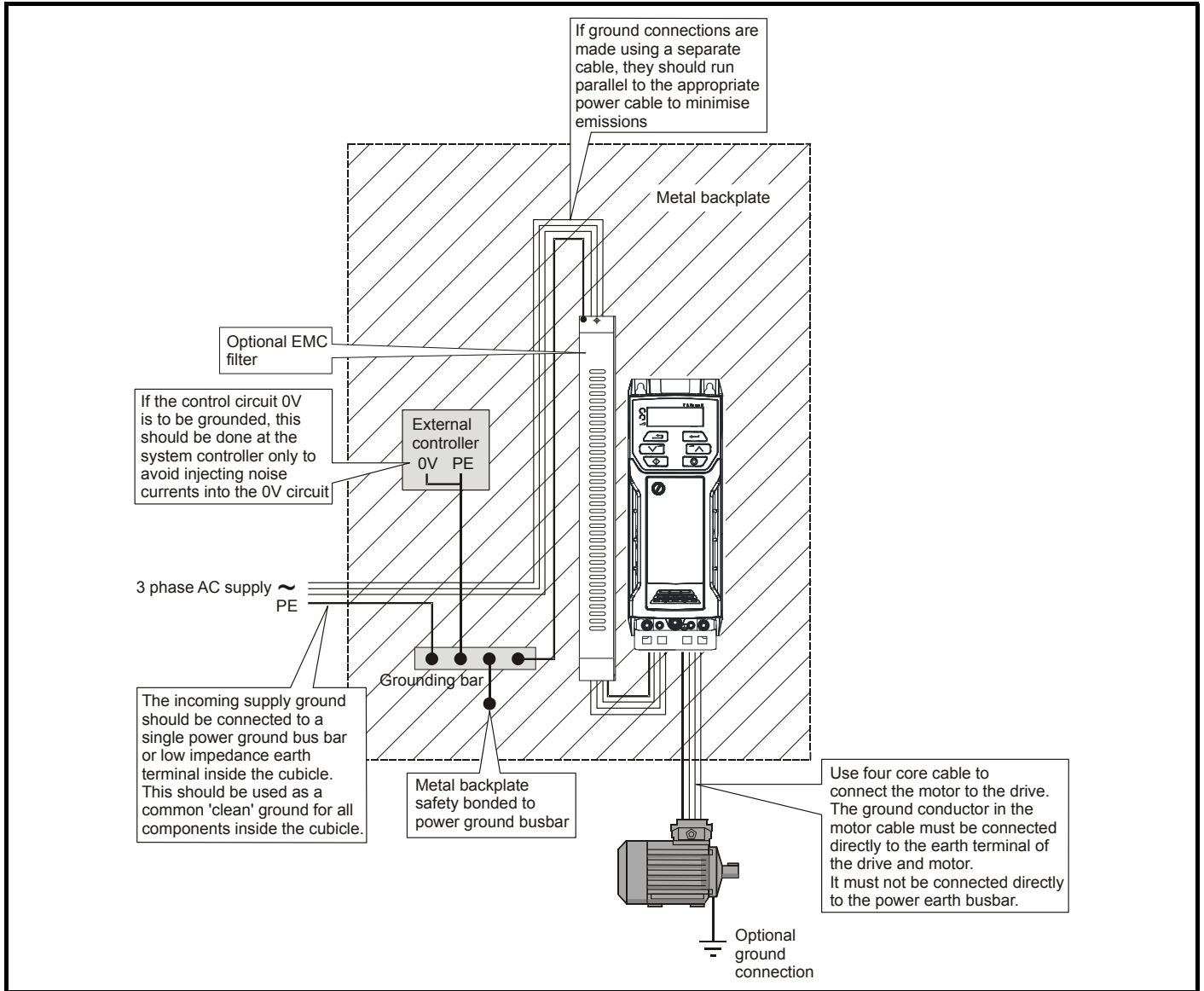

### Cable layout

Figure 4-16 indicates the clearances which should be observed around the drive and related 'noisy' power cables by all sensitive control signals / equipment.

**Figure 4-16 Drive cable clearances**

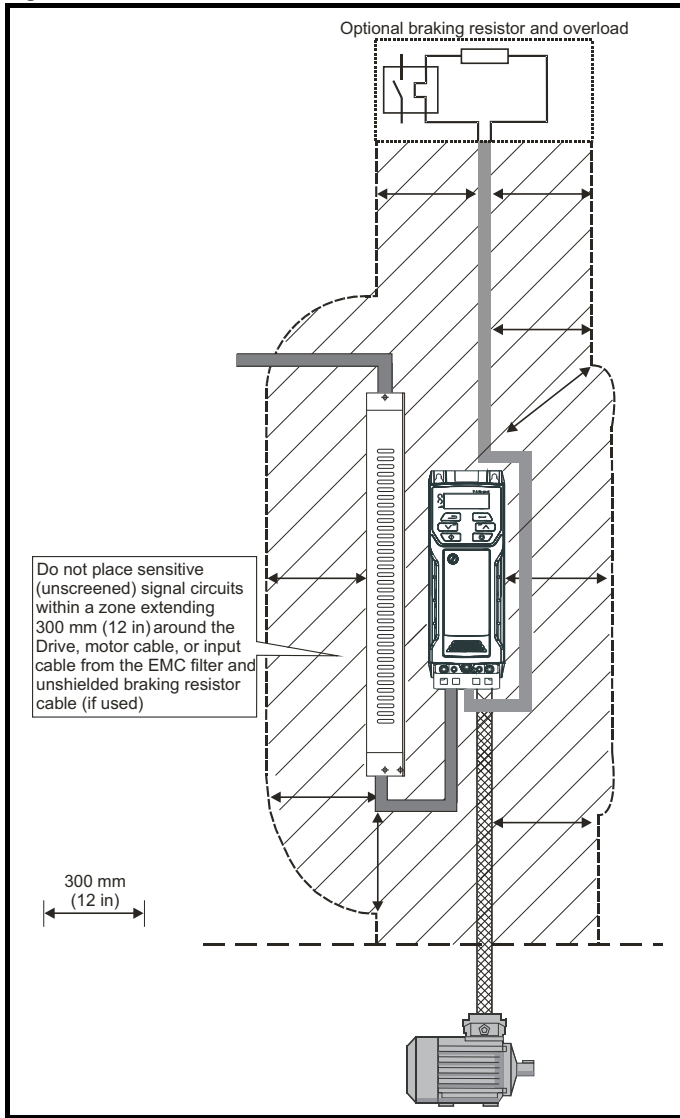

**NOTE**

Any signal cables which are carried inside the motor cable (i.e. motor thermistor, motor brake) will pick up large pulse currents via the cable capacitance. The shield of these signal cables must be connected to ground close to the motor cable, to avoid this noise current spreading through the control system.

### 4.7.4 Compliance with EN 61800-3:2004 (standard for Power Drive Systems)

Meeting the requirements of this standard depends on the environment that the drive is intended to operate in, as follows:

#### Operation in the first environment

Observe the guidelines given in section 4.7.5 *Compliance with generic emission standards* on page 44. An external EMC filter will always be required.

This is a product of the restricted distribution class according to IEC 61800-3  
 In a residential environment this product may cause radio interference in which case the user may be required to take adequate measures.

### Operation in the second environment

In all cases a shielded motor cable must be used, and an EMC filter is required for all drives with a rated input current of less than 100 A.

The drive contains an in-built filter for basic emission control. In some cases feeding the motor cables (U, V and W) once through a ferrite ring can maintain compliance for longer cable lengths.

For longer motor cables, an external filter is required. Where a filter is required, follow the guidelines in Section 4.7.5 *Compliance with generic emission standards*.

Where a filter is not required, follow the guidelines given in section 4.7.3 *General requirements for EMC* on page 43.

The second environment typically includes an industrial low-voltage power supply network which does not supply buildings used for residential purposes. Operating the drive in this environment without an external EMC filter may cause interference to nearby electronic equipment whose sensitivity has not been appreciated. The user must take remedial measures if this situation arises. If the consequences of unexpected disturbances are severe, it is recommended that the guidelines in Section 4.7.5 *Compliance with generic emission standards* be adhered to.

Refer to section 11.1.25 *Electromagnetic compatibility (EMC)* on page 113 for further information on compliance with EMC standards and definitions of environments.

Detailed instructions and EMC information are given in the *EMC Data Sheet* which is available from the supplier of the drive.

### 4.7.5 Compliance with generic emission standards

The following information applies to frame sizes 1 to 4.

Use the recommended filter and shielded motor cable. Observe the layout rules given in Figure 4-17. Ensure the AC supply and ground cables are at least 100 mm from the power module and motor cable.

**Figure 4-17 Supply and ground cable clearance (sizes 1 to 4)**

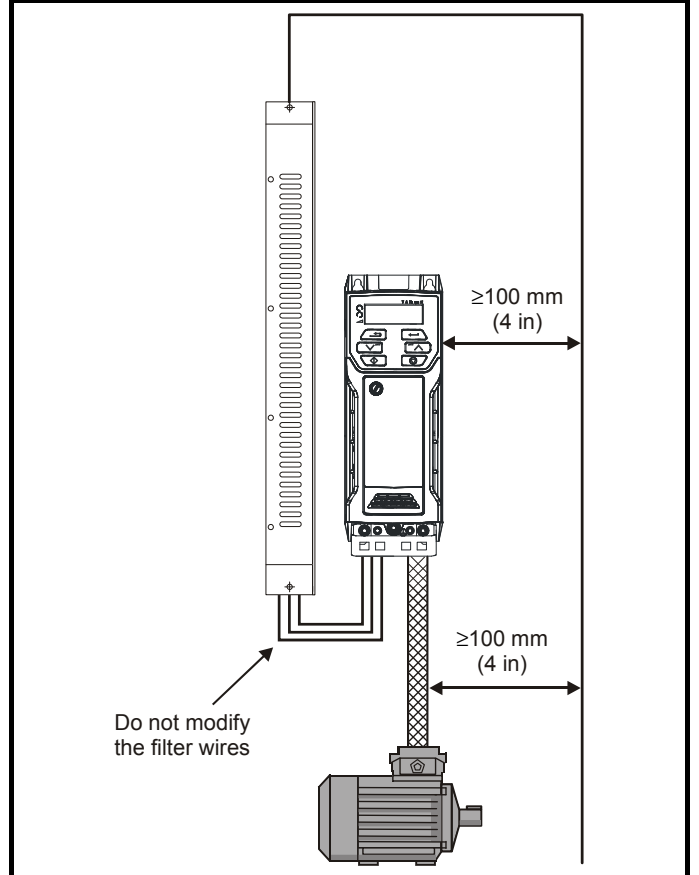

Avoid placing sensitive signal circuits in a zone 300 mm (12 in) in the area immediately surrounding the power module.

**Figure 4-18 Sensitive signal circuit clearance**

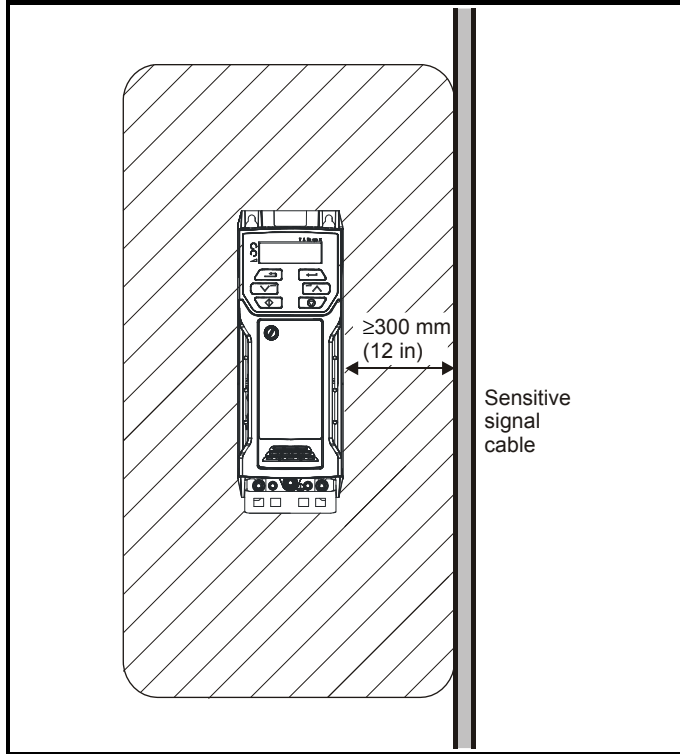

Ensure good EMC grounding.

**Figure 4-19 Grounding the drive, motor cable shield and filter**

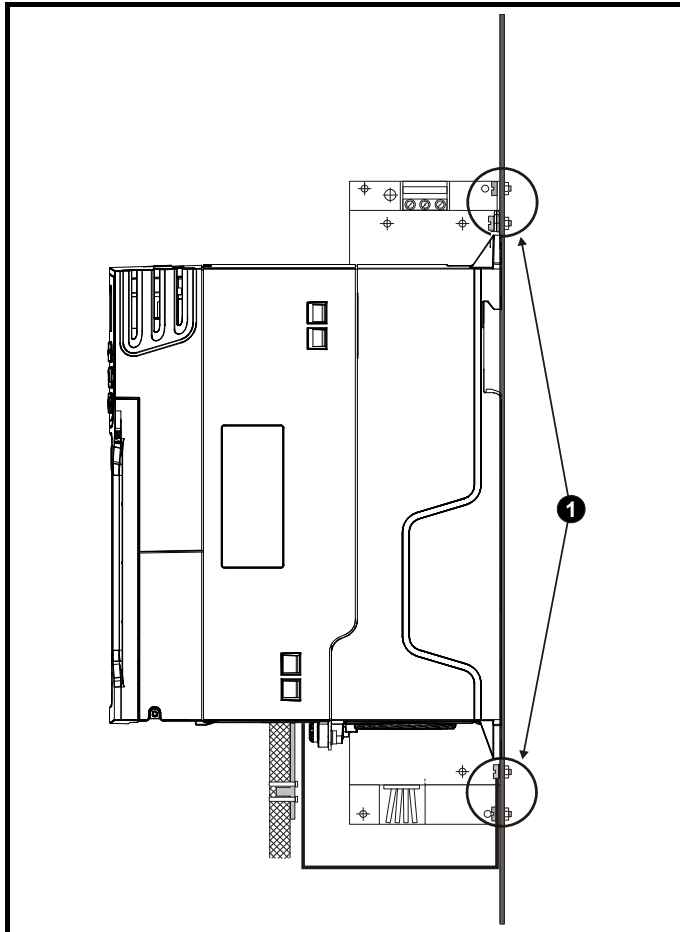

**NOTE**

1 Ensure direct metal contact at the drive and filter mounting points. Any paint must be removed beforehand.

The unbroken motor cable shield (unbroken) electrically connected to and held in place by means of the grounding bracket.

Connect the shield of the motor cable to the ground terminal of the motor frame using a jumper that is as short as possible and not exceeding 50 mm (2 in) long.

A complete 360° termination of the shield to the terminal housing of the motor is beneficial.

From an EMC consideration it is irrelevant whether the motor cable contains an internal (safety) ground core, or if there is a separate external ground conductor, or where grounding is through the shield alone. An internal ground core will carry a high noise current and therefore it must be terminated as close as possible to the shield termination.

**Figure 4-20 Grounding the motor cable shield**

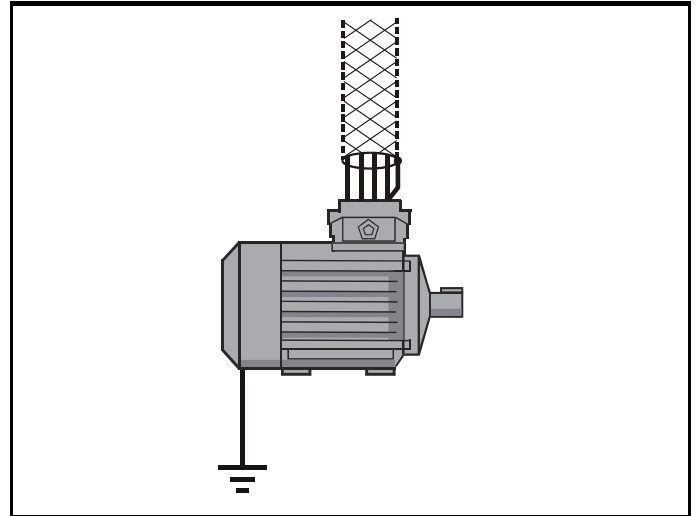

Unshielded wiring to the optional braking resistor(s) may be used provided the wiring runs internally to the enclosure. Ensure a minimum spacing of 300 mm (12 in) from the signal wiring and the AC supply wiring to the external EMC filter. If this condition cannot be met then the wiring must be shielded.

**Figure 4-21 Shielding requirements of optional external braking resistor**

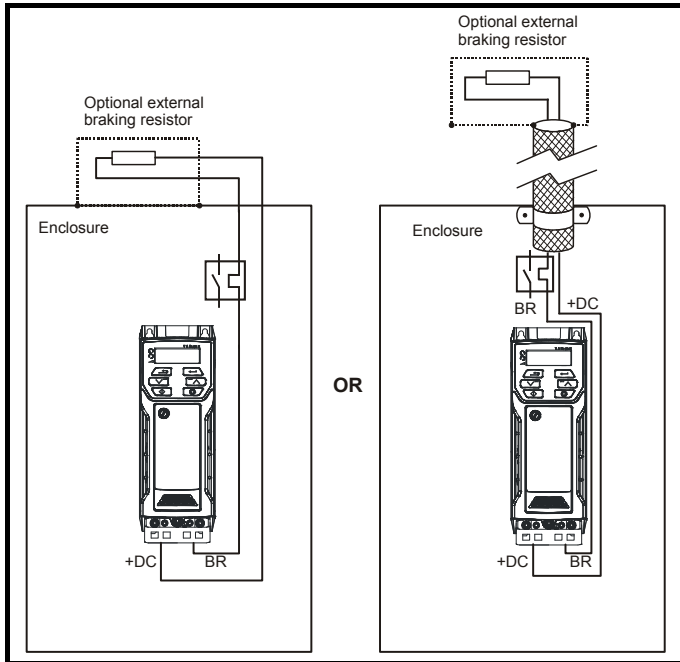

If the control wiring is to leave the enclosure, it must be shielded and the shield(s) clamped to the drive using the grounding bracket as shown in Figure 4-22. Remove the outer insulating cover of the cable to ensure the shield(s) make direct contact with the bracket, but keep the shield(s) intact until as close as possible to the terminals

Alternatively, wiring may be passed through a ferrite ring, part number 3225-1004.

**Figure 4-22 Grounding of signal cable shields using the grounding bracket**

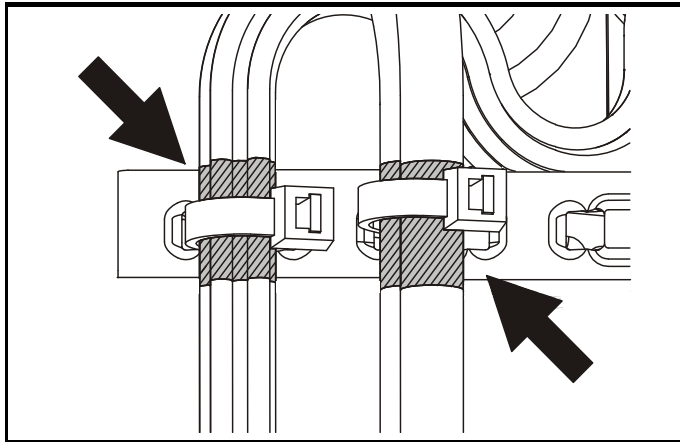

#### 4.7.6 Variations in the EMC wiring Interruptions to the motor cable

The motor cable should ideally be a single length of shielded or armored cable having no interruptions. In some situations it may be necessary to interrupt the cable, as in the following examples:

- Connecting the motor cable to a terminal block in the drive enclosure
- Installing a motor isolator / disconnect switch for safety when work is done on the motor

In these cases the following guidelines should be followed.

##### Terminal block in the enclosure

The motor cable shields should be bonded to the back-plate using uninsulated metal cable-clamps which should be positioned as close as possible to the terminal block. Keep the length of power conductors to a minimum and ensure that all sensitive equipment and circuits are at least 0.3 m (12 in) away from the terminal block.

**Figure 4-23 Connecting the motor cable to a terminal block in the enclosure**

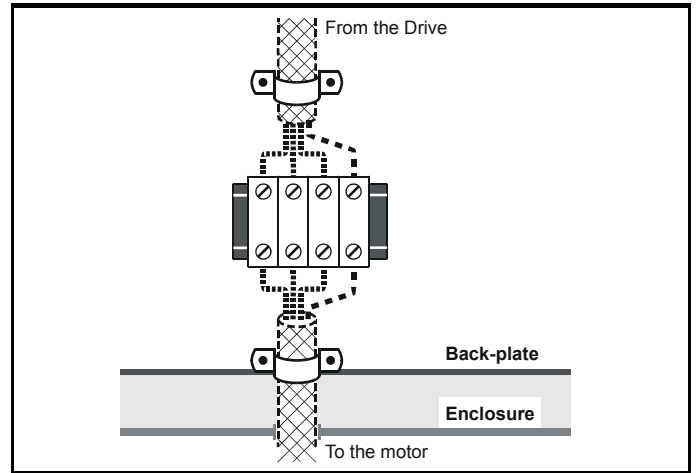

##### Using a motor isolator / disconnect-switch

The motor cable shields should be connected by a very short conductor having a low inductance. The use of a flat metal coupling-bar is recommended; conventional wire is not suitable.

The shields should be bonded directly to the coupling-bar using uninsulated metal cable-clamps. Keep the length of the exposed power conductors to a minimum and ensure that all sensitive equipment and circuits are at least 0.3 m (12 in) away.

The coupling-bar may be grounded to a known low-impedance ground nearby, for example a large metallic structure which is connected closely to the drive ground.

**Figure 4-24 Connecting the motor cable to an isolator / disconnect switch**

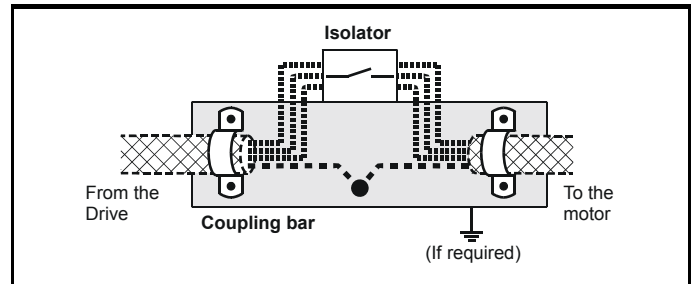

##### Surge immunity of control circuits - long cables and connections outside a building

The input/output ports for the control circuits are designed for general use within machines and small systems without any special precautions.

These circuits meet the requirements of EN 61000-6-2:2005 (1 kV surge) provided the 0 V connection is not grounded.

In applications where they may be exposed to high-energy voltage surges, some special measures may be required to prevent malfunction or damage. Surges may be caused by lightning or severe power faults in association with grounding arrangements which permit high transient voltages between nominally grounded points. This is a particular risk where the circuits extend outside the protection of a building.

As a general rule, if the circuits are to pass outside the building where the drive is located, or if cable runs within a building exceed 30 m, some additional precautions are advisable. One of the following techniques should be used:

- Galvanic isolation, i.e. do not connect the control 0 V terminal to ground. Avoid loops in the control wiring, i.e. ensure every control wire is accompanied by its return (0 V) wire.
- Shielded cable with additional power ground bonding. The cable shield may be connected to ground at both ends, but in addition the ground conductors at both ends of the cable must be bonded together by a power ground cable (equipotential bonding cable) with cross-sectional area of at least 10 mm<sup>2</sup>, or 10 times the area of the signal cable shield, or to suit the electrical safety requirements of the plant. This ensures that fault or surge current passes mainly through the ground cable and not in the signal cable shield. If the building or plant has a well-designed common bonded network this precaution is not necessary.
- Additional over-voltage suppression - for the analog and digital inputs and outputs, a zener diode network or a commercially available surge suppressor may be connected in parallel with the input circuit as shown in Figure 4-25 and Figure 4-26.

If a digital port experiences a severe surge its protective trip may operate (O.Ld1 trip). For continued operation after such an event, the trip can be reset automatically by setting Pr 10.034 to 5.

**Figure 4-25 Surge suppression for digital and unipolar inputs and outputs**

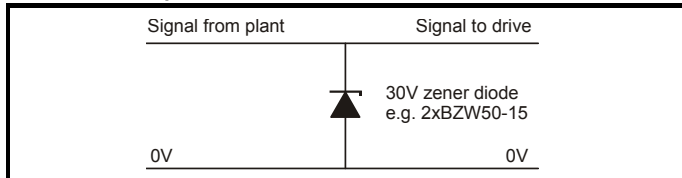

**Figure 4-26 Surge suppression for analog and bipolar inputs and outputs**

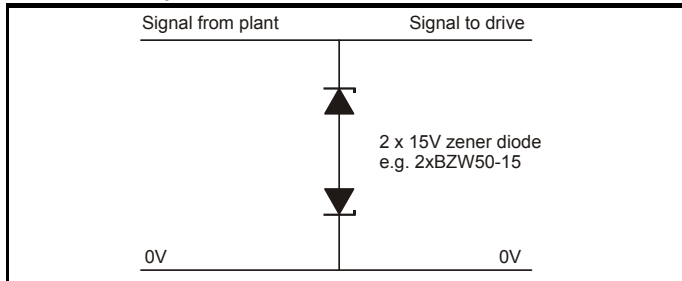

Surge suppression devices are available as rail-mounting modules, e.g. from Phoenix Contact:

- Unipolar TT-UKK5-D/24 DC
- Bipolar TT-UKK5-D/24 AC

These devices are not suitable for encoder signals or fast digital data networks because the capacitance of the diodes adversely affects the signal. Most encoders have galvanic isolation of the signal circuit from the motor frame, in which case no precautions are required. For data networks, follow the specific recommendations for the particular network.

## 4.8 Control connections

### 4.8.1 General

**Table 4-15 The control connections consist of:**

Function	Qty	Control parameters available	Terminal number
Single ended analog input	1	Mode, offset, invert, scaling, destination	2
Digital input	3	Destination, invert	11, 12, 13
Digital input / output	1	Input / output mode select, destination / source, invert	10
Relay	1	Source, invert	41, 42
Drive enable	1		11
+10 V User output	1		4
+24 V User output	1		9
0V common	1		1

**Key:**

Destination parameter:	Indicates the parameter which is being controlled by the terminal / function
Source parameter:	Indicates the parameter being output by the terminal
Mode parameter:	Analog - indicates the mode of operation of the terminal, i.e. voltage 0-10 V, current 4-20 mA etc. Digital - indicates the mode of operation of the terminal, (the Drive Enable terminal is fixed in positive logic).

All analog terminal functions can be programmed in menu 7.

All digital terminal functions (including the relay) can be programmed in menu 8.

**WARNING** The control circuits are isolated from the power circuits in the drive by basic insulation (single insulation) only. The installer must ensure that the external control circuits are insulated from human contact by at least one layer of insulation (supplementary insulation) rated for use at the AC supply voltage.

**WARNING** If the control circuits are to be connected to other circuits classified as Safety Extra Low Voltage (SELV) (e.g. to a personal computer), an additional isolating barrier must be included in order to maintain the SELV classification.

**CAUTION** If any of the digital inputs (including the drive enable input) are connected in parallel with an inductive load (i.e. contactor or motor brake) then suitable suppression (i.e. diode or varistor) should be used on the coil of the load. If no suppression is used then over voltage spikes can cause damage to the digital inputs and outputs on the drive.

**NOTE**

Any signal cables which are carried inside the motor cable (i.e. motor thermistor, motor brake) will pick up large pulse currents via the cable capacitance. The shield of these signal cables must be connected to ground close to the point of exit of the motor cable, to avoid this noise current spreading through the control system.

Figure 4-27 Default terminal functions

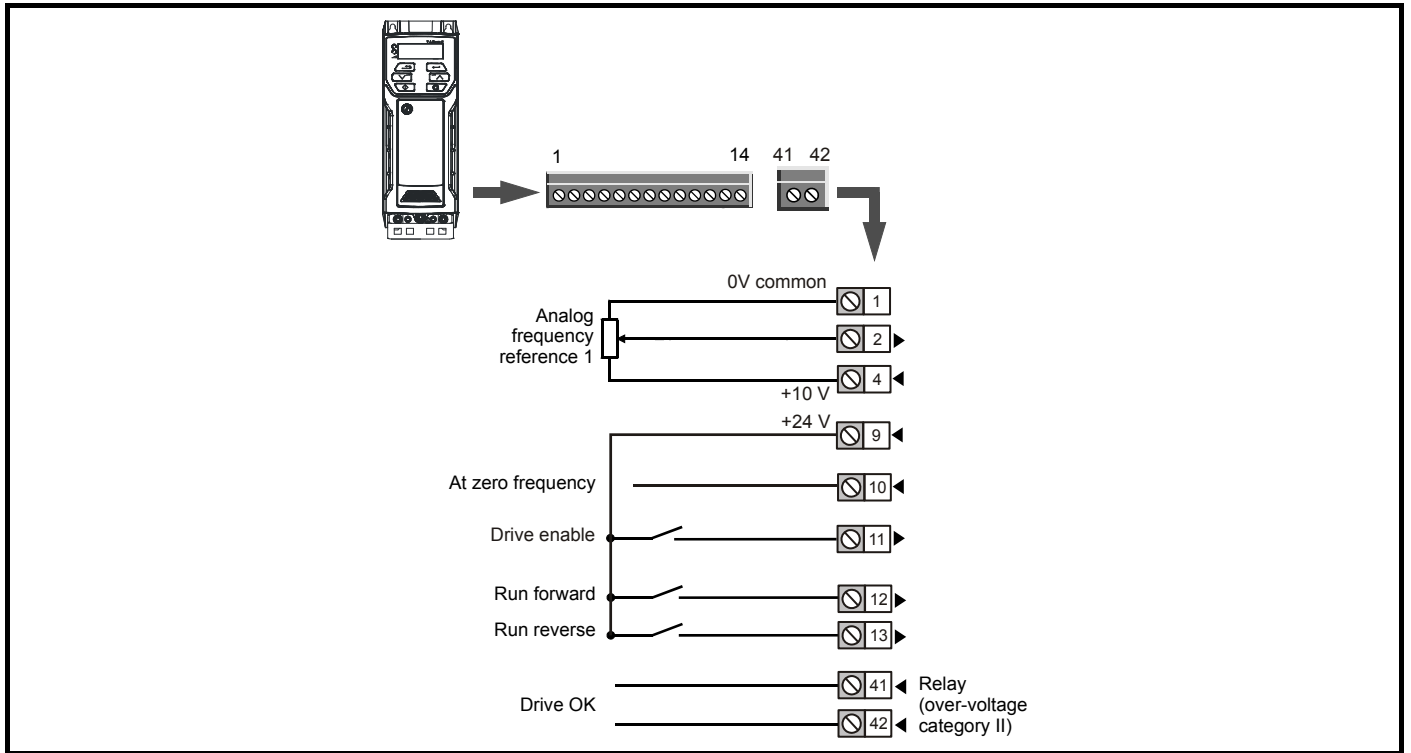

#### 4.8.2 Control terminal specification

<b>1</b>	<b>0V common</b>
<b>Function</b>	<b>Common connection for all external devices</b>

<b>2</b>	<b>Analog input 1</b>
<b>Default function</b>	<b>Frequency reference</b>
Type of input	Unipolar single-ended analog voltage or unipolar current
Mode controlled by...	Pr <b>07.007</b>
<b>Operating in voltage mode (default)</b>	
Full scale voltage range	0 V to +10 V $\pm 3\%$
Maximum offset	$\pm 30$ mV
Absolute maximum voltage range	-18 V to +30 V relative to 0 V
Input resistance	100 k $\Omega$
<b>Operating in current mode</b>	
Current ranges	0 to 20 mA $\pm 5\%$ , 20 to 0 mA $\pm 5\%$ , 4 to 20 mA $\pm 5\%$ , 20 to 4 mA $\pm 5\%$
Maximum offset	250 $\mu$ A
Absolute maximum voltage (reverse bias)	-18 V to +30 V relative to 0 V
Absolute maximum current	25 mA
Equivalent input resistance	165 $\Omega$
<b>Common to all modes</b>	
Resolution	11 bits
Sample / update	5 ms

<b>4</b>	<b>+10 V user output</b>
<b>Default function</b>	<b>Supply for external analog devices</b>
Nominal voltage	10.2 V
Voltage tolerance	$\pm 3\%$
Maximum output current	5 mA



<b>9</b>	<b>+24 V user output</b>
<b>Default function</b>	<b>Supply for external digital devices</b>
Voltage tolerance	±20 %
Maximum output current	100 mA
Protection	Current limit and trip

<b>10</b>	<b>Digital I/O 1</b>
<b>Default function</b>	<b>AT ZERO FREQUENCY output</b>
Type	Positive logic digital input, positive logic voltage source output. PWM or frequency output modes can be selected.
Input / output mode controlled by ...	Pr <b>08.031</b>
<b>Operating as in input</b>	
Absolute maximum applied voltage range	-8 V to +30 V relative to 0 V
Impedance	6.8 kΩ
Input threshold	10 V ±0.8 V from IEC 61131-2
<b>Operating as an output</b>	
Nominal maximum output current	50 mA
Maximum output current	100 mA (total including +24 Vout)
<b>Common to all modes</b>	
Voltage range	0 V to +24 V
Sample / update period	2 ms when routed to destinations Pr <b>06.035</b> or Pr <b>06.036</b> , otherwise 6 ms

<b>11</b>	<b>Digital Input 2</b>
<b>12</b>	<b>Digital Input 3</b>
<b>13</b>	<b>Digital Input 4</b>
<b>Terminal 11 default function</b>	<b>DRIVE ENABLE input</b>
<b>Terminal 12 default function</b>	<b>RUN FORWARD input</b>
<b>Terminal 13 default function</b>	<b>RUN REVERSE input</b>
Type	Positive logic only digital inputs
Voltage range	0 V to +24 V
Absolute maximum applied voltage range	-18 V to +30 V relative to 0 V
Impedance	6.8 kΩ
Input threshold	10 V ±0.8 V from IEC 61131-2
Sample / update period	2 ms when routed to destinations Pr 06.035 or Pr 06.036, otherwise 6 ms.

<b>41</b>	<b>Relay contacts</b>
<b>42</b>	
<b>Default function</b>	<b>Drive OK indicator</b>
Contact voltage rating	240 Vac, Installation over-voltage category II
Contact maximum current rating	2 A AC 240 V 4 A DC 30 V resistive load 0.5 A DC 30 V inductive load (L/R = 40 ms)
Contact minimum recommended rating	12 V 100 mA
Contact type	Normally open
Default contact condition	Closed when power applied and drive OK
Update period	4 ms



To prevent the risk of a fire hazard in the event of a fault, a fuse or other over-current protection must be installed in the relay circuit.

## 5 Getting started

This chapter introduces the user interfaces, menu structure and security levels of the drive.

### 5.1 Understanding the display

#### 5.1.1 Keypad

The keypad display consists of a 6 digit LED display. The display shows the drive status or the menu and parameter number currently being edited.

The mm.ppp signifies the menu parameter number of the drive's menus and parameter.

The display also includes LED indicators showing units and status as shown in Figure 5-1.

When the drive is powered up, the display will show the power up parameter defined by *Parameter Displayed At Power-Up* (11.022).

**Figure 5-1 Unidrive M100 keypad detail**

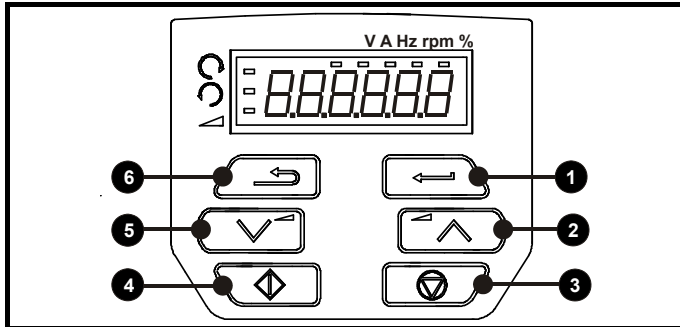

**Table 5-1 Key to Figure 5-1**

- |                            |                  |
|----------------------------|------------------|
| 1: Enter button            | 4: Start button  |
| 2: Up button               | 5: Down button   |
| 3: Stop/Reset button (red) | 6: Escape button |

**Figure 5-2 Unidrive M101 keypad detail**

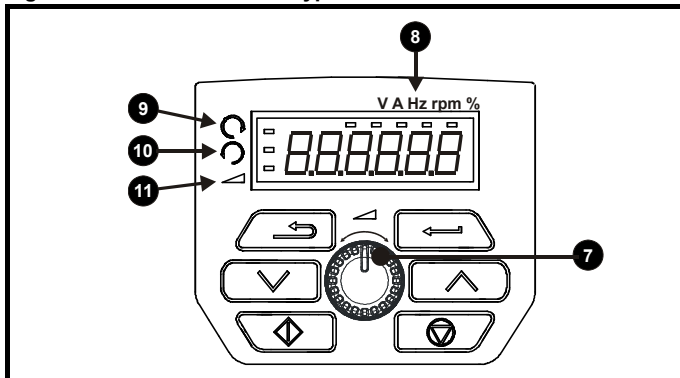

**Table 5-2 Key to Figure 5-2**

- |                                  |                                |
|----------------------------------|--------------------------------|
| 7: Speed reference potentiometer | 10: Run reverse indicator      |
| 8: Unit indicators               | 11: Keypad reference indicator |
| 9: Run forward indicator         |                                |

#### NOTE

The red stop button  is also used to reset the drive.

On the Unidrive M101, the speed reference potentiometer is used to adjust the keypad reference.

The parameter value is correctly displayed on the keypad display as shown in Table 5-3 below.

**Table 5-3 Keypad display formats**

Display formats	Value
Standard	100.99
Date	31.12.11 or 12.31.11
Time	12.34.56
Character	ABCDEF
Binary	5
Version number	01.23.45

### 5.2 Keypad operation

#### 5.2.1 Control buttons

The keypad consists of:

- Up and down button - Used to navigate the parameter structure and change parameter values.
- Enter button - Used to toggle between parameter edit and view mode.
- Escape button - Used to exit from parameter edit or view mode. In parameter edit mode, if parameter values are edited and the escape button pressed, the parameter value will be restored to the value it had on entry to edit mode.
- Start button - Used to provide a 'Run' command if keypad mode is selected.
- Stop / Reset button - Used to reset the drive. In keypad mode can be used for 'Stop'.

Figure 5-3 Display modes

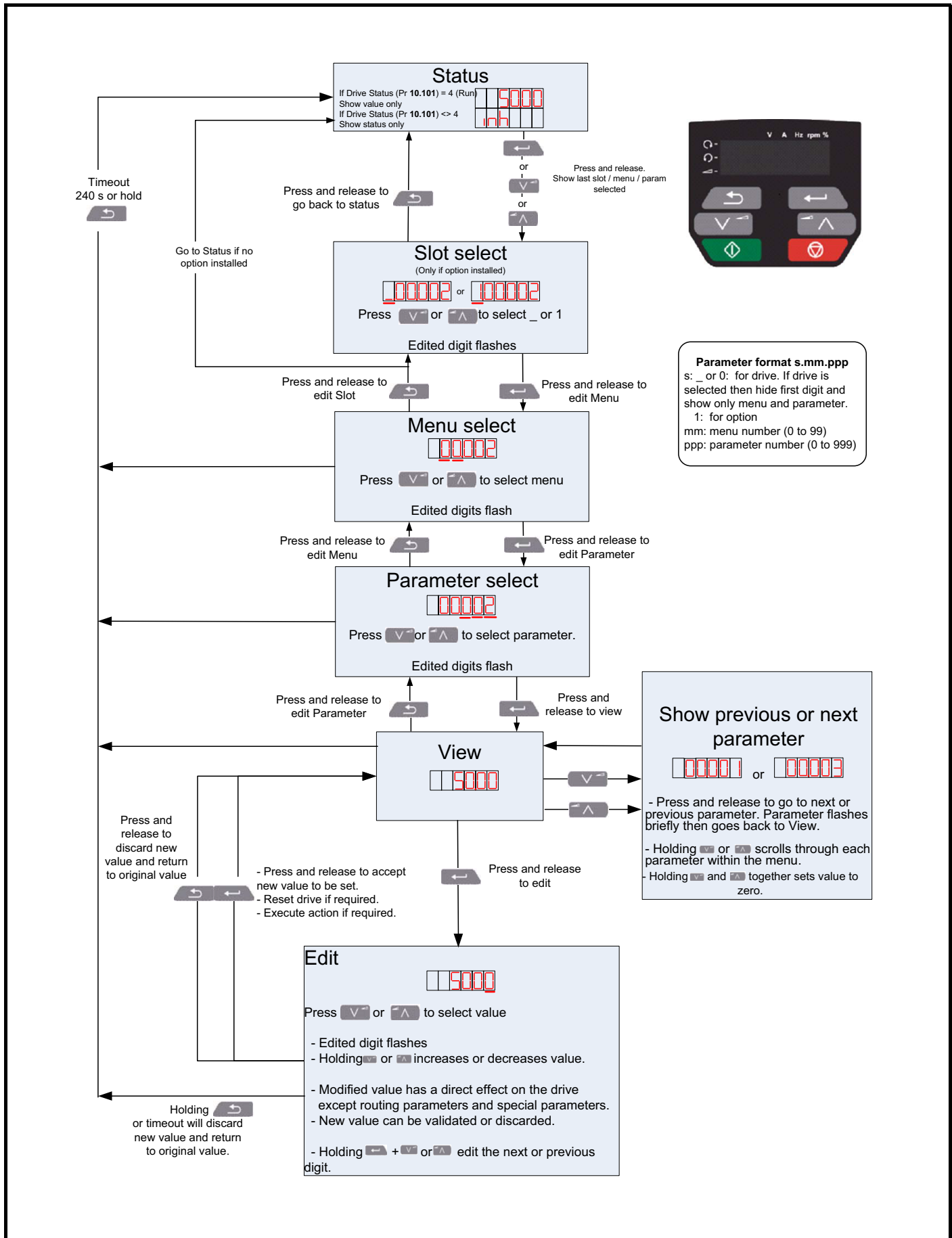

**NOTE**

The up and down buttons can only be used to move between menus if Pr **00.010** has been set to show 'ALL'. Refer to section 5.8 *Parameter access level and security* on page 54.

**Figure 5-4 Mode examples**

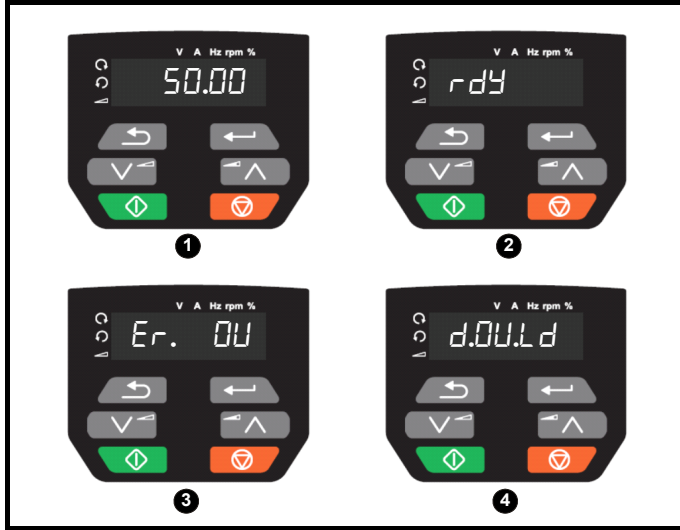

- 1 Parameter view mode: Read write or Read only
- 2 Status mode: Drive OK status  
If the drive is ok and the parameters are not being edited or viewed, the display will show one of the following:  
inh', 'rdy' or status mode parameter value.
- 3 Status mode: Trip status  
When the drive is in trip condition, the display will indicate that the drive has tripped and the display will show the trip code. For further information regarding trip codes, refer to section 12.4 *Trips, Sub-trip numbers* on page 117.
- 4 Status mode: Alarm status  
During an 'alarm' condition the display flashes between the drive status parameter value and the alarm.

Do not change parameter values without careful consideration; incorrect values may cause damage or a safety hazard.

**WARNING**

**NOTE**

When changing the values of parameters, make a note of the new values in case they need to be entered again.

**NOTE**

For new parameter values to apply after the line power supply to the drive is interrupted, new values must be saved. Refer to section 5.6 *Saving parameters* on page 53.

### 5.3 Menu structure

The drive parameter structure consists of menus and parameters. The drive initially powers up so that only Menu 0 can be viewed. The up and down arrow buttons are used to navigate between parameters and once Pr **00.010** has been set to 'All' the up and down buttons are used to navigate between menus.

For further information refer to section 5.8 *Parameter access level and security* on page 54.

The menus and parameters rollover in both directions i.e. if the last parameter is displayed, a further press will cause the display to rollover and show the first parameter.

When changing between menus, the drive remembers which parameter was last viewed in a particular menu and thus displays that parameter.

### 5.4 Menu 0

Menu 0 is used to bring together various commonly used parameters for basic easy set up of the drive. The parameters displayed in Menu 0 can be configured in Menu 22.

Appropriate parameters are copied from the advanced menus into Menu 0 and thus exist in both locations.

For further information, refer to Chapter 6 *Basic parameters* on page 55.

**Figure 5-5 Menu 0 copying**

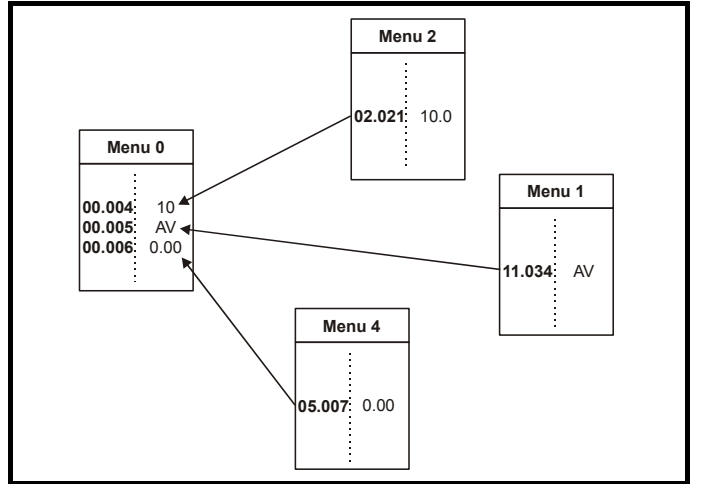

## 5.5 Advanced menus

The advanced menus consist of groups or parameters appropriate to a specific function or feature of the drive. Menus 0 to 22 can be viewed on the Keypad.

**Table 5-4 Advanced menu descriptions**

Menu	Description
0	Commonly used basic set up parameters for quick / easy programming
1	Frequency reference
2	Ramps
3	Frequency control
4	Torque and current control
5	Motor control
6	Sequencer and clock
7	Analog I/O
8	Digital I/O
10	Status and trips
11	Drive set-up and identification
22	Menu 0 set-up

### 5.5.1 Display messages

The following tables indicate the various possible mnemonics which can be displayed by the drive and their meaning.

**Table 5-5 Status indications**

String	Description	Drive output stage
inh	The drive is inhibited and cannot be run. The Drive Enable signal is not applied to the drive enable terminal or Pr <b>06.015</b> is set to 0. The other conditions that can prevent the drive from enabling are shown as bits in <i>Enable Conditions</i> (06.010)	Disabled
rdy	The drive is ready to run. The drive enable is active, but the drive inverter is not active because the final drive run is not active	Disabled
StoP	The drive is stopped / holding zero speed.	Enabled
S.Loss	Supply loss condition has been detected	Enabled
dc inj	The drive is applying dc injection braking	Enabled
Er	The drive has tripped and no longer controlling the motor. The trip code appears on the display.	Disabled
UV	The drive is in the under voltage state either in low voltage or high voltage mode.	Disabled

### 5.5.2 Alarm indications

An alarm is an indication given on the display by alternating the alarm string with the drive status string on the display. Alarms strings are not displayed when a parameter is being edited.

**Table 5-6 Alarm indications**

Alarm string	Description
br.res	Brake resistor overload. <i>Braking Resistor Thermal Accumulator</i> (10.039) in the drive has reached 75.0 % of the value at which the drive will trip.
OV.Ld	<i>Motor Protection Accumulator</i> (04.019) in the drive has reached 75.0 % of the value at which the drive will trip and the load on the drive is >100 %.
d.OV.Ld	Drive over temperature. <i>Percentage Of Drive Thermal Trip Level</i> (07.036) in the drive is greater than 90 %.
tuning	The autotune procedure has been initialized and an autotune in progress.
LS	Limit switch active. Indicates that a limit switch is active and that is causing the motor to be stopped.
Lo.AC	Low voltage mode. See <i>Low AC Alarm</i> (10.107).
I.AC.Lt	Current limit active. See <i>Current Limit Active</i> (10.009).

## 5.6 Saving parameters

When changing a parameter in Menu 0, the new value is saved when pressing the Enter button  to return to parameter view mode from parameter edit mode.

If parameters have been changed in the advanced menus, then the change will not be saved automatically. A save function must be carried out.

### Procedure

1. Select 'Save\*' in Pr **mm.000** (alternatively enter a value of 1000\* in Pr **mm.000**)

- Press the red  reset button

\* If the drive is in the under voltage state (i.e. when the AI-Backup adaptor terminals are being supplied from a +24 V DC supply) a value of 1001 must be entered into Pr **mm.000** to perform a save function.

## 5.7 Restoring parameter defaults

Restoring parameter defaults by this method saves the default values in the drives memory. *User security status* (00.010) and *User security code* (00.025) are not affected by this procedure).

### Procedure

1. Ensure the drive is not enabled, i.e. terminal 11 is open or Pr **06.015** is OFF (0)
2. Select 'Def.50' or 'Def.60' in Pr **mm.000**. (alternatively, enter 1233 (50 Hz settings) or 1244 (60 Hz settings) in Pr **mm.000**).

- Press the red  reset button

## 5.8 Parameter access level and security

The parameter access level determines whether the user has access to Menu 0 only or to all the advanced menus (Menus 1 to 22) in addition to Menu 0.

The User Security determines whether the access to the user is read only or read write.

Both the User Security and Parameter Access Level can operate independently of each other as shown in table Table 5-7.

**Table 5-7 Parameter access level and security**

User security status (11.044)	Access level	User security	Menu 0 status	Advanced menu status
0	Menu 0	Open	RW	Not visible
		Closed	RO	Not visible
1	All Menus	Open	RW	RW
		Closed	RO	RO
2	Read-only Menu 0	Open	RO	Not visible
		Closed	RO	Not visible
3	Read-only	Open	RO	RO
		Closed	RO	RO
4	Status only	Open	Not visible	Not visible
		Closed	Not visible	Not visible
5	No access	Open	Not visible	Not visible
		Closed	Not visible	Not visible

The default settings of the drive are Parameter Access Level Menu 0 and user Security Open i.e. read / write access to Menu 0 with the advanced menus not visible.

### 5.8.1 User Security Level / Access Level

The drive provides a number of different levels of security that can be set by the user via *User Security Status* (11.044); these are shown in the table below.

User Security Status (Pr 11.044)	Description
LEVEL.0 (0)	All writable parameters are available to be edited but only parameters in Menu 0 are visible
ALL (1)	All parameters are visible and all writable parameters are available to be edited
r.only.0 (2)	Access is limited to Menu 0 parameters only. All parameters are read-only
r.only.A (3)	All parameters are read-only however all menus and parameters are visible
Status (4)	The keypad remains in status mode and no parameters can be viewed or edited
no.acc (5)	The keypad remains in status mode and no parameters can be viewed or edited.

### 5.8.2 Changing the User Security Level /Access Level

The security level is determined by the setting of Pr **00.010** or Pr **11.044**. The Security Level can be changed through the keypad even if the User Security Code has been set.



#### 5.8.3 User Security Code

The User Security Code, when set, prevents write access to any of the parameters in any menu.

##### Setting User Security Code

Enter a value between 1 and 9999 in Pr **00.025** and press the  button; the security code has now been set to this value. In order to activate the security, the Security level must be set to desired level in Pr **00.010**. When the drive is reset, the security code will have been activated and the drive returns to Menu 0. The value of Pr **00.025** will return to 0 in order to hide the security code.

##### Unlocking User Security Code

Select a parameter that need to be edited and press the  button, the display will now show 'Co'. Use the arrow buttons to set the security code and press the  button. With the correct security code entered, the display will revert to the parameter selected in edit mode.

If an incorrect security code is entered, the following message 'Co.Err' is displayed, and the display will revert to parameter view mode.

##### Disabling User Security

Unlock the previously set security code as detailed above. Set Pr **00.025** to 0 and press the  button. The User Security has now been disabled, and will not have to be unlocked each time the drive is powered up to allow read / write access to the parameters.

## 5.9 Displaying parameters with non-default values only

By selecting 'diff.d' in Pr **mm.000** (Alternatively, enter 12000 in Pr **mm.000**), the only parameters that will be visible to the user will be those containing a non-default value. This function does not require a drive reset to become active. In order to deactivate this function, return to Pr **mm.000** and select 'none' (alternatively enter a value of 0). Please note that this function can be affected by the access level enabled, refer to section 5.8 *Parameter access level and security* on page 54 for further information regarding access level.

## 5.10 Displaying destination parameters only

By selecting 'dest' in Pr **mm.000** (Alternatively enter 12001 in Pr **mm.000**), the only parameters that will be visible to the user will be destination parameters. This function does not require a drive reset to become active. In order to deactivate this function, return to Pr **mm.000** and select 'none' (alternatively enter a value of 0).

Please note that this function can be affected by the access level enabled, refer to section 5.8 *Parameter access level and security* on page 54 for further information regarding access level.

## 6 Basic parameters

Menu 0 is used to bring together various commonly used parameters for basic easy set up of the drive. All the parameters in Menu 0 appear in other menus in the drive (denoted by {...}). Menus 22 can be used to configure the parameters in Menu 0.

### 6.1 Menu 0: Basic parameters

Parameter	Range (⇅)		Default (⇒)		Type						
	OL		OL								
00.001	Minimum Reference Clamp	±VM_NEGATIVE_REF_CLAMP 1 Hz		0.00 Hz		RW	Num				US
00.002	Maximum Reference Clamp	±VM_POSITIVE_REF_CLAMP Hz		50 Hz default: 50.00 Hz 60 Hz default: 60.00 Hz		RW	Num				US
00.003	Acceleration Rate 1	±VM_ACCEL_RATE s		5.0 s		RW	Num				US
00.004	Deceleration Rate 1	±VM_ACCEL_RATE s		10.0 s		RW	Num				US
00.005	Drive Configuration	AV (0), AI (1), AV.Pr (2), AI.Pr (3), Preset (4), Pad (5), Pad.Ref (6), torque (8)		AV (0)		RW	Txt			PT	US
00.006	Motor Rated Current	±VM_RATED_CURRENT A		Maximum Heavy Duty Rating (11.032) A		RW	Num		RA		US
00.007	Motor Rated Speed	0.0 to 80000.0 rpm		50 Hz default: 1500.0 rpm 60 Hz default: 1800.0 rpm		RW	Num				US
00.008	Motor Rated Voltage	±VM_AC_VOLTAGE_SET V		110 V drive: 230 V 200 V drive: 230 V 400 V drive 50 Hz: 400 V 400 V drive 60 Hz: 460 V 575 V drive: 575 V 690 V drive: 690 V		RW	Num		RA		US
00.009	Motor Rated Power Factor	0.00 to 1.00		0.85		RW	Num		RA		US
00.010	User Security Status	LEVEL.0 (0), ALL (1), r.only.0 (2), r.only.A (3), Status (4), no.acc(5)		LEVEL.0 (0)		RW	Num	ND	NC	PT	
00.015	Jog Reference	0.00 to 300.00 Hz		1.50 Hz		RW	Num				US
00.016	Analog Input 1 Mode	4-20.S (-6), 20-4.S (-5), 4-20.L (-4), 20-4.L (-3), 4-20.H (-2), 20-4.H (-1), 0-20 (0), 20-0 (1), 4-20.tr (2), 20-4.tr (3), 4-20 (4), 20-4 (5), Volt (6)		Volt (6)		RW	Txt				US
00.017	Bipolar Reference Enable	Off (0) or On (1)		Off (0)		RW	Bit				US
00.018	Preset Reference 1	±VM_SPEED_FREQ_REF Hz		0.00 Hz		RW	Num				US
00.025	User Security Code	0 to 9999		0		RW	Num	ND	NC	PT	US
00.027	Power-up Keypad Control Mode Reference	Reset (0), Last (1), Preset (2)		Reset (0)		RW	Txt				US
00.028	Ramp Mode Select	Fast (0), Std (1), Std.bst (2), Fst.bst (3)		Std (1)		RW	Txt				US
00.030	Parameter Cloning	None (0), rAd (1), Prog (2), Auto (3), boot (4)		None (0)		RW	Txt		NC		US
00.031	Stop Mode	Coast (0), rp (1), rp.dc I (2), dc I (3), td.dc I (4), dis (5), No.rp (6)		rp (1)		RW	Txt				US
00.032	Dynamic V to F Select	0 to 1		0		RW	Num				US
00.033	Catch A Spinning Motor	dis (0), Enable (1), Fr.Only (2), Rv.Only (3)		dis (0)		RW	Txt				US
00.035	Digital Output 1 Control	0 to 21		0		RW					US
00.037	Maximum Switching Frequency	0.667 (0), 1 (1), 2 (2), 3 (3), 4 (4), 6 (5), 8 (6), 12 (7), 16 (8) kHz		3 (3) kHz		RW	Txt				US
00.038	Autotune	0 to 2		0		RW	Num		NC		US
00.039	Motor Rated Frequency	0.0 to VM_SPEED_FREQ_REF_UNIPOLAR Hz		50 Hz: 50.00 Hz 60 Hz: 60.00 Hz		RW	Num		RA		US
00.040	Number of Motor Poles	Auto (0) to 32 (16)		Auto 0		RW	Num				US
00.041	Control Mode	Ur.S (0), Ur (1), Fd (2), Ur.Auto (3), Ur.I (4), SrE (5)		Ur.I (4)		RW	Txt				US
00.042	Low Frequency Voltage Boost	0.0 to 25.0 %		3.0 %		RW	Num				US
00.069	Spin Start Boost	0.0 to 10.0		1.0		RW					US
00.076	Action on Trip Detection	0 to 31		0		RW					US
00.077	Maximum Heavy Duty Current Rating	0.00 to 9999.99 A				RO	Num	ND	NC	PT	
00.078	Software Version	0 to 999999				RO		ND	NC	PT	
00.079	User Drive Mode	OPEn.LP (1)		OPEn.LP (1)		RW	Txt	ND	NC	PT	US
00.080	User Security Status	LEVEL.0 (0), ALL (1), r.only.0 (2), r.only.A (3), Status (4), no.acc(5)		LEVEL.O. (0)		RW	Txt	ND		PT	

RW	Read / Write	RO	Read only	Num	Number parameter	Bit	Bit parameter	Txt	Text string	Bin	Binary parameter	FI	Filtered
ND	No default value	NC	Not copied	PT	Protected parameter	RA	Rating dependent	US	User save	PS	Power-down save	DE	Destination
IP	IP address	Mac	Mac address	Date	Date parameter	Time	Time parameter						

Figure 6-1 Menu 0 logic diagram

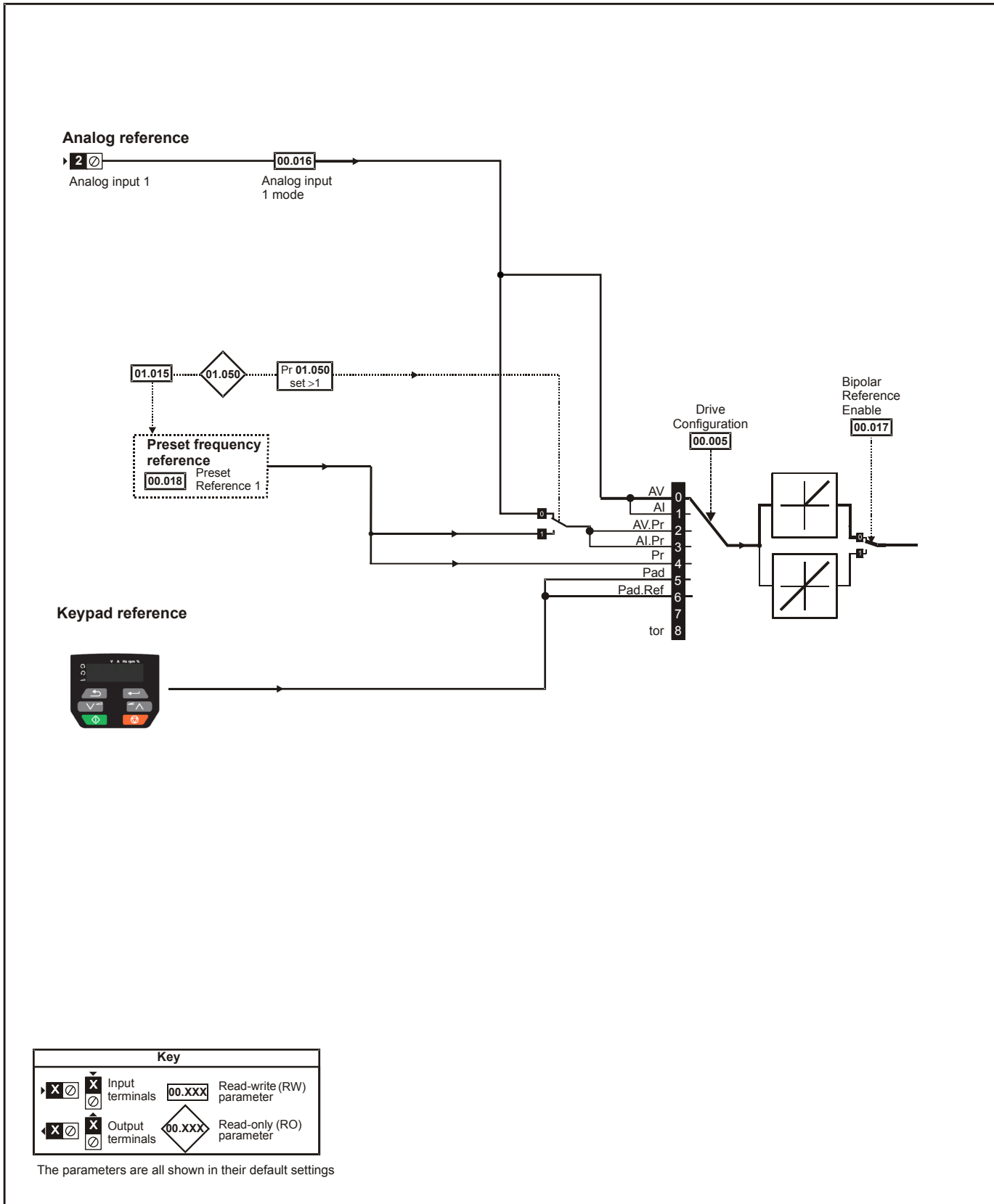



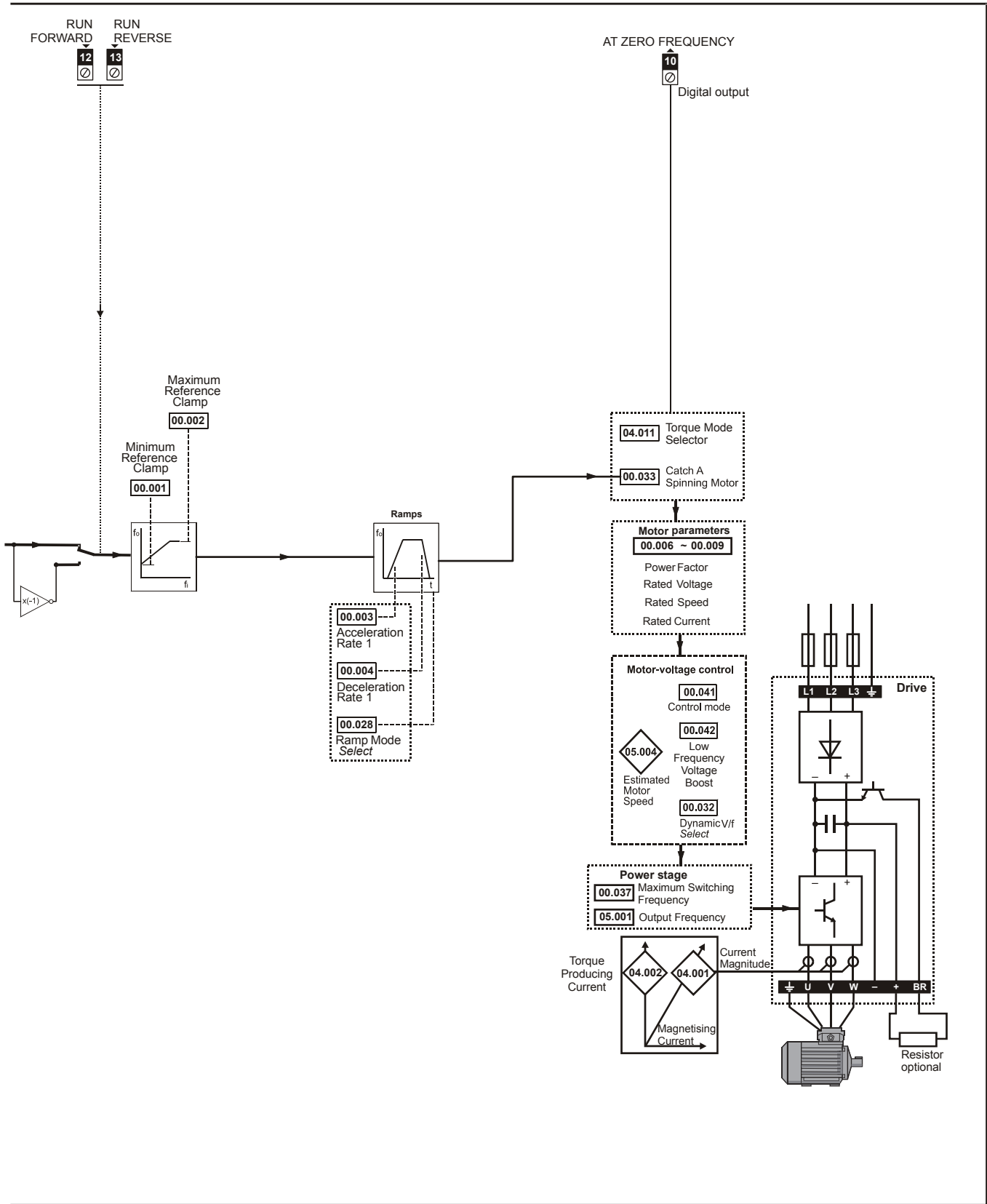

## 6.2 Parameter descriptions

### 6.2.1 Pr mm.000

Pr **mm.000** is available in all menus, commonly used functions are provided as text strings in Pr **mm.000** shown in Table 6-1. The functions in Table 6-1 can also be selected by entering the appropriate numeric values (as shown in Table 6-2) in Pr **mm.000**. For example, enter 7001 in Pr **mm.000** to store drive parameters on an NV media card.

**Table 6-1 Commonly used functions in xx.000**

Value	Equivalent value	String	Action
0	0	None	No action
1000	1	SAVE	Save drive parameters to non-volatile memory
6001	2	read1	Load the data from file 1 on a non-volatile media card into the drive provided it is a parameter file
4001	3	SAVE1	Store the drive parameters in file 1 on a non-volatile media card
6002	4	read2	Load the data from file 2 on a non-volatile media card into the drive provided it is a parameter file
4002	5	SAVE2	Store the drive parameters in file 2 on a non-volatile media card
6003	6	read3	Load the data from file 3 on a non-volatile media card into the drive provided it is a parameter file
4003	7	SAVE3	Store the drive parameters in file 3 on a non-volatile media card
12000	8	diff.d	Only display parameters that are different from their default value
12001	9	dest	Only display parameters that are used to set-up destinations
1233	10	def.50	Load 50 Hz defaults
1244	11	def.60	Load 60 Hz defaults

**Table 6-2 Functions in Pr mm.000**

Value	Action
1000	Save parameters when <i>Under Voltage Active</i> (Pr <b>10.016</b> ) is not active.
1001	Save parameter under all conditions
1233	Load standard (50 Hz) defaults
1244	Load US (60 Hz) defaults
1299	Reset {St.HF} trip.
2001*	Create a boot file on a non-volatile media card based on the present drive parameters
4yyy*	NV media card: Transfer the drive parameters to parameter file yyy
6yyy*	NV media card: Load the drive parameters from parameter file yyy
7yyy*	NV media card: Erase file yyy
8yyy*	NV Media card: Compare the data in the drive with file yyy
9555*	NV media card: Clear the warning suppression flag
9666*	NV media card: Set the warning suppression flag
9777*	NV media card: Clear the read-only flag
9888*	NV media card: Set the read-only flag
12000**	Only display parameters that are different from their default value. This action does not require a drive reset.
12001**	Only display parameters that are used to set-up destinations (i.e. DE format bit is 1). This action does not require a drive reset.
40yyy	Backup all drive data (parameter differences from defaults), including the drive name; the store will occur to the </fs/MCDF/driveyyy/> folder; if it does not exist, it will be created. Since the name is stored, this is a backup, rather than a clone. The command code will be cleared when all drive data has been saved.
60yyy	Load all drive data (parameter differences from defaults); the load will come from the </fs/MCDF/driveyyy/> folder. The command code will not be cleared until the drive has been loaded.

\* See Chapter 9 *NV Media Card Operation* on page 78 for more information on these functions.

\*\* These functions do not require a drive reset to become active.

All other functions require a drive reset to initiate the function. To allow easy access to some commonly used functions, refer to the table overleaf. Equivalent values and strings are also provided in the table above.

# 7 Running the motor

This chapter takes the new user through all the essential steps to running a motor for the first time, in each of the possible operating modes.

For information on tuning the drive for the best performance, see *Chapter 8 Optimization on page 62*.



Ensure that no damage or safety hazard could arise from the motor starting unexpectedly.



The values of the motor parameters affect the protection of the motor.  
The default values in the drive should not be relied upon.  
It is essential that the correct value is entered in Pr **00.006 Motor Rated Current**. This affects the thermal protection of the motor.



If the drive is started using the keypad it will run to the speed defined by the keypad reference (Pr **01.017**). This may not be acceptable depending on the application. The user must check in Pr **01.017** and ensure that the keypad reference has been set to 0.



If the intended maximum speed affects the safety of the machinery, additional independent over-speed protection must be used.

## 7.1 Quick start connections

### 7.1.1 Basic requirements

This section shows the basic connections which must be made for the drive to run in the required mode. For minimal parameter settings to run in each mode please see the relevant part of section 7.2 *Quick start commissioning / start-up* on page 61.

**Table 7-1 Minimum control connection requirements for each control mode**

Drive control method	Requirements
Terminal mode	Drive enable Speed / Torque reference Run forward / Run reverse
Keypad mode	Drive enable

**Table 7-2 Minimum control connection requirements for each mode of operation**

Operating mode	Requirements
Open loop mode	Induction motor

**Figure 7-1 Minimum connections to get the motor running in any operating mode**

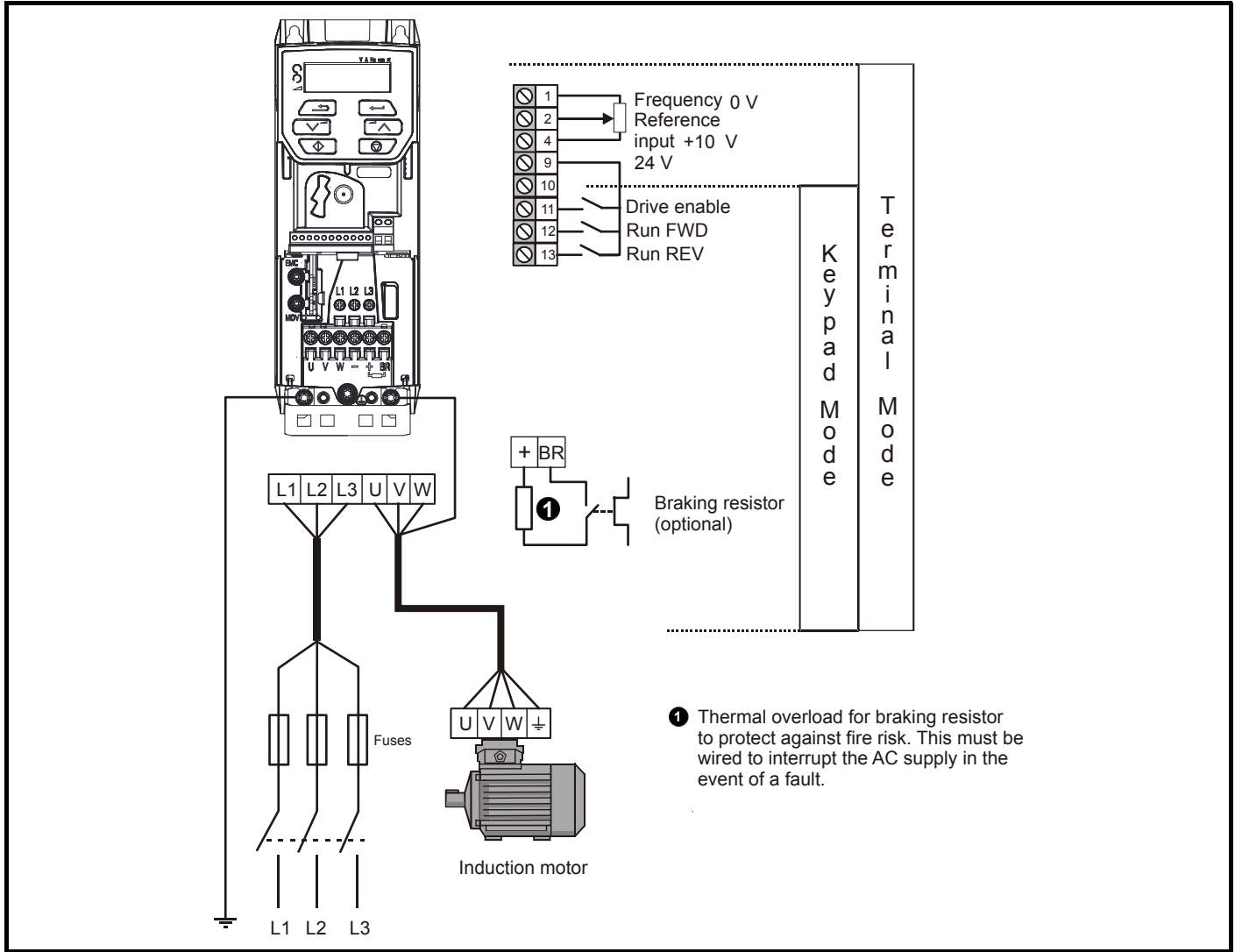

## 7.2 Quick start commissioning / start-up

### 7.2.1 Open loop

Action	Detail																																																																			
Before power-up	Ensure: <ul style="list-style-type: none"> <li>The drive enable signal is not given (terminal 11)</li> <li>Run signal is not given</li> <li>Motor is connected</li> </ul>																																																																			
Power-up the drive	Ensure: <ul style="list-style-type: none"> <li>Drive displays 'inh'</li> </ul> If the drive trips, see section 12 <i>Diagnostics</i> on page 116.																																																																			
Enter motor nameplate details	Enter: <ul style="list-style-type: none"> <li>Motor rated frequency in Pr <b>00.039</b> (Hz)</li> <li>Motor rated current in Pr <b>00.006</b> (A)</li> <li>Motor rated speed in Pr <b>00.007</b> (rpm)</li> <li>Motor rated voltage in Pr <b>00.008</b> (V) - check if <math>\Delta</math> or <math>\lambda</math> connection</li> </ul>	<table border="1"> <tr> <td colspan="6">Mot X XXXXXXXXXX</td> </tr> <tr> <td colspan="6">No XXXXXXXXXX kg</td> </tr> <tr> <td>IP55</td> <td>IGF</td> <td>°C</td> <td>40</td> <td>s</td> <td>S1</td> </tr> <tr> <td>V</td> <td>Hz</td> <td>min</td> <td>kW</td> <td>cosφ</td> <td>A</td> </tr> <tr> <td>Δ 230</td> <td>50</td> <td>1445</td> <td>2.20</td> <td>0.80</td> <td>8.50</td> </tr> <tr> <td>λ 400</td> <td></td> <td></td> <td></td> <td></td> <td>4.90</td> </tr> <tr> <td colspan="6">CN = 14.5Nm</td> </tr> <tr> <td>Δ 240</td> <td>50</td> <td>1445</td> <td>2.20</td> <td>0.76</td> <td>8.50</td> </tr> <tr> <td>λ 415</td> <td></td> <td></td> <td></td> <td></td> <td>4.90</td> </tr> <tr> <td colspan="6">CN = 14.4Nm</td> </tr> <tr> <td colspan="6">CTP- VEN 1PHASE I=0.46A P=110W R.F. 32MIN</td> </tr> </table>	Mot X XXXXXXXXXX						No XXXXXXXXXX kg						IP55	IGF	°C	40	s	S1	V	Hz	min	kW	cosφ	A	Δ 230	50	1445	2.20	0.80	8.50	λ 400					4.90	CN = 14.5Nm						Δ 240	50	1445	2.20	0.76	8.50	λ 415					4.90	CN = 14.4Nm						CTP- VEN 1PHASE I=0.46A P=110W R.F. 32MIN					
Mot X XXXXXXXXXX																																																																				
No XXXXXXXXXX kg																																																																				
IP55	IGF	°C	40	s	S1																																																															
V	Hz	min	kW	cosφ	A																																																															
Δ 230	50	1445	2.20	0.80	8.50																																																															
λ 400					4.90																																																															
CN = 14.5Nm																																																																				
Δ 240	50	1445	2.20	0.76	8.50																																																															
λ 415					4.90																																																															
CN = 14.4Nm																																																																				
CTP- VEN 1PHASE I=0.46A P=110W R.F. 32MIN																																																																				
Set maximum frequency	Enter: <ul style="list-style-type: none"> <li>Maximum frequency in Pr <b>00.002</b> (Hz)</li> </ul>																																																																			
Set acceleration / deceleration rates	Enter: <ul style="list-style-type: none"> <li>Acceleration rate in Pr <b>00.003</b> (s/100 Hz)</li> <li>Deceleration rate in Pr <b>00.004</b> (s/100 Hz) (If braking resistor installed, set Pr <b>00.028</b> = FAST. Also ensure Pr <b>10.030</b> and Pr <b>10.031</b> and Pr <b>10.061</b> are set correctly, otherwise premature 'lt.br' trips may be seen).</li> </ul>																																																																			
Autotune	<p>The drive is able to perform either a stationary or a rotating autotune. The motor must be at a standstill before an autotune is enabled. A rotating autotune should be used whenever possible so the measured value of power factor of the motor is used by the drive.</p> <div style="border: 1px solid black; padding: 5px;"> <p><b>WARNING</b> A rotating autotune will cause the motor to accelerate up to <math>2/3</math> base speed in the direction selected regardless of the reference provided. Once complete the motor will coast to a stop. The enable signal must be removed before the drive can be made to run at the required reference.</p> <p>The drive can be stopped at any time by removing the run signal or removing the drive enable.</p> </div> <ul style="list-style-type: none"> <li>A stationary autotune can be used when the motor is loaded and it is not possible to uncouple the load from the motor shaft. A stationary autotune measures the stator resistance of the motor and the dead time compensation for the drive. These are required for good performance in vector control modes. A stationary autotune does not measure the power factor of the motor so the value on the motor nameplate must be entered into Pr <b>00.009</b>.</li> <li>A rotating autotune should only be used if the motor is uncoupled. A rotating autotune first performs a stationary autotune before rotating the motor at <math>2/3</math> base speed in the direction selected. The rotating autotune measures the power factor of the motor.</li> </ul> <p>To perform an autotune:</p> <ul style="list-style-type: none"> <li>Set Pr <b>00.038</b> = 1 for a stationary autotune or set Pr <b>00.038</b> = 2 for a rotating autotune</li> <li>Close the Drive Enable signal (apply +24 V to terminal 11). The drive will display 'rdy'.</li> <li>Close the run signal (apply +24 V to terminal 12 or 13). The display will flash 'tuning' while the drive is performing the autotune.</li> <li>Wait for the drive to display 'inh' and for the motor to come to a standstill.</li> </ul> <p>If the drive trips, see Chapter 12 <i>Diagnostics</i> on page 116.</p> <ul style="list-style-type: none"> <li>Remove the drive enable and run signal from the drive.</li> </ul>																																																																			
Save parameters	Select 'Save' in Pr <b>mm.000</b> (alternatively enter a value of 1000 in Pr <b>mm.000</b> ) and press the red  reset button.																																																																			
Run	Drive is now ready to run																																																																			

## 8 Optimization

This chapter takes the user through methods of optimizing the drive set-up and maximize the performance. The auto-tuning features of the drive simplify the optimization tasks.

### 8.1 Motor map parameters

#### 8.1.1 Open loop motor control

<b>Pr 00.006 {05.007} Motor Rated Current</b>	<b>Defines the maximum continuous motor current</b>
<ul style="list-style-type: none"> <li>The rated current parameter must be set to the maximum continuous current of the motor. The motor rated current is used in the following:</li> <li>Current limits (see section section 8.3 <i>Current limits</i> on page 65, for more information)</li> <li>Motor thermal overload protection (see section section 8.4 <i>Motor thermal protection</i> on page 65, for more information)</li> <li>Vector mode voltage control (see <i>Control Mode</i> later in this table)</li> <li>Slip compensation (see <i>Enable Slip Compensation</i> (05.027), later in this table)</li> <li>Dynamic V/F control</li> </ul>	
<b>Pr 00.008 {05.009} Motor Rated Voltage</b>	<b>Defines the voltage applied to the motor at rated frequency</b>
<b>Pr 00.039 {05.006} Motor Rated Frequency</b>	<b>Defines the frequency at which rated voltage is applied</b>
<p>The <i>Motor Rated Voltage</i> (00.008) and the <i>Motor Rated Frequency</i> (00.039) are used to define the voltage to frequency characteristic applied to the motor (see <i>Control Mode</i>, later in this table). The <i>Motor Rated Frequency</i> is also used in conjunction with the motor rated speed to calculate the rated slip for slip compensation (see <i>Motor Rated Speed</i>, later in this table).</p>	
<p>The graph shows a linear relationship between output voltage and output frequency. The y-axis is labeled 'Output voltage' and has two marked points: 'Pr 00.008 / 2' and 'Pr 00.008'. The x-axis is labeled 'Output frequency' and has two marked points: 'Pr 00.039 / 2' and 'Pr 00.039'. A solid line starts at the origin (0,0) and goes up to the point (Pr 00.039, Pr 00.008). From that point, the line becomes horizontal, extending to the right. Dotted lines connect the marked points on the axes to the line.</p>	
<b>Pr 00.007 {05.008} Motor Rated Speed</b>	<b>Defines the full load rated speed of the motor</b>
<b>Pr 00.040 {05.011} Number of Motor Poles</b>	<b>Defines the number of motor poles</b>
<p>The motor rated speed and the number of poles are used with the motor rated frequency to calculate the rated slip of induction machines in Hz.</p> $\text{Rated slip (Hz)} = \text{Motor rated frequency} - (\text{Number of pole pairs} \times [\text{Motor rated speed} / 60]) = 00.039 = \left( \frac{00.040}{2} \times \frac{00.007}{60} \right)$ <p>If Pr 00.007 is set to 0 or to synchronous speed, slip compensation is disabled. If slip compensation is required this parameter should be set to the nameplate value, which should give the correct rpm for a hot machine. Sometimes it will be necessary to adjust this when the drive is commissioned because the nameplate value may be inaccurate. Slip compensation will operate correctly both below base speed and within the field-weakening region. Slip compensation is normally used to correct for the motor speed to prevent speed variation with load. The rated load rpm can be set higher than synchronous speed to deliberately introduce speed droop. This can be useful to aid load sharing with mechanically coupled motors.</p> <p>Pr 00.040 is also used in the calculation of the motor speed display by the drive for a given output frequency. When Pr 00.040 is set to 'Auto', the number of motor poles is automatically calculated from the rated frequency Pr 00.039, and the motor rated speed Pr 00.007.</p> $\text{Number of poles} = 120 \times (\text{Rated Frequency} (00.039) / \text{Rated Speed} (00.007)) \text{ rounded to the nearest even number.}$	
<b>Pr 00.043 {05.010} Motor Rated Power Factor</b>	<b>Defines the angle between the motor voltage and current</b>
<p>The power factor is the true power factor of the motor, i.e. the angle between the motor voltage and current. The power factor is used in conjunction with the <i>Motor Rated Current</i> (00.006), to calculate the rated active current and magnetising current of the motor. The rated active current is used extensively to control the drive, and the magnetising current is used in vector mode stator resistance compensation. It is important that this parameter is set up correctly. The drive can measure the motor rated power factor by performing a rotating autotune (see Autotune (Pr 00.038), below).</p>	

### Pr 00.038 {05.012} Autotune

There are two autotune tests available in open loop mode, a stationary and a rotating test. A rotating autotune should be used whenever possible so the measured value of power factor of the motor is used by the drive.

- A stationary autotune can be used when the motor is loaded and it is not possible to remove the load from the motor shaft. The stationary test measures the *Stator Resistance* (05.017), *Transient Inductance* (05.024), *Maximum Deadtime Compensation* (05.059) and *Current At Maximum Deadtime Compensation* (05.060) which are required for good performance in vector control modes (see *Control Mode* later in this table). The stationary autotune does not measure the power factor of the motor so the value on the motor nameplate must be entered into Pr 00.009. To perform a Stationary autotune, set Pr 00.038 to 1, and provide the drive with both an enable signal (on terminal 11) and a run signal (on terminals 12 or 13).
- A rotating autotune should only be used if the motor is unloaded. A rotating autotune first performs a stationary autotune, as above, then a rotating test is performed in which the motor is accelerated with currently selected ramps up to a frequency of *Motor Rated Frequency* (05.006) x 2/3, and the frequency is maintained at that level for 4 seconds. *Stator Inductance* (05.025) is measured and this value is used in conjunction with other motor parameters to calculate *Motor Rated Power Factor* (05.010). To perform a Rotating autotune, set Pr 00.038 to 2, and provide the drive with both an enable signal (on terminal 11) and a run signal (on terminals 12 or 13).

Following the completion of an autotune test the drive will go into the inhibit state. The drive must be placed into a controlled disable condition before the drive can be made to run at the required reference. The drive can be put in to a controlled disable condition by removing the signal from terminal 11, setting the *Drive Enable* (06.015) to OFF (0).

### Pr 00.041 {05.014} Control Mode

There are several voltage modes available which fall into two categories, vector control and fixed boost.

#### Vector control

Vector control mode provides the motor with a linear voltage characteristic from 0 Hz to *Motor Rated Frequency*, and then a constant voltage above motor rated frequency. When the drive operates between motor rated frequency/50 and motor rated frequency/4, full vector based stator resistance compensation is applied. When the drive operates between motor rated frequency/4 and motor rated frequency/2 the stator resistance compensation is gradually reduced to zero as the frequency increases. For the vector modes to operate correctly the *Motor Rated Power Factor*, *Stator Resistance* (05.017), *Maximum Deadtime Compensation* (05.059) and current at *Maximum Deadtime Compensation* (05.060) are all required to be set up accurately. The drive can be made to measure these by performing an autotune (see Pr 00.038 *Autotune*). The drive can also be made to measure the stator resistance automatically every time the drive is enabled or the first time the drive is enabled after it is powered up, by selecting one of the vector control voltage modes.

(0) **Ur S** = The stator resistance is measured and the parameters for the selected motor map are over-written each time the drive is made to run. This test can only be done with a stationary motor where the flux has decayed to zero. Therefore this mode should only be used if the motor is guaranteed to be stationary each time the drive is made to run. To prevent the test from being done before the flux has decayed there is a period of 1 second after the drive has been in the ready state during which the test is not done if the drive is made to run again. In this case, previously measured values are used. Ur S mode ensures that the drive compensates for any change in motor parameters due to changes in temperature. The new value of stator resistance is not automatically saved to the drive's EEPROM.

(4) **Ur I** = The stator resistance is measured when the drive is first made to run after each power-up. This test can only be done with a stationary motor. Therefore this mode should only be used if the motor is guaranteed to be stationary the first time the drive is made to run after each power-up. The new value of stator resistance is not automatically saved to the drive's EEPROM.

(1) **Ur** = The stator resistance and voltage offset are not measured. The user can enter the motor and cabling resistance into the *Stator Resistance* (05.017). However this will not include resistance effects within the drive inverter. Therefore if this mode is to be used, it is best to use an autotune test initially to measure the stator resistance.

(3) **Ur\_Auto** = The stator resistance is measured once, the first time the drive is made to run. After the test has been completed successfully the *Control Mode* (00.041) is changed to Ur mode. The *Stator Resistance* (05.017) parameter is written to, and along with the *Control Mode* (00.041), are saved in the drive's EEPROM. If the test fails, the voltage mode will stay set to Ur Auto and the test will be repeated next time the drive is made to run.

#### Fixed boost

The stator resistance is not used in the control of the motor, instead a fixed characteristic with low frequency voltage boost as defined by Pr 00.042, is used. Fixed boost mode should be used when the drive is controlling multiple motors. There are two settings of fixed boost available:

(2) **Fixed** = This mode provides the motor with a linear voltage characteristic from 0 Hz to *Motor Rated Frequency* (00.039), and then a constant voltage above rated frequency.

(5) **Square** = This mode provides the motor with a square law voltage characteristic from 0 Hz to *Motor Rated Frequency* (00.039), and then a constant voltage above rated frequency. This mode is suitable for variable torque applications like fans and pumps where the load is proportional to the square of the speed of the motor shaft. This mode should not be used if a high starting torque is required.

### Pr 00.041 {05.014} Control Mode (cont)

For both these modes, at low frequencies (from 0 Hz to  $\frac{1}{2}$  x Pr 00.039) a voltage boost is applied as defined by Pr 00.042 as shown below:

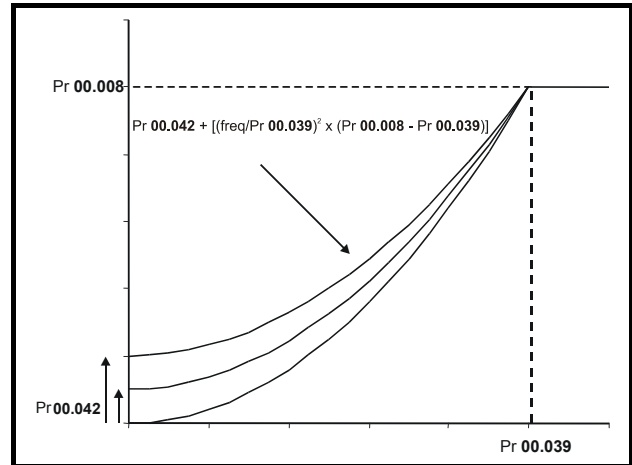
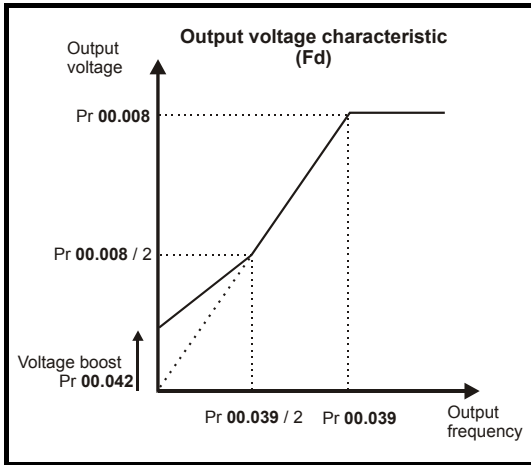

### Pr 05.027 Enable Slip Compensation

When a motor, being controlled in open loop mode, has load applied a characteristic of the motor is that the output speed droops in proportion to the load applied as shown:

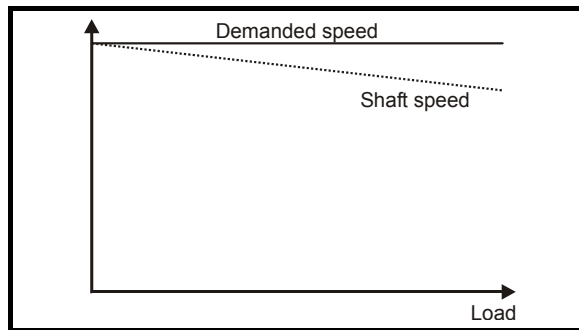

In order to prevent the speed droop shown above slip compensation should be enabled. To enable slip compensation Pr 05.027 must be set to a 1 (this is the default setting), and the motor rated speed must be entered in Pr 00.007 (Pr 05.008).

The motor rated speed parameter should be set to the synchronous speed of the motor minus the slip speed. This is normally displayed on the motor nameplate, i.e. for a typical 18.5 kW, 50 Hz, 4 pole motor, the motor rated speed would be approximately 1465 rpm. The synchronous speed for a 50 Hz, 4 pole motor is 1500 rpm, so therefore the slip speed would be 35 rpm. If the synchronous speed is entered in Pr 00.007, slip compensation will be disabled. If too small a value is entered in Pr 00.007, the motor will run faster than the demanded frequency. The synchronous speeds for 50 Hz motors with different numbers of poles are as follows:

2 pole = 3000 rpm, 4 pole = 1500 rpm, 6pole = 1000 rpm, 8 pole = 750 rpm



## 8.2 Maximum motor rated current

The maximum motor rated current is the *Maximum Heavy Duty Current Rating* (11.032).

The values for the Heavy Duty rating can be found in section 2.2 *Ratings* on page 10.

## 8.3 Current limits

The default setting for the current limit parameters for size 1 to 4 is:

- 165 % x motor rated current for open loop mode

There are three parameters which control the current limits:

- Motoring current limit: power flowing from the drive to the motor
- Regen current limit: power flowing from the motor to the drive
- Symmetrical current limit: current limit for both motoring and regen operation

The lowest of either the motoring and regen current limit, or the symmetrical current limit applies.

The maximum setting of these parameters depends on the values of motor rated current, drive rated current and the power factor.

The drive can be oversized to permit a higher current limit setting to provide higher accelerating torque as required up to a maximum of 1000 %.

## 8.4 Motor thermal protection

A time constant thermal model is provided to estimate the motor temperature as a percentage of its maximum allowed temperature.

The motor thermal protection is modelled using losses in the motor. The losses in the motor are calculated as a percentage value, so that under these conditions the *Motor Protection Accumulator* (04.019) would eventually reach 100 %.

$$\text{Percentage losses} = 100 \% \times [\text{Load related losses}]$$

Where:

$$\text{Load related losses} = I / (K_1 \times I_{\text{Rated}})^2$$

Where:

$$I = \text{Current Magnitude (04.001)}$$

$$I_{\text{Rated}} = \text{Motor Rated Current (05.007)}$$

If *Motor Rated Current* (05.007)  $\leq$  *Maximum Heavy Duty Current* (11.032)

**Figure 8-1 Motor thermal protection (Heavy Duty)**

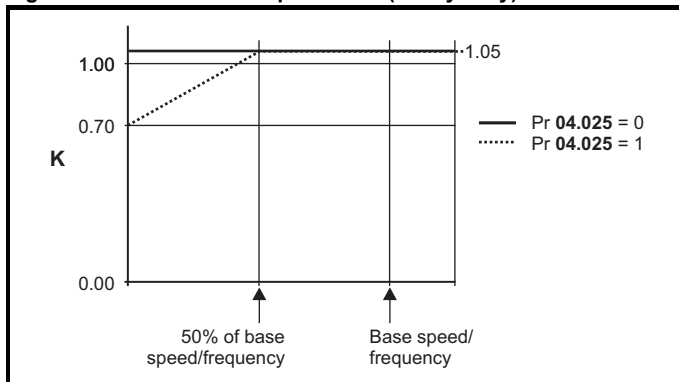

If Pr **04.025** is 0 the characteristic is for a motor which can operate at rated current over the whole speed range. Induction motors with this type of characteristic normally have forced cooling. If Pr **04.025** is 1 the characteristic is intended for motors where the cooling effect of motor fan reduces with reduced motor speed below 50 % of base speed/frequency. The maximum value for K1 is 1.05, so that above the knee of the characteristics the motor can operate continuously up to 105 % current.

When the estimated temperature in Pr **04.019** reaches 100 % the drive takes some action depending on the setting of Pr **04.016**. If Pr **04.016** is 0, the drive trips when Pr **04.019** reaches 100 %. If Pr **04.016** is 1, the current limit is reduced to  $(K - 0.05) \times 100 \%$  when Pr **04.019** reaches 100 %.

The current limit is set back to the user defined level when Pr **04.019** falls below 95 %. The thermal model temperature accumulator is reset to zero at power-up and accumulates the temperature of the motor while the drive remains powered-up. If the rated current defined by Pr **05.007** is altered, the accumulator is reset to zero.

The default setting of the thermal time constant (Pr **04.015**) is 179 s which is equivalent to an overload of 150 % for 120 s from cold.

## 8.5 Switching frequency

The default switching frequency is 3 kHz, however this can be increased up to a maximum of 16 kHz by Pr **05.018** (dependent on drive size). The available switching frequencies are shown below.

**Table 8-1 Available switching frequencies**

Drive size	Model	0.667 kHz	1 kHz	2 kHz	3 kHz	4 kHz	6 kHz	8 kHz	12 kHz	16 kHz
1	All	✓	✓	✓	✓	✓	✓	✓	✓	✓
2										
3										
4										

If switching frequency is increased from 3 kHz the following apply:

1. Increased heat loss in the drive, which means that derating to the output current must be applied.  
See the derating tables for switching frequency and ambient temperature in section 11.1.1 *Power and current ratings (Derating for switching frequency and temperature)* on page 103.
2. Reduced heating of the motor - due to improved output waveform quality.
3. Reduced acoustic noise generated by the motor.
4. Increased sample rate on the speed and current controllers. A trade off must be made between motor heating, drive heating and the demands of the application with respect to the sample time required.

**Table 8-2 Sample rates for various control tasks at each switching frequency**

	0.667, 1 kHz	3, 6, 12 kHz	2, 4, 8, 16 kHz	Open loop
Level 1	250 $\mu$ s	167 $\mu$ s	2 kHz = 250 $\mu$ s 4 kHz = 125 $\mu$ s 8 kHz = 125 $\mu$ s 16 kHz = 125 $\mu$ s	Peak limit
Level 2	250 $\mu$ s			Current limit and ramps
Level 3	1 ms			Voltage controller
Level 4	4 ms			Time critical user interface
Background				Non-time critical user interface

### 8.5.1 Field weakening (constant power) operation

The drive can be used to run an induction machine above synchronous speed into the constant power region. The speed continues to increase and the available shaft torque reduces. The characteristics below show the torque and output voltage characteristics as the speed is increased above the rated value.

**Figure 8-2 Torque and rated voltage against speed**

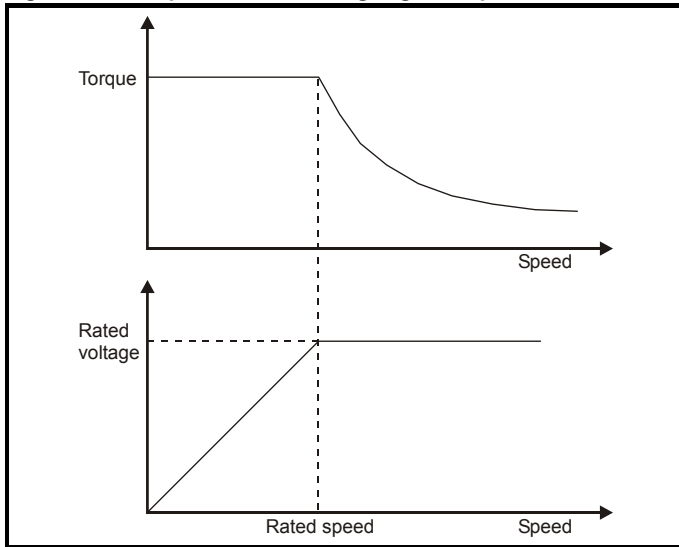

Care must be taken to ensure the torque available above base speed is sufficient for the application to run satisfactorily.

### 8.5.2 Maximum frequency

In all operating modes the maximum output frequency is limited to 550 Hz.

### 8.5.3 Over-modulation

The maximum output voltage level of the drive is normally limited to an equivalent of the drive input voltage minus voltage drops within the drive (the drive will also retain a few percent of the voltage in order to maintain current control). If the motor rated voltage is set at the same level as the supply voltage, some pulse deletion will occur as the drive output voltage approaches the rated voltage level. If Pr **05.020** (Over-modulation enable) is set to 1 the modulator will allow over modulation, so that as the output frequency increases beyond the rated frequency the voltage continues to increase above the rated voltage. The modulation depth will increase beyond unity; first producing trapezoidal and then quasi-square waveforms.

This can be used for example:

- To obtain high output frequencies with a low switching frequency which would not be possible with space vector modulation limited to unity modulation depth,

or

- In order to maintain a higher output voltage with a low supply voltage.

The disadvantage is that the machine current will be distorted as the modulation depth increases above unity, and will contain a significant amount of low order odd harmonics of the fundamental output frequency. The additional low order harmonics cause increased losses and heating in the motor.

## 9 NV Media Card

### 9.1 Introduction

The Non-Volatile Media Card feature enables simple configuration of parameters, parameter back-up and drive cloning using an SD card.

The SD card can be used for:

- Parameter copying between drives
- Saving drive parameter sets

The NV Media Card (SD card) is located in the AI-Backup Adaptor.

The drive only communicates with the NV Media Card when commanded to read or write, meaning the card may be "hot swapped".

**Figure 9-1 Installation of the SD card**

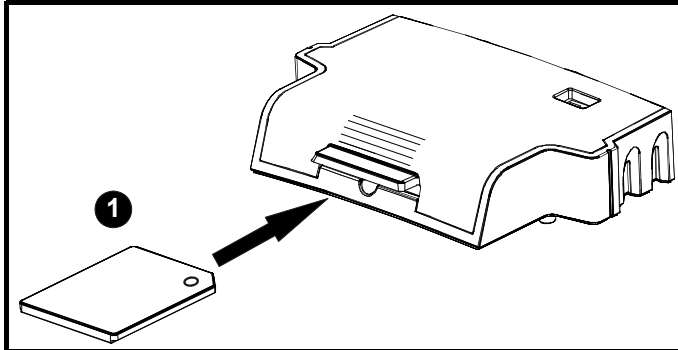

1. Installing the SD card

#### NOTE

A flat bladed screwdriver or similar tool is required in order to insert/remove the SD card fully into/ remove from the AI-Backup Adaptor.

To insert/remove the SD card into/from the AI-Backup Adaptor, the AI-Backup Adaptor will need to be removed from the drive.

### 9.2 SD card support

An SD memory card can be inserted in the AI-Backup Adaptor in order to transfer data to the drive, however the following limitations should be noted:

If a parameter from the source drive does not exist in the target drive then no data is transferred for that parameter.

If the data for the parameter in the target drive is out of range then the data is limited to the range of the target parameter.

If the target drive has a different rating to the source drive then the normal rules for this type of transfer apply as described later.

No checking is possible to determine if the source and target product types are the same, and so no warning is given if they are different.

If an SD card is used then the drive will recognise the following file types through the drive parameter interface.

File Type	Description
Parameter file	A file that contains all clonable user save parameters from the drive menus (1 to 30) in difference from default format
Macro file	The same as a parameter file, but defaults are not loaded before the data is transferred from the card

These files can be created on a card by the drive and then transferred to any other drive including derivatives. If the Drive Derivative (11.028) is different between the source and target drives then the data is transferred but a {C.Pr} trip is initiated.

It is possible for other data to be stored on the card, but this should not be stored in the <MCDF> folder and it will not be visible via the drive parameter interface.

#### 9.2.1 Changing the drive mode

If the source drive mode is different from the target drive mode then the mode will be changed to the source drive mode before the parameters are transferred. If the required drive mode is outside the allowed range for the target then a {C.typ} trip is initiated and no data is transferred.

#### 9.2.2 Different voltage ratings

If the voltage rating of the source and target drives is different then all parameters except those that are rating dependent (i.e. attribute RA=1) are transferred to the target drive. The rating dependent parameters are left at their default values. After the parameters have been transferred and saved to non-volatile memory a {C.rtg} trip is given as a warning. The table below gives a list of the rating dependent parameters.

Parameters
Standard Ramp Voltage (02.008)
Motoring Current Limit (04.005)
Regenerating Current Limit (04.006)
Symmetrical Current Limit (04.007)
User Current Maximum Scaling (04.024)
Motor Rated Current (05.007)
Motor Rated Voltage (05.009)
Motor Rated Power Factor (05.010)
Stator Resistance (05.017)
Maximum Switching Frequency (05.018)
Transient Inductance /Ld (05.024)
Stator Inductance (05.025)
Injection Braking Level (06.006)
Supply Loss Detection Level (06.048)

### 9.2.3 Different current ratings

If any of the current rating parameters (Maximum Heavy Duty Rating (11.032), Maximum Rated Current (11.060) or Full Scale Current Kc (11.061)) are different between the source and target then all parameters are still written to the target drive, but some may be limited by their allowed range. To give similar performance in the target compared to the source drive the current controller gains are modified as shown below. Note that this does not apply if the file identification number is larger than 500.

Gains	Multiplier
Current Controller Kp Gain (04.013)	[Source Full Scale Current Kc (11.061)] /
Current Controller Ki Gain (04.014)	[Target Full Scale Current Kc (11.061)]

### 9.2.4 Different variable maximums

It should be noted that if ratings of the source and target drives are different, it is possible that some parameters with variable maximums may be limited and not have the same values as in the source drive.

### 9.2.5 Macro files

Macro files are created in the same way as parameter files except that *NV Media Card Create Special File* (11.072) must be set to 1 before the file is created on the NV media card. *NV Media Card Create Special File* (11.072) is set to zero after the file has been created or the transfer fails. When a macro file is transferred to a drive the drive mode is not changed even if the actual mode is different to that in the file and defaults are not loaded before the parameters are copied from the file to the drive.

## 9.3 NV Media Card parameters

Table 9-1 Key to parameter table coding

RW	Read / Write	ND	No default value
RO	Read only	NC	Not copied
Num	Number parameter	PT	Protected parameter
Bit	Bit parameter	RA	Rating dependant
Txt	Text string	US	User save
Bin	Binary parameter	PS	Power-down save
FI	Filtered	DE	Destination

11.036		NV Media Card File Previously Loaded			
RO	Num	NC	PT		
⇕	0 to 999		⇒		0

This parameter shows the number of the data block last transferred from an SD card to the drive. If defaults are subsequently reloaded this parameter is set to 0.

11.037		NV Media Card File Number			
RW	Num				
⇕	0 to 999		⇒		0

This parameter should have the data block number which the user would like the information displayed in Pr 11.038, Pr 11.039.

11.038		NV Media Card File Type			
RO	Txt	ND	NC	PT	
⇕	0 to 1			⇒	0

Displays the type/mode of the data block selected with Pr 11.037.

Pr 11.038	String	Type / mode
0	None	No file selected
1	Open-loop	Open-Loop mode parameter file

11.039		NV Media Card File Version			
RO	Num	ND	NC	PT	
⇕	0 to 9999			⇒	0

Displays the version number of the file selected in Pr 11.037.

11.042		Parameter Cloning			
RW	Txt		NC		US*
⇕	None (0), Read (1), Prog (2), Auto (3), Boot (4)			⇒	0

## 9.4 NV Media Card trips

After an attempt to read, write or erase data from a NV Media Card a trip is initiated if there has been a problem with the command.

See Chapter 12 *Diagnostics* on page 116 for more information on NV Media Card trips.

# 10 Advanced parameters

Full descriptions of the parameters can be found in the *Parameter Reference Guide*.



**WARNING**

These advanced parameters are listed for reference purposes only. The lists in this chapter do not include sufficient information for adjusting these parameters. Incorrect adjustment can affect the safety of the system, and damage the drive and or external equipment. Before attempting to adjust any of these parameters, refer to the *Parameter reference guide*.

**Table 10-1 Menu descriptions**

Menu	Description
0	Commonly used basic set up parameters for quick / easy programming
1	Frequency reference
2	Ramps
3	Frequency control
4	Torque and current control
5	Motor control
6	Sequencer and clock
7	Analog I/O
8	Digital I/O
10	Status and trips
11	Drive set-up and identification
22	Menu 0 set-up

**Operation mode abbreviations:**

**Open-loop:** Sensorless control for induction motors

**Default abbreviations:**

Standard default value (50 Hz AC supply frequency)

USA default value (60 Hz AC supply frequency)

**NOTE**

Parameter numbers shown in brackets {...} are the equivalent Menu 0 parameters. Some Menu 0 parameters appear twice since their function depends on the operating mode.

In some cases, the function or range of a parameter is affected by the setting of another parameter. The information in the lists relates to the default condition of any parameters affected in this way.

**Table 10-2 Key to parameter table coding**

Coding	Attribute
<b>RW</b>	Read/Write: can be written by the user
<b>RO</b>	Read only: can only be read by the user
<b>Bit</b>	1 bit parameter. 'On' or 'Off' on the display
<b>Num</b>	Number: can be uni-polar or bi-polar
<b>Txt</b>	Text: the parameter uses text strings instead of numbers.
<b>Bin</b>	Binary parameter
<b>Date</b>	Date parameter
<b>Time</b>	Time parameter
<b>FI</b>	Filtered: some parameters which can have rapidly changing values are filtered when displayed on the drive keypad for easy viewing.
<b>DE</b>	Destination: This parameter selects the destination of an input or logic function.
<b>RA</b>	Rating dependent: this parameter is likely to have different values and ranges with drives of different voltage and current ratings. Parameters with this attribute will be transferred to the destination drive by non-volatile storage media when the rating of the destination drive is different from the source drive and the file is a parameter file. However, the values will be transferred if only the current rating is different and the file is a difference from default type file.
<b>ND</b>	No default: The parameter is not modified when defaults are loaded
<b>NC</b>	Not copied: not transferred to or from non-volatile media during copying.
<b>PT</b>	Protected: cannot be used as a destination.
<b>US</b>	User save: parameter saved in drive EEPROM when the user initiates a parameter save.
<b>PS</b>	Power-down save: parameter automatically saved in drive EEPROM when the under volts (UV) trip occurs.

**Table 10-3 Feature look-up table**

Features	Related parameters (Pr)												
Acceleration rates	02.010	02.011 to 02.019		02.032	02.033	02.034							
Analog I/O	Menu 7												
Analog input 1	07.001	07.007	07.008	07.009	07.010	07.028	07.051	07.030	07.061	07.062	07.063	07.064	
Analog reference 1	01.036	07.01	07.001	07.007	07.008	07.009	07.028	07.051	07.03	07.061	07.062	07.063	07.064
At frequency indicator bit	03.006	03.007	03.009	10.006	10.005	10.007							
Auto reset	10.034	10.035	10.036	10.001									
Autotune	05.012		05.017		05.024	05.025	05.010					05.059	05.060
Bipolar reference	01.010												
Braking	10.011	10.010	10.030	10.031	6.001	02.004		10.012	10.039	10.040	10.061		
Catch a spinning motor	06.009	05.040											
Coast to stop	06.001												
Copying	11.042	11.036 to 11.039											
Cost - per kWh electricity	06.016	06.017	06.024	06.025	06.026		06.027						
Current controller	04.013	04.014											
Current feedback	04.001	04.002	04.017	04.003	04.004	04.020		04.024	04.026	10.008	10.009	10.017	
Current limits	04.005	04.006	04.007	04.018	04.015	04.019	04.016	05.007	05.010	10.008	10.009	10.017	
DC bus voltage	05.005	02.008											
DC injection braking	06.006	06.007	06.001										
Deceleration rates	02.020	02.021 to 02.029		02.004	02.035 to 02.037			02.008	06.001	10.030	10.031	10.039	02.009
Defaults	11.043	11.046											
Digital I/O	Menu 8												
Digital I/O read word	08.020												
Digital I/O T10	08.001	08.011	08.021	08.031	08.081	08.091	08.121						
Digital I/O T11	08.002	08.012	08.022		08.082	08.122							
Digital I/O T12	08.003	08.013	08.023		08.083	08.123							
Digital input T13	08.004	08.014	08.024	08.084	08.124								
Direction	10.013	06.030	06.031	01.003	10.014	02.001		08.003	08.004	10.040			
Drive active	10.002	10.040											
Drive derivative	11.028												
Drive OK	10.001	08.028	08.008	08.018	10.036	10.040							
Dynamic V/F	05.013												
Enable	06.015				06.038								
External trip	10.032												
Fan speed	06.045												
Field weakening - induction motor			01.006										
Filter change	06.019	06.018	06.021	06.022	06.023								
Firmware version	11.029	11.035											
Frequency reference selection	01.014	01.015											
Frequency slaving	03.001												
Hard frequency reference	03.022	03.023											
Heavy duty rating	05.007	11.032											
High stability space vector modulation	05.019												
I/O sequencer	06.004	06.030	06.031	06.032	06.033	06.034	06.042	06.043	06.041				
Jog reference	01.005	02.019	02.029										
Keypad reference	01.017	01.014	01.043	01.051	06.012								

Features	Related parameters (Pr)											
Limit switches	06.035	06.036										
Line power supply loss	06.003	10.015	10.016	05.005								
Maximum frequency	01.006											
Menu 0 set-up				Menu 22								
Minimum frequency	01.007	10.004										
Motor map	05.006	05.007	05.008	05.009	05.01	05.011						
NV media card	11.036 to 11.039			11.042								
Offset reference	01.004	01.038	01.009									
Open loop vector mode	05.014	05.017										
Operating mode		11.031		05.014								
Output	05.001	05.002	05.003	05.004								
Over frequency threshold	03.008											
Over modulation enable	05.020											
Power up parameter	11.022											
Preset speeds	01.015	01.021 to 01.028				01.014	01.042	01.045 to 01.047			01.050	
Ramp (accel / decel) mode	02.004	02.008	06.001		02.003	10.030	10.031	10.039				
Reference selection	01.014	01.015	01.049	01.050	01.001							
Regenerating	10.010	10.011	10.030	10.031	06.001	02.004		10.012	10.039	10.040		
Relay output	08.008	08.018	08.028									
Reset	10.033			10.034	10.035	10.036	10.001					
S ramp	02.006	02.007										
Sample rates	05.018											
Security code	11.030	11.044										
Skip speeds	01.029	01.03	01.031	01.032	01.033	01.034	01.035					
Slip compensation	05.027	05.008										
Status word	10.040											
Supply		05.005	06.046									
Switching frequency	05.018	05.035	07.034	07.035								
Thermal protection - drive	05.018	05.035	07.004	07.005			07.035	10.018				
Thermal protection - motor	04.015	05.007	04.019	04.016	04.025		08.035					
Time - filter change	06.019	06.018	06.021	06.022	06.023							
Time - powered up log	06.020			06.019	06.017	06.018						
Time - run log				06.019	06.017	06.018						
Torque	04.003	04.026										
Torque mode	04.008	04.011										
Trip detection	10.037	10.038	10.020 to 10.029									
Trip log	10.020 to 10.029			10.041 to 10.060				10.070 to 10.079				
Under voltage	05.005	10.016	10.015									
V/F mode	05.015	05.014										
Voltage controller	05.031											
Voltage mode	05.014	05.017		05.015								
Voltage rating	11.033	05.009	05.005									
Voltage supply		06.046	05.005									
Warning	10.019	10.012	10.017	10.018	10.04							
Zero frequency indicator bit	03.005	10.003										

### Parameter ranges and Variable minimum/maximums:

Some parameters in the drive have a variable range with a variable minimum and a variable maximum values which is dependent on one of the following:

- The settings of other parameters
- The drive rating
- The drive mode
- Combination of any of the above

The tables below give the definition of variable minimum/maximum and the maximum range of these.

<b>VM_AC_VOLTAGE</b>		Range applied to parameters showing AC voltage
Units	V	
Range of [MIN]	0	
Range of [MAX]	0 to the value listed below	
Definition	VM_AC_VOLTAGE[MAX] is drive voltage rating dependent. See Table 10-4 on page 75. VM_AC_VOLTAGE[MIN] = 0	

<b>VM_AC_VOLTAGE_SET</b>		Range applied to the AC voltage set-up parameters
Units	V	
Range of [MIN]	0	
Range of [MAX]	0 to the value listed below	
Definition	VM_AC_VOLTAGE_SET[MAX] is drive voltage rating dependent. See Table 10-4 on page 75. VM_AC_VOLTAGE_SET[MIN] = 0	

<b>VM_ACCEL_RATE</b>		Maximum applied to the ramp rate parameters
Units	s / 100 Hz	
Range of [MIN]	Open-loop: 0.0	
Range of [MAX]	Open-loop: 0.0 to 3200.0	
Definition	If Ramp Rate Units (02.039) = 0: VM_ACCEL_RATE[MAX] = 3200.0 If Ramp Rate Units (02.039) = 1: VM_ACCEL_RATE[MAX] = 3200.0 x Pr <b>01.006</b> / 100.0 VM_ACCEL_RATE[MIN] = 0.0	

<b>VM_DC_VOLTAGE</b>		Range applied to parameters showing DC voltage
Units	V	
Range of [MIN]	0	
Range of [MAX]	0 to the value listed below	
Definition	VM_DC_VOLTAGE[MAX] is the full scale d.c. jumper voltage feedback (over voltage trip level) for the drive. This level is drive voltage rating dependent. See Table 10-4 on page 75. VM_DC_VOLTAGE[MIN] = 0	

<b>VM_DC_VOLTAGE_SET</b>		Range applied to DC voltage reference parameters
Units	V	
Range of [MIN]	0	
Range of [MAX]	0 to the value listed below	
Definition	VM_DC_VOLTAGE_SET[MAX] is drive voltage rating dependent. See Table 10-4 on page 75. VM_DC_VOLTAGE_SET[MIN] = 0	

<b>VM_DRIVE_CURRENT</b>		Range applied to parameters showing current in A
Units	A	
Range of [MIN]	-9999.99 to 0.00	
Range of [MAX]	0.00 to 9999.99	
Definition	VM_DRIVE_CURRENT[MAX] is equivalent to the full scale (over current trip level) for the drive and is given by <i>Full Scale Current</i> Kc (11.061). VM_DRIVE_CURRENT[MIN] = - VM_DRIVE_CURRENT[MAX]	



<b>VM_DRIVE_CURRENT_UNIPOLAR</b>		Unipolar version of VM_DRIVE_CURRENT
<b>Units</b>	A	
<b>Range of [MIN]</b>	0.00	
<b>Range of [MAX]</b>	0.00 to 9999.99	
<b>Definition</b>	VM_DRIVE_CURRENT_UNIPOLAR[MAX] = VM_DRIVE_CURRENT[MAX] VM_DRIVE_CURRENT_UNIPOLAR[MIN] = 0.00	

<b>VM_HIGH_DC_VOLTAGE</b>		Range applied to parameters showing high DC voltage
<b>Units</b>	V	
<b>Range of [MIN]</b>	0	
<b>Range of [MAX]</b>	0 to 1500	
<b>Definition</b>	VM_HIGH_DC_VOLTAGE[MAX] is the full scale d.c. jumper voltage feedback for the high d.c. jumper voltage measurement which can measure the voltage if it goes above the normal full scale value. This level is drive voltage rating dependent. See Table 10-4 on page 75.  VM_HIGH_DC_VOLTAGE[MIN] = 0	

<b>VM_MOTOR1_CURRENT_LIMIT</b>		Range applied to current limit parameters
<b>Units</b>	%	
<b>Range of [MIN]</b>	0.0	
<b>Range of [MAX]</b>	0.0 to 1000.0	
<b>Definition</b>	VM_MOTOR1_CURRENT_LIMIT[MIN] = 0.0  <b>Open-loop</b> VM_MOTOR1_CURRENT_LIMIT[MAX] = $(I_{Tlimit} / I_{Trated}) \times 100 \%$ Where: $I_{Tlimit} = I_{MaxRef} \times \cos(\sin^{-1}(I_{Mrated} / I_{MaxRef}))$ $I_{Mrated} = Pr \ 05.007 \sin \phi$ $I_{Trated} = Pr \ 05.007 \times \cos \phi$ $\cos \phi = Pr \ 05.010$ $I_{MaxRef}$ is 0.7 x Pr 11.061 when the motor rated current set in Pr 05.007 is less than or equal to Pr 11.032 (i.e. Heavy duty).	

<b>VM_NEGATIVE_REF_CLAMP1</b>		Limits applied to the negative frequency or speed clamp																		
<b>Units</b>	Hz																			
<b>Range of [MIN]</b>	-550.00 to 0.00																			
<b>Range of [MAX]</b>	0.00 to 550.00																			
<b>Definition</b>	<table border="1"> <thead> <tr> <th><i>Negative Reference Clamp Enable (01.008)</i></th> <th><i>Bipolar Reference Enable (01.010)</i></th> <th><b>VM_NEGATIVE_REF_CLAMP1[MIN]</b></th> <th><b>VM_NEGATIVE_REF_CLAMP1[MAX]</b></th> </tr> </thead> <tbody> <tr> <td>0</td> <td>0</td> <td>0.00</td> <td>Pr 01.006</td> </tr> <tr> <td>0</td> <td>1</td> <td>0.00</td> <td>0.00</td> </tr> <tr> <td>1</td> <td>X</td> <td>-VM_POSITIVE_REF_CLAMP[MAX]</td> <td>0.00</td> </tr> </tbody> </table>				<i>Negative Reference Clamp Enable (01.008)</i>	<i>Bipolar Reference Enable (01.010)</i>	<b>VM_NEGATIVE_REF_CLAMP1[MIN]</b>	<b>VM_NEGATIVE_REF_CLAMP1[MAX]</b>	0	0	0.00	Pr 01.006	0	1	0.00	0.00	1	X	-VM_POSITIVE_REF_CLAMP[MAX]	0.00
<i>Negative Reference Clamp Enable (01.008)</i>	<i>Bipolar Reference Enable (01.010)</i>	<b>VM_NEGATIVE_REF_CLAMP1[MIN]</b>	<b>VM_NEGATIVE_REF_CLAMP1[MAX]</b>																	
0	0	0.00	Pr 01.006																	
0	1	0.00	0.00																	
1	X	-VM_POSITIVE_REF_CLAMP[MAX]	0.00																	

<b>VM_POSITIVE_REF_CLAMP</b>		Limits applied to the positive frequency or speed reference clamp
<b>Units</b>	Hz	
<b>Range of [MIN]</b>	0.00	
<b>Range of [MAX]</b>	550.00	
<b>Definition</b>	VM_POSITIVE_REF_CLAMP[MAX] is fixed at 550.00 VM_POSITIVE_REF_CLAMP[MIN] is fixed at 0.0	

<b>VM_POWER</b>		Range applied to parameters that either set or display power
<b>Units</b>	kW	
<b>Range of [MIN]</b>	-999.99 to 0.00	
<b>Range of [MAX]</b>	0.00 to 999.99	
<b>Definition</b>	<p>VM_POWER[MAX] is rating dependent and is chosen to allow for the maximum power that can be output by the drive with maximum a.c. output voltage, at maximum controlled current and unity power factor.</p> <p>VM_POWER[MAX] = <math>\sqrt{3} \times \text{VM\_AC\_VOLTAGE}[\text{MAX}] \times \text{VM\_DRIVE\_CURRENT}[\text{MAX}] / 1000</math>            VM_POWER[MIN] = -VM_POWER[MAX]</p>	

<b>VM_RATED_CURRENT</b>		Range applied to rated current parameters
<b>Units</b>	A	
<b>Range of [MIN]</b>	0.00	
<b>Range of [MAX]</b>	0.00 to 9999.99	
<b>Definition</b>	<p>VM_RATED_CURRENT [MAX] = <i>Maximum Rated Current</i> (11.060) and is dependent on the drive rating.            VM_RATED_CURRENT [MIN] = 0.00</p>	

<b>VM_FREQ</b>		Range applied to parameters showing frequency
<b>Units</b>	Hz	
<b>Range of [MIN]</b>	-550.00 to 0.00	
<b>Range of [MAX]</b>	0.00 to 550.00	
<b>Definition</b>	<p>This variable minimum/maximum defines the range of frequency monitoring parameters. To allow headroom for overshoot the range is set to twice the range of the frequency references.</p> <p>VM_FREQ[MAX] = 2 x VM_SPEED_FREQ_REF[MAX]            VM_FREQ[MIN] = 2 x VM_SPEED_FREQ_REF[MIN]</p>	

<b>VM_SPEED_FREQ_REF</b>		Range applied to the frequency or speed reference parameters
<b>Units</b>	Hz	
<b>Range of [MIN]</b>	-550.00 to 0.00	
<b>Range of [MAX]</b>	0.00 to 550.00	
<b>Definition</b>	<p>If Pr <b>01.008</b> = 0: VM_SPEED_FREQ_REF[MAX] = Pr <b>01.006</b>            If Pr <b>01.008</b> = 1: VM_SPEED_FREQ_REF[MAX] = Pr <b>01.006</b> or  Pr <b>01.007</b> , whichever is larger.</p> <p>VM_SPEED_FREQ_REF[MIN] = -VM_SPEED_FREQ_REF[MAX].</p>	

<b>VM_SPEED_FREQ_REF_UNIPOLAR</b>		Unipolar version of VM_SPEED_FREQ_REF
<b>Units</b>	Hz	
<b>Range of [MIN]</b>	0.00	
<b>Range of [MAX]</b>	0.00 to 550.00	
<b>Definition</b>	<p>VM_SPEED_FREQ_REF_UNIPOLAR[MAX] = VM_SPEED_FREQ_REF[MAX]            VM_SPEED_FREQ_REF_UNIPOLAR[MIN] = 0.00</p>	

<b>VM_SPEED_FREQ_USER_REFS</b>		Range applied to some Menu 1 reference parameters															
<b>Units</b>	Hz																
<b>Range of [MIN]</b>	-550.00 to 0.00																
<b>Range of [MAX]</b>	0.00 to 550.00																
<b>Definition</b>	<p>VM_SPEED_FREQ_USER_REFS[MAX] = VM_SPEED_FREQ_REF[MAX]</p> <table border="1"> <thead> <tr> <th><i>Negative Reference Clamp Enable (01.008)</i></th> <th><i>Bipolar Reference Enable (01.010)</i></th> <th>VM_SPEED_FREQ_USER_REFS [MIN]</th> </tr> </thead> <tbody> <tr> <td>0</td> <td>0</td> <td>Pr <b>01.007</b></td> </tr> <tr> <td>0</td> <td>1</td> <td>-VM_SPEED_FREQ_REF[MAX]</td> </tr> <tr> <td>1</td> <td>0</td> <td>0.00</td> </tr> <tr> <td>1</td> <td>1</td> <td>-VM_SPEED_FREQ_REF[MAX]</td> </tr> </tbody> </table>		<i>Negative Reference Clamp Enable (01.008)</i>	<i>Bipolar Reference Enable (01.010)</i>	VM_SPEED_FREQ_USER_REFS [MIN]	0	0	Pr <b>01.007</b>	0	1	-VM_SPEED_FREQ_REF[MAX]	1	0	0.00	1	1	-VM_SPEED_FREQ_REF[MAX]
<i>Negative Reference Clamp Enable (01.008)</i>	<i>Bipolar Reference Enable (01.010)</i>	VM_SPEED_FREQ_USER_REFS [MIN]															
0	0	Pr <b>01.007</b>															
0	1	-VM_SPEED_FREQ_REF[MAX]															
1	0	0.00															
1	1	-VM_SPEED_FREQ_REF[MAX]															

<b>VM_STD_UNDER_VOLTS</b>		Range applied the standard under-voltage threshold
Units	V	
Range of [MIN]	0 to 1150	
Range of [MAX]	0 to 1150	
Definition	VM_STD_UNDER_VOLTS[MAX] = VM_DC_VOLTAGE_SET VM_STD_UNDER_VOLTS[MIN] is voltage rating dependent. See Table 10-4 on page 75.	

<b>VM_SUPPLY_LOSS_LEVEL</b>		Range applied to the supply loss threshold
Units	V	
Range of [MIN]	0 to 1150	
Range of [MAX]	0 to 1150	
Definition	VM_SUPPLY_LOSS_LEVEL[MAX] = VM_DC_VOLTAGE_SET[MAX] VM_SUPPLY_LOSS_LEVEL[MIN] is drive voltage rating dependent. See Table 10-4 on page 75.	

<b>VM_TORQUE_CURRENT</b>		Range applied to torque and torque producing current parameters
Units	%	
Range of [MIN]	-1000.0 to 0.0	
Range of [MAX]	0.0 to 1000.0	
Definition	VM_TORQUE_CURRENT[MAX] = VM_MOTOR1_CURRENT_LIMIT[MAX] VM_TORQUE_CURRENT[MIN] = -VM_TORQUE_CURRENT[MAX]	

<b>VM_TORQUE_CURRENT_UNIPOLAR</b>		Unipolar version of VM_TORQUE_CURRENT
Units	%	
Range of [MIN]	0.0	
Range of [MAX]	0.0 to 1000.0	
Definition	VM_TORQUE_CURRENT_UNIPOLAR[MAX] = VM_TORQUE_CURRENT[MAX] VM_TORQUE_CURRENT_UNIPOLAR[MIN] = 0.0	

<b>VM_USER_CURRENT</b>		Range applied to torque reference and percentage load parameters with one decimal place
Units	%	
Range of [MIN]	-1000.0 to 0.0	
Range of [MAX]	0.0 to 1000.0	
Definition	VM_USER_CURRENT[MAX] = <i>User Current Maximum Scaling</i> (04.024) VM_USER_CURRENT[MIN] = -VM_USER_CURRENT[MAX]	

Table 10-4 Voltage ratings dependant values

Variable min/max	Voltage level (V)				
	100 V	200 V	400 V	575 V	690 V
VM_DC_VOLTAGE_SET(MAX)	410		800	955	1150
VM_DC_VOLTAGE(MAX)	415		830	990	1190
VM_AC_VOLTAGE_SET(MAX)	240		480	575	690
VM_AC_VOLTAGE(MAX)	325		650	780	930
VM_STD_UNDER_VOLTS[MIN]	175		330	435	435
VM_SUPPLY_LOSS_LEVEL[MIN]	205		410	540	540
VM_HIGH_DC_VOLTAGE	1500			1500	

# 10.1 Menu 1: Frequency reference

Figure 10-1 Menu 1 logic diagram

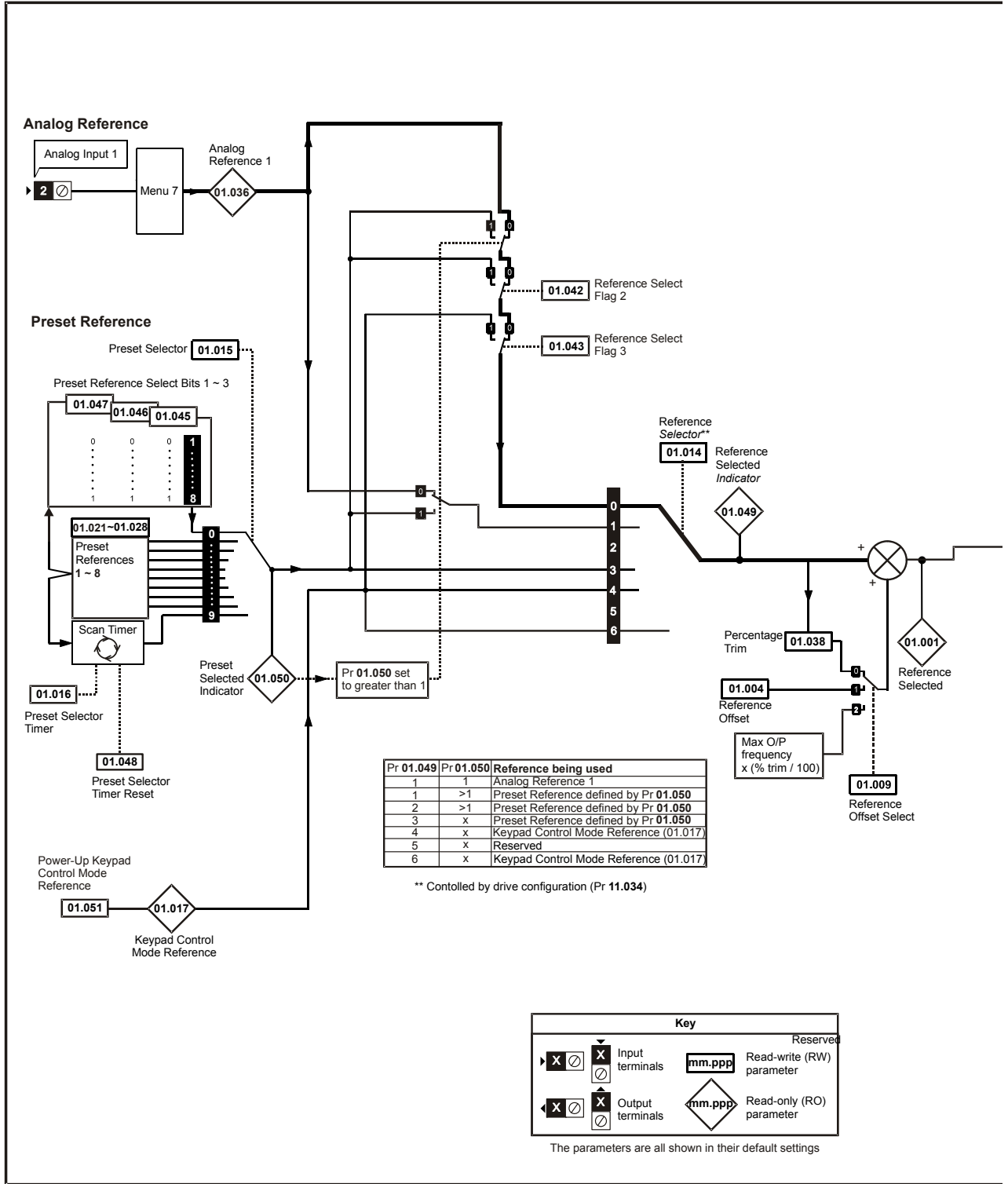

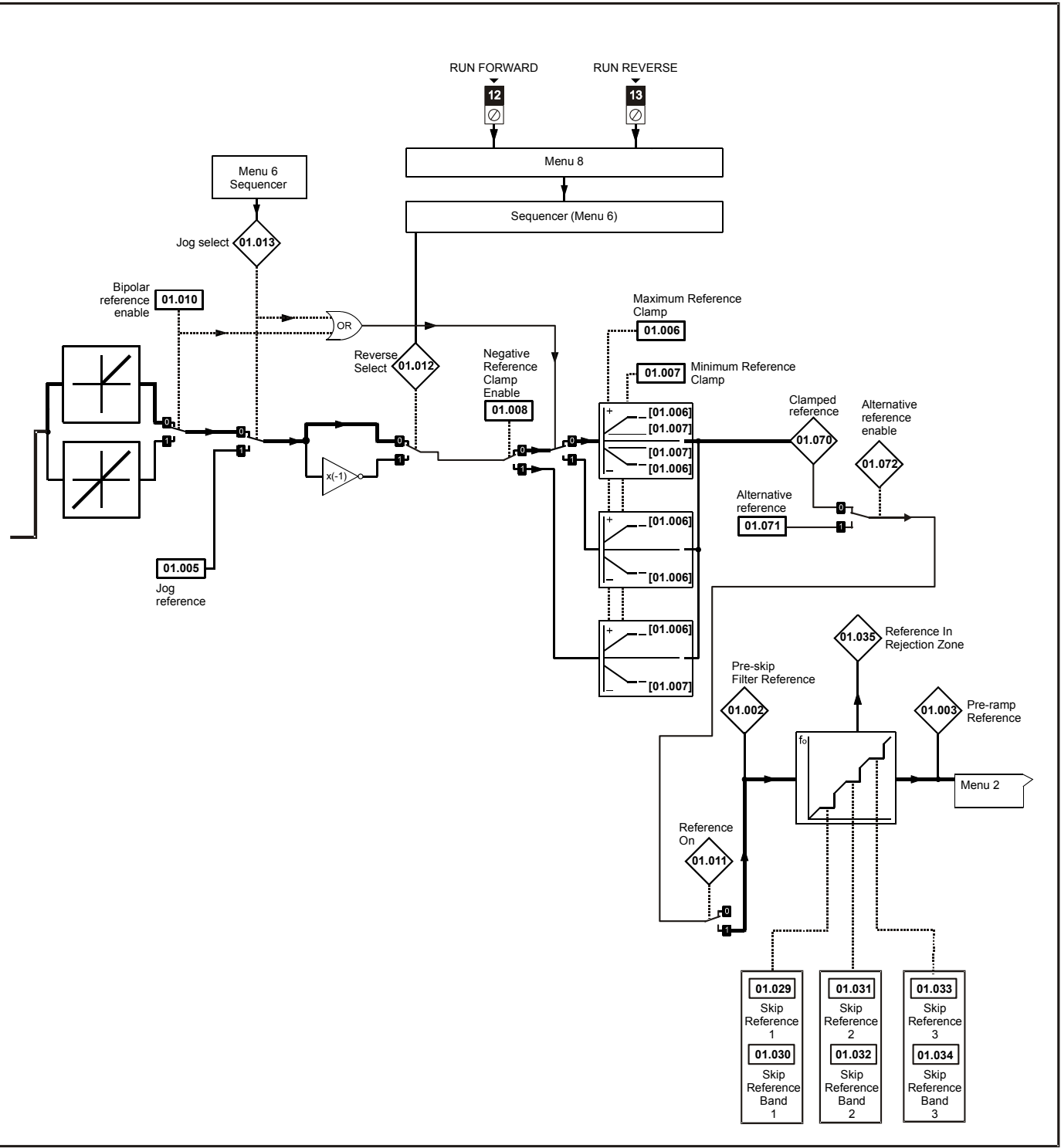

Safety information	Product information	Mechanical installation	Electrical installation	Getting started	Basic parameters	Running the motor	Optimization	NV Media Card	Advanced parameters	Technical data	Diagnostics	UL Listing
--------------------	---------------------	-------------------------	-------------------------	-----------------	------------------	-------------------	--------------	---------------	---------------------	----------------	-------------	------------

Parameter	Range (⇕)		Default (⇨)		Type					
	OL	OL	OL	OL						
01.001	Reference Selected	±VM_SPEED_FREQ_REF Hz			RO	Num	ND	NC	PT	
01.002	Pre-skip Filter Reference	±VM_SPEED_FREQ_REF Hz			RO	Num	ND	NC	PT	
01.003	Pre-ramp Reference	±VM_SPEED_FREQ_REF Hz			RO	Num	ND	NC	PT	
01.004	Reference Offset	±VM_SPEED_FREQ_REF Hz		0.00 Hz	RW	Num				US
01.005	Jog Reference	0.00 to 300.00 Hz		1.50 Hz	RW	Num				US
01.006	Maximum Reference Clamp	±VM_POSITIVE_REF_CLAMP Hz		50 Hz: 50.00 Hz 60 Hz: 60.00 Hz	RW	Num				US
01.007	Minimum Reference Clamp	±VM_NEGATIVE_REF_CLAMP1 Hz		0.00 Hz	RW	Num				US
01.008	Negative Reference Clamp Enable	Off (0) or On (1)		Off (0)	RW	Bit				US
01.009	Reference Offset Select	0 to 2		0	RW	Num				US
01.010	Bipolar Reference Enable	Off (0) or On (1)		Off (0)	RW	Bit				US
01.011	Reference On	Off (0) or On (1)			RO	Bit	ND	NC	PT	
01.012	Reverse Select	Off (0) or On (1)			RO	Bit	ND	NC	PT	
01.013	Jog Select	Off (0) or On (1)			RO	Bit	ND	NC	PT	
01.014	Reference Selector	A1.A2 (0), A1.Pr (1), rES (2), PrESet (3), PAd (4), rES (5), PAd.rEF (6)		A1.A2 (0)	RW	Txt				US
01.015	Preset Selector	0 to 9		0	RW	Num				US
01.016	Preset Selector Timer	0 to 400.0 s		10.0s	RW	Num				US
01.017	Keypad Control Mode Reference	±VM_SPEED_FREQ_USER_REFS Hz			RO	Num		NC	PT	PS
01.021	Preset Reference 1	±VM_SPEED_FREQ_REF Hz		0.00 Hz	RW	Num				US
01.022	Preset Reference 2	±VM_SPEED_FREQ_REF Hz		0.00 Hz	RW	Num				US
01.023	Preset Reference 3	±VM_SPEED_FREQ_REF Hz		0.00 Hz	RW	Num				US
01.024	Preset Reference 4	±VM_SPEED_FREQ_REF Hz		0.00 Hz	RW	Num				US
01.025	Preset Reference 5	±VM_SPEED_FREQ_REF Hz		0.00 Hz	RW	Num				US
01.026	Preset Reference 6	±VM_SPEED_FREQ_REF Hz		0.00 Hz	RW	Num				US
01.027	Preset Reference 7	±VM_SPEED_FREQ_REF Hz		0.00 Hz	RW	Num				US
01.028	Preset Reference 8	±VM_SPEED_FREQ_REF Hz		0.00 Hz	RW	Num				US
01.029	Skip Reference 1	0.00 to VM_SPEED_FREQ_REF_UNIPOLAR Hz		0.00 Hz	RW	Num				US
01.030	Skip Reference Band 1	0.00 to 25.00 Hz		0.50 Hz	RW	Num				US
01.031	Skip Reference 2	0.00 to VM_SPEED_FREQ_REF_UNIPOLAR Hz		0.00 Hz	RW	Num				US
01.032	Skip Reference Band 2	0.00 to 25.00 Hz		0.50 Hz	RW	Num				US
01.033	Skip Reference 3	0.00 to VM_SPEED_FREQ_REF_UNIPOLAR Hz		0.00 Hz	RW	Num				US
01.034	Skip Reference Band 3	0.00 to 25.00 Hz		0.50 Hz	RW	Num				US
01.035	Reference In Rejection Zone	Off (0) or On (1)			RO	Bit	ND	NC	PT	
01.036	Analog Reference 1	±VM_SPEED_FREQ_USER_REFS Hz		0.00 Hz	RO	Num		NC		
01.038	Percentage Trim	±100.00 %		0.00 %	RW	Num		NC		
01.041	Reference Select Flag 1	Off (0) or On (1)		Off (0)	RW	Bit		NC		
01.042	Reference Select Flag 2	Off (0) or On (1)		Off (0)	RW	Bit		NC		
01.043	Reference Select Flag 3	Off (0) or On (1)		Off (0)	RW	Bit		NC		
01.045	Preset Select Flag 1	Off (0) or On (1)		Off (0)	RW	Bit		NC		
01.046	Preset Select Flag 2	Off (0) or On (1)		Off (0)	RW	Bit		NC		
01.047	Preset Select Flag 3	Off (0) or On (1)		Off (0)	RW	Bit		NC		
01.048	Preset Selector Timer Reset	Off (0) or On (1)		Off (0)	RW	Bit		NC		
01.049	Reference Selected Indicator	1 to 6			RO	Num	ND	NC	PT	
01.050	Preset Selected Indicator	1 to 8			RO	Num	ND	NC	PT	
01.051	Power-up Keypad Control Mode Reference	rESet (0), LAST (1), PrESet (2)		rESet (0)	RW	Txt				US
01.057	Force Reference Direction	None (0), For (1), rEv (2)		None (0)	RW	Txt				
01.069	Reference in rpm	±VM_SPEED_FREQ_REF rpm			RO	Num	ND	NC	PT	
01.070	Clamped Reference	±VM_SPEED_FREQ_REF Hz			RO	Num	ND	NC	PT	
01.071	Alternative Reference	±VM_SPEED_FREQ_REF Hz		0.00 Hz	RW	Num		NC	PT	
01.072	Alternative Reference Enable	Off (0) or On (1)			RO	Bit	ND	NC	PT	

RW	Read / Write	RO	Read only	Num	Number parameter	Bit	Bit parameter	Txt	Text string	Bin	Binary parameter	FI	Filtered
ND	No default value	NC	Not copied	PT	Protected parameter	RA	Rating dependent	US	User save	PS	Power-down save	DE	Destination
Date	Date parameter	Time	Time parameter										



## 10.2 Menu 2: Ramps

Figure 10-2 Menu 2 logic diagram

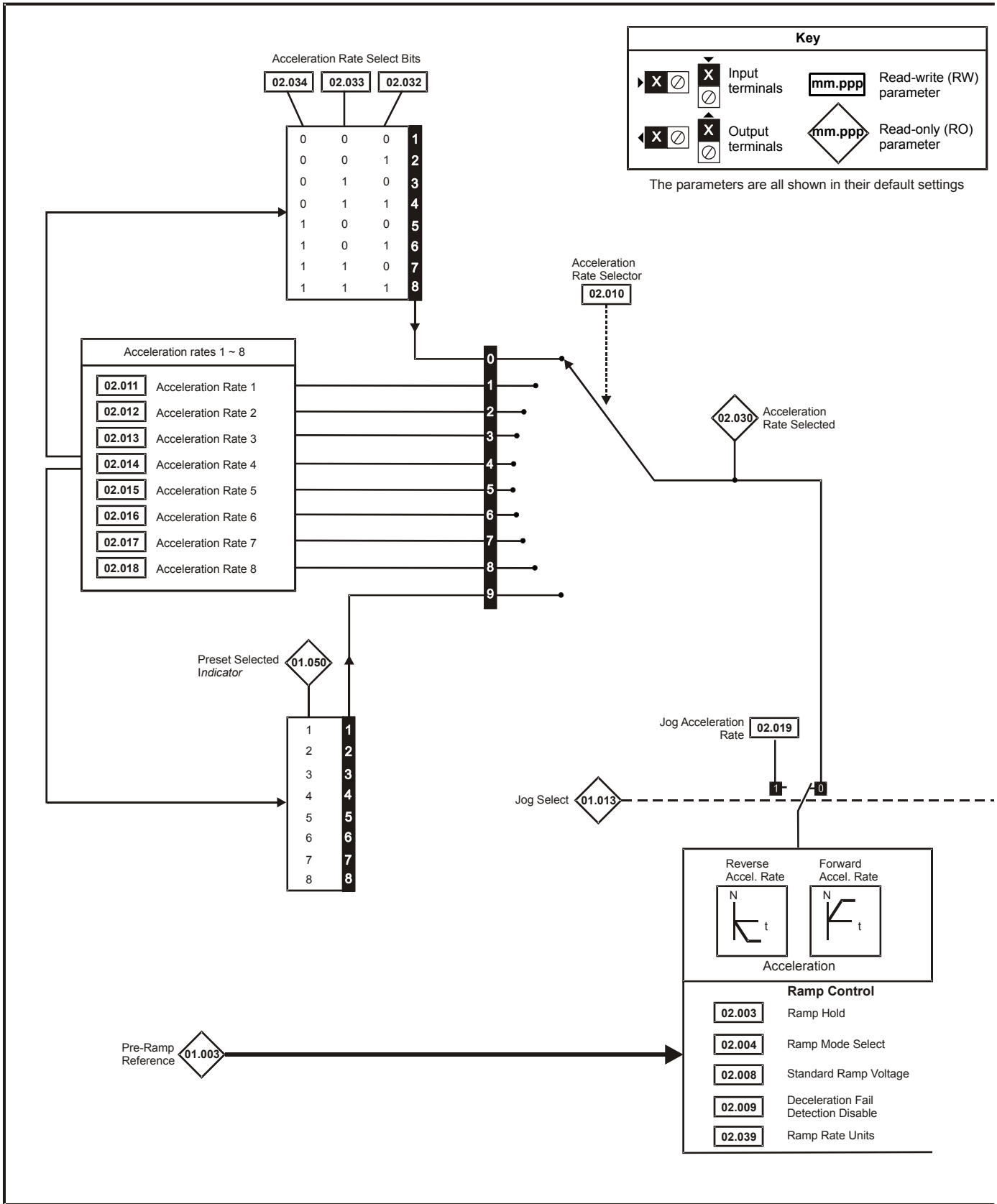



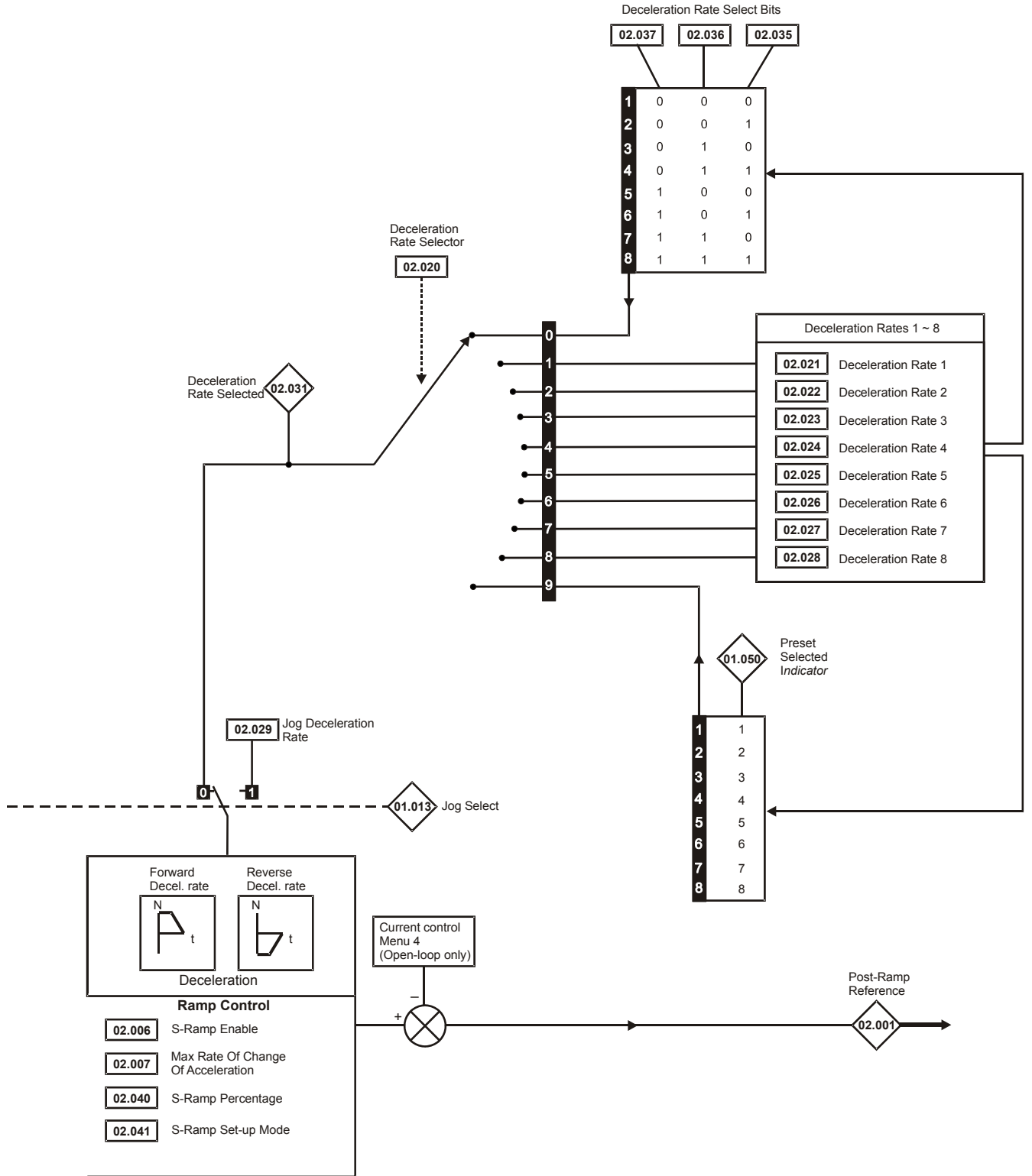

Parameter		Range (⇄)	Default (⇒)	Type				
		OL	OL	RO	Num	ND	NC	PT
02.001	Post Ramp Reference	±VM_SPEED_FREQ_REF Hz		RO	Num	ND	NC	PT
02.003	Ramp Hold	Off (0) or On (1)	Off (0)	RW	Bit			US
02.004	Ramp Mode Select	FASt (0), Std (1), Std.bSt (2), FSt.bSt (3)	Std (1)	RW	Txt			US
02.006	S Ramp Enable	Off (0) or On (1)	Off (0)	RW	Bit			US
02.007	Max Rate Of Change Of Acceleration	0.0 to 300.0 s <sup>2</sup> /100Hz	3.1 s <sup>2</sup> /100 Hz	RW	Num			US
02.008	Standard Ramp Voltage	±VM_DC_VOLTAGE_SET V	110 V drive: 375 V 200 V drive: 375 V 400 V drive 50 Hz: 750 V 400 V drive 60 Hz: 775 V 575 V drive: 895 V 690 V drive: 1075 V	RW	Num		RA	US
02.009	Deceleration Fail Detection Disable	Off (0) or On (1)	Off (0)	RW	Bit			US
02.010	Acceleration Rate Selector	0 to 9	0	RW	Num			US
02.011	Acceleration Rate 1	±VM_ACCEL_RATE s	5.0 s	RW	Num			US
02.012	Acceleration Rate 2	±VM_ACCEL_RATE s	5.0 s	RW	Num			US
02.013	Acceleration Rate 3	±VM_ACCEL_RATE s	5.0 s	RW	Num			US
02.014	Acceleration Rate 4	±VM_ACCEL_RATE s	5.0 s	RW	Num			US
02.015	Acceleration Rate 5	±VM_ACCEL_RATE s	5.0 s	RW	Num			US
02.016	Acceleration Rate 6	±VM_ACCEL_RATE s	5.0 s	RW	Num			US
02.017	Acceleration Rate 7	±VM_ACCEL_RATE s	5.0 s	RW	Num			US
02.018	Acceleration Rate 8	±VM_ACCEL_RATE s	5.0 s	RW	Num			US
02.019	Jog Acceleration Rate	±VM_ACCEL_RATE s	0.2 s	RW	Num			US
02.020	Deceleration Rate Selector	0 to 9	0	RW	Num			US
02.021	Deceleration Rate 1	±VM_ACCEL_RATE s	10.0 s	RW	Num			US
02.022	Deceleration Rate 2	±VM_ACCEL_RATE s	10.0 s	RW	Num			US
02.023	Deceleration Rate 3	±VM_ACCEL_RATE s	10.0 s	RW	Num			US
02.024	Deceleration Rate 4	±VM_ACCEL_RATE s	10.0 s	RW	Num			US
02.025	Deceleration Rate 5	±VM_ACCEL_RATE s	10.0 s	RW	Num			US
02.026	Deceleration Rate 6	±VM_ACCEL_RATE s	10.0 s	RW	Num			US
02.027	Deceleration Rate 7	±VM_ACCEL_RATE s	10.0 s	RW	Num			US
02.028	Deceleration Rate 8	±VM_ACCEL_RATE s	10.0 s	RW	Num			US
02.029	Jog Deceleration Rate	±VM_ACCEL_RATE s	0.2 s	RW	Num			US
02.030	Acceleration Rate Selected	0 to 8		RO	Num	ND	NC	PT
02.031	Deceleration Rate Selected	0 to 8		RO	Num	ND	NC	PT
02.032	Acceleration Rate Select Bit 0	Off (0) or On (1)	Off (0)	RW	Bit		NC	
02.033	Acceleration Rate Select Bit 1	Off (0) or On (1)	Off (0)	RW	Bit		NC	
02.034	Acceleration Rate Select Bit 2	Off (0) or On (1)	Off (0)	RW	Bit		NC	
02.035	Deceleration Rate Select Bit 0	Off (0) or On (1)	Off (0)	RW	Bit		NC	
02.036	Deceleration Rate Select Bit 1	Off (0) or On (1)	Off (0)	RW	Bit		NC	
02.037	Deceleration Rate Select Bit 2	Off (0) or On (1)	Off (0)	RW	Bit		NC	
02.039	Ramp Rate Units	0 to 1	0	RW	Num			US
02.040	S Ramp Percentage	0.0 to 50.0 %	0.0 %	RW	Num			US
02.041	S Ramp Set-up Mode	0 to 2	0	RW	Num			US
02.042	Maximum Rate Of Change Of Acceleration 1	0.0 to 300.0 s <sup>2</sup> /100 Hz	0.0 s <sup>2</sup> /100 Hz	RW	Num			US
02.043	Maximum Rate Of Change Of Acceleration 2	0.0 to 300.0 s <sup>2</sup> /100 Hz	0.0 s <sup>2</sup> /100 Hz	RW	Num			US
02.044	Maximum Rate Of Change Of Acceleration 3	0.0 to 300.0 s <sup>2</sup> /100 Hz	0.0 s <sup>2</sup> /100 Hz	RW	Num			US
02.045	Maximum Rate Of Change Of Acceleration 4	0.0 to 300.0 s <sup>2</sup> /100 Hz	0.0 s <sup>2</sup> /100 Hz	RW	Num			US

RW	Read / Write	RO	Read only	Num	Number parameter	Bit	Bit parameter	Txt	Text string	Bin	Binary parameter	FI	Filtered
ND	No default value	NC	Not copied	PT	Protected parameter	RA	Rating dependent	US	User save	PS	Power-down save	DE	Destination
Date	Date parameter	Time	Time parameter										

## 10.3 Menu 3: Frequency control

Figure 10-3 Menu 3 Open-loop logic diagram

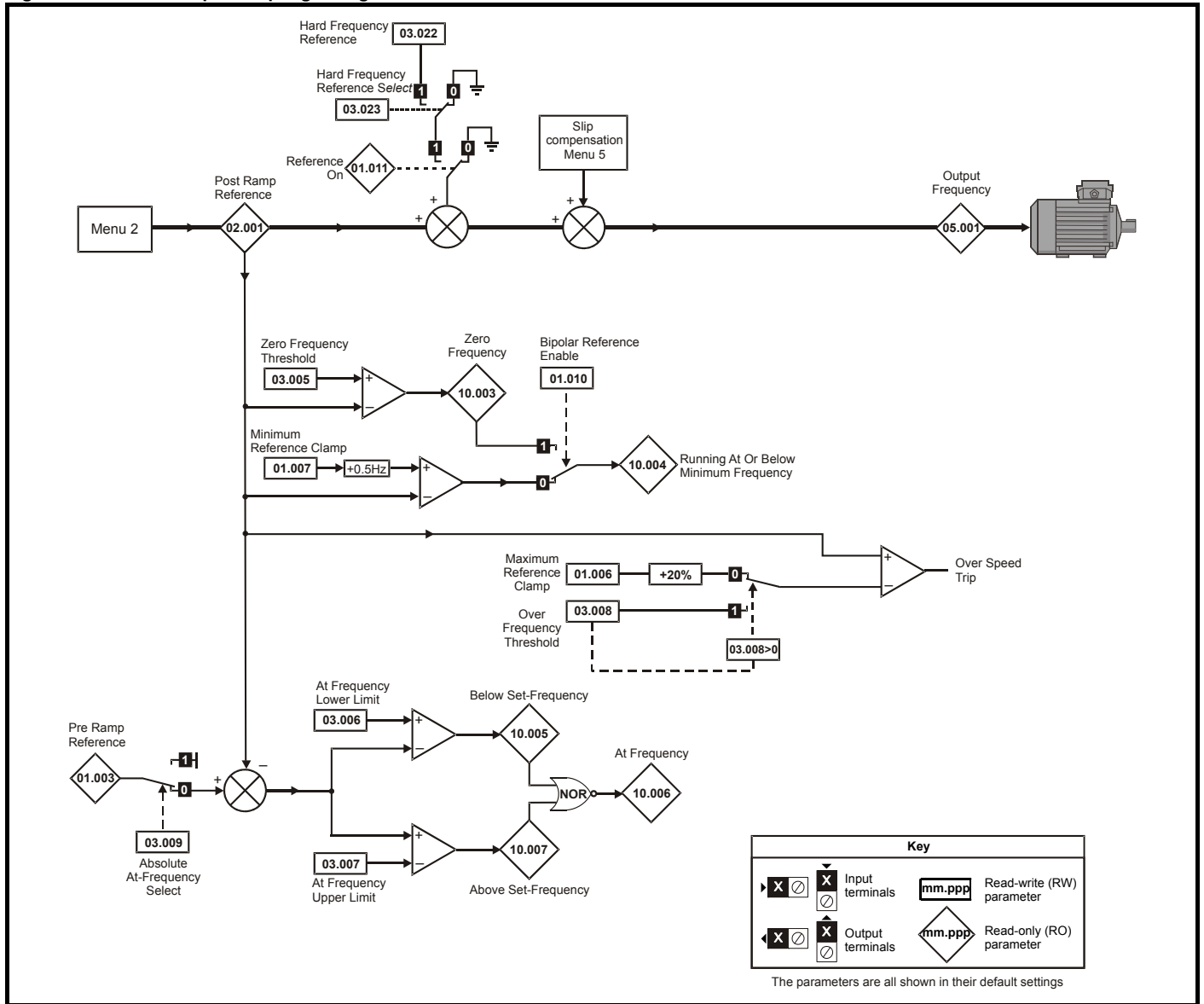

**Figure 10-4 Menu 3 Logic diagram**

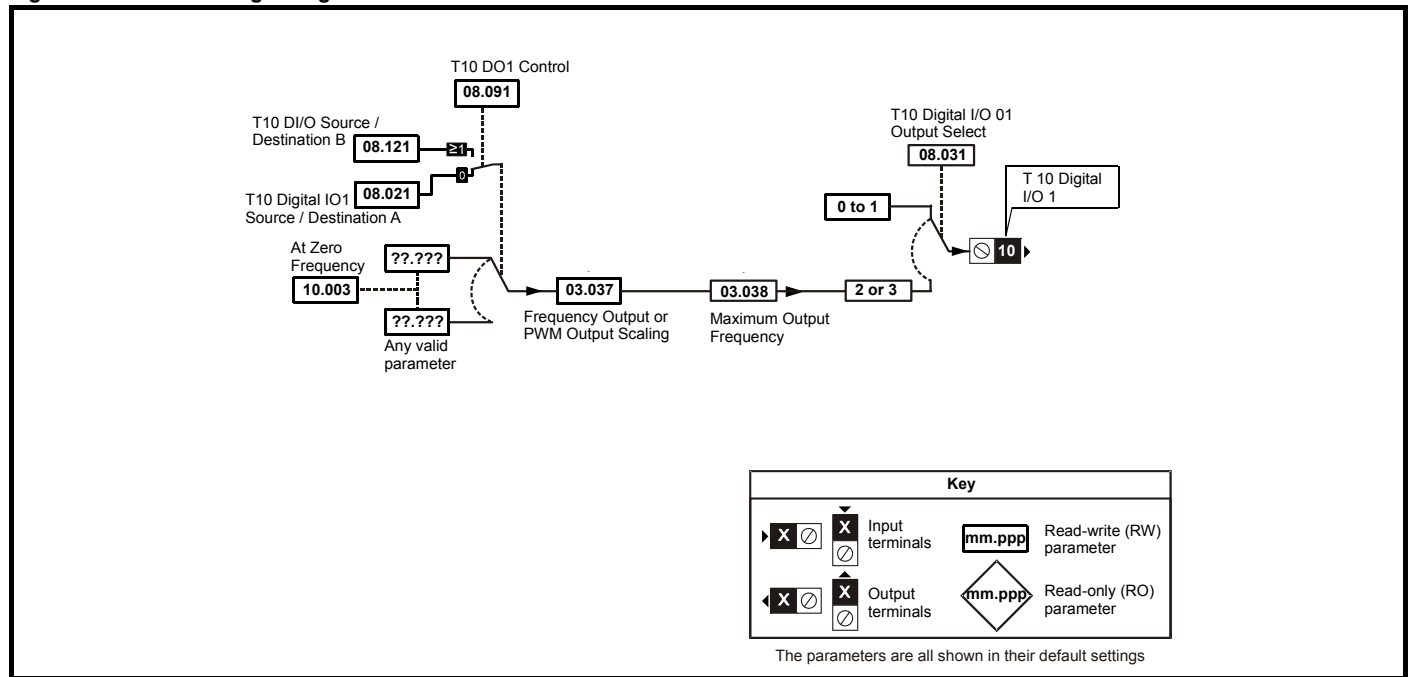

Parameter	Range (⇄)	Default (⇒)		Type					
		OL	OL						
<b>03.001</b> Final Demand Reference	±VM_FREQ Hz			RO	Num	ND	NC	PT	FI
<b>03.005</b> Zero Frequency Threshold	0.00 to 20.00 Hz		2.00 Hz	RW	Num				US
<b>03.006</b> At Frequency Lower Limit	0.00 to VM_SPEED_FREQ_REF_UNIPOLAR Hz		1.00 Hz	RW	Num				US
<b>03.007</b> At Frequency Upper Limit	0.00 to VM_SPEED_FREQ_REF_UNIPOLAR Hz		1.00 Hz	RW	Num				US
<b>03.008</b> Over Frequency Threshold	0.00 to VM_SPEED_FREQ_REF_UNIPOLAR Hz		0.00 Hz	RW	Num				US
<b>03.009</b> Absolute At Frequency Select	Off (0) or On (1)		Off (0)	RW	Bit				US
<b>03.022</b> Hard Frequency Reference	±VM_SPEED_FREQ_REF Hz		0.00 Hz	RW	Num				US
<b>03.023</b> Hard Frequency Reference Select	Off (0) or On (1)		Off (0)	RW	Bit				US
<b>03.037</b> Frequency Output or PWM Output Scaling (T10)	0.000 to 4.000		1.000	RW	Num				US
<b>03.038</b> Maximum Output Frequency (T10)	1 (0), 2 (1), 5 (2), 10 (3) kHz		5 (2) kHz	RW	Txt				US
<b>03.072</b> Motor Speed Percent	±150.0 %			RO		ND	NC	PT	FI

RW	Read / Write	RO	Read only	Num	Number parameter	Bit	Bit parameter	Txt	Text string	Bin	Binary parameter	FI	Filtered
ND	No default value	NC	Not copied	PT	Protected parameter	RA	Rating dependent	US	User save	PS	Power-down save	DE	Destination
Date	Date parameter	Time	Time parameter										

## 10.4 Menu 4: Torque and current control

Figure 10-5 Menu 4 Open loop logic diagram

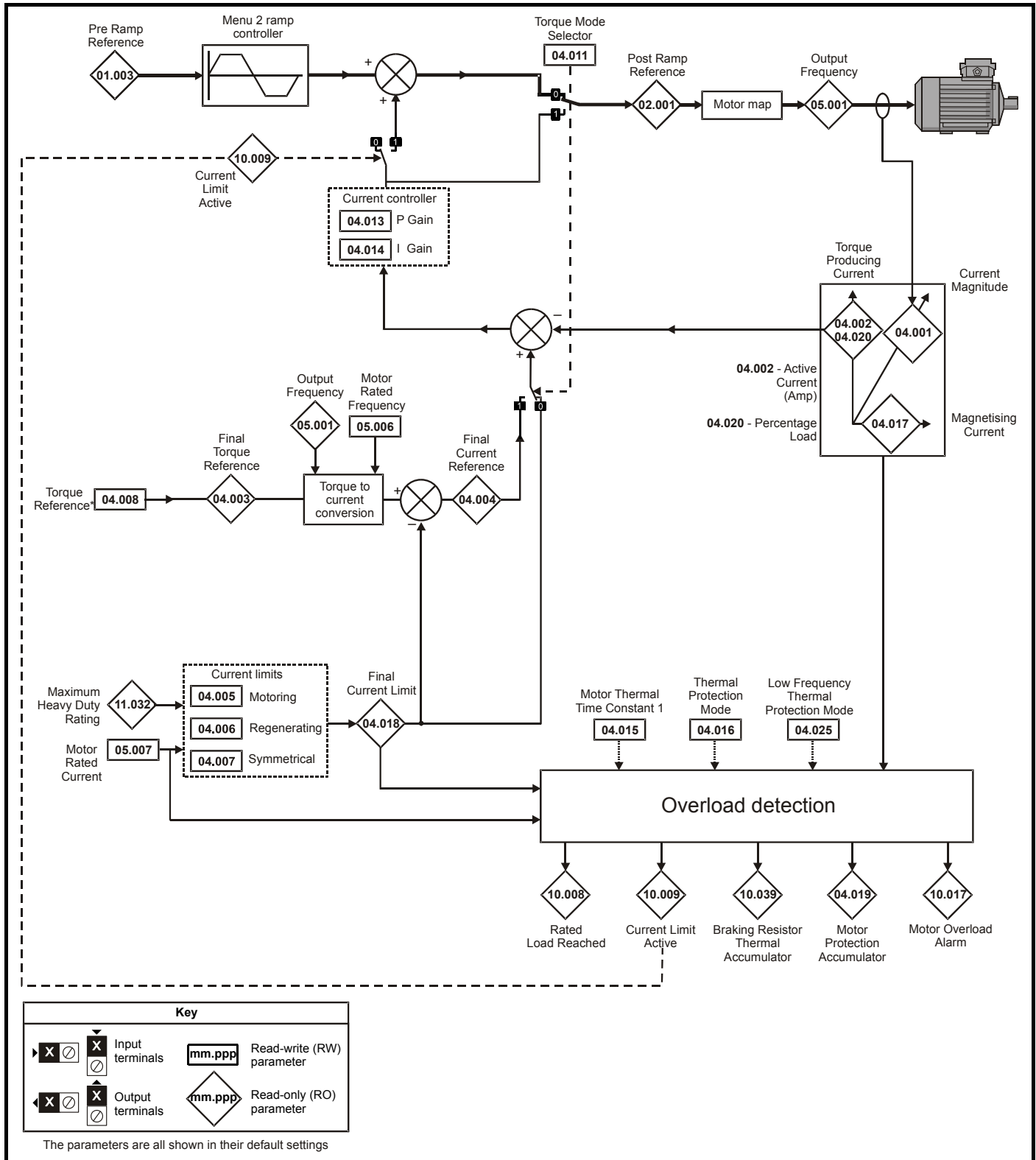

Parameter	Range (⇄)		Default (⇒)		Type							
	OL		OL									
04.001	Current Magnitude	±VM_DRIVE_CURRENT A				RO	Num	ND	NC	PT	FI	
04.002	Torque Producing Current	±VM_DRIVE_CURRENT A				RO	Num	ND	NC	PT	FI	
04.003	Final Torque Reference	±VM_TORQUE_CURRENT %				RO	Num	ND	NC	PT	FI	
04.004	Final Current Reference	±VM_TORQUE_CURRENT %				RO	Num	ND	NC	PT	FI	
04.005	Motoring Current Limit	±VM_MOTOR1_CURRENT_LIMIT %		165.0 %		RW	Num		RA		US	
04.006	Regenerating Current Limit	±VM_MOTOR1_CURRENT_LIMIT %		165.0 %		RW	Num		RA		US	
04.007	Symmetrical Current Limit	±VM_MOTOR1_CURRENT_LIMIT %		165.0 %		RW	Num		RA		US	
04.008	Torque Reference	±VM_USER_CURRENT %		0.0 %		RW	Num				US	
04.011	Torque Mode Selector	0 to 1		0		RW	Num				US	
04.013	Current Controller Kp Gain	0.00 to 4000.00		20.00		RW	Num				US	
04.014	Current Controller Ki Gain	0.000 to 600.000		40.000		RW	Num				US	
04.015	Motor Thermal Time Constant 1	1 to 3000 s		179 s		RW	Num				US	
04.016	Thermal Protection Mode	0 (0) to 3 (3)		0 (0)		RW	Bin				US	
04.017	Magnetising Current	±VM_DRIVE_CURRENT A				RO	Num	ND	NC	PT	FI	
04.018	Final Current Limit	±VM_TORQUE_CURRENT %				RO	Num	ND	NC	PT		
04.019	Motor Protection Accumulator	0.0 to 100.0 %				RO	Num	ND	NC	PT	PS	
04.020	Percentage Load	±VM_USER_CURRENT %				RO	Num	ND	NC	PT	FI	
04.024	User Current Maximum Scaling	±VM_TORQUE_CURRENT_UNIPOLAR %		165.0 %		RW	Num		RA		US	
04.025	Low Frequency Thermal Protection Mode	0 to 1		0		RW	Num				US	
04.026	Percentage Torque	±VM_USER_CURRENT %				RO	Num	ND	NC	PT	FI	
04.036	Motor Protection Accumulator Power-up Value	Pr.dn (0), 0 (1)		Pr.dn (0)		RW	Txt				US	
04.041	User Over Current Trip Level	0 to 100 %		100 %		RW	Num		RA		US	

RW	Read / Write	RO	Read only	Num	Number parameter	Bit	Bit parameter	Txt	Text string	Bin	Binary parameter	FI	Filtered
ND	No default value	NC	Not copied	PT	Protected parameter	RA	Rating dependent	US	User save	PS	Power-down save	DE	Destination
Date	Date parameter	Time	Time parameter										

## 10.5 Menu 5: Motor control

Figure 10-6 Menu 5 Open-loop logic diagram

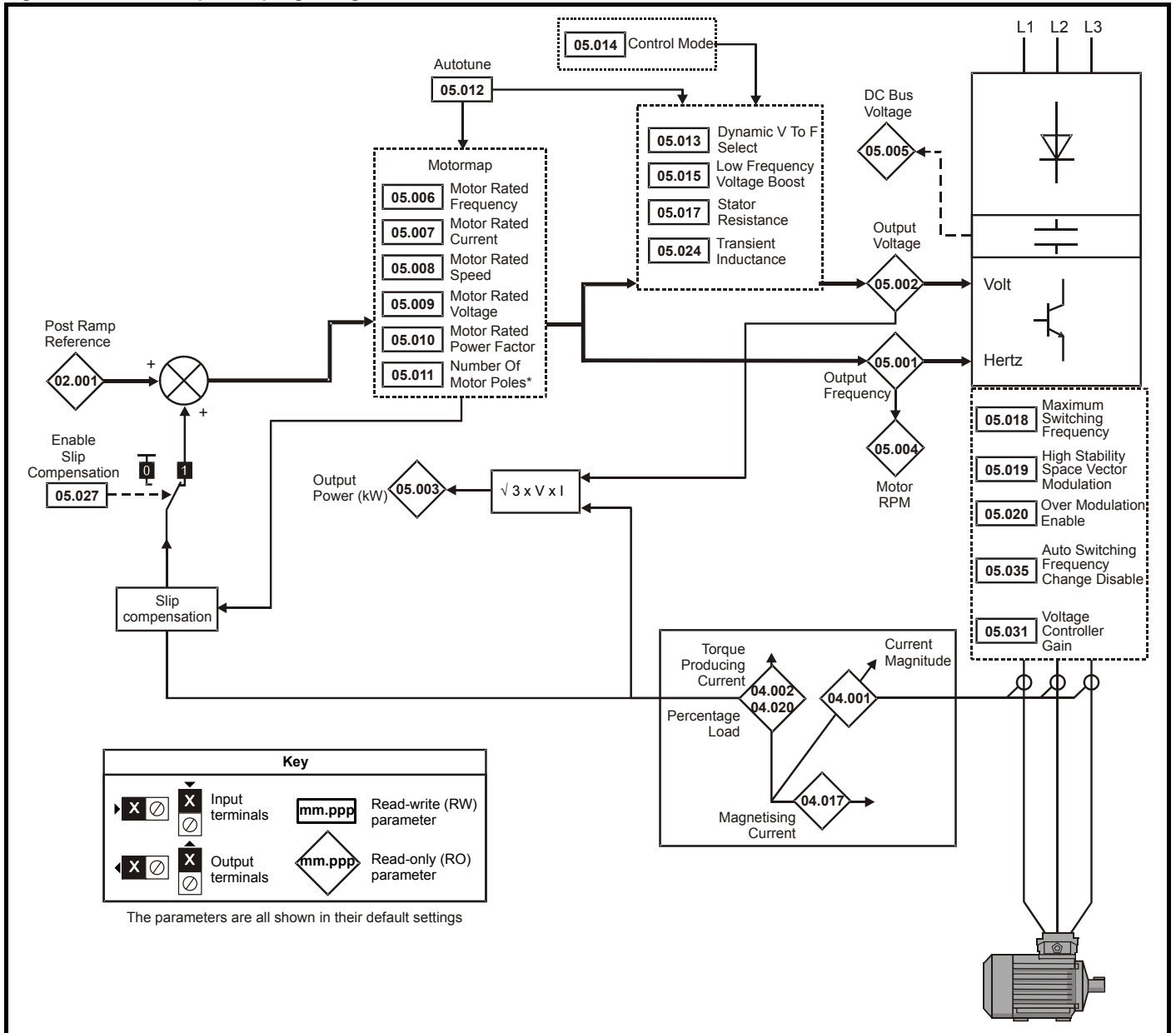

Parameter	Range (⊘)	Default (⇔)	Type					
	OL	OL						
05.001	Output Frequency	±VM_SPEED_FREQ_REF Hz	RO	Num	ND	NC	PT	FI
05.002	Output Voltage	±VM_AC_VOLTAGE V	RO	Num	ND	NC	PT	FI
05.003	Output Power	±VM_POWER kW	RO	Num	ND	NC	PT	FI
05.004	Motor Rpm	±80000 rpm	RO	Num	ND	NC	PT	FI
05.005	D.C. Bus Voltage	±VM_DC_VOLTAGE V	RO	Num	ND	NC	PT	FI
05.006	Motor Rated Frequency	0.00 to VM_SPEED_FREQ_REF_UNIPOLAR Hz	RW	Num		RA		US
05.007	Motor Rated Current	±VM_RATED_CURRENT A	RW	Num		RA		US
05.008	Motor Rated Speed	0.0 to 80000.0 rpm	RW	Num				US
05.009	Motor Rated Voltage	±VM_AC_VOLTAGE_SET V	RW	Num		RA		US
05.010	Motor Rated Power Factor	0.00 to 1.00	RW	Num		RA		US
05.011	Number Of Motor Poles	Auto (0) to 32 (16)	RW	Num				US
05.012	Autotune	0 to 2	RW	Num		NC		
05.013	Dynamic V To F Select	0 to 1	RW	Num				US
05.014	Control Mode	Ur.S (0), Ur (1), Fd (2), Ur.Auto (3), Ur.l (4), SrE (5)	RW	Txt				US
05.015	Low Frequency Voltage Boost	0.0 to 50.0 %	RW	Num				US
05.017	Stator Resistance	0.0000 to 99.9999 Ω	RW	Num		RA		US
05.018	Maximum Switching Frequency	0.667 (0), 1 (1), 2 (2), 3 (3), 4 (4), 6 (5), 8 (6), 12 (7), 16 (8) kHz	RW	Txt		RA		US
05.019	High Stability Space Vector Modulation	Off (0) or On (1)	RW	Bit				US
05.020	Over Modulation Enable	Off (0) or On (1)	RW	Bit				US
05.024	Transient Inductance	0.000 to 500.00 mH	RW	Num		RA		US
05.025	Stator Inductance	0.00 to 5000.00 mH	RW	Num		RA		US
05.027	Enable Slip Compensation	±150.0 %	RW	Num				US
05.031	Voltage Controller Gain	1 to 30	RW	Num				US
05.033	Slip Compensation Limit	0.00 to 10.00 Hz	RW	Num				US
05.035	Auto-switching Frequency Change Disable	0 to 2	RW	Num				US
05.036	Slip Compensation Filter	64 (0), 128 (1), 256 (2), 512 (3) ms	RW	Txt				US
05.037	Switching Frequency	0.667 (0), 1 (1), 2 (2), 3 (3), 4 (4), 6 (5), 8 (6), 12 (7), 16 (8) kHz	RO	Txt	ND	NC	PT	
05.040	Spin Start Boost	0.0 to 10.0	RW	Num				US
05.042	Reverse Output Phase Sequence	Off (0) or On (1)	RW	Bit				US
05.059	Maximum Deadtime Compensation	0.000 to 10.000 μs	RO	Num		NC	PT	US
05.060	Current At Maximum Deadtime Compensation	0.00 to 100.00 %	RO	Num		NC	PT	US
05.061	Disable Deadtime Compensation	Off (0) or On (1)	RW	Bit				US
05.074	Boost End Voltage	0.0 to 100.0 %	RW	Num				US
05.075	Boost End Frequency	0.0 to 100.0 %	RW	Num				US
05.076	Second Point Voltage	0.0 to 100.0 %	RW	Num				US
05.077	Second Point Frequency	0.0 to 100.0 %	RW	Num				US
05.078	Third point voltage	0.0 to 100.0 %	RW	Num				US
05.079	Third point frequency	0.0 to 100.0 %	RW	Num				US
05.080	Low acoustic noise enable	Off (0) or On (1)	RW	Bit				US
05.081	Change to maximum drive switching frequency at low output current	Off (0) or On (1)	RW	Bit				US
05.082	Motor Rated Power	±VM_POWER kW	RW	Num		RA		
05.083	Voltage Shelving Disable	Off (0) or On (1)	RW	Bit				US
05.084	Low Frequency Slip Boost	0.0 to 100.0 %	RW	Num				US

RW	Read / Write	RO	Read only	Num	Number parameter	Bit	Bit parameter	Txt	Text string	Bin	Binary parameter	FI	Filtered
ND	No default value	NC	Not copied	PT	Protected parameter	RA	Rating dependent	US	User save	PS	Power-down save	DE	Destination
Date	Date parameter	Time	Time parameter										



## 10.6 Menu 6: Sequencer and clock

Figure 10-7 Menu 6 logic diagram

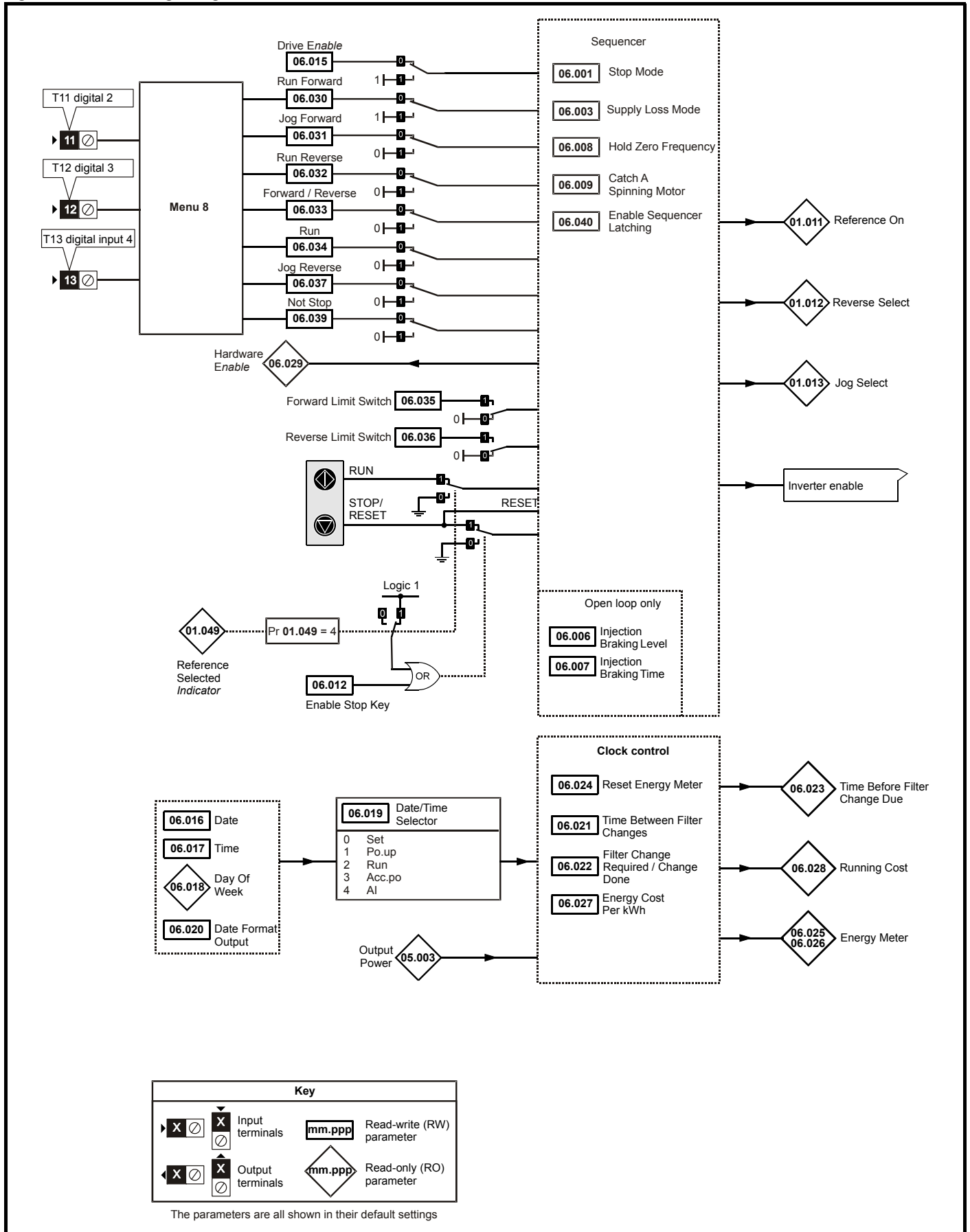

Parameter		Range (⊕)	Default(⇒)	Type						
		OL	OL							
06.001	Stop Mode	CoASt (0), rP (1), rP.dc I (2), dc I (3), td.dc I (4), diS (5), No.rP (6)	rP (1)	RW	Txt					US
06.002	Limit Switch Stop Mode	StoP (0) or rP (1),	rP (1)	RW	Txt					US
06.003	Supply Loss Mode	diS (0), rP.StoP (1), ridE.th (2)	diS (0)	RW	Txt					US
06.004	Start/Stop Logic Select	0 to 2	50 Hz: 0, 60 Hz: 4	RW	Num					US
06.006	Injection Braking Level	0.0 to 150.0 %	100.0 %	RW	Num		RA			US
06.007	Injection Braking Time	0.0 to 25.0 s	1.0 s	RW	Num					US
06.008	Hold Zero Frequency	Off (0) or On (1)	Off (0)	RW	Bit					US
06.009	Catch A Spinning Motor	diS (0), EnAbLE (1), Fr.OnLy (2), rv.OnLy (3)	diS (0)	RW	Txt					US
06.010	Enable Conditions	0 to 4087		RO	Bin	ND	NC	PT		
06.011	Sequencer State Machine Inputs	0 to 127		RO	Bin	ND	NC	PT		
06.012	Enable Stop Key	Off (0) or On (1)	Off (0)	RW	Bit					US
06.014	Disable Auto Reset On Enable	Off (0) or On (1)	Off (0)	RW	Bit					US
06.015	Drive Enable	Off (0) or On (1)	On (1)	RW	Bit		NC			US
06.016	Date	00-00-00 to 31-12-99		RW	Date	ND	NC	PT		
06.017	Time	00:00:00 to 23:59:59		RW	Time	ND	NC	PT		
06.018	Day Of Week	Sun (0), Non (1), tuE (2), UEd (3), thu (4), Fri (5), SAT (6)		RO	Txt	ND	NC	PT		
06.019	Date/Time Selector	SEt (0), Po.uP (1), run (2), Acc.Po (3), AI (4),	Po.uP (1)	RW	Txt					US
06.020	Date Format	Std (0), US (1)	Std (0)	RW	Txt					US
06.021	Time Between Filter Changes	0 to 30000 Hours	0 Hours	RW	Num					US
06.022	Filter Change Required / Change Done	Off (0) or On (1)		RW	Bit	ND	NC			
06.023	Time Before Filter Change Due	0 to 30000 Hours		RO	Num	ND	NC	PT	PS	
06.024	Reset Energy Meter	Off (0) or On (1)	Off (0)	RW	Bit					
06.025	Energy Meter: MWh	±999.9 MWh		RO	Num	ND	NC	PT	PS	
06.026	Energy Meter: kWh	±99.99 kWh		RO	Num	ND	NC	PT	PS	
06.027	Energy Cost Per kWh	0.0 to 600.0	0.0	RW	Num					US
06.028	Running Cost	±32000		RO	Num	ND	NC	PT		
06.029	Hardware Enable	Off (0) or On (1)	On (1)	RO	Bit		NC			
06.030	Run Forward	Off (0) or On (1)	Off (0)	RW	Bit		NC			
06.031	Jog Forward	Off (0) or On (1)	Off (0)	RW	Bit		NC			
06.032	Run Reverse	Off (0) or On (1)	Off (0)	RW	Bit		NC			
06.033	Forward/Reverse	Off (0) or On (1)	Off (0)	RW	Bit		NC			
06.034	Run	Off (0) or On (1)	Off (0)	RW	Bit		NC			
06.035	Forward Limit Switch	Off (0) or On (1)	Off (0)	RW	Bit		NC			
06.036	Reverse Limit Switch	Off (0) or On (1)	Off (0)	RW	Bit		NC			
06.037	Jog Reverse	Off (0) or On (1)	Off (0)	RW	Bit		NC			
06.038	User Enable	Off (0) or On (1)	Off (0)	RW	Bit		NC			
06.039	Not Stop	Off (0) or On (1)	Off (0)	RW	Bit		NC			
06.040	Enable Sequencer Latching	Off (0) or On (1)	Off (0)	RW	Bit					US
06.041	Drive Event Flags	0 to 3	0	RW	Bin		NC			
06.045	Cooling Fan control	0 to 5	2	RW	Num					US
06.046	Supply Loss Hold Disable	Off (0) or On (1)	Off (0)	RW	Bit					US
06.047	Input Phase Loss Detection Mode	FuLL (0), rIPPLE (1), diS (2)	FuLL (0)	RW	Txt					US
06.048	Supply Loss Detection Level	0 to VM_SUPPLY_LOSS_LEVEL V	110 V drive: 205 V 200 V drive: 205 V 400 V drive: 410 V 575 V drive: 540 V 690 V drive: 540 V	RW	Num		RA			US
06.051	Allow Motoring Load	Off (0) or On (1)	Off (0)	RW	Bit		NC			
06.052	Motor Pre-heat Current Magnitude	0 to 100 %	0 %	RW	Num					US
06.059	Output Phase Loss Detection Enable	Off (0) or On (1)	Off (0)	RW	Bit					US
06.060	Standby Mode Enable	Off (0) or On (1)	Off (0)	RW	Bit					US

Parameter		Range (↕)	Default(⇔)	Type						
		OL	OL							
<b>06.061</b>	Standby Mode Mask	0 to 3	0	RW	Bin					US
<b>06.071</b>	Slow Rectifier Charge Rate Enable	Off (0) or On (1)	Off (0)	RW	Bit					US
<b>06.073</b>	Braking IGBT Lower Threshold	0 to VM_DC_VOLTAGE_SET V	110 V drive: 390 V 200 V drive: 390 V 400 V drive: 780 V 575 V drive: 930 V 690 V drive: 1120 V	RW	Num					US
<b>06.074</b>	Braking IGBT Upper Threshold	0 to VM_DC_VOLTAGE_SET V	110 V drive: 390 V 200 V drive: 390 V 400 V drive: 780 V 575 V drive: 930 V 690 V drive: 1120 V	RW	Num					US
<b>06.075</b>	Low Voltage Braking IGBT Threshold	0 to VM_DC_VOLTAGE_SET V	0 V	RW	Num					US
<b>06.076</b>	Low Voltage Braking IGBT Threshold Select	Off (0) or On (1)	Off (0)	RW	Bit					
<b>06.077</b>	Low DC Link Operation	Off (0) or On (1)	Off (0)	RW	Bit					US
<b>06.089</b>	DC Injection Active	Off (0) or On (1)	Off (0)	RO	Bit			NC	PT	US

RW	Read / Write	RO	Read only	Num	Number parameter	Bit	Bit parameter	Txt	Text string	Bin	Binary parameter	FI	Filtered
ND	No default value	NC	Not copied	PT	Protected parameter	RA	Rating dependent	US	User save	PS	Power-down save	DE	Destination
Date	Date parameter	Time	Time parameter										

## 10.7 Menu 7: Analog I/O

Figure 10-8 Menu 7 logic diagram

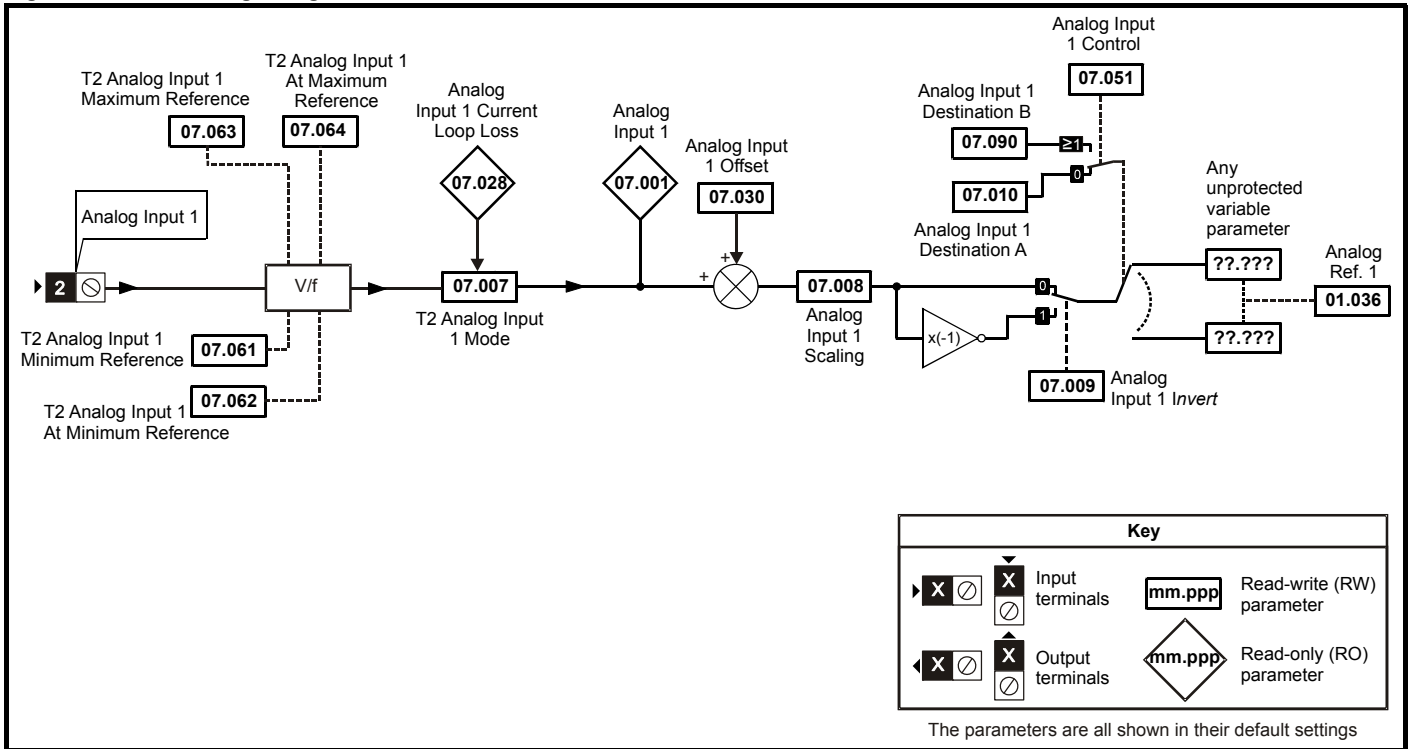

Parameter	Range (⊕)	Default(⇔)	Type						
			OL						
07.001	Analog Input 1 (T2)	±100.00 %		RO	Num	ND	NC	PT	FI
07.004	Stack Temperature	±250 °C		RO	Num	ND	NC	PT	
07.005	Auxiliary Temperature	±250 °C		RO	Num	ND	NC	PT	
07.007	Analog Input 1 Mode (T2)	4-20.S (-6), 20-4.S (-5), 4-20.L (-4), 20-4.L (-3), 4-20.H (-2), 20-4.H (-1), 0-20 (0), 20-0 (1), 4-20.tr (2), 20-4.tr (3), 4-20 (4), 20-4 (5), VoLt (6)	VoLt (6)	RW	Txt				US
07.008	Analog Input 1 Scaling (T2)	0.000 to 10.000	1.000	RW	Num				US
07.009	Analog Input 1 Invert (T2)	Off (0) or On (1)	Off (0)	RW	Bit				US
07.010	Analog Input 1 Destination A (T2)	0.000 to 30.999	1.036	RW	Num	DE		PT	US
07.026	Analog Input 1 Preset on Current Loss (T2)	4.00 to 20.00	4.00	RW	Num				US
07.028	Analog Input 1 Current Loop Loss (T2)	Off (0) or On (1)		RO	Bit	ND	NC	PT	
07.030	Analog Input 1 Offset (T2)	±100.00 %	0.00 %	RW	Num				US
07.034	Inverter Temperature	±250 °C		RO	Num	ND	NC	PT	
07.035	Percentage Of d.c. Link Thermal Trip Level	0 to 100 %		RO	Num	ND	NC	PT	
07.036	Percentage Of Drive Thermal Trip Level	0 to 100 %		RO	Num	ND	NC	PT	
07.037	Temperature Nearest To Trip Level	0 to 29999		RO	Num	ND	NC	PT	
07.051	Analog Input 1 Control (T2)	0 to 5	0	RW	Num				US
07.061	Analog Input 1 Minimum Reference (T2)	0.00 to 100.00 %	0.00 %	RW	Num				US
07.062	Analog Input 1 At Minimum Reference (T2)	±100.00 %	0.00 %	RW	Num				US
07.063	Analog Input 1 Maximum Reference (T2)	0.00 to 100.00 %	100.00 %	RW	Num				US
07.064	Analog Input 1 At Maximum Reference (T2)	±100.00 %	100.00 %	RW	Num				US
07.090	Analog Input 1 Destination B (T2)	0.000 to 30.999		RO	Num	DE		PT	US

RW	Read / Write	RO	Read only	Num	Number parameter	Bit	Bit parameter	Txt	Text string	Bin	Binary parameter	FI	Filtered
ND	No default value	NC	Not copied	PT	Protected parameter	RA	Rating dependent	US	User save	PS	Power-down save	DE	Destination
Date	Date parameter	Time	Time parameter										



## 10.8 Menu 8: Digital I/O

Figure 10-9 Menu 8 logic diagram

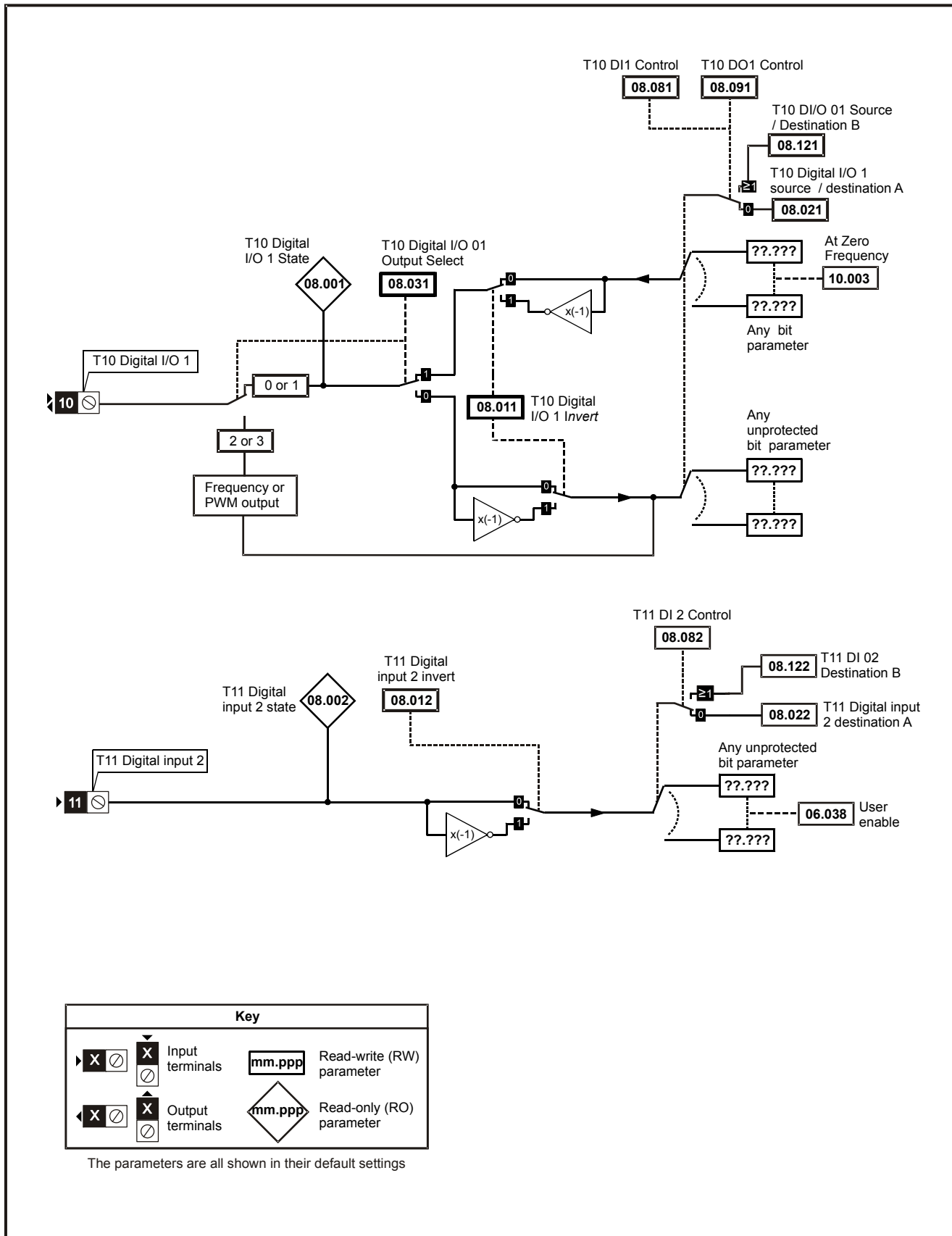

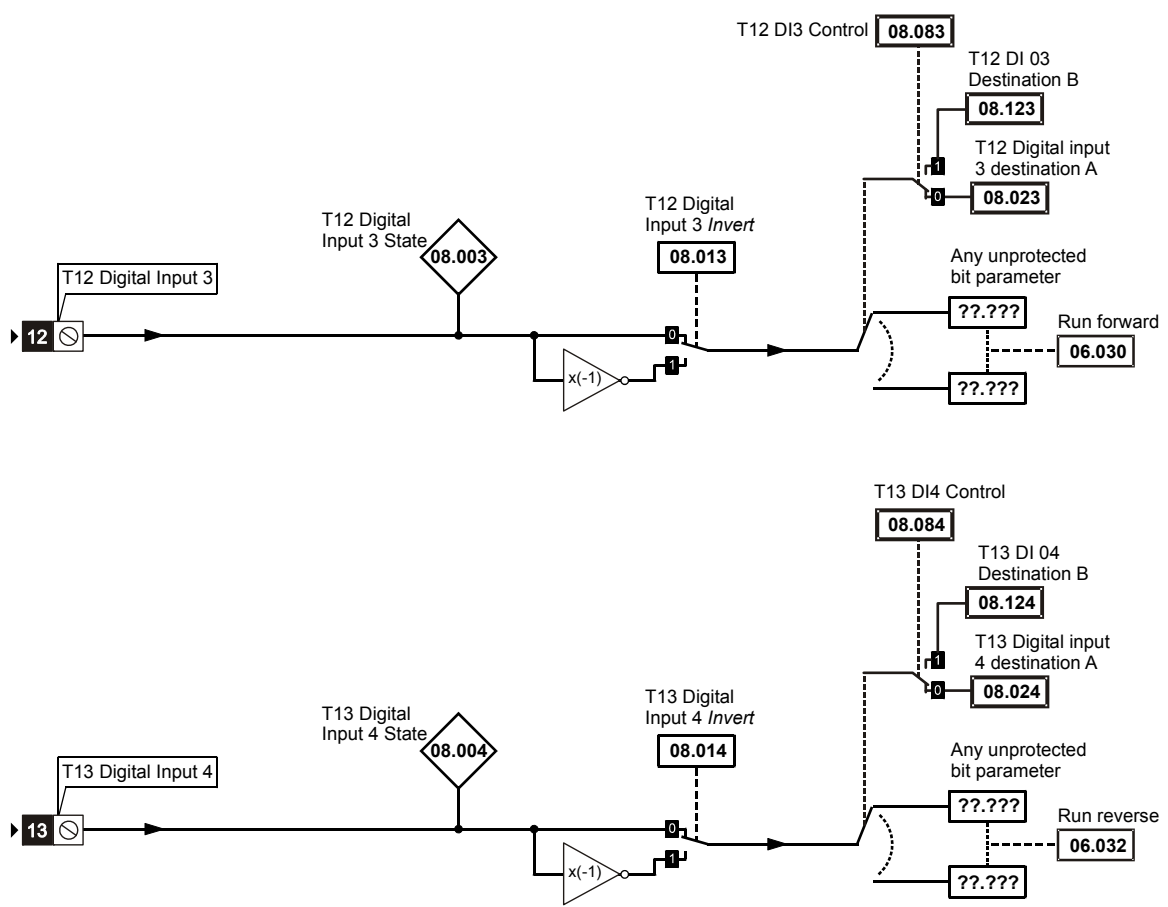
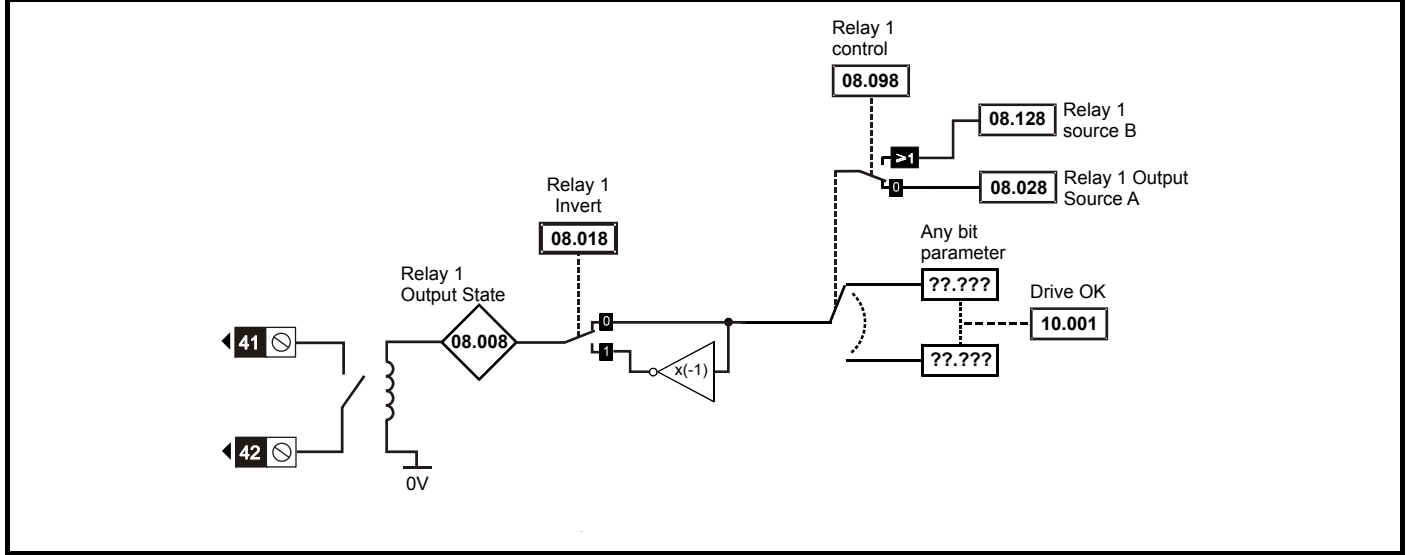

Figure 10-10 Menu 8 logic (cont)





Parameter		Range (⇄)	Default (⇒)	Type					
		OL	OL						
08.001	Digital I/O 1 State (T10)	Off (0) or On (1)		RO	Bit	ND	NC	PT	
08.002	Digital Input 2 State(T11)	Off (0) or On (1)		RO	Bit	ND	NC	PT	
08.003	Digital Input 3 State (T12)	Off (0) or On (1)		RO	Bit	ND	NC	PT	
08.004	Digital Input 4 State (T13)	Off (0) or On (1)		RO	Bit	ND	NC	PT	
08.008	Relay 1 Output State	Off (0) or On (1)		RO	Bit	ND	NC	PT	
08.011	Digital I/O 1 Invert (T10)	Not.Inv (0), InvErt (1)	Not.Inv (0)	RW	Txt				US
08.012	Digital Input 2 Invert (T11)	Not.Inv (0), InvErt (1)	Not.Inv (0)	RW	Txt				US
08.013	Digital Input 3 Invert (T12)	Not.Inv (0), InvErt (1)	Not.Inv (0)	RW	Txt				US
08.014	Digital Input 4 Invert (T13)	Not.Inv (0), InvErt (1)	Not.Inv (0)	RW	Txt				US
08.018	Relay 1 Invert	Not.Inv (0), InvErt (1)	Not.Inv (0)	RW	Txt				US
08.020	Digital I/O Read Word	0 to 2048		RO	Num	ND	NC	PT	
08.021	Digital IO1 Source / Destination A (T10)	0.000 to 30.999	10.003	RW	Num	DE		PT	US
08.022	Digital Input 2 Destination A (T11)	0.000 to 30.999	50 Hz: 6.038 60 Hz: 6.039	RW	Num	DE		PT	US
08.023	Digital Input 03 Destination A (T12)	0.000 to 30.999	6.030	RW	Num	DE		PT	US
08.024	Digital Input 04 Destination A (T13)	0.000 to 30.999	6.032	RW	Num	DE		PT	US
08.028	Relay 1 Output Source A	0.000 to 30.999	10.001	RW	Num			PT	US
08.031	Digital I/O 01 Output Select (T10)	InPut (0), OutPut (1), Fr (2), PuLSE (3)	OutPut (1)	RW	Txt				US
08.043	24 V Supply Input State	Off (0) or On (1)		RO	Bit	ND	NC	PT	
08.053	24 V Supply Invert	Not.Inv (0), InvErt (1)	Not.Inv (0)	RW	Txt				US
08.063	24 V Supply Input Destination	0.000 to 30.999	0.000	RW	Num	DE		PT	US
08.081	DI1 Control (T10)	0 to 21	0	RW	Num				US
08.082	DI2 Control (T11)	0 to 21	0	RW	Num				US
08.083	DI3 Control (T12)	0 to 21	0	RW	Num				US
08.084	DI4 Control (T13)	0 to 21	0	RW	Num				US
08.091	DO1 Control	0 to 20	0	RW	Num				US
08.098	Relay 1 Control	0 to 20	0	RW	Num				US
08.121	DI/O 01 Source / Destination B (T10)	0.000 to 30.999		RO	Num	DE		PT	US
08.122	Digital Input 2 Destination B (T11)	0.000 to 30.999		RO	Num	DE		PT	US
08.123	DI 03 Destination B (T12)	0.000 to 30.999		RO	Num	DE		PT	US
08.124	DI 04 Destination B (T13)	0.000 to 30.999		RO	Num	DE		PT	US
08.128	Relay 01 Source B	0.000 to 30.999	0.000	RW	Num			PT	US

RW	Read / Write	RO	Read only	Num	Number parameter	Bit	Bit parameter	Txt	Text string	Bin	Binary parameter	FI	Filtered
ND	No default value	NC	Not copied	PT	Protected parameter	RA	Rating dependent	US	User save	PS	Power-down save	DE	Destination
Date	Date parameter	Time	Time parameter										

## 10.9 Menu 10: Status and trips

Parameter	Range (⇅)	Default (⇔)	Type				
	OL	OL					
10.001	Drive OK	Off (0) or On (1)	RO	Bit	ND	NC	PT
10.002	Drive Active	Off (0) or On (1)	RO	Bit	ND	NC	PT
10.003	Zero Frequency	Off (0) or On (1)	RO	Bit	ND	NC	PT
10.004	Running At or Below Minimum Frequency	Off (0) or On (1)	RO	Bit	ND	NC	PT
10.005	Below Set Frequency	Off (0) or On (1)	RO	Bit	ND	NC	PT
10.006	At Frequency	Off (0) or On (1)	RO	Bit	ND	NC	PT
10.007	Above Set Frequency	Off (0) or On (1)	RO	Bit	ND	NC	PT
10.008	Rated Load Reached	Off (0) or On (1)	RO	Bit	ND	NC	PT
10.009	Current Limit Active	Off (0) or On (1)	RO	Bit	ND	NC	PT
10.010	Regenerating	Off (0) or On (1)	RO	Bit	ND	NC	PT
10.011	Braking IGBT Active	Off (0) or On (1)	RO	Bit	ND	NC	PT
10.012	Braking Resistor Alarm	Off (0) or On (1)	RO	Bit	ND	NC	PT
10.013	Reverse Direction Commanded	Off (0) or On (1)	RO	Bit	ND	NC	PT
10.014	Reverse Direction Running	Off (0) or On (1)	RO	Bit	ND	NC	PT
10.015	Supply Loss	Off (0) or On (1)	RO	Bit	ND	NC	PT
10.016	Under Voltage Active	Off (0) or On (1)	RO	Bit	ND	NC	PT
10.017	Motor Overload Alarm	Off (0) or On (1)	RO	Bit	ND	NC	PT
10.018	Drive Over-temperature Alarm	Off (0) or On (1)	RO	Bit	ND	NC	PT
10.019	Drive Warning	Off (0) or On (1)	RO	Bit	ND	NC	PT
10.020	Trip 0	0 to 255	RO	Txt	ND	NC	PT PS
10.021	Trip 1	0 to 255	RO	Txt	ND	NC	PT PS
10.022	Trip 2	0 to 255	RO	Txt	ND	NC	PT PS
10.023	Trip 3	0 to 255	RO	Txt	ND	NC	PT PS
10.024	Trip 4	0 to 255	RO	Txt	ND	NC	PT PS
10.025	Trip 5	0 to 255	RO	Txt	ND	NC	PT PS
10.026	Trip 6	0 to 255	RO	Txt	ND	NC	PT PS
10.027	Trip 7	0 to 255	RO	Txt	ND	NC	PT PS
10.028	Trip 8	0 to 255	RO	Txt	ND	NC	PT PS
10.029	Trip 9	0 to 255	RO	Txt	ND	NC	PT PS
10.030	Braking Resistor Rated Power	0.0 to 99999.9 kW	RW	Num			US
10.031	Braking Resistor Thermal Time Constant	0.00 to 1500.00 s	RW	Num			US
10.032	External Trip	Off (0) or On (1)	RW	Bit		NC	
10.033	Drive Reset	Off (0) or On (1)	RW	Bit		NC	
10.034	Number Of Auto-reset Attempts	NonE (0), 1 (1), 2 (2), 3 (3), 4 (4), 5 (5),inF (6)	RW	Txt			US
10.035	Auto-reset Delay	0.0 to 600.0 s	RW	Num			US
10.036	Auto-reset Hold Drive Healthy	Off (0) or On (1)	RW	Bit			US
10.037	Action On Trip Detection	0 to 31	RW	Num			US
10.038	User Trip	0 to 255	RW	Num	ND	NC	
10.039	Braking Resistor Thermal Accumulator	0.0 to 100.0 %	RO	Num	ND	NC	PT
10.040	Status Word	0 to 32767	RO	Num	ND	NC	PT
10.041	Trip 0 Date	00-00-00 to 31-12-99	RO	Date	ND	NC	PT PS
10.042	Trip 0 Time	00:00:00 to 23:59:59	RO	Time	ND	NC	PT PS
10.043	Trip 1 Date	00-00-00 to 31-12-99	RO	Date	ND	NC	PT PS
10.044	Trip 1 Time	00:00:00 to 23:59:59	RO	Time	ND	NC	PT PS
10.045	Trip 2 Date	00-00-00 to 31-12-99	RO	Date	ND	NC	PT PS
10.046	Trip 2 Time	00:00:00 to 23:59:59	RO	Time	ND	NC	PT PS
10.047	Trip 3 Date	00-00-00 to 31-12-99	RO	Date	ND	NC	PT PS
10.048	Trip 3 Time	00:00:00 to 23:59:59	RO	Time	ND	NC	PT PS
10.049	Trip 4 Date	00-00-00 to 31-12-99	RO	Date	ND	NC	PT PS
10.050	Trip 4 Time	00:00:00 to 23:59:59	RO	Time	ND	NC	PT PS
10.051	Trip 5 Date	00-00-00 to 31-12-99	RO	Date	ND	NC	PT PS

Parameter		Range (⇅)	Default (⇔)	Type						
		OL	OL							
10.052	Trip 5 Time	00:00:00 to 23:59:59		RO	Time	ND	NC	PT	PS	
10.053	Trip 6 Date	00-00-00 to 31-12-99		RO	Date	ND	NC	PT	PS	
10.054	Trip 6 Time	00:00:00 to 23:59:59		RO	Time	ND	NC	PT	PS	
10.055	Trip 7 Date	00-00-00 to 31-12-99		RO	Date	ND	NC	PT	PS	
10.056	Trip 7 Time	00:00:00 to 23:59:59		RO	Time	ND	NC	PT	PS	
10.057	Trip 8 Date	00-00-00 to 31-12-99		RO	Date	ND	NC	PT	PS	
10.058	Trip 8 Time	00:00:00 to 23:59:59		RO	Time	ND	NC	PT	PS	
10.059	Trip 9 Date	00-00-00 to 31-12-99		RO	Date	ND	NC	PT	PS	
10.060	Trip 9 Time	00:00:00 to 23:59:59		RO	Time	ND	NC	PT	PS	
10.061	Braking Resistor Resistance	0.00 to 10000.00 Ω	0.00 Ω	RW	Num					US
10.065	Autotune Active	Off (0) or On (1)		RO	Bit	ND	NC	PT		
10.066	Limit Switch Active	Off (0) or On (1)		RO	Bit	ND	NC	PT		
10.069	Additional Status Bits	0 to 65535		RO	Num	ND	NC	PT		
10.070	Trip 0 Sub-trip Number	0 to 65535		RO	Num	ND	NC	PT	PS	
10.071	Trip 1 Sub-trip Number	0 to 65535		RO	Num	ND	NC	PT	PS	
10.072	Trip 2 Sub-trip Number	0 to 65535		RO	Num	ND	NC	PT	PS	
10.073	Trip 3 Sub-trip Number	0 to 65535		RO	Num	ND	NC	PT	PS	
10.074	Trip 4 Sub-trip Number	0 to 65535		RO	Num	ND	NC	PT	PS	
10.075	Trip 5 Sub-trip Number	0 to 65535		RO	Num	ND	NC	PT	PS	
10.076	Trip 6 Sub-trip Number	0 to 65535		RO	Num	ND	NC	PT	PS	
10.077	Trip 7 Sub-trip Number	0 to 65535		RO	Num	ND	NC	PT	PS	
10.078	Trip 8 Sub-trip Number	0 to 65535		RO	Num	ND	NC	PT	PS	
10.079	Trip 9 Sub-trip Number	0 to 65535		RO	Num	ND	NC	PT	PS	
10.080	Stop Motor	Off (0) or On (1)		RO	Bit	ND	NC	PT		
10.081	Phase Loss	Off (0) or On (1)		RO	Bit	ND	NC	PT		
10.090	Drive Ready	Off (0) or On (1)		RO	Bit	ND	NC	PT		
10.101	Drive Status	Inh (0), rdy (1), StoP (2), ScAn (3), run (4), S.LoSS (5), rES (6), dc.inJ (7), rES (8), Error (9), ActivE (10), rES (11), rES (12), rES (13), HEAt (14), UU (15)		RO	Txt	ND	NC	PT		
10.102	Trip Reset Source	0 to 1023		RO	Num	ND	NC	PT	PS	
10.103	Trip Time Identifier	-2147483648 to 2147483647 ms		RO	Num	ND	NC	PT		
10.104	Active Alarm	NonE (0), br.rES (1), OV.Ld (2), rES (3), d.OV.Ld (4), tuning (5), LS (6), rES (7), rES (8), rES (9), rES (10), rES (11), rES(12), Lo.AC (13), I.AC.Lt (14)		RO	Txt	ND	NC	PT		
10.106	Potential Drive Damage Conditions	0 to 3		RO	Bin	ND	NC	PT	PS	
10.107	Low AC Alarm	Off (0) or On (1)		RO	Bit	ND	NC	PT		
10.108	Reversed cooling fan detected	Off (0) or On (1)		RO	Bit	ND		PT		

RW	Read / Write	RO	Read only	Num	Number parameter	Bit	Bit parameter	Txt	Text string	Bin	Binary parameter	FI	Filtered
ND	No default value	NC	Not copied	PT	Protected parameter	RA	Rating dependent	US	User save	PS	Power-down save	DE	Destination
Date	Date parameter	Time	Time parameter										

## 10.10 Menu 11: General drive set-up

Parameter	Range (⇅)		Default (⇒)		Type					
	OL		OL							
11.018	Status Mode Parameter 1	0.000 to 30.999	2.001		RW	Num			PT	US
11.019	Status Mode Parameter 2	0.000 to 30.999	4.020		RW	Num			PT	US
11.021	Customer Defined Scaling	0.000 to 10.000	1.000		RW	Num				US
11.022	Parameter Displayed At Power-up	0.000 to 0.080	0.010		RW	Num			PT	US
11.028	Drive Derivative	0 to 255			RO	Num	ND	NC	PT	
11.029	Software Version	00.00.00 to 99.99.99			RO	Ver	ND	NC	PT	
11.030	User Security Code	0 to 9999			RW	Num	ND	NC	PT	US
11.031	User Drive Mode	OPEn.LP (1)			RW	Txt	ND	NC	PT	US
11.032	Maximum Heavy Duty Rating	0.00 to 9999.99 A			RO	Num	ND	NC	PT	
11.033	Drive Rated Voltage	110V (0), 200V (1), 400V (2), 575V (3), 690V (4)			RO	Txt	ND	NC	PT	
11.034	Drive Configuration	AV (0), AI (1), AV.Pr (2), AI.Pr (3), PrESet (4), PAd (5), PAd.rEF (6), torque (8)	AV (0)		RW	Txt			PT	US
11.035	Power Software Version	00.00.00 to 99.99.99			RO	Ver	ND	NC	PT	
11.036	NV Media Card File Previously Loaded	0 to 999	0		RO	Num		NC	PT	
11.037	NV Media Card File Number	0 to 999	0		RW	Num				
11.038	NV Media Card File Type	NonE (0), OPEn.LP (1)			RO	Txt	ND	NC	PT	
11.039	NV Media Card File Version	0 to 9999			RO	Num	ND	NC	PT	
11.042	Parameter Cloning	NonE (0), rEAd (1), Prog (2), Auto (3), boot (4)	NonE (0)		RW	Txt		NC		US
11.043	Load Defaults	NonE (0), Std (1), US (2)	NonE (0)		RW	Txt		NC		
11.044	User Security Status	LEVEL.0 (0), ALL (1), r.onLy.0 (2), r.onLy.A (3), StAtUS (4), no.Acc (5)	LEVEL.0 (0)		RW	Txt	ND		PT	
11.046	Defaults Previously Loaded	0 to 2000			RO	Num	ND	NC	PT	US
11.052	Serial Number LS	0 to 999999			RO	Num	ND	NC	PT	
11.053	Serial Number MS	0 to 999999			RO	Num	ND	NC	PT	
11.054	Drive Date Code	0 to 9999			RO	Num	ND	NC	PT	
11.060	Maximum Rated Current	0.000 to 999.999 A			RO	Num	ND	NC	PT	
11.061	Full Scale Current Kc	0.000 to 999.999 A			RO	Num	ND	NC	PT	
11.063	Product Type	0 to 255			RO	Num	ND	NC	PT	
11.064	Product Identifier Characters	100 (1295069232) to □□□□ (2147483647)			RO	Chr	ND	NC	PT	
11.065	Frame size and voltage code	0 to 999			RO	Num	ND	NC	PT	
11.066	Power Stage Identifier	0 to 255			RO	Num	ND	NC	PT	
11.067	Control Board Identifier	0 to 255			RO	Num	ND	NC	PT	
11.068	Drive current rating	0 to 32767			RO	Num	ND	NC	PT	
11.070	Core Parameter Database Version	0.00 to 99.99			RO	Num	ND	NC	PT	
11.072	NV Media Card Create Special File	0 to 1	0		RW	Num		NC		
11.073	NV Media Card Type	NonE(0), rES(1), Sd.CArD(2)			RO	Num	ND	NC	PT	
11.075	NV Media Card Read-only Flag	Off (0) or On (1)			RO	Bit	ND	NC	PT	
11.076	NV Media Card Warning Suppression Flag	Off (0) or On (1)			RO	Bit	ND	NC	PT	
11.077	NV Media Card File Required Version	0 to 9999			RW	Num	ND	NC	PT	
11.079	Drive Name Characters 1-4	□□□□ (-2147483648) to □□□□ (2147483647)	---- (757935405)		RW	Chr			PT	US
11.080	Drive Name Characters 5-8	□□□□ (-2147483648) to □□□□ (2147483647)	---- (757935405)		RW	Chr			PT	US
11.081	Drive Name Characters 9-12	□□□□ (-2147483648) to □□□□ (2147483647)	---- (757935405)		RW	Chr			PT	US
11.082	Drive Name Characters 13-16	□□□□ (-2147483648) to □□□□ (2147483647)	---- (757935405)		RW	Chr			PT	US
11.084	Drive Mode	OPEn.LP (1)			RO	Txt	ND	NC	PT	
11.085	Security Status	NonE (0), r.onLy.A (1), StAtUS (2), no.Acc (3)			RO	Txt	ND	NC	PT	PS
11.086	Menu Access Status	LEVEL.0 (0), ALL (1)			RO	Txt	ND	NC	PT	PS
11.091	Additional Identifier Characters 1	□□□□ (-2147483648) to □□□□ (2147483647)			RO	Chr	ND	NC	PT	
11.092	Additional Identifier Characters 2	□□□□ (-2147483648) to □□□□ (2147483647)			RO	Chr	ND	NC	PT	
11.093	Additional Identifier Characters 3	□□□□ (-2147483648) to □□□□ (2147483647)			RO	Chr	ND	NC	PT	
11.094	Disable String Mode	Off (0) or On (1)	Off (0)		RW	Bit			PT	US
11.097	AI ID Code	NonE (0), Sd.CArD (1)			RO	Txt	ND	NC	PT	

RW	Read / Write	RO	Read only	Num	Number parameter	Bit	Bit parameter	Txt	Text string	Bin	Binary parameter	FI	Filtered
ND	No default value	NC	Not copied	PT	Protected parameter	RA	Rating dependent	US	User save	PS	Power-down save	DE	Destination
Date	Date parameter	Time	Time parameter										

## 10.11 Menu 22: Additional Menu 0 set-up

Parameter	Range(φ)	Default(⇔)	Type						
			OL	OL					
22.001	Parameter 00.001 Set-up	0.000 to 30.999	1.007	RW	Num			PT	US
22.002	Parameter 00.002 Set-up	0.000 to 30.999	1.006	RW	Num			PT	US
22.003	Parameter 00.003 Set-up	0.000 to 30.999	2.011	RW	Num			PT	US
22.004	Parameter 00.004 Set-up	0.000 to 30.999	2.021	RW	Num			PT	US
22.005	Parameter 00.005 Set-up	0.000 to 30.999	11.034	RW	Num			PT	US
22.006	Parameter 00.006 Set-up	0.000 to 30.999	5.007	RW	Num			PT	US
22.007	Parameter 00.007 Set-up	0.000 to 30.999	5.008	RW	Num			PT	US
22.008	Parameter 00.008 Set-up	0.000 to 30.999	5.009	RW	Num			PT	US
22.009	Parameter 00.009 Set-up	0.000 to 30.999	5.010	RW	Num			PT	US
22.010	Parameter 00.010 Set-up	0.000 to 30.999	11.044	RW	Num			PT	US
22.011	Parameter 00.011 Set-up	0.000 to 30.999	0.000	RW	Num			PT	US
22.012	Parameter 00.012 Set-up	0.000 to 30.999	0.000	RW	Num			PT	US
22.013	Parameter 00.013 Set-up	0.000 to 30.999	0.000	RW	Num			PT	US
22.014	Parameter 00.014 Set-up	0.000 to 30.999	0.000	RW	Num			PT	US
22.015	Parameter 00.015 Set-up	0.000 to 30.999	1.005	RW	Num			PT	US
22.016	Parameter 00.016 Set-up	0.000 to 30.999	7.007	RW	Num			PT	US
22.017	Parameter 00.017 Set-up	0.000 to 30.999	1.010	RW	Num			PT	US
22.018	Parameter 00.018 Set-up	0.000 to 30.999	1.021	RW	Num			PT	US
22.019	Parameter 00.019 Set-up	0.000 to 30.999	0.000	RW	Num			PT	US
22.020	Parameter 00.020 Set-up	0.000 to 30.999	0.000	RW	Num			PT	US
22.021	Parameter 00.021 Set-up	0.000 to 30.999	0.000	RW	Num			PT	US
22.022	Parameter 00.022 Set-up	0.000 to 30.999	0.000	RW	Num			PT	US
22.023	Parameter 00.023 Set-up	0.000 to 30.999	0.000	RW	Num			PT	US
22.024	Parameter 00.024 Set-up	0.000 to 30.999	0.000	RW	Num			PT	US
22.025	Parameter 00.025 Set-up	0.000 to 30.999	11.030	RW	Num			PT	US
22.026	Parameter 00.026 Set-up	0.000 to 30.999	0.000	RW	Num			PT	US
22.027	Parameter 00.027 Set-up	0.000 to 30.999	1.051	RW	Num			PT	US
22.028	Parameter 00.028 Set-up	0.000 to 30.999	2.004	RW	Num			PT	US
22.029	Parameter 00.029 Set-up	0.000 to 30.999	0.000	RW	Num			PT	US
22.030	Parameter 00.030 Set-up	0.000 to 30.999	11.042	RW	Num			PT	US
22.031	Parameter 00.031 Set-up	0.000 to 30.999	6.001	RW	Num			PT	US
22.032	Parameter 00.032 Set-up	0.000 to 30.999	5.013	RW	Num			PT	US
22.033	Parameter 00.033 Set-up	0.000 to 30.999	6.009	RW	Num			PT	US
22.034	Parameter 00.034 Set-up	0.000 to 30.999	0.000	RW	Num			PT	US
22.035	Parameter 00.035 Set-up	0.000 to 30.999	8.091	RW	Num			PT	US
22.036	Parameter 00.036 Set-up	0.000 to 30.999	0.000	RW	Num			PT	US
22.037	Parameter 00.037 Set-up	0.000 to 30.999	5.018	RW	Num			PT	US
22.038	Parameter 00.038 Set-up	0.000 to 30.999	5.012	RW	Num			PT	US
22.039	Parameter 00.039 Set-up	0.000 to 30.999	5.006	RW	Num			PT	US
22.040	Parameter 00.040 Set-up	0.000 to 30.999	5.011	RW	Num			PT	US
22.041	Parameter 00.041 Set-up	0.000 to 30.999	5.014	RW	Num			PT	US
22.042	Parameter 00.042 Set-up	0.000 to 30.999	5.015	RW	Num			PT	US
22.043	Parameter 00.043 Set-up	0.000 to 30.999	0.000	RW	Num			PT	US
22.044	Parameter 00.044 Set-up	0.000 to 30.999	0.000	RW	Num			PT	US
22.045	Parameter 00.045 Set-up	0.000 to 30.999	0.000	RW	Num			PT	US
22.046	Parameter 00.046 Set-up	0.000 to 30.999	0.000	RW	Num			PT	US
22.047	Parameter 00.047 Set-up	0.000 to 30.999	0.000	RW	Num			PT	US
22.048	Parameter 00.048 Set-up	0.000 to 30.999	0.000	RW	Num			PT	US
22.049	Parameter 00.049 Set-up	0.000 to 30.999	0.000	RW	Num			PT	US
22.050	Parameter 00.050 Set-up	0.000 to 30.999	0.000	RW	Num			PT	US
22.051	Parameter 00.051 Set-up	0.000 to 30.999	0.000	RW	Num			PT	US
22.052	Parameter 00.052 Set-up	0.000 to 30.999	0.000	RW	Num			PT	US
22.053	Parameter 00.053 Set-up	0.000 to 30.999	0.000	RW	Num			PT	US
22.054	Parameter 00.054 Set-up	0.000 to 30.999	0.000	RW	Num			PT	US

Parameter	Range(φ)	Default(⇔)	Type					
			OL		OL		OL	
22.055	Parameter 00.055 Set-up	0.000 to 30.999	RW	Num			PT	US
22.056	Parameter 00.056 Set-up	0.000 to 30.999	RW	Num			PT	US
22.057	Parameter 00.057 Set-up	0.000 to 30.999	RW	Num			PT	US
22.058	Parameter 00.058 Set-up	0.000 to 30.999	RW	Num			PT	US
22.059	Parameter 00.059 Set-up	0.000 to 30.999	RW	Num			PT	US
22.060	Parameter 00.060 Set-up	0.000 to 30.999	RW	Num			PT	US
22.061	Parameter 00.061 Set-up	0.000 to 30.999	RW	Num			PT	US
22.062	Parameter 00.062 Set-up	0.000 to 30.999	RW	Num			PT	US
22.063	Parameter 00.063 Set-up	0.000 to 30.999	RW	Num			PT	US
22.064	Parameter 00.064 Set-up	0.000 to 30.999	RW	Num			PT	US
22.065	Parameter 00.065 Set-up	0.000 to 30.999	RW	Num			PT	US
22.066	Parameter 00.066 Set-up	0.000 to 30.999	RW	Num			PT	US
22.067	Parameter 00.067 Set-up	0.000 to 30.999	RW	Num			PT	US
22.068	Parameter 00.068 Set-up	0.000 to 30.999	RW	Num			PT	US
22.069	Parameter 00.069 Set-up	0.000 to 30.999	RW	Num			PT	US
22.070	Parameter 00.070 Set-up	0.000 to 30.999	RW	Num			PT	US
22.071	Parameter 00.071 Set-up	0.000 to 30.999	RW	Num			PT	US
22.072	Parameter 00.072 Set-up	0.000 to 30.999	RW	Num			PT	US
22.073	Parameter 00.073 Set-up	0.000 to 30.999	RW	Num			PT	US
22.074	Parameter 00.074 Set-up	0.000 to 30.999	RW	Num			PT	US
22.075	Parameter 00.075 Set-up	0.000 to 30.999	RW	Num			PT	US
22.076	Parameter 00.076 Set-up	0.000 to 30.999	RW	Num			PT	US
22.077	Parameter 00.077 Set-up	0.000 to 30.999	RW	Num			PT	US
22.078	Parameter 00.078 Set-up	0.000 to 30.999	RW	Num			PT	US
22.079	Parameter 00.079 Set-up	0.000 to 30.999	RW	Num			PT	US
22.080	Parameter 00.080 Set-up	0.000 to 30.999	RW	Num			PT	US

RW	Read / Write	RO	Read only	Num	Number parameter	Bit	Bit parameter	Txt	Text string	Bin	Binary parameter	FI	Filtered
ND	No default value	NC	Not copied	PT	Protected parameter	RA	Rating dependent	US	User save	PS	Power-down save	DE	Destination
Date	Date parameter	Time	Time parameter										

# 11 Technical data

## 11.1 Drive technical data

### 11.1.1 Power and current ratings (Derating for switching frequency and temperature)

For a full explanation of 'Heavy Duty' refer to section 2.2 *Ratings* on page 10.

Table 11-1 Maximum permissible continuous output current @ 40 °C (104 °F) ambient

Model	Heavy Duty										
	Nominal rating		Maximum permissible continuous output current (A) for the following switching frequencies								
	kW	hp	0.667 kHz	1 kHz	2 kHz	3 kHz	4 kHz	6 kHz	8 kHz	12 kHz	16 kHz
<b>100 V</b>											
01100017	0.25	0.33									
01100024	0.37	0.5									
02100042	0.75	1.0	4.2	4.2	4.2	4.2	4.2	4.2	4.2	4.2	4.2
02100056	1.1	1.5	5.6	5.6	5.6	5.6	5.6	5.6	5.6	5.6	5.6
<b>200 V</b>											
01200017	0.25	0.33									
01200024	0.37	0.5									
01200033	0.55	0.75									
01200042	0.75	1.0									
02200024	0.37	0.5				2.4					
02200033	0.55	0.75				3.3					
02200042	0.75	1.0				4.2					
02200056	1.1	1.5	5.6	5.6	5.6	5.6	5.6	5.6	5.6	5.6	5.6
02200075	1.5	2.0	7.5	7.5	7.5	7.5	7.5	7.5	7.5	7.5	7.0
03200100	2.2	3.0	10	10	10	10	10	10	10	9	7.3
04200133	3.0	3.0									
04200176	4.0	5.0									
<b>400 V</b>											
02400013	0.37	0.5	1.3	1.3	1.3	1.3	1.3	1.3	1.3	1.3	
02400018	0.55	0.75	1.8	1.8	1.8	1.8	1.8	1.8	1.8	1.8	
02400023	0.75	1.0	2.3	2.3	2.3	2.3	2.3	2.3	2.3	2.0	
02400032	1.1	1.5	3.2	3.2	3.2	3.2	3.2	3.2	3.2	2.0	
02400041	1.5	2.0	4.1	4.1	4.1	4.1	4.1	4.1	3.8	2.0	
03400056	2.2	3.0	5.6	5.6	5.6	5.6	5.6	5.6	5.1	3.7	2.4
03400073	3.0	3.0	7.3	7.3	7.3	7.3	7.3	7.1	5.6	3.8	
03400094	4.0	5.0	9.4	9.4	9.4	9.4	9.4	8.5	7	4.6	
04400135	5.5	7.5									
04400170	7.5	10.0									

**Table 11-2 Maximum permissible continuous output current @ 50 °C (122 °F)**

Model	Heavy Duty								
	Maximum permissible continuous output current (A) for the following switching frequencies								
	0.667 kHz	1 kHz	2 kHz	3 kHz	4 kHz	6 kHz	8 kHz	12 kHz	16 kHz
<b>100 V</b>									
01100017									
01100024									
02100042	4.2	4.2	4.2	4.2	4.2	4.2	4.2	4.2	4.2
02100056	5.6	5.6	5.6	5.6	5.6	5.5	5.3	5.1	4.9
<b>200 V</b>									
01200017									
01200024									
01200033									
01200042									
02200024				2.4					
02200033				3.3					
02200042				4.2					
02200056	5.6	5.6	5.6	5.6	5.6	5.6	5.6	5.6	5.4
02200075	7.5	7.5	7.4	7.2	6.8	6.6	6.3	5.8	5.4
03200100	10	10	10	10	9.5	8.6	7.5	6.1	5
04200133									
04200176									
<b>400 V</b>									
02400013	1.3	1.3	1.3	1.3	1.3	1.3	1.3	1.1	
02400018	1.8	1.8	1.8	1.8	1.8	1.8	1.8	1.1	
02400023	2.3	2.3	2.3	2.3	2.3	2.3	2.3	1.1	
02400032	3.2	3.2	3.2	3.2	3.2	3.2	2.5	1.1	
02400041	4.1	4.1	4.1	4.1	3.7	3.2	2.5	1.1	
03400056	5.6	5.6	5.6	5.6	5	3.5	2.8	1.9	
03400073	7.3	7.3	7.3	7.3	6.2	4.5	3.4		
03400094	9.4	9.4	9.4	9.4	7.9	6.2	4.7		
04400135									
04400170									



### 11.1.2 Power dissipation

Table 11-3 Losses @ 40°C (104°F) ambient

Model	Heavy Duty										
	Nominal rating		Drive losses (w) taking into account any current derating for the given conditions								
	kW	hp	0.667 kHz	1 kHz	2 kHz	3 kHz	4 kHz	6 kHz	8 kHz	12 kHz	16 kHz
<b>100 V</b>											
01100017	0.25	0.33									
01100024	0.37	0.5									
02100042	0.75	1.0									
02100056	1.1	1.5									
<b>200 V</b>											
01200017	0.25	0.33									
01200024	0.37	0.5									
01200033	0.55	0.75									
01200042	0.75	1.0									
02200024	0.37	0.5									
02200033	0.55	0.75									
02200042	0.75	1.0									
02200056	1.1	1.5									
02200075	1.5	2.0									
03200100	2.2	3.0	85	87	91	96	101	110	117	121	117
04200133	3.0	3.0									
04200176	4.0	5.0									
<b>400 V</b>											
02400013	0.37	0.5									
02400018	0.55	0.75									
02400023	0.75	1.0									
02400032	1.1	1.5									
02400041	1.5	2.0									
03400056	2.2	3.0	55	57	62	68	75	86	90	86	77
03400073	3.0	3.0	72	74	82	90	98	113	101	92	
03400094	4.0	5.0	95	99	108	116	129	128	125	113	
04400135	5.5	7.5									
04400170	7.5	10.0									

**Table 11-4 Losses @ 50°C (122°F) ambient**

Model	Heavy Duty										
	Nominal rating		Drive losses (w) taking into account any current derating for the given conditions								
	kW	hp	0.667 kHz	1 kHz	2 kHz	3 kHz	4 kHz	6 kHz	8 kHz	12 kHz	16 kHz
<b>100 V</b>											
01100017	0.25	0.33									
01100024	0.37	0.5									
02100042	0.75	1.0									
02100056	1.1	1.5									
<b>200 V</b>											
01200017	0.25	0.33									
01200024	0.37	0.5									
01200033	0.55	0.75									
01200042	0.75	1.0									
02200024	0.37	0.5									
02200033	0.55	0.75									
02200042	0.75	1.0									
02200056	1.1	1.5									
02200075	1.5	2.0									
03200100	2.2	3.0	86	88	92	96	96	97	93	90	86
04200133	3.0	3.0									
04200176	4.0	5.0									
<b>400 V</b>											
02400013	0.37	0.5									
02400018	0.55	0.75									
02400023	0.75	1.0									
02400032	1.1	1.5									
02400041	1.5	2.0									
03400056	2.2	3.0	57	58	64	70	73	63	60	60	
03400073	3.0	3.0	73	75	82	91	87	77	71		
03400094	4.0	5.0	96	98	109	122	111	104	97		
04400135	5.5	7.5									
04400170	7.5	10.0									

### 11.1.3 Supply requirements

AC supply voltage:

- 100 V drive: 100 V to 120 V  $\pm 10\%$
- 200 V drive: 200 V to 240 V  $\pm 10\%$
- 400 V drive: 380 V to 480 V  $\pm 10\%$

Number of phases: 3

Maximum supply imbalance: 2 % negative phase sequence (equivalent to 3 % voltage imbalance between phases).

Frequency range: 48 to 62 Hz

For UL compliance only, the maximum supply symmetrical fault current must be limited to 100 kA

### 11.1.4 Line reactors

Input line reactors reduce the risk of damage to the drive resulting from poor phase balance or severe disturbances on the supply network.

Where line reactors are to be used, reactance values of approximately 2 % are recommended. Higher values may be used if necessary, but may result in a loss of drive output (reduced torque at high speed) because of the voltage drop.

For all drive ratings, 2 % line reactors permit drives to be used with a supply unbalance of up to 3.5 % negative phase sequence (equivalent to 5 % voltage imbalance between phases).

Severe disturbances may be caused by the following factors, for example:

- Power factor correction equipment connected close to the drive.
- Large DC drives having no or inadequate line reactors connected to the supply.
- Across the line (DOL) started motor(s) connected to the supply such that when any of these motors are started, the voltage dip exceeds 20 %

Such disturbances may cause excessive peak currents to flow in the input power circuit of the drive. This may cause nuisance tripping, or in extreme cases, failure of the drive.

Drives of low power rating may also be susceptible to disturbance when connected to supplies with a high rated capacity.

Line reactors are particularly recommended for use with the following drive models when one of the above factors exists, or when the supply capacity exceeds 175 kVA:

Model sizes 04200133 to 04400170 have an internal DC choke so they do not require AC line reactors except for cases of excessive phase unbalance or extreme supply conditions.

Where required, each drive must have its own reactor(s). Three individual reactors or a single three-phase reactor should be used.

### Reactor current ratings

The current rating of the line reactors should be as follows:

Continuous current rating:

Not less than the continuous input current rating of the drive

Repetitive peak current rating:

Not less than twice the continuous input current rating of the drive

### 11.1.5 Motor requirements

No. of phases: 3

Maximum voltage:

- 100 V drive: 240 V
- 200 V drive: 240 V
- 400 V drive: 480 V
- 575 V drive: 575 V
- 690 V drive: 690 V

### 11.1.6 Temperature, humidity and cooling method

Ambient temperature operating range:

- 20 °C to 40 °C (- 4 °F to 104 °F).

Output current derating must be applied at ambient temperatures >40 °C (104 °F).

Cooling method: Forced convection

Maximum humidity: 95 % non-condensing at 40 °C (104 °F)

### 11.1.7 Storage

-40 °C (-40 °F) to +60 °C (140 °F) for long term storage.

Storage time is 2 years.

Electrolytic capacitors in any electronic product have a storage period after which they require reforming or replacing.

The DC bus capacitors have a storage period of 10 years.

The low voltage capacitors on the control supplies typically have a storage period of 2 years and are thus the limiting factor.

Low voltage capacitors cannot be reformed due to their location in the circuit and thus may require replacing if the drive is stored for a period of 2 years or greater without power being applied.

It is therefore recommended that drives are powered up for a minimum of 1 hour after every 2 years of storage.

This process allows the drive to be stored for a further 2 years.

### 11.1.8 Altitude

Altitude range: 0 to 3,000 m (9,900 ft), subject to the following conditions:

1,000 m to 3,000 m (3,300 ft to 9,900 ft) above sea level: de-rate the maximum output current from the specified figure by 1% per 100 m (330 ft) above 1,000 m (3,300 ft)

For example at 3,000 m (9,900 ft) the output current of the drive would have to be de-rated by 20 %.

### 11.1.9 IP / UL Rating

The drive is rated to IP20 pollution degree 2 (dry, non-conductive contamination only).

In addition to this, drive sizes 2 and 3 are rated to IP21 standard (without an Adaptor Interface module installed).

The IP rating of a product is a measure of protection against ingress and contact to foreign bodies and water. It is stated as IP XX, where the two digits (XX) indicate the degree of protection provided as shown in Table 11-5.

**Table 11-5 IP Rating degrees of protection**

First digit		Second digit	
Protection against contact and ingress of foreign bodies		Protection against ingress of water	
0	No protection	0	No protection
1	Protection against large foreign bodies $\phi > 50$ mm (large area contact with the hand)	1	Protection against vertically falling drops of water
2	Protection against medium size foreign bodies $\phi > 12$ mm (finger)	2	Protection against spraywater (up to 15 ° from the vertical)
3	Protection against small foreign bodies $\phi > 2.5$ mm (tools, wires)	3	Protection against spraywater (up to 60 ° from the vertical)
4	Protection against granular foreign bodies $\phi > 1$ mm (tools, wires)	4	Protection against splashwater (from all directions)
5	Protection against dust deposit, complete protection against accidental contact.	5	Protection against heavy splash water (from all directions, at high pressure)
6	Protection against dust ingress, complete protection against accidental contact.	6	Protection against deckwater (e.g. in heavy seas)
7	-	7	Protection against immersion
8	-	8	Protection against submersion

**Table 11-6 UL enclosure ratings**

UL rating	Description
Type 1	Enclosures are intended for indoor use, primarily to provide a degree of protection against limited amounts of falling dirt.
Type 12	Enclosures are intended for indoor use, primarily to provide a degree of protection against dust, falling dirt and dripping non-corrosive liquids.

### 11.1.10 Corrosive gasses

Concentrations of corrosive gases must not exceed the levels given in:

- Table A2 of EN 50178:1998
- Class 3C2 of IEC 60721-3-3

This corresponds to the levels typical of urban areas with industrial activities and/or heavy traffic, but not in the immediate neighborhood of industrial sources with chemical emissions.

### 11.1.11 RoHS compliance

The drive meets EU directive 2002-95-EC for RoHS compliance.

### 11.1.12 Vibration

Maximum recommended continuous vibration level 0.14 g r.m.s. broadband 5 to 200 Hz.

Size 2 & 3:

#### Bump Test

Testing in each of three mutually perpendicular axes in turn.

Referenced standard: IEC 60068-2-27: Test Ea:

Severity: 15 g peak, 11 ms pulse duration, half sine.

No. of Bumps: 18 (3 in each direction of each axis).

Referenced standard: IEC 60068-2-29: Test Eb:

Severity: 18 g peak, 6 ms pulse duration, half sine.

No. of Bumps: 600 (100 in each direction of each axis).

#### Random Vibration Test

Testing in each of three mutually perpendicular axes in turn.

Referenced standard: IEC 60068-2-64: Test Fh:

Severity: 1.0 m<sup>2</sup>/s<sup>3</sup> (0.01 g<sup>2</sup>/Hz) ASD from 5 to 20 Hz

-3 db/octave from 20 to 200 Hz

Duration: 30 minutes in each of 3 mutually perpendicular axes.

#### Sinusoidal Vibration Test

Testing in each of three mutually perpendicular axes in turn.

Referenced standard: IEC 60068-2-6: Test Fc:

Frequency range: 5 to 500 Hz

Severity: 3.5 mm peak displacement from 5 to 9 Hz

10 m/s<sup>2</sup> peak acceleration from 9 to 200 Hz

15 m/s<sup>2</sup> peak acceleration from 200 to 500 Hz

Sweep rate: 1 octave/minute

Duration: 15 minutes in each of 3 mutually perpendicular axes.

Referenced standard: EN 61800-5-1: 2007, Section 5.2.6.4.

referring to IEC 60068-2-6:

Frequency range: 10 to 150 Hz

Severity: 0.075 mm amplitude from 10 to 57 Hz

1g peak acceleration from 57 to 150 Hz

Sweep rate: 1 octave/minute

Duration: 10 sweep cycles per axis in each of 3 mutually perpendicular axes.

#### Testing to Environmental Category ENV3

Subjected to resonance search in the range listed. If no natural frequencies found then subjected only to endurance test.

Referenced standard: Environment Category ENV3:

Frequency range: 5 to 13.2 Hz ± 1.0 mm

13.2 to 100 Hz ± 0.7g (6.9 ms -2)

For more information, please refer to section 12 *Vibration Test 1* of the Lloyds Register Test Specification Number 1.

### 11.1.13 Starts per hour

By electronic control: unlimited

By interrupting the AC supply: ≤20 (equally spaced)

### 11.1.14 Start up time

This is the time taken from the moment of applying power to the drive, to the drive being ready to run the motor:

Sizes 2 & 3: 1.5 seconds

### 11.1.15 Output frequency / speed range

In all operating modes the maximum output frequency is limited to 550 Hz.

### 11.1.16 Accuracy and resolution

#### Frequency:

The absolute frequency accuracy depends on the accuracy of the oscillator used with the drive microprocessor. The accuracy of the oscillator is ± 2 % , and so the absolute frequency accuracy is ± 2 % of the reference, when a preset frequency is used. If an analog input is used, the absolute accuracy is further limited by the absolute accuracy of the analog input.

The following data applies to the drive only; it does not include the performance of the source of the control signals.

Open loop resolution:

Preset frequency reference: 0.01 Hz

Analog input 1: 11 bit plus sign

#### Current:

The resolution of the current feedback is 10 bit plus sign.

Accuracy: typical 2 %

worst case 5 %

### 11.1.17 Acoustic noise

The heatsink fan generates the majority of the sound pressure level at 1 m produced by the drive. The heatsink fan on size 1 to 4 drives is a variable speed fan. The drive controls the speed at which the fan runs based on the temperature of the heatsink and the drive's thermal model system.

Table 11-7 gives the sound pressure level at 1 m produced by the drive for the heatsink fan running at the maximum and minimum speeds.

**Table 11-7 Acoustic noise data**

Size	Max speed dBA	Min speed dBA
1		
2	45	
3	58.6	49
4		

### 11.1.18 Overall dimensions

H Height including surface mounting brackets

W Width

D Projection forward of panel when surface mounted

**Table 11-8 Overall drive dimensions**

Size	Dimension		
	H	W	D
1	160 mm (6.3 in)	75 mm (2.95 in)	130 mm (5.1 in)
2	205 mm (8.07 in)		150 mm (5.9 in)
3	226 mm (8.9 in)	90 mm (3.54 in)	160 mm (6.3 in)
4	277 mm (10.9 in)	115 mm (4.5 in)	175 mm (6.9 in)

### 11.1.19 Weights

Table 11-9 Overall drive weights

Size	Model	kg	lb
1	All	0.75	1.65
2		1.0	2.2
3		1.5	3.3
4		3.13	6.9

### 11.1.20 Input current, fuse and cable size ratings

The input current is affected by the supply voltage and impedance.

#### Typical input current

The values of typical input current are given to aid calculations for power flow and power loss.

The values of typical input current are stated for a balanced supply.

#### Maximum continuous input current

The values of maximum continuous input current are given to aid the selection of cables and fuses. These values are stated for the worst case condition with the unusual combination of stiff supply with bad balance. The value stated for the maximum continuous input current would only be seen in one of the input phases. The current in the other two phases would be significantly lower.

The values of maximum input current are stated for a supply with a 2 % negative phase-sequence imbalance and rated at the maximum supply fault current given in Table 11-10.

Table 11-10 Supply fault current used to calculate maximum input currents

Model	Symmetrical fault level (kA)
All	100



#### Fuses

The AC supply to the drive must be installed with suitable protection against overload and short-circuits. Table 11-11, Table 11-12 and Table 11-13 show the recommended fuse ratings. Failure to observe this requirement will cause risk of fire.

Table 11-11 AC Input current and fuse ratings (100 V)

Model	Typical input current A	Maximum continuous input current A	Maximum overload input current A	Fuse rating	
				IEC gG	Class CC or Class J
				Maximum A	Maximum A
01100017	8.7	8.7		10	10
01100024	11.1	11.1		16	16
02100042	18.8	18.8		20	20
02100056	24.0	24.0		25	25

Table 11-12 AC Input current and fuse ratings (200 V)

Model	Typical input current A	Maximum continuous input current A	Maximum overload input current A	Fuse rating			
				IEC gG		Class CC or Class J	
				Maximum A		Maximum A	
				1ph	3ph	1ph	3ph
01200017	4.5	4.5			5		
01200024	5.3	5.3			10		
01200033	8.3	8.3			16		
01200042	10.4	10.4			16		
02200024	5.3/3.2	5.3/4.1		6	10	5	
02200033	8.3/4.3	8.3/6.7		10	10		
02200042	10.4/5.4	10.4/7.5		16	10	10	
02200056	14.9/7.4	14.9/11.3		20	16	20	16
02200075	18.1/9.1	18.1/13.5					
03200100	23.9/12.8	23.9/17.7	30/25	25	20	25	20
04200133	23.7/13.5	23.7/16.9		25	20	25	20
04200176	17.0	21.3			25		25

**Table 11-13 AC Input current and fuse ratings (400 V)**

Model	Typical input current A	Maximum continuous input current A	Maximum overload input current A	Fuse rating	
				IEC gG	Class CC or Class J
				Maximum A	Maximum A
02400013	2.1	2.4		6	5
02400018	2.6	2.9			
02400023	3.1	3.5			
02400032	4.7	5.1			
02400041	5.8	6.2		10	10
03400056	8.3	8.7	13	10	10
03400073	10.2	12.2	18	16	16
03400094	13.1	14.8	20.7		20
04400135	14.0	16.3		20	20
04400170	18.5	20.7		25	25

**NOTE**

Ensure cables used suit local wiring regulations.



The nominal cable sizes below are only a guide. The mounting and grouping of cables affects their current-carrying capacity, in some cases smaller cables may be acceptable but in other cases a larger cable is required to avoid excessive temperature or voltage drop. Refer to local wiring regulations for the correct size of cables.

**Table 11-14 Cable ratings (100 V)**

Model	Cable size (IEC 60364-5-52) mm <sup>2</sup>				Cable size (UL508C) AWG			
	Input		Output		Input		Output	
	Nominal	Maximum	Nominal	Maximum	Nominal	Maximum	Nominal	Maximum
01100017	1	6	1	2.5	16	10	16	12
01100024	1.5	6	1	2.5	14	10	16	12
02100042	2.5	6	1	2.5	12	10	16	12
02100056	4	6	1	2.5	10	10	16	12

**Table 11-15 Cable ratings (200 V)**

Model	Cable size (IEC 60364-5-52) mm <sup>2</sup>				Cable size (UL 508C) AWG			
	Input		Output		Input		Output	
	Nominal	Maximum	Nominal	Maximum	Nominal	Maximum	Nominal	Maximum
01200017	1	6	1	2.5	16	10	16	12
01200024	1	6	1	2.5	16	10	16	12
01200033	1	6	1	2.5	16	10	16	12
01200042	1	6	1	2.5	16	10	16	12
02200024	1	6	1	2.5	16	10	16	12
02200033	1	6	1	2.5	16	10	16	12
02200042	1	6	1	2.5	16	10	16	12
02200056	2.5/1.5	6	1	2.5	12/14	10	16	12
02200075	2.5	6	1	2.5	12	10	16	12
03200100	4	6	1.5	2.5	10/12	10	14	12
04200133	4/2.5	6	2.5	2.5	10	10	12	12
04200176	4	6	2.5	2.5	10	10	12	12

**Table 11-16 Cable ratings (400 V)**

Model	Cable size (IEC 60364-5-52) mm <sup>2</sup>				Cable size (UL 508C) AWG			
	Input		Output		Input		Output	
	Nominal	Maximum	Nominal	Maximum	Nominal	Maximum	Nominal	Maximum
02400013	1	6	1	2.5	16	10	16	12
02400018	1	6	1	2.5	16	10	16	12
02400023	1	6	1	2.5	16	10	16	12
02400032	1	6	1	2.5	16	10	16	12
02400041	1	6	1	2.5	16	10	16	12
03400056	1	6	1	2.5	14	10	16	12
03400073	1.5	6	1	2.5	12	10	16	12
03400094	2.5	6	1.5	2.5	12	10	14	12
04400135	2.5	6	2.5	2.5	10	10	12	12
04400170	4	6	2.5	2.5	10	10	12	12

**11.1.21 Protective ground cable ratings**

**Table 11-17 Protective ground cable ratings**

Input phase conductor size	Minimum ground conductor size
≤ 10 mm <sup>2</sup>	Either 10 mm <sup>2</sup> or two conductors of the same cross-sectional area as the input phase conductor.
> 10 mm <sup>2</sup> and ≤ 16 mm <sup>2</sup>	The same cross-sectional area as the first input phase conductor.
> 16 mm <sup>2</sup> and ≤ 35 mm <sup>2</sup>	16 mm <sup>2</sup>
> 35 mm <sup>2</sup>	Half of the cross-sectional area of the input phase conductor.

**11.1.22 Maximum motor cable lengths**

**Table 11-18 Maximum motor cable lengths (100 V drives)**

Model	100 V Nominal AC supply voltage								
	Maximum permissible motor cable length for each of the following switching frequencies								
	0.667 kHz	1 kHz	2 kHz	3 kHz	4 kHz	6 kHz	8 kHz	12 kHz	16 kHz
01100017	50 m (164 ft)				37.5 m (123 ft)	25 m (82 ft)	18.75 m (61 ft)	12.5 m (41 ft)	9 m (30 ft)
01100024	50 m (164 ft)				37.5 m (123 ft)	25 m (82 ft)	18.75 m (61 ft)	12.5 m (41 ft)	9 m (30 ft)
02100042	100 m (328 ft)				75 m (246 ft)	50 m (164 ft)	37.5 m (123 ft)	25 m (82 ft)	18 m (59 ft)
02100056	100 m (328 ft)				75 m (246 ft)	50 m (164 ft)	37.5 m (123 ft)	25 m (82 ft)	18 m (59 ft)

**Table 11-19 Maximum motor cable lengths (200 V drives)**

Model	200 V Nominal AC supply voltage								
	Maximum permissible motor cable length for each of the following switching frequencies								
	0.667 kHz	1 kHz	2 kHz	3 kHz	4 kHz	6 kHz	8 kHz	12 kHz	16 kHz
01200017	50 m (164 ft)				37.5 m (123 ft)	25 m (82 ft)	18.75 m (61 ft)	12.5 m (41 ft)	9 m (30 ft)
01200024	50 m (164 ft)				37.5 m (123 ft)	25 m (82 ft)	18.75 m (61 ft)	12.5 m (41 ft)	9 m (30 ft)
01200033	50 m (164 ft)				37.5 m (123 ft)	25 m (82 ft)	18.75 m (61 ft)	12.5 m (41 ft)	9 m (30 ft)
01200042	50 m (164 ft)				37.5 m (123 ft)	25 m (82 ft)	18.75 m (61 ft)	12.5 m (41 ft)	9 m (30 ft)
02200024	100 m (328 ft)				75 m (246 ft)	50 m (164 ft)	37.5 m (123 ft)	25 m (82 ft)	18 m (59 ft)
02200033	100 m (328 ft)				75 m (246 ft)	50 m (164 ft)	37.5 m (123 ft)	25 m (82 ft)	18 m (59 ft)
02200042	100 m (328 ft)				75 m (246 ft)	50 m (164 ft)	37.5 m (123 ft)	25 m (82 ft)	18 m (59 ft)
02200056	100 m (328 ft)				75 m (246 ft)	50 m (164 ft)	37.5 m (123 ft)	25 m (82 ft)	18 m (59 ft)
02200075	100 m (328 ft)				75 m (246 ft)	50 m (164 ft)	37.5 m (123 ft)	25 m (82 ft)	18 m (59 ft)
03200100	100 m (328 ft)				75 m (246 ft)	50 m (164 ft)	37.5 m (123 ft)	25 m (82 ft)	18 m (59 ft)
04200133	100 m (328 ft)				75 m (246 ft)	50 m (164 ft)	37.5 m (123 ft)	25 m (82 ft)	18 m (59 ft)
04200176	100 m (328 ft)				75 m (246 ft)	50 m (164 ft)	37.5 m (123 ft)	25 m (82 ft)	18 m (59 ft)

**Table 11-20 Maximum motor cable lengths (400 V drives)**

Model	400 V Nominal AC supply voltage								
	Maximum permissible motor cable length for each of the following switching frequencies								
	0.667 kHz	1 kHz	2 kHz	3 kHz	4 kHz	6 kHz	8 kHz	12 kHz	16 kHz
02400013	100 m (328 ft)				75 m (246 ft)	50 m (164 ft)	37.5 m (123 ft)	25 m (82 ft)	18.25 m (61 ft)
02400018									
02400023									
02400032									
02400041									
03400056	100 m (328 ft)				75 m (246 ft)	50 m (164 ft)	37.5 m (123 ft)	25 m (82 ft)	18.25 m (61 ft)
03400073									
03400094									
04400135	100 m (328 ft)				75 m (246 ft)	50 m (164 ft)	37.5 m (123 ft)	25 m (82 ft)	18.25 m (61 ft)
04400170									

- Cable lengths in excess of the specified values may be used only when special techniques are adopted; refer to the supplier of the drive.
  - The default switching frequency is 3 kHz for Open-loop.
- The maximum cable length is reduced from that shown in Table 11-18, Table 11-19 and Table 11-20 if high capacitance motor cables are used. For further information, refer to section 4.4.2 *High-capacitance / reduced diameter cables* on page 37.



### 11.1.23 Braking resistor values

**Table 11-21** Minimum resistance values and peak power rating for the braking resistor at 40 °C (104 °F)

Model	Minimum resistance* Ω	Instantaneous power rating kW	Continuous power rating kW
<b>100 V</b>			
01100017	130	1.2	
01100024	130	1.2	
02100042	130	1.2	
02100056	130	1.2	
<b>200 V</b>			
01200017	130	1.2	
01200024	130	1.2	
01200033	130	1.2	
01200042	130	1.2	
02200024	68	2.2	
02200033	68	2.2	
02200042	68	2.2	
02200056	68	2.2	
02200075	68	2.2	
03200100	45	3.4	2.2
04200133	22	6.9	
04200176	22	6.9	
<b>400 V</b>			
02400013	270	2.3	
02400018	270	2.3	
02400023	270	2.3	
02400032	270	2.3	
02400041	270	2.3	
03400056	100	6.1	2.2
03400073	100	6.1	3
03400094	100	6.1	4
04400135	50	12.2	
04400170	50	12.2	

\* Resistor tolerance: ±10 %

### 11.1.24 Torque settings

**Table 11-22** Drive relay terminal data

Model	Connection type	Torque setting
All	Screw terminals	0.5 N m (0.4 lb ft)

**Table 11-23** Drive power terminal data

Model size	AC terminals	DC and braking	Ground terminal
1	0.5 Nm (0.4 lb ft)		1.5 N m (1.0 lb ft)
2	1.4 Nm (1 lb ft)		
3			
4			

**Table 11-24** Terminal block maximum cable sizes

Model size	Terminal block description	Max cable size
All	Control connector	1.5 mm <sup>2</sup> (16 AWG)
	2 way relay connector	2.5 mm <sup>2</sup> (12 AWG)
All	AC input power connector	6 mm <sup>2</sup> (10 AWG)
All	AC output power connector	2.5 mm <sup>2</sup> (12 AWG)

### 11.1.25 Electromagnetic compatibility (EMC)

This is a summary of the EMC performance of the drive. For full details, refer to the *EMC Data Sheet* which can be obtained from the supplier of the drive.

**Table 11-25** Immunity compliance

Standard	Type of immunity	Test specification	Application	Level
IEC61000-4-2 EN61000-4-2	Electrostatic discharge	6 kV contact discharge 8 kV air discharge	Module enclosure	Level 3 (industrial)
IEC61000-4-3 EN61000-4-3	Radio frequency radiated field	10 V/m prior to modulation 80 - 1000 MHz 80 % AM (1 kHz) modulation	Module enclosure	Level 3 (industrial)
IEC61000-4-4 EN61000-4-4	Fast transient burst	5/50 ns 2 kV transient at 5 kHz repetition frequency via coupling clamp	Control lines	Level 4 (industrial harsh)
		5/50 ns 2 kV transient at 5 kHz repetition frequency by direct injection	Power lines	Level 3 (industrial)
IEC61000-4-5 EN61000-4-5	Surges	Common mode 4 kV 1.2/50 μs waveshape	AC supply lines: line to ground	Level 4
		Differential mode 2 kV 1.2/50 μs waveshape	AC supply lines: line to line	Level 3
		Lines to ground	Signal ports to ground <sup>1</sup>	Level 2
IEC61000-4-6 EN61000-4-6	Conducted radio frequency	10V prior to modulation 0.15 - 80 MHz 80 % AM (1 kHz) modulation	Control and power lines	Level 3 (industrial)
IEC61000-4-11 EN61000-4-11	Voltage dips and interruptions	-30 % 10 ms +60 % 100 ms -60 % 1 s <-95 % 5 s	AC power ports	
IEC61000-6-1 EN61000-6-1:2007	Generic immunity standard for the residential, commercial and light - industrial environment			Complies
IEC61000-6-2 EN61000-6-2:2005	Generic immunity standard for the industrial environment			Complies
IEC61800-3 EN61800-3:2004	Product standard for adjustable speed power drive systems (immunity requirements)		Meets immunity requirements for first and second environments	

<sup>1</sup> See section *Surge immunity of control circuits - long cables and connections outside a building* on page 46 for control ports for possible requirements regarding grounding and external surge protection

## Emission

The drive contains an in-built filter for basic emission control. An additional optional external filter provides further reduction of emission. The requirements of the following standards are met, depending on the motor cable length and switching frequency.

**Table 11-26 Size 1 emission compliance (200 V drives)**

Motor cable length (m)	Switching frequency (kHz)					
	3	4	6	8	12	16
Using internal filter:						
0 – 2						
Using internal filter and external ferrite ring (1 turn):						
0 – 10						
10 - 20						
Using external filter:						
0 – 20						
20 - 100						

**Table 11-27 Size 1 emission compliance (400 V drives)**

Motor cable length (m)	Switching frequency (kHz)					
	3	4	6	8	12	16
Using internal filter:						
0 – 5						
Using internal filter and external ferrite ring (2 turns):						
0 – 10						
Using external filter:						
0 – 20						
20 - 100						

**Key** (shown in decreasing order of permitted emission level):

- E2R EN 61800-3:2004 second environment, restricted distribution (Additional measures may be required to prevent interference)
- E2U EN 61800-3:2004 second environment, unrestricted distribution
- I Industrial generic standard EN 61000-6-4:2007  
EN 61800-3:2004 first environment restricted distribution (The following caution is required by EN 61800-3:2004)

	This is a product of the restricted distribution class according to IEC 61800-3. In a residential environment this product may cause radio interference in which case the user may be required to take adequate measures.
<b>CAUTION</b>	

- R Residential generic standard EN 61000-6-3:2007  
EN 61800-3:2004 first environment unrestricted distribution

EN 61800-3:2004 defines the following:

- The first environment is one that includes residential premises. It also includes establishments directly connected without intermediate transformers to a low-voltage power supply network which supplies buildings used for residential purposes.
- The second environment is one that includes all establishments other than those directly connected to a low-voltage power supply network which supplies buildings used for residential purposes.
- Restricted distribution is defined as a mode of sales distribution in which the manufacturer restricts the supply of equipment to suppliers, customers or users who separately or jointly have technical competence in the EMC requirements of the application of drives.

### IEC 61800-3:2004 and EN 61800-3:2004

The 2004 revision of the standard uses different terminology to align the requirements of the standard better with the EC EMC Directive.

Power drive systems are categorized C1 to C4:

Category	Definition	Corresponding code used above
C1	Intended for use in the first or second environments	R
C2	Not a plug-in or movable device, and intended for use in the first environment only when installed by a professional, or in the second environment	I
C3	Intended for use in the second environment, not the first environment	E2U
C4	Rated at over 1000 V or over 400 A, intended for use in complex systems in the second environment	E2R

Note that category 4 is more restrictive than E2R, since the rated current of the PDS must exceed 400 A or the supply voltage exceed 1000 V, for the complete PDS.

## 11.2 Optional external EMC filters

**Table 11-28 EMC filter cross reference**

Model	CT Part number
<b>200 V</b>	
<b>400 V</b>	

### 11.2.1 EMC filter ratings

Table 11-29 Optional external EMC filter details

CT part number	Maximum continuous current		Voltage rating		IP rating	Power dissipation at rated current		Ground leakage		Discharge resistors
	@ 40 °C (104 °F)	@ 50 °C (122 °F)	IEC	UL		@ 40 °C (104 °F)	@ 50 °C (122 °F)	Balanced supply phase-to-phase and phase-to-ground	Worst case	
	A	A	V	V		W	W	mA	mA	

### 11.2.2 Overall EMC filter dimensions

Table 11-30 Optional external EMC filter dimensions

CT part number	Dimension (mm)						Weight	
	H		W		D		kg	lb
	mm	inch	mm	inch	mm	inch		

### 11.2.3 EMC filter torque settings

Table 11-31 Optional external EMC Filter terminal data

CT part number	Power connections				Ground connections		
	Max cable size		Max torque		Ground stud size	Max torque	
	mm <sup>2</sup>	AWG	N m	lb ft		N m	lb ft

## 12 Diagnostics

The keypad display on the drive gives various information about the status of the drive. The keypad display provides information on the following categories:

- Trip indications
- Alarm indications
- Status indications



Users must not attempt to repair a drive if it is faulty, nor carry out fault diagnosis other than through the use of the diagnostic features described in this chapter. If a drive is faulty, it must be returned to an authorized Control Techniques distributor for repair.

### 12.1 Status modes

Figure 12-1 Keypad status modes

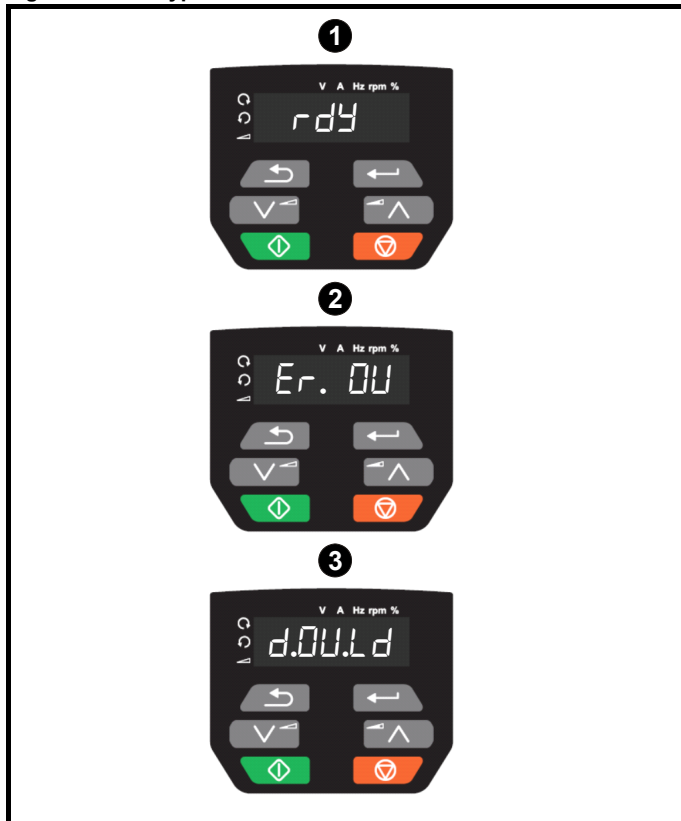

- 1 Drive OK status
- 2 Trip status
- 3 Alarm status

### 12.2 Trip indications

The output of the drive is disabled under any trip condition so that the drive stops controlling the motor. If the motor is running when the trip occurs it will coast to a stop.

During a trip condition, the display indicates that a trip has occurred and the keypad will display the trip string. Some trips have a sub-trip number to provide additional information about the trip. If a trip has a sub-trip number, the sub-trip number is flashed alternately with the trip string.

Trips are listed alphabetically in Table 12-2 based on the trip indication shown on the drive display.

### 12.3 Identifying a trip / trip source

Some trips only contain a trip string whereas some other trips have a trip string along with a sub-trip number which provides the user with additional information about the trip.

A trip can be generated from a control system or from a power system. The sub-trip number associated with the trips listed in Table 12-1 is in the form xxyz and used to identify the source of the trip.

Table 12-1 Trips associated with xxyz sub-trip number

OV	PH.Lo
OI.AC	Pb.Er
OI.br	OI.Sn
PSU	Oht.r
Oht.l	tH.Fb
Oht.P	P.dAt
Oh.dc	So.St

The digits xx are 00 for a trip generated by the control system. For a drive, if the trip is related to the power system then xx will have a value of 01, when displayed the leading zeros are suppressed.

For a control system trip (xx is zero), the y digit where relevant is defined for each trip. If not relevant, the y digit will have a value of zero.

The zz digits give the reason for the trip and are defined in each trip description.

Figure 12-2 Key to sub-trip number

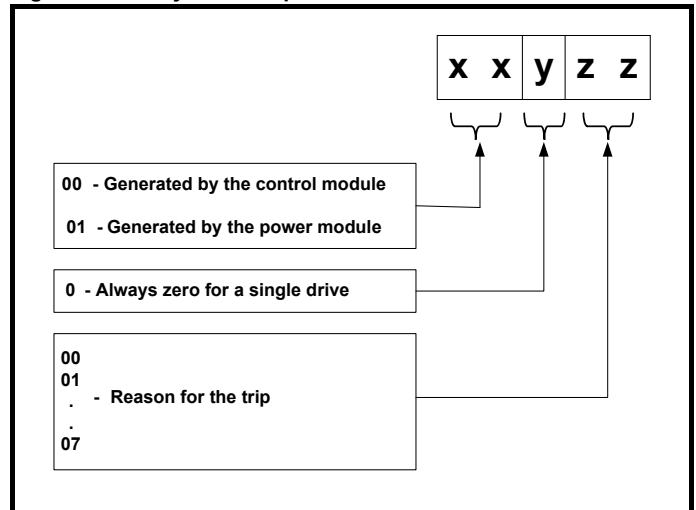

## 12.4 Trips, Sub-trip numbers

Table 12-2 Trip indications

Trip	Diagnosis								
<b>C.Acc</b>	<b>NV Media Card Write fail</b>								
185	<p>The <i>C.Acc</i> trip indicates that the drive was unable to access the NV Media Card. If the trip occurs during the data transfer to the card then the file being written may be corrupted. If the trip occurs when the data being transferred to the drive then the data transfer may be incomplete. If a parameter file is transferred to the drive and this trip occurs during the transfer, the parameters are not saved to non-volatile memory, and so the original parameters can be restored by powering the drive down and up again.</p> <p><b>Recommended actions:</b></p> <ul style="list-style-type: none"> <li>• Check NV Media Card is installed / located correctly</li> <li>• Replace the NV Media Card</li> </ul>								
<b>C.bt</b>	<b>The Menu 0 parameter modification cannot be saved to the NV Media Card</b>								
177	<p>Menu 0 changes are automatically saved on exiting edit mode.</p> <p>The <i>C.bt</i> trip will occur if a write to a Menu 0 parameter has been initiated via the keypad by exiting edit mode and Pr <b>11.042</b> is set for auto or boot mode, but the necessary boot file has not been created on the NV Media Card to take the new parameter value. This occurs when Pr <b>11.042</b> is changed to Auto (3) or Boot (4) mode, but the drive is not subsequently reset.</p> <p><b>Recommended actions:</b></p> <ul style="list-style-type: none"> <li>• Ensure that Pr <b>11.042</b> is correctly set, and then reset the drive to create the necessary file on the NV Media Card</li> <li>• Re-attempt the parameter write to the Menu 0 parameter</li> </ul>								
<b>C.cPr</b>	<b>NV Media Card file/data is different to the one in the drive</b>								
188	<p>A compare has been carried out between a file on the NV Media Card, a <i>C.cPr</i> trip is initiated if the parameters on the NV Media Card are different to the drive.</p> <p><b>Recommended actions:</b></p> <ul style="list-style-type: none"> <li>• Set Pr <b>mm.000</b> to 0 and reset the trip</li> <li>• Check to ensure the correct data block on the NV Media Card has been used for the compare</li> </ul>								
<b>C.dE</b>	<b>NV Media Card data location already contains data</b>								
179	<p>The <i>C.dE</i> trip indicates that an attempt has been made to store data on a NV Media Card in a data block which already contains data.</p> <p><b>Recommended actions:</b></p> <ul style="list-style-type: none"> <li>• Erase the data in data location</li> <li>• Write data to an alternative data location</li> </ul>								
<b>C.dAt</b>	<b>NV Media Card data not found</b>								
183	<p>The <i>C.dAt</i> trip indicates that an attempt has been made to access non-existent file or block on the NV Media Card.</p> <p><b>Recommended actions:</b></p> <ul style="list-style-type: none"> <li>• Ensure data block number is correct</li> </ul>								
<b>C.Err</b>	<b>NV Media Card data structure error</b>								
182	<p>The <i>C.Err</i> trip indicates that an attempt has been made to access the NV Media Card but an error has been detected in the data structure on the card. Resetting the trip will cause the drive to erase and create the correct folder structure. The cause of the trip can be identified by the sub-trip.</p> <table border="1"> <thead> <tr> <th>Sub-trip</th> <th>Reason</th> </tr> </thead> <tbody> <tr> <td>1</td> <td>The required folder and file structure is not present</td> </tr> <tr> <td>2</td> <td>The HEADER.DAT file is corrupted</td> </tr> <tr> <td>3</td> <td>Two or more files in the OLDATA\DRIVE folder have the same file identification number</td> </tr> </tbody> </table> <p><b>Recommended actions:</b></p> <ul style="list-style-type: none"> <li>• Erase all the data block and re-attempt the process</li> <li>• Ensure the card is located correctly</li> <li>• Replace the NV Media Card</li> </ul>	Sub-trip	Reason	1	The required folder and file structure is not present	2	The HEADER.DAT file is corrupted	3	Two or more files in the OLDATA\DRIVE folder have the same file identification number
Sub-trip	Reason								
1	The required folder and file structure is not present								
2	The HEADER.DAT file is corrupted								
3	Two or more files in the OLDATA\DRIVE folder have the same file identification number								
<b>C.FuL</b>	<b>NV Media Card full</b>								
184	<p>The <i>C.FuL</i> trip indicates that an attempt has been made to create a data block on a NV Media Card, but there is not enough space left on the card.</p> <p><b>Recommended actions:</b></p> <ul style="list-style-type: none"> <li>• Delete a data block or the entire NV Media Card to create space</li> <li>• Use a different NV Media Card</li> </ul>								

Trip	Diagnosis						
<b>C.Pr</b>	<b>NV Media Card data blocks are not compatible with the drive derivative</b>						
175	<p>The <i>C.Pr</i> trip is initiated either at power-up or when the card is accessed, If <i>Drive Derivative</i> (11.028) is different between the source and target drives. This trip can be reset and data can be transferred in either direction between the drive and the card.</p> <p><b>Recommended actions:</b></p> <ul style="list-style-type: none"> <li>Use a different NV Media Card</li> <li>This trip can be suppressed by setting Pr <b>mm.000</b> to 9666 and resetting the drive</li> </ul>						
<b>C.rdo</b>	<b>NV Media Card has the Read Only bit set</b>						
181	<p>The <i>C.rdo</i> trip indicates that an attempt has been made to modify a read-only NV Media Card or a read-only data block. A NV Media Card is read-only if the read-only flag has been set.</p> <p><b>Recommended actions:</b></p> <ul style="list-style-type: none"> <li>Clear the read only flag by setting Pr <b>mm.000</b> to 9777 and reset the drive. This will clear the read-only flag for all data blocks in the NV Media Card</li> </ul>						
<b>C.rtg</b>	<b>NV Media Card Trip; The voltage and / or current rating of the source and destination drives are different</b>						
186	<p>The <i>C.rtg</i> trip indicates that parameter data is being transferred from the NV Media Card to the drive, but the current and / or voltage ratings are different between source and destination drives. This trip also applies if a compare (using Pr <b>mm.000</b> set to 8yyy) is attempted between the data block on a NV Media Card and the drive. The <i>C.rtg</i> trip does not stop the data transfer but is a warning that rating specific parameters with the RA attribute may not be transferred to the destination drive.</p> <p><b>Recommended actions:</b></p> <ul style="list-style-type: none"> <li>Reset the drive to clear the trip</li> <li>Ensure that the drive rating dependent parameters have transferred correctly</li> </ul>						
<b>C.tyP</b>	<b>NV Media Card parameter set not compatible with current drive mode</b>						
187	<p>The <i>C.tyP</i> trip is produced during a compare if the drive mode in the data block on the NV Media Card is different from the current drive mode. This trip is also produced if an attempt is made to transfer parameters from a NV Media Card to the drive if the operating mode in the data block is outside the allowed range of operating modes.</p> <p><b>Recommended actions:</b></p> <ul style="list-style-type: none"> <li>Ensure the destination drive supports the drive operating mode in the parameter file.</li> <li>Clear the value in Pr <b>mm.000</b> and reset the drive</li> <li>Ensure destination drive operating mode is the same as the source parameter file</li> </ul>						
<b>cL.A1</b>	<b>Analog input 1 current loss</b>						
28	<p>The <i>cL.A1</i> trip indicates that a current loss was detected in current mode on Analog input 1 (Terminal 2). In 4-20 mA and 20-4 mA modes loss of input is detected if the current falls below 3 mA.</p> <p><b>Recommended actions:</b></p> <ul style="list-style-type: none"> <li>Check control wiring is correct</li> <li>Check control wiring is undamaged</li> <li>Check the <i>Analog Input 1 Mode</i> (07.007)</li> <li>Current signal is present and greater than 3 mA</li> </ul>						
<b>Cur.c</b>	<b>Current calibration range</b>						
231	Current calibration range error.						
<b>Cur.O</b>	<b>Current feedback offset error</b>						
225	<p>The <i>Cur.O</i> trip indicates that the current offset is too large to be trimmed.</p> <p><b>Recommended actions:</b></p> <ul style="list-style-type: none"> <li>Ensure that there is no possibility of current flowing in the output phases of the drive when the drive is not enabled</li> <li>Hardware fault – Contact the supplier of the drive</li> </ul>						
<b>d.Ch</b>	<b>Drive parameters are being changed</b>						
97	<p>A user action or a file system write is active that is changing the drive parameters and the drive has been commanded to enable, i.e. <i>Drive Active</i> (10.002) = 1.</p> <p><b>Recommended actions:</b></p> <ul style="list-style-type: none"> <li>Ensure the drive is not enabled when defaults are being loaded</li> </ul>						
<b>dEr.E</b>	<b>Derivative file error</b>						
246	<p>Derivative file error with sub-trips:</p> <table border="1"> <thead> <tr> <th>Sub-trip</th> <th>Reason</th> </tr> </thead> <tbody> <tr> <td>1</td> <td>Derivative file different</td> </tr> <tr> <td>2</td> <td>Derivative file missing</td> </tr> </tbody> </table>	Sub-trip	Reason	1	Derivative file different	2	Derivative file missing
Sub-trip	Reason						
1	Derivative file different						
2	Derivative file missing						

Trip	Diagnosis																																																												
<b>dEr.I</b>	<b>Derivative product image error</b>																																																												
<b>248</b>	The <i>dEr.I</i> trip indicates that an error has been detected in the derivative product image. The reason for the trip can be identified by the sub-trip number.																																																												
	<table border="1"> <thead> <tr> <th>Sub-trip</th> <th>Reason</th> <th>Comments</th> </tr> </thead> <tbody> <tr> <td>1</td> <td>Divide by zero</td> <td></td> </tr> <tr> <td>2</td> <td>Undefined trip</td> <td></td> </tr> <tr> <td>3</td> <td>Attempted fast parameter access set-up with non-existent parameter</td> <td></td> </tr> <tr> <td>4</td> <td>Attempted access to non-existent parameter</td> <td></td> </tr> <tr> <td>5</td> <td>Attempted write to read-only parameter</td> <td></td> </tr> <tr> <td>6</td> <td>Attempted and over-range write</td> <td></td> </tr> <tr> <td>7</td> <td>Attempted read from write-only parameter</td> <td></td> </tr> <tr> <td>30</td> <td>The image has failed because either its CRC is incorrect, or there are less than 6 bytes in the image or the image header version is less than 5</td> <td>Occurs when the drive powers-up or the image is programmed. The image tasks will not run</td> </tr> <tr> <td>31</td> <td>The image requires more RAM for heap and stack than can be provided by the drive.</td> <td>As 30</td> </tr> <tr> <td>32</td> <td>The image requires an OS function call that is higher than the maximum allowed.</td> <td>As 30</td> </tr> <tr> <td>33</td> <td>The ID code within the image is not valid</td> <td>As 30</td> </tr> <tr> <td>34</td> <td>The derivative image has been changed for an image with a different derivative number</td> <td>As 30</td> </tr> <tr> <td>40</td> <td>The timed task has not completed in time and has been suspended</td> <td></td> </tr> <tr> <td>41</td> <td>Undefined function called, i.e. a function in the host system vector table that has not been assigned</td> <td>As 40</td> </tr> <tr> <td>51</td> <td>Core menu customization table CRC check failed</td> <td>As 30</td> </tr> <tr> <td>52</td> <td>Customizable menu table CRC check failed</td> <td>As 30</td> </tr> <tr> <td>53</td> <td>Customizable menu table changed</td> <td>Occurs when the drive powers-up or the image is programmed and the table has changed. Defaults are loaded for the derivative menu and the trip will keep occurring until drive parameters are saved.</td> </tr> <tr> <td>80</td> <td>Image is not compatible with the control board</td> <td>Initiated from within the image code</td> </tr> <tr> <td>81</td> <td>Image is not compatible with the control board serial number</td> <td>As 80</td> </tr> </tbody> </table>	Sub-trip	Reason	Comments	1	Divide by zero		2	Undefined trip		3	Attempted fast parameter access set-up with non-existent parameter		4	Attempted access to non-existent parameter		5	Attempted write to read-only parameter		6	Attempted and over-range write		7	Attempted read from write-only parameter		30	The image has failed because either its CRC is incorrect, or there are less than 6 bytes in the image or the image header version is less than 5	Occurs when the drive powers-up or the image is programmed. The image tasks will not run	31	The image requires more RAM for heap and stack than can be provided by the drive.	As 30	32	The image requires an OS function call that is higher than the maximum allowed.	As 30	33	The ID code within the image is not valid	As 30	34	The derivative image has been changed for an image with a different derivative number	As 30	40	The timed task has not completed in time and has been suspended		41	Undefined function called, i.e. a function in the host system vector table that has not been assigned	As 40	51	Core menu customization table CRC check failed	As 30	52	Customizable menu table CRC check failed	As 30	53	Customizable menu table changed	Occurs when the drive powers-up or the image is programmed and the table has changed. Defaults are loaded for the derivative menu and the trip will keep occurring until drive parameters are saved.	80	Image is not compatible with the control board	Initiated from within the image code	81	Image is not compatible with the control board serial number	As 80
	Sub-trip	Reason	Comments																																																										
	1	Divide by zero																																																											
	2	Undefined trip																																																											
	3	Attempted fast parameter access set-up with non-existent parameter																																																											
	4	Attempted access to non-existent parameter																																																											
	5	Attempted write to read-only parameter																																																											
	6	Attempted and over-range write																																																											
	7	Attempted read from write-only parameter																																																											
	30	The image has failed because either its CRC is incorrect, or there are less than 6 bytes in the image or the image header version is less than 5	Occurs when the drive powers-up or the image is programmed. The image tasks will not run																																																										
	31	The image requires more RAM for heap and stack than can be provided by the drive.	As 30																																																										
	32	The image requires an OS function call that is higher than the maximum allowed.	As 30																																																										
	33	The ID code within the image is not valid	As 30																																																										
	34	The derivative image has been changed for an image with a different derivative number	As 30																																																										
	40	The timed task has not completed in time and has been suspended																																																											
	41	Undefined function called, i.e. a function in the host system vector table that has not been assigned	As 40																																																										
	51	Core menu customization table CRC check failed	As 30																																																										
	52	Customizable menu table CRC check failed	As 30																																																										
	53	Customizable menu table changed	Occurs when the drive powers-up or the image is programmed and the table has changed. Defaults are loaded for the derivative menu and the trip will keep occurring until drive parameters are saved.																																																										
80	Image is not compatible with the control board	Initiated from within the image code																																																											
81	Image is not compatible with the control board serial number	As 80																																																											
	<p><b>Recommended actions:</b></p> <ul style="list-style-type: none"> <li>Contact the supplier of the drive</li> </ul>																																																												
<b>dEst</b>	<b>Two or more parameters are writing to the same destination parameter</b>																																																												
<b>199</b>	The <i>dest</i> trip indicates that destination output parameters of two or more logic functions (Menus 7 and 8) within the drive are writing to the same parameter. <p><b>Recommended actions:</b></p> <ul style="list-style-type: none"> <li>Set Pr <b>mm.000</b> to 'Destinations' or 12001 and check all visible parameters in all menus for parameter write conflicts</li> </ul>																																																												
<b>dr.CF</b>	<b>Drive configuration</b>																																																												
<b>232</b>	The hardware ID does not match the user software ID.																																																												

Trip	Diagnosis																				
<b>EEF</b>	<b>Default parameters have been loaded</b>																				
	The <i>EEF</i> trip indicates that default parameters have been loaded. The exact cause/reason of the trip can be identified from the sub-trip number.																				
	<table border="1"> <thead> <tr> <th>Sub-trip</th> <th>Reason</th> </tr> </thead> <tbody> <tr> <td>1</td> <td>The most significant digit of the internal parameter database version number has changed</td> </tr> <tr> <td>2</td> <td>The CRC's applied to the parameter data stored in internal non-volatile memory indicate that a valid set of parameters cannot be loaded</td> </tr> <tr> <td>3</td> <td>The drive mode restored from internal non-volatile memory is outside the allowed range for the product or the derivative image does not allow the previous drive mode</td> </tr> <tr> <td>4</td> <td>The drive derivative image has changed</td> </tr> <tr> <td>5</td> <td>The power stage hardware has changed</td> </tr> <tr> <td>6</td> <td>The internal I/O hardware has changed</td> </tr> <tr> <td>7</td> <td>Reserved</td> </tr> <tr> <td>8</td> <td>The control board hardware has changed</td> </tr> <tr> <td>9</td> <td>The checksum on the non-parameter area of the EEPROM has failed</td> </tr> </tbody> </table>	Sub-trip	Reason	1	The most significant digit of the internal parameter database version number has changed	2	The CRC's applied to the parameter data stored in internal non-volatile memory indicate that a valid set of parameters cannot be loaded	3	The drive mode restored from internal non-volatile memory is outside the allowed range for the product or the derivative image does not allow the previous drive mode	4	The drive derivative image has changed	5	The power stage hardware has changed	6	The internal I/O hardware has changed	7	Reserved	8	The control board hardware has changed	9	The checksum on the non-parameter area of the EEPROM has failed
Sub-trip	Reason																				
1	The most significant digit of the internal parameter database version number has changed																				
2	The CRC's applied to the parameter data stored in internal non-volatile memory indicate that a valid set of parameters cannot be loaded																				
3	The drive mode restored from internal non-volatile memory is outside the allowed range for the product or the derivative image does not allow the previous drive mode																				
4	The drive derivative image has changed																				
5	The power stage hardware has changed																				
6	The internal I/O hardware has changed																				
7	Reserved																				
8	The control board hardware has changed																				
9	The checksum on the non-parameter area of the EEPROM has failed																				
<b>31</b>																					
	<p><b>Recommended actions:</b></p> <ul style="list-style-type: none"> <li>• Default the drive and perform a reset</li> <li>• Allow sufficient time to perform a save before the supply to the drive is removed</li> <li>• If the trip persists - return drive to supplier</li> </ul>																				
<b>Et</b>	<b>An External trip is initiated</b>																				
	An <i>Et</i> trip has occurred. The cause of the trip can be identified from the sub trip number displayed after the trip string. See table below. An external trip can also be initiated by writing a value of 6 in Pr <b>10.038</b> .																				
	<table border="1"> <thead> <tr> <th>Sub-trip</th> <th>Reason</th> </tr> </thead> <tbody> <tr> <td>1</td> <td><i>External Trip</i> (10.032) = 1</td> </tr> </tbody> </table>	Sub-trip	Reason	1	<i>External Trip</i> (10.032) = 1																
Sub-trip	Reason																				
1	<i>External Trip</i> (10.032) = 1																				
<b>6</b>																					
	<p><b>Recommended actions:</b></p> <ul style="list-style-type: none"> <li>• Check the value of Pr <b>10.032</b>.</li> <li>• Select 'Dest' (or enter 12001) in Pr <b>mm.000</b> and check for a parameter controlling Pr <b>10.032</b>.</li> </ul>																				
<b>FAN.F</b>	<b>Fan fail</b>																				
	Recommended actions:																				
<b>173</b>	<ul style="list-style-type: none"> <li>• Check that the fan is installed and connected correctly.</li> <li>• Check that the fan is not obstructed.</li> <li>• Contact the supplier of the drive to replace the fan.</li> </ul>																				
<b>Fi.Ch</b>	<b>File changed</b>																				
	Recommended action:																				
<b>247</b>	<ul style="list-style-type: none"> <li>• Power cycle the drive.</li> </ul>																				
<b>FI.In</b>	<b>Firmware Incompatibility</b>																				
	The <i>FI.In</i> trip indicates that the user firmware is incompatible with the power firmware.																				
	<b>Recommended actions:</b>																				
<b>237</b>	Re-program the drive with the latest version of the drive firmware for <i>Unidrive M100</i> .																				
	The <i>FW</i> incompatible trip indicates that the user firmware is incompatible with the power firmware.																				
<b>HF01</b>	<b>Data processing error: CPU hardware fault</b>																				
	The <i>HF01</i> trip indicates that a CPU address error has occurred. This trip indicates that the control PCB on the drive has failed.																				
	<b>Recommended actions:</b>																				
	<ul style="list-style-type: none"> <li>• Hardware fault – Contact the supplier of the drive</li> </ul>																				
<b>HF02</b>	<b>Data processing error: CPU memory management fault</b>																				
	The <i>HF02</i> trip indicates that a DMAC address error has occurred. This trip indicates that the control PCB on the drive has failed.																				
	<b>Recommended actions:</b>																				
	<ul style="list-style-type: none"> <li>• Hardware fault – Contact the supplier of the drive</li> </ul>																				
<b>HF03</b>	<b>Data processing error: CPU has detected a bus fault</b>																				
	The <i>HF03</i> trip indicates that a bus fault has occurred. This trip indicates that the control PCB on the drive has failed.																				
	<b>Recommended actions:</b>																				
	<ul style="list-style-type: none"> <li>• Hardware fault – Contact the supplier of the drive</li> </ul>																				



Trip	Diagnosis									
<b>HF04</b>	<b>Data processing error: CPU has detected a usage fault</b>									
	The <i>HF04</i> trip indicates that a usage fault has occurred. This trip indicates that the control PCB on the drive has failed. <b>Recommended actions:</b> <ul style="list-style-type: none"> <li>Hardware fault – Contact the supplier of the drive</li> </ul>									
<b>HF05</b>	<b>Reserved</b>									
<b>HF06</b>	<b>Reserved</b>									
<b>HF07</b>	<b>Data processing error: Watchdog failure</b>									
	The <i>HF07</i> trip indicates that a watchdog failure has occurred. This trip indicates that the control PCB on the drive has failed. <b>Recommended actions:</b> <ul style="list-style-type: none"> <li>Hardware fault – Contact the supplier of the drive</li> </ul>									
<b>HF08</b>	<b>Data processing error: CPU interrupt crash</b>									
	The <i>HF08</i> trip indicates that a CPU interrupt crash has occurred. This trip indicates that the control PCB on the drive has failed. The crash level is indicated by the sub-trip number. <b>Recommended actions:</b> <ul style="list-style-type: none"> <li>Hardware fault – Contact the supplier of the drive</li> </ul>									
<b>HF09</b>	<b>Data processing error: Free store overflow</b>									
	The <i>HF09</i> trip indicates that a free store overflow has occurred. This trip indicates that the control PCB on the drive has failed. <b>Recommended actions:</b> <ul style="list-style-type: none"> <li>Hardware fault – Contact the supplier of the drive</li> </ul>									
<b>HF10</b>	<b>Reserved</b>									
<b>HF11</b>	<b>Data processing error: Non-volatile memory comms error</b>									
	The <i>HF11</i> trip indicates that a non-volatile memory comms error has occurred. <table border="1" data-bbox="352 1010 1458 1129"> <thead> <tr> <th>Sub-trip</th> <th>Reason</th> <th>Recommended action</th> </tr> </thead> <tbody> <tr> <td>1</td> <td>Non-volatile memory comms error.</td> <td>Hardware fault – contact the supplier of the drive.</td> </tr> <tr> <td>2</td> <td>EEPROM size is incompatible with the user firmware.</td> <td>Re-program drive with compatible user firmware.</td> </tr> </tbody> </table>	Sub-trip	Reason	Recommended action	1	Non-volatile memory comms error.	Hardware fault – contact the supplier of the drive.	2	EEPROM size is incompatible with the user firmware.	Re-program drive with compatible user firmware.
Sub-trip	Reason	Recommended action								
1	Non-volatile memory comms error.	Hardware fault – contact the supplier of the drive.								
2	EEPROM size is incompatible with the user firmware.	Re-program drive with compatible user firmware.								
<b>HF12</b>	<b>Data processing error: main program stack overflow</b>									
	The <i>HF12</i> trip indicates that the main program stack overflow has occurred. The stack can be identified by the sub-trip number. This trip indicates that the control PCB has failed. <table border="1" data-bbox="352 1283 960 1402"> <thead> <tr> <th>Sub-trip</th> <th>Stack</th> </tr> </thead> <tbody> <tr> <td>1</td> <td>Freewheeling tasks</td> </tr> <tr> <td>2</td> <td>Reserved</td> </tr> <tr> <td>3</td> <td>Main system interrupts</td> </tr> </tbody> </table>	Sub-trip	Stack	1	Freewheeling tasks	2	Reserved	3	Main system interrupts	
Sub-trip	Stack									
1	Freewheeling tasks									
2	Reserved									
3	Main system interrupts									
<b>HF13</b>	<b>Reserved</b>									
<b>HF14</b>	<b>Reserved</b>									
<b>HF15</b>	<b>Reserved</b>									
<b>HF16</b>	<b>Data processing error: RTOS error</b>									
	The <i>HF16</i> trip indicates that a RTOS error has occurred. This trip indicates that the control PCB on the drive has failed. <b>Recommended actions:</b> <ul style="list-style-type: none"> <li>Hardware fault – Contact the supplier of the drive</li> </ul>									
<b>HF17</b>	<b>Reserved</b>									
<b>HF18</b>	<b>Reserved</b>									

Trip	Diagnosis																
<b>HF19</b>	<b>Data processing error: CRC check on the firmware has failed</b>																
	The <i>HF19</i> trip indicates that the CRC check on the drive firmware has failed. <b>Recommended actions:</b> <ul style="list-style-type: none"> <li>Re-program the drive</li> <li>Hardware fault - Contact the supplier of the drive</li> </ul>																
<b>It.Ac</b>	<b>Output current overload timed out (I<sup>2</sup>t)</b>																
<b>20</b>	The <i>It.Ac</i> trip indicates a motor thermal overload based on the output current (Pr <b>05.007</b> ) and motor thermal time constant (Pr <b>04.015</b> ). Pr <b>04.019</b> displays the motor temperature as a percentage of the maximum value. The drive will trip on <i>It.Ac</i> when Pr <b>04.019</b> gets to 100 %. <b>Recommended actions:</b> <ul style="list-style-type: none"> <li>Ensure the load is not jammed / sticking</li> <li>Check the load on the motor has not changed</li> <li>Ensure the motor rated current is not zero</li> </ul>																
<b>It.br</b>	<b>Braking resistor overload timed out (I<sup>2</sup>t)</b>																
<b>19</b>	The <i>It.br</i> trip indicates that braking resistor overload has timed out. The value in <i>Braking Resistor Thermal Accumulator</i> (10.039) is calculated using <i>Braking Resistor Rated Power</i> (10.030), <i>Braking Resistor Thermal Time Constant</i> (10.031) and <i>Braking Resistor Resistance</i> (10.061). The <i>It.br</i> trip is initiated when the <i>Braking Resistor Thermal Accumulator</i> (10.039) reaches 100 %. <b>Recommended actions:</b> <ul style="list-style-type: none"> <li>Ensure the values entered in Pr <b>10.030</b>, Pr <b>10.031</b> and Pr <b>10.061</b> are correct</li> <li>If an external thermal protection device is being used and the braking resistor software overload protection is not required, set Pr <b>10.030</b>, Pr <b>10.031</b> or Pr <b>10.061</b> to 0 to disable the trip.</li> </ul>																
<b>LF.Er</b>	<b>Communication has been lost / errors detected between power, control and rectifier modules</b>																
<b>90</b>	This trip is initiated if there is no communications between power, control or the rectifier module or if excessive communication errors have been detected. The reason for the trip can be identified by the sub-trip number. <table border="1" data-bbox="311 934 1465 1129"> <thead> <tr> <th>Source</th> <th>xx</th> <th>y</th> <th>zz</th> </tr> </thead> <tbody> <tr> <td>Control system</td> <td>00</td> <td>0</td> <td>01: No communications between the control system and the power system.</td> </tr> <tr> <td>Control system</td> <td>00</td> <td>0</td> <td>02: Excessive communication errors between the control system and power system.</td> </tr> <tr> <td>Control system</td> <td>01</td> <td>1</td> <td>00: Excessive communications errors detected by the rectifier module.</td> </tr> </tbody> </table> <b>Recommended actions:</b> <ul style="list-style-type: none"> <li>Hardware fault - contact the supplier of the drive.</li> </ul>	Source	xx	y	zz	Control system	00	0	01: No communications between the control system and the power system.	Control system	00	0	02: Excessive communication errors between the control system and power system.	Control system	01	1	00: Excessive communications errors detected by the rectifier module.
Source	xx	y	zz														
Control system	00	0	01: No communications between the control system and the power system.														
Control system	00	0	02: Excessive communication errors between the control system and power system.														
Control system	01	1	00: Excessive communications errors detected by the rectifier module.														
<b>no.PS</b>	<b>No power board</b>																
<b>236</b>	No communication between the power and control boards. <b>Recommended actions:</b> <ul style="list-style-type: none"> <li>Check connection between power and control board.</li> </ul>																
<b>O.Ld1</b>	<b>Digital output overload</b>																
<b>26</b>	The <i>O.Ld1</i> trip indicates that the total current drawn from 24 V user supply or from the digital output has exceeded the limit. A trip is initiated if the following condition is met: <ul style="list-style-type: none"> <li>Maximum output current from one digital output is 100 mA.</li> </ul> <b>Recommended actions:</b> <ul style="list-style-type: none"> <li>Check total loads on digital outputs</li> <li>Check control wiring is correct</li> <li>Check output wiring is undamaged</li> </ul>																
<b>O.SPd</b>	<b>Motor frequency has exceeded the over frequency threshold</b>																
<b>7</b>	In open-loop mode, if the Post-ramp Reference (02.001) exceeds the threshold set in the Over Frequency Threshold (03.008) in either direction, an O.SPd trip is produced. If Pr 3.008 is set to 0.00 the threshold is then equal to 1.2 x the value set in Pr 1.006. <b>Recommended actions:</b> <ul style="list-style-type: none"> <li>Check that a mechanical load is not driving motor'</li> </ul>																
<b>Oh.br</b>	<b>Braking IGBT over-temperature</b>																
<b>101</b>	The <i>Oh.br</i> over-temperature trip indicates that braking IGBT over-temperature has been detected based on software thermal model. <b>Recommended actions:</b> <ul style="list-style-type: none"> <li>Check braking resistor value is greater than or equal to the minimum resistance value</li> </ul>																

Trip	Diagnosis										
<b>Oh.dc</b>	<b>DC bus over temperature</b>										
27	<p>The <i>Oh.dc</i> trip indicates a DC bus component over temperature based on a software thermal model. The drive includes a thermal protection system to protect the DC bus components within the drive. This includes the effects of the output current and DC bus ripple. The estimated temperature is displayed as a percentage of the trip level in Pr <b>07.035</b>. If this parameter reaches 100 % then an <i>Oh.dc</i> trip is initiated. The drive will attempt to stop the motor before tripping. If the motor does not stop in 10 seconds the drive trips immediately.</p> <table border="1"> <thead> <tr> <th>Source</th> <th>xx</th> <th>y</th> <th>zz</th> <th>Description</th> </tr> </thead> <tbody> <tr> <td>Control system</td> <td>00</td> <td>2</td> <td>00</td> <td>DC bus thermal model gives trip with sub-trip 0</td> </tr> </tbody> </table> <p><b>Recommended actions:</b></p> <ul style="list-style-type: none"> <li>• Check the AC supply voltage balance and levels</li> <li>• Check DC bus ripple level</li> <li>• Reduce duty cycle</li> <li>• Reduce motor load</li> <li>• Check the output current stability. If unstable; <ul style="list-style-type: none"> <li>Check the motor map settings with motor nameplate (Pr <b>05.006</b>, Pr <b>05.007</b>, Pr <b>05.008</b>, Pr <b>05.009</b>, Pr <b>05.010</b>, Pr <b>05.011</b>)</li> <li>Disable slip compensation (Pr <b>05.027</b> = 0)</li> <li>Disable dynamic V to F operation (Pr <b>05.013</b> = 0)</li> <li>Select fixed boost (Pr <b>05.014</b> = Fixed)</li> <li>Select high stability space vector modulation (Pr <b>05.019</b> = 1)</li> <li>Disconnect the load and complete a rotating autotune (Pr <b>05.012</b>)</li> </ul> </li> </ul>	Source	xx	y	zz	Description	Control system	00	2	00	DC bus thermal model gives trip with sub-trip 0
Source	xx	y	zz	Description							
Control system	00	2	00	DC bus thermal model gives trip with sub-trip 0							
<b>Oht.C</b>	<b>Control stage over-temperature</b>										
219	<p>This trip indicates that a control stage over-temperature has been detected if Cooling Fan control (06.045) = 0.</p> <p>Recommended actions:</p> <p>Increase ventilation by setting Cooling Fan control (06.045) &gt; 0</p>										
<b>Oht.I</b>	<b>Inverter over temperature based on thermal model</b>										
21	<p>This trip indicates that an IGBT junction over-temperature has been detected based on a software thermal model.</p> <table border="1"> <thead> <tr> <th>Source</th> <th>xx</th> <th>y</th> <th>zz</th> <th>Description</th> </tr> </thead> <tbody> <tr> <td>Control system</td> <td>00</td> <td>1</td> <td>00</td> <td>Inverter thermal model gives {Oht.I} trip with sub-trip 0</td> </tr> </tbody> </table> <p><b>Recommended actions:</b></p> <ul style="list-style-type: none"> <li>• Reduce the selected drive switching frequency</li> <li>• Ensure <i>Auto-switching Frequency Change Disable</i> (05.035) is set to OFF</li> <li>• Reduce duty cycle</li> <li>• Increase acceleration / deceleration rates</li> <li>• Reduce motor load</li> <li>• Check DC bus ripple</li> <li>• Ensure all three input phases are present and balanced</li> </ul>	Source	xx	y	zz	Description	Control system	00	1	00	Inverter thermal model gives {Oht.I} trip with sub-trip 0
Source	xx	y	zz	Description							
Control system	00	1	00	Inverter thermal model gives {Oht.I} trip with sub-trip 0							
<b>Oht.P</b>	<b>Power stage over temperature</b>										
22	<p>This trip indicates that a power stage over-temperature has been detected. From the sub-trip 'xyzz', the Thermistor location is identified by 'zz'.</p> <table border="1"> <thead> <tr> <th>Source</th> <th>xx</th> <th>y</th> <th>zz</th> <th>Description</th> </tr> </thead> <tbody> <tr> <td>Power system</td> <td>01</td> <td>0</td> <td>zz</td> <td>Thermistor location in the drive defined by zz</td> </tr> </tbody> </table> <p><b>Recommended actions:</b></p> <ul style="list-style-type: none"> <li>• Check enclosure / drive fans are still functioning correctly</li> <li>• Force the heatsink fans to run at maximum speed</li> <li>• Check enclosure ventilation paths</li> <li>• Check enclosure door filters</li> <li>• Increase ventilation</li> <li>• Reduce the drive switching frequency</li> <li>• Reduce duty cycle</li> <li>• Increase acceleration / deceleration rates</li> <li>• Reduce motor load</li> <li>• Check the derating tables and confirm the drive is correctly sized for the application.</li> <li>• Use a drive with larger current / power rating</li> </ul>	Source	xx	y	zz	Description	Power system	01	0	zz	Thermistor location in the drive defined by zz
Source	xx	y	zz	Description							
Power system	01	0	zz	Thermistor location in the drive defined by zz							

Trip	Diagnosis										
<b>Oht.r</b>	<b>Rectifier over temperature</b>										
	The <i>Oht.r</i> trip indicates that a rectifier over-temperature has been detected. The thermistor location can be identified from the sub-trip number.										
	<table border="1"> <thead> <tr> <th>Source</th> <th>xx</th> <th>y</th> <th>zz</th> <th>Description</th> </tr> </thead> <tbody> <tr> <td>Power system</td> <td>Power module number</td> <td>Rectifier number</td> <td>zz</td> <td>Thermistor location defined by zz</td> </tr> </tbody> </table>	Source	xx	y	zz	Description	Power system	Power module number	Rectifier number	zz	Thermistor location defined by zz
Source	xx	y	zz	Description							
Power system	Power module number	Rectifier number	zz	Thermistor location defined by zz							
102	<p><b>Recommend actions:</b></p> <ul style="list-style-type: none"> <li>• Check the motor and motor cable insulation with an insulation tester</li> <li>• Fit an output line reactor or sinusoidal filter</li> <li>• Force the heatsink fans to run at maximum speed by setting Pr <b>06.045</b> = 1</li> <li>• Check enclosure / drive fans are still functioning correctly</li> <li>• Check enclosure ventilation paths</li> <li>• Check enclosure door filters</li> <li>• Increase ventilation</li> <li>• Increase acceleration / deceleration rates</li> <li>• Reduce duty cycle</li> <li>• Reduce motor load</li> </ul>										
<b>OI.A1</b>	<b>Analog input 1 over-current</b>										
189	Current input on analog input 1 exceeds 24mA.										
<b>OI.AC</b>	<b>Instantaneous output over current detected</b>										
	The instantaneous drive output current has exceeded VM_DRIVE_CURRENT_MAX.										
	<table border="1"> <thead> <tr> <th>Source</th> <th>xx</th> <th>y</th> <th>zz</th> <th>Description</th> </tr> </thead> <tbody> <tr> <td>Control system</td> <td>00</td> <td>0</td> <td>00</td> <td>Instantaneous over-current trip when the measured a.c. current exceeds VM_DRIVE_CURRENT[MAX].</td> </tr> </tbody> </table>	Source	xx	y	zz	Description	Control system	00	0	00	Instantaneous over-current trip when the measured a.c. current exceeds VM_DRIVE_CURRENT[MAX].
Source	xx	y	zz	Description							
Control system	00	0	00	Instantaneous over-current trip when the measured a.c. current exceeds VM_DRIVE_CURRENT[MAX].							
3	<p><b>Recommended actions/checks:</b></p> <ul style="list-style-type: none"> <li>• Increase acceleration/deceleration rate</li> <li>• If seen during autotune reduce the voltage boost</li> <li>• Check for short circuit on the output cabling</li> <li>• Check integrity of the motor insulation using an insulation tester</li> <li>• Is the motor cable length within limits for the frame size?</li> <li>• Reduce the values in the current loop gain parameters</li> </ul>										
<b>OI.br</b>	<b>Braking IGBT over current detected: short circuit protection for the braking IGBT activated</b>										
	The <i>OI.br</i> trip indicates that over current has been detected in braking IGBT or braking IGBT protection has been activated.										
	<table border="1"> <thead> <tr> <th>Source</th> <th>xx</th> <th>y</th> <th>zz</th> <th>Description</th> </tr> </thead> <tbody> <tr> <td>Power system</td> <td>01</td> <td>0</td> <td>00</td> <td>Braking IGBT instantaneous over-current trip</td> </tr> </tbody> </table>	Source	xx	y	zz	Description	Power system	01	0	00	Braking IGBT instantaneous over-current trip
Source	xx	y	zz	Description							
Power system	01	0	00	Braking IGBT instantaneous over-current trip							
4	<p><b>Recommended actions:</b></p> <ul style="list-style-type: none"> <li>• Check brake resistor wiring</li> <li>• Check braking resistor value is greater than or equal to the minimum resistance value</li> <li>• Check braking resistor insulation</li> </ul>										
<b>OI.dC</b>	<b>Power module over current detected from IGBT on state voltage monitoring</b>										
	The <i>OI.dC</i> trip indicates that the short circuit protection for the drive output stage has been activated.										
109	<p><b>Recommended actions:</b></p> <ul style="list-style-type: none"> <li>• Disconnect the motor cable at the drive end and check the motor and cable insulation with an insulation tester</li> <li>• Replace the drive</li> </ul>										

Trip	Diagnosis															
<b>OI.Sn</b>	<b>Snubber over-current detected</b>															
92	This trip indicates that an over-current condition has been detected in the rectifier snubbing circuit, The exact cause of the trip can be identified by the sub-trip number.															
	<table border="1"> <thead> <tr> <th>Source</th> <th>xx</th> <th>y</th> <th>zz</th> </tr> </thead> <tbody> <tr> <td>Power system</td> <td>01</td> <td>1</td> <td>00: Rectifier snubber over-current trip detected</td> </tr> </tbody> </table>	Source	xx	y	zz	Power system	01	1	00: Rectifier snubber over-current trip detected							
	Source	xx	y	zz												
Power system	01	1	00: Rectifier snubber over-current trip detected													
<p><b>Recommended actions:</b></p> <ul style="list-style-type: none"> <li>• Ensure the internal EMC filter is installed.</li> <li>• Ensure the motor cable length does not exceed the maximum for selected switching frequency.</li> <li>• Check for supply voltage imbalance.</li> <li>• Check for supply disturbance such as notching from a DC drive.</li> <li>• Check the motor and motor cable insulation with a Megger.</li> </ul> <p>Fit an output line reactor or sinusoidal filter.</p>																
<b>OI.SC</b>	<b>Output phase short-circuit</b>															
228	Over-current detected on drive output when enabled. Possible motor ground fault. Recommended actions: <ul style="list-style-type: none"> <li>• Check for short circuit on the output cabling</li> <li>• Check integrity of the motor insulation using an insulation tester</li> <li>• Is the motor cable length within limits for the frame size?</li> </ul>															
<b>Out.P</b>	<b>Output phase loss detected</b>															
98	The <i>Out.P</i> trip indicates that a phase loss has been detected at the drive output. If <i>Output Phase Loss Detection Enable</i> (06.059) = 1 then output phase loss is detected as follows: <ol style="list-style-type: none"> <li>1. When the drive is enabled short pulses are applied to make sure each output phase is connected.</li> <li>2. During running the output current is monitored and the output phase loss condition is detected if the current contains more than TBD % negative phase sequence current for TBDs.</li> </ol> <p><b>Recommended action:</b></p> <ul style="list-style-type: none"> <li>• Check motor and drive connections</li> <li>• To disable the trip set <i>Output Phase Loss Detection Enable</i> (06.059) = 0</li> </ul>															
<b>OV</b>	<b>DC bus voltage has exceeded the peak level or maximum continuous level for 15 seconds</b>															
2	The OV trip indicates that the DC bus voltage has exceeded the VM_DC_VOLTAGE[MAX] or VM_DC_VOLTAGE_SET[MAX] for 15 s. The trip threshold varies depending on voltage rating of the drive as shown below.															
	<table border="1"> <thead> <tr> <th>Voltage rating</th> <th>VM_DC_VOLTAGE[MAX]</th> <th>VM_DC_VOLTAGE_SET[MAX]</th> </tr> </thead> <tbody> <tr> <td>100</td> <td>415</td> <td>410</td> </tr> <tr> <td>200</td> <td>415</td> <td>410</td> </tr> <tr> <td>400</td> <td>830</td> <td>815</td> </tr> </tbody> </table>	Voltage rating	VM_DC_VOLTAGE[MAX]	VM_DC_VOLTAGE_SET[MAX]	100	415	410	200	415	410	400	830	815			
	Voltage rating	VM_DC_VOLTAGE[MAX]	VM_DC_VOLTAGE_SET[MAX]													
	100	415	410													
200	415	410														
400	830	815														
<b>Sub-trip Identification</b>																
<table border="1"> <thead> <tr> <th>Source</th> <th>xx</th> <th>y</th> <th>zz</th> </tr> </thead> <tbody> <tr> <td>Control system</td> <td>00</td> <td>0</td> <td>01: Instantaneous trip when the DC bus voltage exceeds VM_DC_VOLTAGE[MAX].</td> </tr> <tr> <td>Control system</td> <td>00</td> <td>0</td> <td>02: Time delayed trip indicating that the DC bus voltage is above VM_DC_VOLTAGE_SET[MAX].</td> </tr> <tr> <td>Power system</td> <td>01</td> <td>0</td> <td>00: Instantaneous trip when the DC bus voltage exceeds VM_DC_VOLTAGE[MAX].</td> </tr> </tbody> </table>	Source	xx	y	zz	Control system	00	0	01: Instantaneous trip when the DC bus voltage exceeds VM_DC_VOLTAGE[MAX].	Control system	00	0	02: Time delayed trip indicating that the DC bus voltage is above VM_DC_VOLTAGE_SET[MAX].	Power system	01	0	00: Instantaneous trip when the DC bus voltage exceeds VM_DC_VOLTAGE[MAX].
Source	xx	y	zz													
Control system	00	0	01: Instantaneous trip when the DC bus voltage exceeds VM_DC_VOLTAGE[MAX].													
Control system	00	0	02: Time delayed trip indicating that the DC bus voltage is above VM_DC_VOLTAGE_SET[MAX].													
Power system	01	0	00: Instantaneous trip when the DC bus voltage exceeds VM_DC_VOLTAGE[MAX].													
<p><b>Recommended actions:</b></p> <ul style="list-style-type: none"> <li>• Increase deceleration ramp (Pr <b>00.004</b>)</li> <li>• Decrease the braking resistor value (staying above the minimum value)</li> <li>• Check nominal AC supply level</li> <li>• Check for supply disturbances which could cause the DC bus to rise</li> <li>• Check motor insulation using a insulation tester</li> </ul>																

Trip	Diagnosis																																																							
<b>P.dAt</b>	<b>Power system configuration data error</b>																																																							
220	The <i>P.dAt</i> trip indicates that there is an error in the configuration data stored in the power system.																																																							
	<table border="1"> <thead> <tr> <th>Source</th> <th>xx</th> <th>y</th> <th>zz</th> <th>Description</th> </tr> </thead> <tbody> <tr> <td>Control system</td> <td>00</td> <td>0</td> <td>01</td> <td>No data was obtained from the power board.</td> </tr> <tr> <td>Control system</td> <td>00</td> <td>0</td> <td>02</td> <td>There is no data table in node 1.</td> </tr> <tr> <td>Control system</td> <td>00</td> <td>0</td> <td>03</td> <td>The power system data table is bigger than the space available in the control pod to store it.</td> </tr> <tr> <td>Control system</td> <td>00</td> <td>0</td> <td>04</td> <td>The size of the table given in the table is incorrect.</td> </tr> <tr> <td>Control system</td> <td>00</td> <td>0</td> <td>05</td> <td>Table CRC error.</td> </tr> <tr> <td>Control system</td> <td>00</td> <td>0</td> <td>06</td> <td>The version number of the generator software that produced the table is too low.</td> </tr> <tr> <td>Control system</td> <td>0</td> <td>0</td> <td>07</td> <td>The power data table failed to be stored in the power board.</td> </tr> <tr> <td>Power system</td> <td>01</td> <td>0</td> <td>00</td> <td>The power data table used internally by the power module has an error.</td> </tr> <tr> <td>Power system</td> <td>01</td> <td>0</td> <td>01</td> <td>The power data table that is uploaded to the control system on power up has an error.</td> </tr> <tr> <td>Power system</td> <td>01</td> <td>0</td> <td>02</td> <td>The power data table used internally by the power module does not match the hardware identification of the power module.</td> </tr> </tbody> </table>	Source	xx	y	zz	Description	Control system	00	0	01	No data was obtained from the power board.	Control system	00	0	02	There is no data table in node 1.	Control system	00	0	03	The power system data table is bigger than the space available in the control pod to store it.	Control system	00	0	04	The size of the table given in the table is incorrect.	Control system	00	0	05	Table CRC error.	Control system	00	0	06	The version number of the generator software that produced the table is too low.	Control system	0	0	07	The power data table failed to be stored in the power board.	Power system	01	0	00	The power data table used internally by the power module has an error.	Power system	01	0	01	The power data table that is uploaded to the control system on power up has an error.	Power system	01	0	02	The power data table used internally by the power module does not match the hardware identification of the power module.
	Source	xx	y	zz	Description																																																			
	Control system	00	0	01	No data was obtained from the power board.																																																			
	Control system	00	0	02	There is no data table in node 1.																																																			
	Control system	00	0	03	The power system data table is bigger than the space available in the control pod to store it.																																																			
	Control system	00	0	04	The size of the table given in the table is incorrect.																																																			
	Control system	00	0	05	Table CRC error.																																																			
	Control system	00	0	06	The version number of the generator software that produced the table is too low.																																																			
	Control system	0	0	07	The power data table failed to be stored in the power board.																																																			
	Power system	01	0	00	The power data table used internally by the power module has an error.																																																			
Power system	01	0	01	The power data table that is uploaded to the control system on power up has an error.																																																				
Power system	01	0	02	The power data table used internally by the power module does not match the hardware identification of the power module.																																																				
<b>Recommended actions:</b>																																																								
<ul style="list-style-type: none"> <li>Hardware fault – Contact the supplier of the drive</li> </ul>																																																								
<b>Pb.Er</b>	<b>Communication has been lost / errors detected between power control</b>																																																							
93	The <i>Pb.Er</i> trip is initiated if there is no communications between power control. The reason for the trip can be identified by the sub-trip number.																																																							
	<table border="1"> <thead> <tr> <th>Sub-trip</th> <th>Reason</th> </tr> </thead> <tbody> <tr> <td>1</td> <td>PLL operating region out of lock</td> </tr> <tr> <td>2</td> <td>Power board lost communication with user board</td> </tr> <tr> <td>3</td> <td>User board lost communication with power board</td> </tr> <tr> <td>4</td> <td>Communication CRC error</td> </tr> </tbody> </table>	Sub-trip	Reason	1	PLL operating region out of lock	2	Power board lost communication with user board	3	User board lost communication with power board	4	Communication CRC error																																													
	Sub-trip	Reason																																																						
	1	PLL operating region out of lock																																																						
	2	Power board lost communication with user board																																																						
3	User board lost communication with power board																																																							
4	Communication CRC error																																																							
<b>Recommended actions:</b>																																																								
<ul style="list-style-type: none"> <li>Hardware fault – Contact the supplier of the drive</li> </ul>																																																								
<b>Pb.HF</b>	<b>Power board HF</b>																																																							
235	Power processor hardware fault.																																																							
	<b>Recommended actions:</b>																																																							
<ul style="list-style-type: none"> <li>Hardware fault - Contact the supplier of the drive</li> </ul>																																																								
<b>Pd.S</b>	<b>Power down save error</b>																																																							
37	The <i>Pd.S</i> trip indicates that an error has been detected in the power down save parameters saved in non-volatile memory.																																																							
	<b>Recommended actions:</b>																																																							
<ul style="list-style-type: none"> <li>Perform a 1001 save in Pr <b>mm.000</b> to ensure that the trip doesn't occur the next time the drive is powered up.</li> </ul>																																																								

Trip	Diagnosis														
<b>PH.Lo</b>	<b>Supply phase loss</b>														
32	<p>The <i>PH.Lo</i> trip indicates that the drive has detected an input phase loss or large supply imbalance. The drive will attempt to stop the motor before this trip is initiated. If the motor cannot be stopped in 10 seconds the trip occurs immediately. The <i>PH.Lo</i> trip works by monitoring the ripple voltage on the DC bus of the drive, if the DC bus ripple exceeds the threshold, the drive will trip on PH.Lo. Potential causes of the DC bus ripple are input phase loss, Large supply impedance and severe output current instability.</p> <table border="1"> <thead> <tr> <th>Source</th> <th>xx</th> <th>y</th> <th>zz</th> </tr> </thead> <tbody> <tr> <td>Control system</td> <td>00</td> <td>0</td> <td>00: Phase loss detected based on control system feedback. The drive attempts to stop the drive before tripping unless bit 2 of <i>Action On Trip Detection</i> (10.037) is set to one.</td> </tr> </tbody> </table> <p>Input phase loss detection can be disabled when the drive is required to operate from the DC supply or from a single phase supply in <i>Input Phase Loss Detection Mode</i> (06.047).</p> <p><b>Recommended actions:</b></p> <ul style="list-style-type: none"> <li>• Check the AC supply voltage balance and level at full load</li> <li>• Check the DC bus ripple level with an isolated oscilloscope</li> <li>• Check the output current stability</li> <li>• Reduce the duty cycle</li> <li>• Reduce the motor load</li> <li>• Disable the phase loss detection, set Pr <b>06.047</b> to 2.</li> </ul>	Source	xx	y	zz	Control system	00	0	00: Phase loss detected based on control system feedback. The drive attempts to stop the drive before tripping unless bit 2 of <i>Action On Trip Detection</i> (10.037) is set to one.						
	Source	xx	y	zz											
	Control system	00	0	00: Phase loss detected based on control system feedback. The drive attempts to stop the drive before tripping unless bit 2 of <i>Action On Trip Detection</i> (10.037) is set to one.											
<b>PSU</b>	<b>Internal power supply fault</b>														
5	<p>The <i>PSU</i> trip indicates that one or more internal power supply rails are outside limits or overloaded.</p> <table border="1"> <thead> <tr> <th>Source</th> <th>xx</th> <th>y</th> <th>zz</th> <th>Description</th> </tr> </thead> <tbody> <tr> <td>Control system</td> <td>00</td> <td>0</td> <td rowspan="2">00</td> <td rowspan="2">Internal power supply overload.</td> </tr> <tr> <td>Power system</td> <td>01</td> <td>1</td> </tr> </tbody> </table> <p><b>Recommended actions:</b></p> <ul style="list-style-type: none"> <li>• There is a hardware fault within the drive – return the drive to the supplier</li> </ul>	Source	xx	y	zz	Description	Control system	00	0	00	Internal power supply overload.	Power system	01	1	
Source	xx	y	zz	Description											
Control system	00	0	00	Internal power supply overload.											
Power system	01	1													
<b>r.b.ht</b>	<b>Hot rectifier/brake</b>														
250	Over-temperature detected on input rectifier or braking IGBT.														
<b>Reserved</b>	<b>Reserved trips</b>														
14-17 11 09 01 94 - 95 103 - 108 191 - 198 168 - 173 238 - 245 23, 39, 99, 176, 205 - 214 223 - 224	<p>These trip numbers are reserved trip numbers for future use.</p> <table border="1"> <thead> <tr> <th>Trip Number</th> <th>Description</th> </tr> </thead> <tbody> <tr> <td>01</td> <td>Reserved resettable trip</td> </tr> <tr> <td>94 - 95</td> <td>Reserved resettable trip</td> </tr> <tr> <td>103 - 108</td> <td>Reserved resettable trip</td> </tr> <tr> <td>191 - 198</td> <td>Reserved resettable trip</td> </tr> <tr> <td>168 - 173</td> <td>Reserved resettable trip</td> </tr> <tr> <td>238 - 245</td> <td>Reserved non-resettable trip</td> </tr> </tbody> </table>	Trip Number	Description	01	Reserved resettable trip	94 - 95	Reserved resettable trip	103 - 108	Reserved resettable trip	191 - 198	Reserved resettable trip	168 - 173	Reserved resettable trip	238 - 245	Reserved non-resettable trip
Trip Number	Description														
01	Reserved resettable trip														
94 - 95	Reserved resettable trip														
103 - 108	Reserved resettable trip														
191 - 198	Reserved resettable trip														
168 - 173	Reserved resettable trip														
238 - 245	Reserved non-resettable trip														
<b>rS</b>	<b>Measured resistance has exceeded the parameter range</b>														
33	<p>The <i>rS</i> trip indicates that the measured stator resistance during an autotune test has exceeded the maximum possible value of <i>Stator Resistance</i> (05.017).</p> <p>The stationary autotune is initiated using the autotune function (Pr <b>05.012</b>) or in open loop vector mode (Pr <b>05.014</b>) on the first run command after power up in mode 4 (<i>Ur_I</i>) or on every run command in modes 0 (<i>Ur_S</i>) or 3 (<i>Ur_Auto</i>). This trip can occur if the motor is very small in comparison to the rating of the drive.</p> <p><b>Recommended actions:</b></p> <ul style="list-style-type: none"> <li>• Check the motor cable / connections</li> <li>• Check the integrity of the motor stator winding using a insulation tester</li> <li>• Check the motor phase to phase resistance at the drive terminals</li> <li>• Check the motor phase to phase resistance at the motor terminals</li> <li>• Ensure the stator resistance of the motor falls within the range of the drive model</li> <li>• Select fixed boost mode (Pr <b>05.014</b> = Fd) and verify the output current waveforms with an oscilloscope</li> <li>• Replace the motor</li> </ul>														

Trip	Diagnosis								
<b>So.St</b>	<b>Soft start relay failed to close, soft start monitor failed</b>								
	The <i>So.St</i> trip indicates that the soft start relay in the drive failed to close or the soft start monitoring circuit has failed. The cause of the trip can be identified by the sub-trip number.								
226	<table border="1"> <thead> <tr> <th>Sub-trip</th> <th>Reason</th> </tr> </thead> <tbody> <tr> <td>1</td> <td>Soft-start failure</td> </tr> <tr> <td>2</td> <td>DC bus capacitor failure on 110 V drive</td> </tr> </tbody> </table> <p><b>Recommended actions:</b></p> <ul style="list-style-type: none"> <li>Hardware fault – Contact the supplier of the drive</li> </ul>	Sub-trip	Reason	1	Soft-start failure	2	DC bus capacitor failure on 110 V drive		
Sub-trip	Reason								
1	Soft-start failure								
2	DC bus capacitor failure on 110 V drive								
<b>St.HF</b>	<b>Hardware trip has occurred during last power down</b>								
	The <i>St.HF</i> trip indicates that a hardware trip (HF01 –HF19) has occurred and the drive has been power cycled. The sub-trip number identifies the HF trip i.e. stored HF.19.								
221	<p><b>Recommended actions:</b></p> <ul style="list-style-type: none"> <li>Enter 1299 in Pr <b>mm.000</b> and press reset to clear the trip</li> </ul>								
<b>th.br</b>	<b>Brake resistor over temperature</b>								
	The <i>th.br</i> trip is initiated if the hardware based braking resistor thermal monitoring is connected and the resistor overheats. If the braking resistor is not used, then this trip must be disabled with bit 3 of <i>Action On Trip Detection</i> (10.037) to prevent this trip.								
10	<p><b>Recommended actions:</b></p> <ul style="list-style-type: none"> <li>Check brake resistor wiring</li> <li>Check braking resistor value is greater than or equal to the minimum resistance value</li> <li>Check braking resistor insulation</li> </ul>								
<b>th.Fb</b>	<b>Internal thermistor has failed</b>								
	The <i>th.Fb</i> trip indicates that an internal thermistor has failed. The thermistor location can be identified by the sub-trip number.								
218	<table border="1"> <thead> <tr> <th>Source</th> <th>xx</th> <th>y</th> <th>zz</th> </tr> </thead> <tbody> <tr> <td>Power system</td> <td>01</td> <td>0</td> <td>Thermistor location defined by zz</td> </tr> </tbody> </table> <p><b>Recommended actions:</b></p> <ul style="list-style-type: none"> <li>Hardware fault – Contact the supplier of the drive</li> </ul>	Source	xx	y	zz	Power system	01	0	Thermistor location defined by zz
Source	xx	y	zz						
Power system	01	0	Thermistor location defined by zz						
<b>tun.S</b>	<b>Autotune test stopped before completion</b>								
	The drive was prevented from completing an autotune test, because either the drive enable or the drive run were removed.								
18	<p><b>Recommended actions:</b></p> <ul style="list-style-type: none"> <li>Check the drive enable signal (Terminal 11) was active during the autotune</li> </ul>								
<b>U.OI</b>	<b>User OI ac</b>								
8	The U.OI trip is initiated if the output current of the drive exceeds the trip level set by <i>User Over Current Trip Level</i> (04.041).								
<b>U.S</b>	<b>User Save error / not completed</b>								
	The <i>U.S</i> trip indicates that an error has been detected in the user save parameters saved in non-volatile memory. For example, following a user save command, If the power to the drive was removed when the user parameters were being saved.								
36	<p><b>Recommended actions:</b></p> <ul style="list-style-type: none"> <li>Perform a user save in Pr <b>mm.000</b> to ensure that the trip doesn't occur the next time the drive is powered up.</li> <li>Ensure that the drive has enough time to complete the save before removing the power to the drive.</li> </ul>								
<b>US.24</b>	<b>User 24 V supply is not present on the adaptor interface terminals (1,2)</b>								
	A <i>US.24</i> trip is initiated if the <i>User Supply Select</i> (06.072), is set to 1 and no user 24 V supply is present on the user 24 V input on the AI-Backup adaptor.								
91	<p><b>Recommended actions:</b></p> <ul style="list-style-type: none"> <li>Ensure the user 24 V supply is present on the user terminals on the adaptor interface.</li> </ul>								



The trips can be grouped into the following categories. It should be noted that a trip can only occur when the drive is not tripped or is already tripped but with a trip with a lower priority number.

**Table 12-3 Trip categories**

Priority	Category	Trips	Comments
1	Internal faults	HF01, HF02, HF03, HF04, HF05, HF06, HF07, HF08, HF09, HF10, HF11, HF12, HF13, HF14, HF15, HF16, HF17, HF18, HF19.	These indicate internal problems and cannot be reset. All drive features are inactive after any of these trips occur.
1	Stored HF trip	{St.HF}	This trip cannot be cleared unless 1299 is entered into <i>Parameter (mm.000)</i> and a reset is initiated.
2	Non-resettable trips	Trip numbers 218 to 247, {Sl.HF}	These trips cannot be reset.
3	Volatile memory failure	{EEF}	This can only be reset if Parameter <b>mm.000</b> is set to 1233 or 1244, or if <i>Load Defaults (11.043)</i> is set to a non-zero value.
4	NV Media Card trips	Trip numbers 174, 175 and 177 to 188	These trips are priority 5 during power-up.
4	Internal 24V	{PSU}	
5	Trips with extended reset times	{Ol.AC}, {Ol.br}, and {Ol.dc}, Fan.f.	These trips cannot be reset until 10 s after the trip was initiated.
5	Phase loss and d.c. jumper power circuit protection	{PH.Lo} and {Oh.dc}	The drive will attempt to stop the motor before tripping if a {PH.Lo}. 000 trip occurs unless this feature has been disabled (see <i>Action On Trip Detection (10.037)</i> ). The drive will always attempt to stop the motor before tripping if an {Oh.dc} occurs.
5	Standard trips	All other trips	

## 12.5 Internal / Hardware trips

Trips {HF01} to {HF19} are internal faults that do not have trip numbers. If one of these trips occurs, the main drive processor has detected an irrecoverable error. All drive functions are stopped and the trip message will be displayed on the drive keypad. If a non permanent trip occurs this may be reset by power cycling the drive. On power up after it has been power cycled the drive will trip on St.HF. Enter 1299 in **mm.000** to clear the Stored HF trip.

## 12.6 Alarm indications

In any mode, an alarm is an indication given on the display by alternating the alarm string with the drive status string display. If an action is not taken to eliminate any alarm except "tuning and LS" the drive may eventually trip. Alarms are not displayed when a parameter is being edited.

**Table 12-4 Alarm indications**

Alarm string	Description
<b>br.res</b>	Brake resistor overload. <i>Braking Resistor Thermal Accumulator (10.039)</i> in the drive has reached 75.0 % of the value at which the drive will trip.
<b>OV.Ld</b>	<i>Motor Protection Accumulator (04.019)</i> in the drive has reached 75.0 % of the value at which the drive will trip and the load on the drive is >100 %.
<b>d.OV.Ld</b>	Drive over temperature. <i>Percentage Of Drive Thermal Trip Level (07.036)</i> in the drive is greater than 90 %.
<b>tuning</b>	The autotune procedure has been initialized and an autotune in progress.
<b>LS</b>	Limit switch active. Indicates that a limit switch is active and that is causing the motor to be stopped.
<b>Lo.AC</b>	Low voltage mode. See <i>Low AC Alarm (10.107)</i> .
<b>I.AC.Lt</b>	Current limit active. See <i>Current Limit Active (10.009)</i> .

## 12.7 Status indications

**Table 12-5 Status indications**

String	Description	Drive output stage
<b>inh</b>	The drive is inhibited and cannot be run. Either the drive enable signal is not applied to the drive enable terminals or Pr <b>06.015</b> is set to 0.	Disabled
<b>rdy</b>	The drive is ready to run. The drive enable is active, but the drive inverter is not active because the final drive run is not active.	Disabled
<b>Stop</b>	The drive is stopped / holding zero speed.	Enabled
<b>S.Loss</b>	Supply loss condition has been detected.	Enabled
<b>dc.inj</b>	The drive is applying dc injection braking.	Enabled
<b>Er</b>	The drive has tripped and no longer controlling the motor. The trip code appears in the display.	Disabled
<b>UV</b>	The drive is in the under voltage state either in low voltage or high voltage mode.	Disabled

**Table 12-6 Status indications at power-up**

String	Status
<b>PS.LOAD</b>	Waiting for power stage
The drive is waiting for the processor in the power stage to respond after power-up	

## 12.8 Displaying the trip history

The drive retains a log of the last ten trips that have occurred. *Trip 0* (10.020) to *Trip 9* (10.029) store the most recent 10 trips that have occurred where *Trip 0* (10.020) is the most recent and *Trip 9* (10.029) is the oldest. When a new trip occurs it is written to *Trip 0* (10.020) and all the other trips move down the log, with oldest being lost. The date and time when each trip occurs are also stored in the date and time log, i.e. *Trip 0 Date* (10.041) to *Trip 9 Time* (10.060). The date and time are taken from *Date* (06.016) and *Time* (06.017). Some trips have sub-trip numbers which give more detail about the reason for the trip. If a trip has a sub-trip number its value is stored in the sub-trip log, i.e. *Trip 0 Sub-trip Number* (10.070) to *Trip 9 Sub-trip Number* (10.079). If the trip does not have a sub-trip number then zero is stored in the sub-trip log.

### NOTE

The trip logs can be reset by writing a value of 255 in Pr **10.038**.

## 12.9 Behavior of the drive when tripped

If the drive trips, the output of the drive is disabled so the load coasts to a stop. If any trip occurs, the following read only parameters are frozen until the trip is cleared. This is to help diagnose the cause of the trip.

Parameter	Description
<b>01.001</b>	Frequency reference
<b>01.002</b>	Pre-skip filter reference
<b>01.003</b>	Pre-ramp reference
<b>02.001</b>	Post-ramp reference
<b>03.001</b>	Final demand ref
<b>04.001</b>	Current magnitude
<b>04.002</b>	Active current
<b>04.017</b>	Reactive current
<b>05.001</b>	Output frequency
<b>05.002</b>	Output voltage
<b>05.003</b>	Power
<b>05.005</b>	DC bus voltage
<b>07.001</b>	Analog input 1
<b>07.037</b>	Temperature nearest to trip level

If the parameters are not required to be frozen then this can be disabled by setting bit 4 of Pr **10.037**.

## 13 UL Listing

### 13.1 General

Drive sizes 1 to 4 have been assessed to meet both UL and cUL requirements.

UL listings can be viewed online at [www.UL.com](http://www.UL.com). The UL file number is E171230.

### 13.2 Mounting

Drives can be installed in the following configurations:

- Standard or surface mounted. This is described in section 3.5.1 *Surface mounting* on page 20.
- Bookcase mounted. Drives are mounted side by side with no space between them. This configuration minimizes the overall width of the installation.

### 13.3 Environment

Drives are able to meet the following UL/NEMA environmental ratings:

- Type 1. The drive must either be installed with a UL Type 1 kit or be installed in a Type 1 enclosure.
- Type 12. The drive must be installed in a Type 12 enclosure.
- The remote keypad is rated to both UL Type 1 and UL Type 12.
- Drives must be installed in a pollution degree 2 environment or better.

### 13.4 Electrical installation

The following precautions must be observed:

- Drives are rated for use at 40 °C and 50 °C surrounding air temperature.
- The temperature rating of the power cables must be at least 75 °C.
- If the drive control stage is powered from an external power supply (+24 V), the power supply must be listed or recognized to UL class 2 with appropriate fusing.
- Ground connections must use UL listed closed loop (ring) terminals.

### 13.5 UL listed accessories

The following options are UL listed:

- CI-Keypad
- CI-485 Adaptor
- AI-485 Adaptor
- AI-Backup Adaptor
- Remote Keypad
- UL Type 1 kit
- NV Media card

### 13.6 Motor overload protection

The drives are installed with solid state motor overload protection.

The default overload protection level is less than 150 % of full load rated current for open loop operation.

The default overload protection level is less than 180 % of full load rated current for rotor flux control operation.

In order for the motor protection to work correctly, the motor rated current must be entered into Pr **00.006** or Pr **05.007**.

The protection level may be adjusted below 150 % if required. See section 8.3 *Current limits* on page 65.

### 13.7 Motor overspeed protection

The drive is installed with solid state motor overspeed protection.

However, this feature does not provide the level of protection provided by an independent, high-integrity overspeed protection device.

### 13.8 Thermal memory retention

Drives incorporate thermal memory retention that complies fully with the requirements of UL508C.

The drive is provided with motor load and speed sensitive overload protection with thermal memory retention that complies with the US National Electrical Code (NFPA 70) clause 430.126 and Underwriters Laboratories Standard UL508C, clause 20.1.11 (a). The purpose of this protection is to protect both drive and motor from dangerous overheating in the event of repeated overload or failure to start, even if the power to the drive is removed between overload events.

For full explanation of the thermal protection system, refer to section 8.4 *Motor thermal protection* on page 65.

In order to comply with UL requirements for thermal memory retention, it is necessary to set the *Thermal Protection Mode* (04.016) to zero; and the *Low Frequency Thermal Protection Mode* (04.025) must be set to 1 if the drive is operated in Heavy Duty mode.

Alternatively, an external thermal sensor or switch may be used as a means of motor and drive overload protection that complies with the requirements of UL508C, clause 20.1.11 (b). This protection method is particularly recommended where independent forced cooling of the motor is used, because of the risk of overheating if the cooling is lost.

#### External thermal sensor

The drive is provided with a means to accept and act upon a signal from a thermal sensor or switch imbedded in the motor or from an external protective relay. Refer to section 4.8.2 *Control terminal specification* on page 48.

### 13.9 Electrical ratings

- Drives are listed for connection to an AC supply capable of delivering no more than 100 kA symmetrical amperes. See Table 4-2
- Power and current ratings are given in Table 11-1 to Table 11-2.
- Fuse and circuit breaker (size 1 only with short circuit rating of 10 kA. Only the listed DIVQ/DIVQ7 type SU203UP ABB (E212323) circuit breaker may be used) ratings are given in Table 4-3 to Table 4-5.
- Unless indicated otherwise in Table 4-3 to Table 4-5, fuses may be any UL listed Class J or CC with a voltage rating of at least 600 Vac.
- Unless indicated otherwise in Table 4-3 to Table 4-5, circuit breakers may be any UL listed type, category control number: DIVQ or DIVQ7, with a voltage rating of at least 600 Vac.

### 13.10 cUL requirements for frame size 4

For frame size 4, models Mxxx-042 00133A, Mxxx-042 00176A, Mxxx-044 00135A and Mxxx-044 00170A, transient surge suppression shall be installed on the line side of this equipment and shall be rated 480 Vac (phase to ground), 480 Vac (phase to phase), suitable for overvoltage category III, and shall provide protection for a rated impulse withstand voltage peak of 6 kV and a clamping voltage of maximum 2400 V.

#### NOTE

Mxxx denotes M100, M101, M200, M201, M300 or M400.

### 13.11 Group installation

#### 13.11.1 Definition

Group Installation Definition: A motor branch circuit for two or more motors, or one or more motors with other loads, protected by a circuit breaker or a single set of fuses.

#### 13.11.2 Limitations on use

##### All motors rated less than 1 hp

The drives may be used in group installations where each of the motors is rated 1 hp or less. The full-load current rating of each motor must not exceed 6 A. The motor drive provides individual overload protection in accordance with the NEC clause 430.32.

**Smallest motor protected**

The drives may be used in group installations where the smallest motor is protected by the branch fuses or circuit breaker. Limits on the current rating of branch circuit protective fuses and circuit breakers are given in the NEC Table: 430.52.

**Other installations**

The motor drives described in this user guide are not UL listed for group installation.

---

# Index

---

## A

AC supply contactor .....	36
AC supply requirements .....	33
Acceleration .....	61
Access .....	17
Accuracy .....	108
Acoustic noise .....	108
Advanced menus .....	53
Advanced parameters .....	69
Air-flow in a ventilated enclosure .....	24
Alarm .....	129
Alarm Indications .....	129
Altitude .....	107
Autotune .....	63

## B

Basic requirements .....	59
Braking .....	39
Braking resistor values .....	113

## C

Cable clearances .....	44
Cable lengths (maximum) .....	111
Cable size ratings .....	109
Cable types and lengths .....	36
Cautions .....	7
Compliance with EN 61800-3:2004 .....	44
Control connections .....	47
Control terminal specification .....	48
Cooling .....	17
Cooling method .....	107
Current limits .....	65
Current ratings .....	103

## D

DC bus voltage .....	39
Deceleration .....	39, 61
Defaults (restoring parameter) .....	53
Derating .....	103
Destination parameter .....	47
Diagnostics .....	116
Dimensions (overall) .....	108
Display .....	50
Display messages .....	53

## E

Electrical safety .....	17
Electrical terminals .....	28
Electromagnetic compatibility (EMC) .....	18, 41, 113
EMC - Compliance with generic emission standards .....	44
EMC - General requirements .....	42
EMC - Variations in the wiring .....	45
EMC filter dimensions (external, overall) .....	115
EMC filter torque settings (external) .....	115
EMC filters (optional external) .....	114
Emission .....	114
Enclosure .....	22
Enclosure Layout .....	23
Enclosure sizing .....	24
Environmental protection .....	17
External EMC filter .....	25

## F

Field weakening (constant power) operation .....	65
Fire protection .....	17
Fixed V/F mode .....	12
Fuse ratings .....	109
Fuse types .....	36

## G

Getting Started .....	50
Ground connections .....	36, 43
Ground leakage .....	40
Ground terminals .....	28
Grounding bracket .....	41

## H

Hazardous areas .....	18
Humidity .....	107

## I

Input inductor calculation .....	33
Internal EMC filter .....	41
IP Rating (Ingress protection) .....	107
Isolator switch .....	46
Items supplied with the drive .....	16

## K

Keypad .....	50
--------------	----

## L

Line reactors .....	33, 107
---------------------	---------

<b>M</b>		<b>R</b>	
Mechanical Installation .....	17	Ratings .....	33
Menu 0 .....	52	Reactor current ratings .....	33, 107
Menu 01 - Frequency / speed reference .....	76	Relay contacts .....	49
Menu 02 - Ramps .....	80	Residual current device (RCD) .....	40
Menu 03 - Slave frequency, speed feedback and speed control .....	83	Resistances (minimum) .....	39
Menu 04 - Torque and current control .....	85	Resolution .....	108
Menu 05 - Motor control .....	87	Routine maintenance .....	29
Menu 06 - Sequencer and clock .....	90	<b>S</b>	
Menu 07 - Analog I/O .....	92	Safety Information .....	7, 17
Menu 08 - Digital I/O .....	94	Saving parameters .....	53
Menu 10 - Status and trips .....	98	Sealed enclosure - sizing .....	24
Menu 11 - General drive set-up .....	100	Single line descriptions .....	55
Menu 22 - Additional Menu 0 set-up .....	101	Speed range .....	108
Menu structure .....	52	Start up time .....	108
Minimum connections to get the motor running in any operating mode .....	60	Starts per hour .....	108
Mode parameter .....	47	Status .....	130
Motor (running the motor) .....	59	Status Indications .....	130
Motor cable - interruptions .....	46	Storage .....	107
Motor isolator / disconnect-switch .....	46	Supply requirements .....	107
Motor number of poles .....	62	Supply types .....	33
Motor operation .....	38	Surface mounting the drive .....	20
Motor rated current .....	62	Surge immunity of control circuits - long cables and connections outside a building .....	46
Motor rated current (maximum) .....	65	Surge suppression for analog and bipolar inputs and outputs .....	47
Motor rated frequency .....	62	Surge suppression for digital and unipolar inputs and outputs .....	47
Motor rated power factor .....	62	Switching frequency .....	65
Motor rated speed .....	62	<b>T</b>	
Motor rated voltage .....	62	Technical data .....	103
Motor requirements .....	107	Temperature .....	107
Motor thermal protection .....	65	Terminal block in the enclosure .....	46
Motor winding voltage .....	37	Terminal cover removal .....	18
Multiple motors .....	38	Terminal sizes .....	28
<b>N</b>		Thermal protection circuit for the braking resistor .....	40
NEMA rating .....	108	Torque settings .....	28, 113
Notes .....	7	Trip .....	116
<b>O</b>		Trip History .....	130
Open loop mode .....	12	Trip Indications .....	116
Open loop vector mode .....	12	<b>U</b>	
Operating modes .....	12	User Security .....	54
Optimization .....	62	<b>V</b>	
Options .....	15	Ventilation .....	22
Output contactor .....	38	Vibration .....	108
Output frequency .....	108	Voltage mode .....	63, 64
<b>P</b>		<b>W</b>	
Parameter access level .....	54	Warnings .....	7
Parameter ranges .....	70	Weights .....	109
Parameter security .....	54		
Planning the installation .....	17		
Power ratings .....	39, 103		
Power terminals .....	28		
Product information .....	9		
<b>Q</b>			
Quick start commissioning / Start-up .....	61		
Quick start connections .....	59		



**0478-0041-03**