

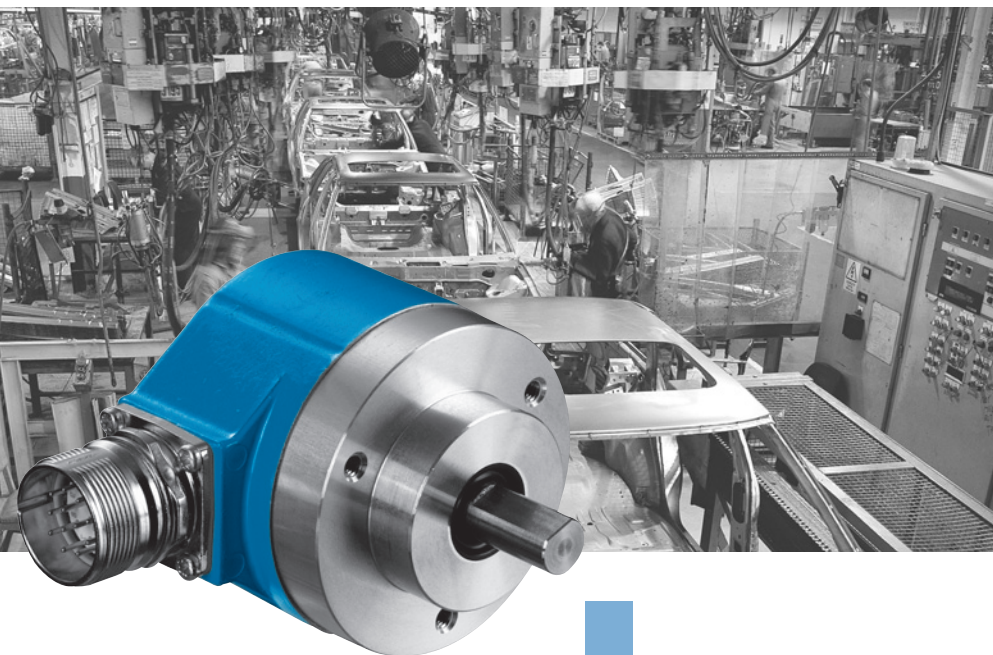

# DGS60, DGS65 and DGS66: Incremental Encoders for rough environmental conditions



Select your individual encoder!  
Possible product variants:  
6 and 10 mm solid shafts with servo flange or face mount flange, through or blind hollow shafts with connector or cable outlet, TTL or HTL interface.

Thanks to this wide variety of products, there are numerous possible uses, for example in:

- machine tools
- textile machines
- woodworking machines
- packaging machines

	<b>Number of lines 100 to 10,000</b>
<b>Incremental Encoder</b>	

Incremental encoders in the DGS60, DGS65 and DGS66 series are in use world-wide under the toughest environmental conditions.

The rugged construction – up to IP 67 degree protection – and the individual adaptation of the design to the requirements of the user are the outstanding features of this series.

Resolutions up to 10,000 lines are available.



**Number of lines**  
**100 to 10,000**

Incremental Encoder

- Servo or face mount flange
- Connector or cable outlet
- Protection class up to IP 67
- Electrical Interfaces  
TTL and HTL

## Dimensional drawing servo flange

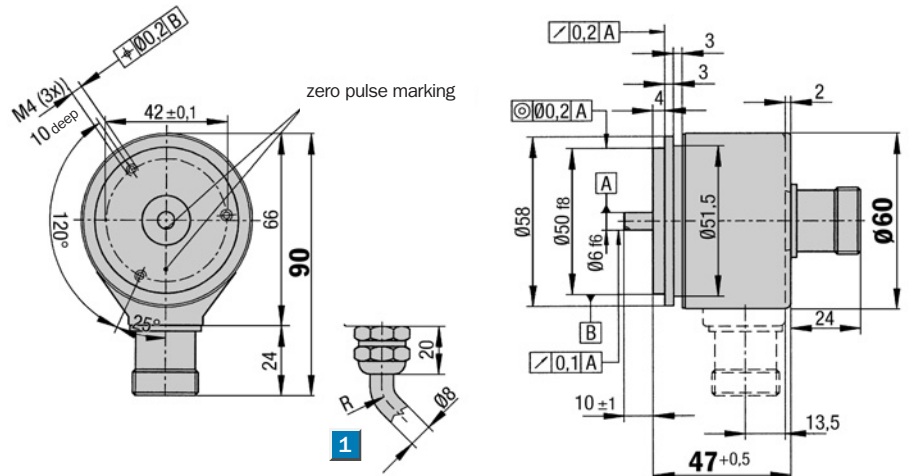

1 R = bending radius min. 40 mm

General tolerances according to DIN ISO 2768-mk

## Dimensional drawing face mount flange

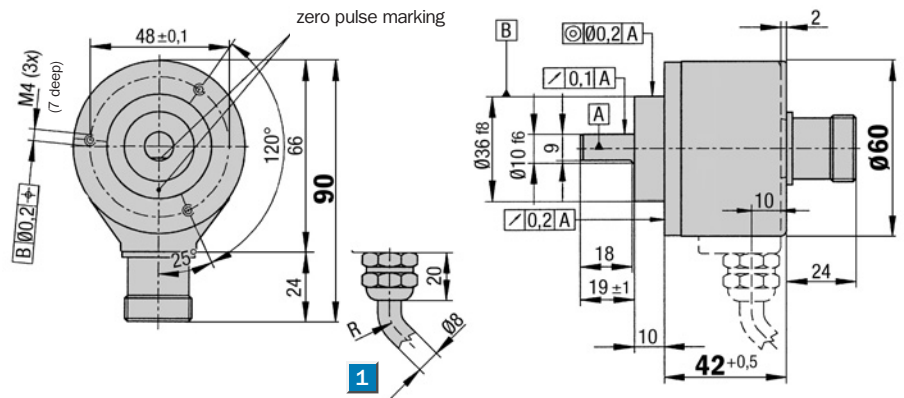

1 R = bending radius min. 40 mm

General tolerances according to DIN ISO 2768-mk

## PIN and wire allocation/cable 11 core

PIN	Signal HTL	Signal TTL	Core colour (cable outlet)	Explanation
1	N. C.	$\bar{B}$	black	Signal line
2	N. C.	Sense +	grey	Connected internally to $U_s$
3	Z	Z	lilac	Signal line
4	N. C.	$\bar{Z}$	yellow	Signal line
5	A	A	white	Signal line
6	N. C.	$\bar{A}$	brown	Signal line
7	N. C.	N. C.	orange	N. C.
8	B	B	pink	Signal line
9	Screen	Screen		Housing potential
10	GND	GND	blue	Ground connection
11	N. C.	Sense -	green	Connected internally to ground
12	$U_s$	$U_s$	red	Power supply <sup>1)</sup>

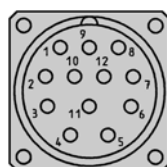

View of the connector M23 fitted to the encoder body

<sup>1)</sup> Potential free to housing

N. C. = Not Connected



### Accessories

- Connection systems
- Mounting systems

Technical Data to DIN 32878		DGS60		Flange type							
		servo	face m.								
<b>Solid shaft</b>	10 mm										
	6 mm										
<b>Number of lines (Z) per revolution</b>	00100 to 10,000, see order info										
<b>Electrical Interface</b>	TTL/RS 422, 6-channel										
	HTL/push-pull, 3-channel (A, B, Z)										
<b>Mass <sup>4)</sup></b>	Approx. 0.3 kg										
<b>Moment of inertia of the rotor</b>											
Servo flange	13 gcm <sup>2</sup>										
Face mount flange	25 gcm <sup>2</sup>										
<b>Measuring step</b>	90°/number of lines										
<b>Reference signal</b>											
Number	1										
Position	90° electr. & logically interlocked with A+B										
<b>Error limits</b>											
100 ≤ Z < 1250	45/Z + 0.054°										
1250 < Z ≤ 10000	45/Z + 0.039°										
<b>Measuring step deviation</b>	45/Z °										
<b>Max. output frequency</b>											
TTL	300 kHz (600 at > 5000 lines)										
HTL	200 kHz										
<b>Max. operating speed <sup>2)</sup></b>											
with shaft seal	6,000 min <sup>-1</sup>										
without shaft seal	10,000 min <sup>-1</sup>										
<b>Max. angular acceleration</b>	5 x 10 <sup>5</sup> rad/s <sup>2</sup>										
<b>Operating torque</b>											
with shaft seal	1 Ncm										
without shaft seal	0.1 Ncm										
<b>Start up torque</b>											
with shaft seal	1.5 Ncm										
without shaft seal	0.2 Ncm										
<b>Permissible shaft loading</b>											
Servo flange radial/axial	20 N/10 N										
Face mount flange radial/axial	40 N/20 N										
<b>Bearing lifetime</b>	3.6 x 10 <sup>10</sup> revolutions										
<b>Working temperature range</b>	- 20 ... + 85 °C										
<b>Storage temperature range</b>	- 30 ... + 85 °C										
<b>Permissible relative humidity <sup>3)</sup></b>	90 %										
<b>EMC <sup>4)</sup></b>											
<b>Resistance</b>											
to shocks <sup>5)</sup>	30/11 g/ms										
to vibration <sup>6)</sup>	20/10 ... 2000 g/Hz										
<b>Protection class acc. IEC 60529</b>											
Connector outlet <sup>7)</sup>	IP 67										
Cable outlet	IP 65										
<b>Operating voltage range</b>											
Load current TTL/RS 422, 4 ... 6 V	Max. 20 mA										
TTL/RS 422, 10 ... 30 V	Max. 20 mA										
HTL/push-pull, 10 ... 30 V	Max. 60 mA										
<b>Operating current range at no load</b>											
at 24 V	100 mA										
at 5 V	120 mA										

<sup>4)</sup> For an encoder with connector outlet

<sup>3)</sup> Condensation not permitted

<sup>5)</sup> To DIN EN 60068-2-27

<sup>2)</sup> At speeds > 6000 rpm the shaft seal must be removed

<sup>4)</sup> To DIN EN 61000-6-2 and DIN EN 61000-6-3

<sup>6)</sup> To DIN EN 60068-2-6

<sup>7)</sup> With mating connector fitted

 **Number of lines**  
**100 to 10,000**

**Incremental Encoder**

- Servo or face mount flange
- Connector or cable outlet
- Protection class up to IP 67
- Electrical Interfaces  
TTL and HTL

## Incremental pulse diagram

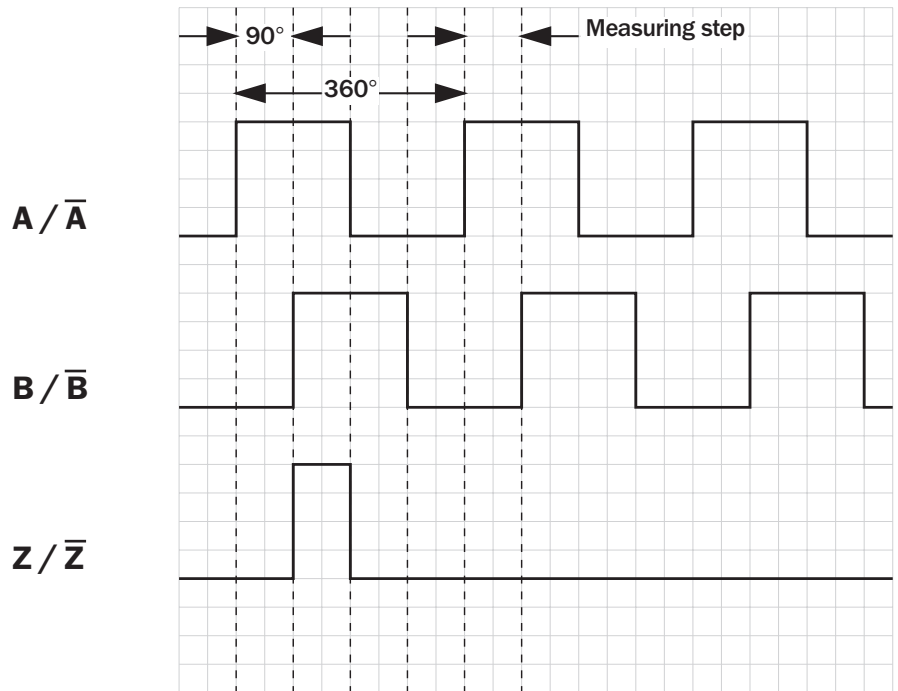

## Electrical interfaces

Supply voltage	4 ... 6 V	10 ... 30 V	10 ... 30 V
Interfaces/drivers	TTL (RS 422)	TTL (RS 422)	HTL (push-pull)

## Connection type

Cable radial	Cable axial	Connector radial	Connector axial
--------------	-------------	------------------	-----------------

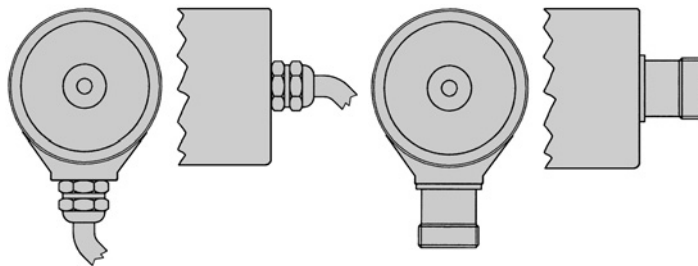

## Accessories

- Connection systems
- Mounting systems

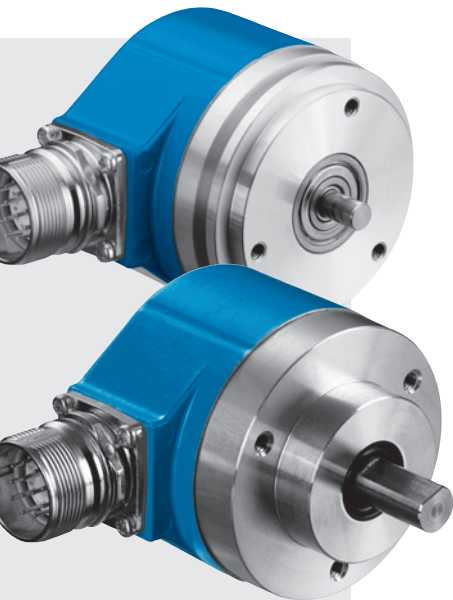

**Order information**

**Incremental Encoder DGS60, solid shaft**

Point 1	Point 2	Point 3	Point 4	Point 5	Point 6	Point 7	Point 8	Point 9	Point 10	Point 11	Point 12	Point 13	Point 14
<b>D</b>	<b>G</b>	<b>S</b>	<b>6</b>	<b>0</b>	<b>-</b>								

Electrical interface	
4 ... 6 V, TTL (RS 422) = <b>A</b>	
10 ... 30 V, TTL (RS 422) = <b>C</b>	
10 ... 30 V, HTL (push-pull) = <b>G</b>	

Mechanical interface	
Servo flange, shaft 6 mm = <b>1</b>	
Face mount flange, shaft 10 mm = <b>4</b>	

Connection type	
Connector M23, 12 pin, radial = <b>A</b>	
Connector M23, 12 pin, axial = <b>B</b>	
Cable 11 core, radial 1.5 m = <b>K</b>	
Cable 11 core, radial 3 m = <b>L</b>	
Cable 11 core, radial 5 m = <b>M</b>	
Cable 11 core, axial 1.5 m = <b>R</b>	
Cable 11 core, axial 3 m = <b>S</b>	
Cable 11 core, axial 5 m = <b>T</b>	

Number of lines	
Always 5 characters in clear text	<b>1</b>

**1 Number of lines (Z) per revolution**

00100	00250	00500	00720	01024	02000	04000	07200
00125	00256	00512	00750	01200	02048	04096	08000
00150	00300	00570	00800	01250	02500	04500	08192
00160	00314	00600	00900	01500	03000	05000	09000
00180	00360	00625	01000	01800	03600	06000	10000
00200	00400	00700					

**Order example: Incremental Encoder DGS60**

**4 ... 6 V, TTL; servo flange; connector M23, 12 pin, radial; number of lines: 360**

Point 1	Point 2	Point 3	Point 4	Point 5	Point 6	Point 7	Point 8	Point 9	Point 10	Point 11	Point 12	Point 13	Point 14
<b>D</b>	<b>G</b>	<b>S</b>	<b>6</b>	<b>0</b>	<b>-</b>	<b>A</b>	<b>1</b>	<b>A</b>	<b>0</b>	<b>0</b>	<b>3</b>	<b>6</b>	<b>0</b>

**Please enter your individual encoder here**

Point 1	Point 2	Point 3	Point 4	Point 5	Point 6	Point 7	Point 8	Point 9	Point 10	Point 11	Point 12	Point 13	Point 14
<b>D</b>	<b>G</b>	<b>S</b>	<b>6</b>	<b>0</b>	<b>-</b>								

Point 1	Point 2	Point 3	Point 4	Point 5	Point 6	Point 7	Point 8	Point 9	Point 10	Point 11	Point 12	Point 13	Point 14
<b>D</b>	<b>G</b>	<b>S</b>	<b>6</b>	<b>0</b>	<b>-</b>								

Point 1	Point 2	Point 3	Point 4	Point 5	Point 6	Point 7	Point 8	Point 9	Point 10	Point 11	Point 12	Point 13	Point 14
<b>D</b>	<b>G</b>	<b>S</b>	<b>6</b>	<b>0</b>	<b>-</b>								

**Number of lines**  
**100 to 10,000**

Incremental Encoder

- Collets for shaft diameter 6, 8, 10, 11, 12 mm and 3/8"
- Connector or cable outlet
- Electrical Interfaces  
TTL and HTL

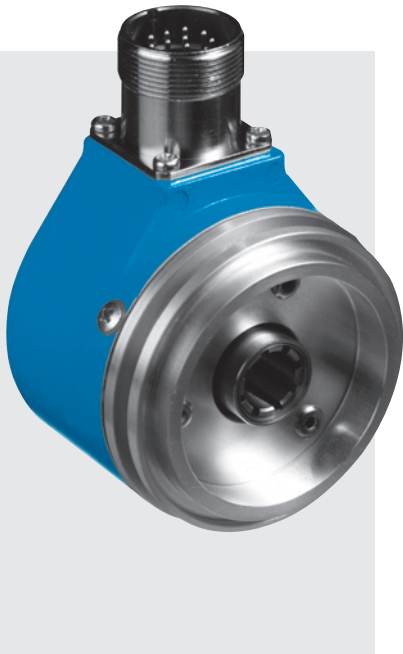

## Dimensional drawing blind hollow shaft

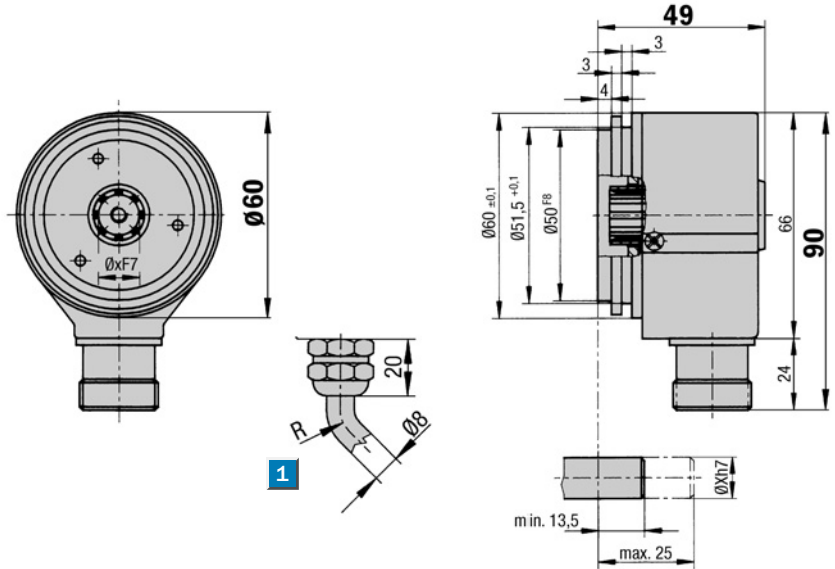

**1** R = bending radius min. 40 mm

General tolerances according to DIN ISO 2768-mk

## PIN and wire allocation/cable 11 core

PIN	Signal HTL	Signal TTL	Core colour (cable outlet)	Explanation
1	N. C.	$\bar{B}$	black	Signal line
2	N. C.	Sense +	grey	Connected internally to $U_s$
3	Z	Z	lilac	Signal line
4	N. C.	$\bar{Z}$	yellow	Signal line
5	A	A	white	Signal line
6	N. C.	$\bar{A}$	brown	Signal line
7	N. C.	N. C.	orange	N. C.
8	B	B	pink	Signal line
9	Screen	Screen		Housing potential
10	GND	GND	blue	Ground connection
11	N. C.	Sense -	green	Connected internally to ground
12	$U_s$	$U_s$	red	Power supply <sup>1)</sup>

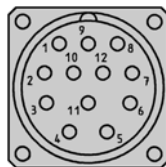

View of the connector M23 fitted to the encoder body

<sup>1)</sup> Potential free to housing  
N. C. =  
Not Connected

### Accessories

- Connection systems
- Mounting systems
- Collets





Technical Data to DIN 32878		DGS65	Flange type											
			blind											
<b>Hollow shaft diameter</b>	6, 8, 10, 11, 12 mm and 3/8"													
<b>Number of lines (Z) per revolution</b>	00100 to 10,000, see order info													
<b>Attention: number of lines &gt; 5000</b>	Only with TTL 4...6 V													
<b>Electrical Interface</b>	TTL/RS 422, 6-channel													
	HTL/push-pull, 3-channel (A, B, Z)													
<b>Mass <sup>1)</sup></b>	Approx. 0.4 kg													
<b>Moment of inertia of the rotor</b>	25 gcm <sup>2</sup>													
<b>Measuring step</b>	90°/number of lines													
<b>Reference signal</b>														
Number	1													
Position	90° electr. & logically interlocked with A+B													
<b>Error limits</b>														
100 ≤ Z < 1250	45/Z + 0.054°													
1250 < Z ≤ 10000	45/Z + 0.039°													
<b>Measuring step deviation</b>	45/Z °													
<b>Max. output frequency</b>														
TTL	300 kHz (600 at > 5000 lines)													
HTL	200 kHz													
<b>Max. operating speed</b>	6,000 min <sup>-1</sup>													
<b>Max. angular acceleration</b>	5 x 10 <sup>5</sup> rad/s <sup>2</sup>													
<b>Operating torque</b>	0.1 Ncm													
<b>Start up torque</b>	0.3 Ncm													
<b>Permissible shaft movement</b>														
static	radial/axial	± 0.5 mm/± 0.5 mm												
dynamic	radial/axial	± 0.1 mm/± 0.2 mm												
<b>Angular movement at right angles to the axis</b>														
static	34 x 10 <sup>-3</sup> mm													
dynamic	17 x 10 <sup>-3</sup> mm													
<b>Bearing lifetime</b>	3.6 x 10 <sup>10</sup> revolutions													
<b>Working temperature range</b>	- 20 ... + 85 °C													
<b>Storage temperature range</b>	- 30 ... + 85 °C													
<b>Permissible relative humidity <sup>2)</sup></b>	90 %													
<b>EMC <sup>3)</sup></b>														
<b>Resistance</b>														
to shocks <sup>4)</sup>	30/11 g/ms													
to vibration <sup>5)</sup>	20/10 ... 2000 g/Hz													
<b>Protection class acc. IEC 60529</b>														
Connector outlet <sup>6)</sup>	IP 65													
Cable outlet	IP 66													
<b>Operating voltage range</b>														
Load current TTL/RS 422, 4 ... 6 V	Max. 20 mA													
	TTL/RS 422, 10 ... 30 V	Max. 20 mA												
	HTL/push-pull, 10 ... 30 V	Max. 60 mA												
<b>Operating current range at no load</b>														
at 24 V	100 mA													
at 5 V	120 mA													

<sup>1)</sup> For an encoder with connector outlet

<sup>2)</sup> Condensation not permitted

<sup>3)</sup> To DIN EN 61000-6-2 and DIN EN 61000-6-3

<sup>4)</sup> To DIN EN 60068-2-27

<sup>5)</sup> To DIN EN 60068-2-6

<sup>6)</sup> With mating connector fitted

**Number of lines**  
100 to 10,000

Incremental Encoder

- Collets for shaft diameter 6, 8, 10, 11, 12 mm and 3/8"
- Connector or cable outlet
- Electrical Interfaces  
TTL and HTL

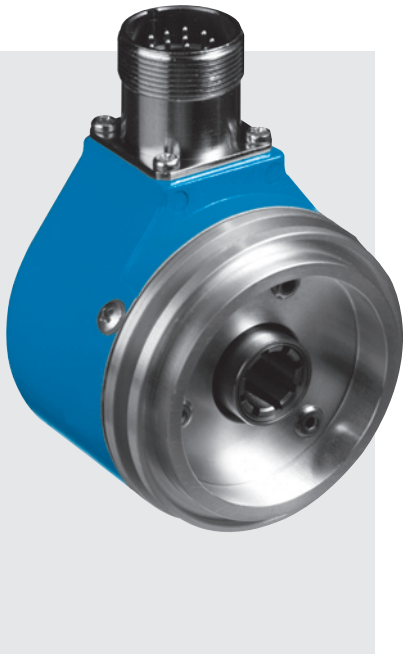

### Incremental pulse diagram

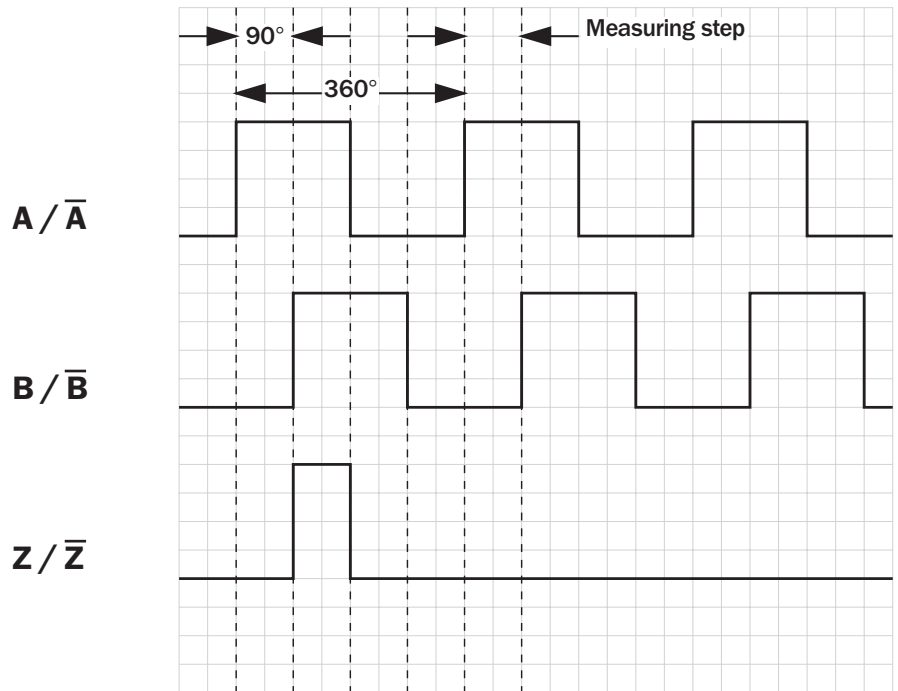

### Electrical interfaces

Supply voltage	4 ... 6 V	10 ... 30 V	10 ... 30 V
Interfaces/drivers	TTL (RS 422)	TTL (RS 422)	HTL (push-pull)

### Connection type

Cable radial	Connector radial
--------------	------------------

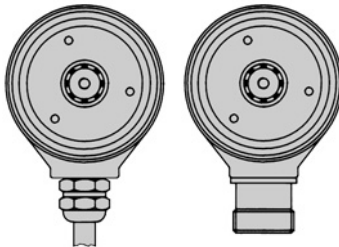

### Accessories

- Connection systems
- Mounting systems
- Collets





**Order information**

**Incremental Encoder DGS65, blind hollow shaft**

Point 1	Point 2	Point 3	Point 4	Point 5	Point 6	Point 7	Point 8	Point 9	Point 10	Point 11	Point 12	Point 13	Point 14
<b>D</b>	<b>G</b>	<b>S</b>	<b>6</b>	<b>5</b>	-								

<b>Electrical interface</b>	<b>Mechanical interface</b>	<b>Connection type</b>	<b>Number of lines</b>
4 ... 6 V, TTL (RS 422) = <b>A</b>	Blind hollow shaft <sup>1)</sup> = <b>A</b>	Connector M23, 12 pin, radial = <b>A</b>	Always 5 characters in clear text <b>1</b>
10 ... 30 V, TTL (RS 422) = <b>C</b>	<sup>1)</sup> Collets for 6, 8, 10, 11, 12 mm and 3/8" as accessories, separate order item (see below).	Cable 11 core, radial 1.5 m = <b>K</b>	
10 ... 30 V, HTL (push-pull) = <b>G</b>		Cable 11 core, radial 3 m = <b>L</b>	
		Cable 11 core, radial 5 m = <b>M</b>	

**1 Number of lines (Z) per revolution**

00100	00244	00336	00600	00785	01024	02000	04096
00125	00250	00360	00625	00800	01200	02048	05000
00150	00256	00400	00700	00900	01250	02500	07200 <sup>2)</sup>
00160	00300	00500	00720	00938	01375	03000	08192 <sup>2)</sup>
00180	00308	00512	00750	01000	01500	03600	10000 <sup>2)</sup>
00200	00314	00570	00768	01005	01800	04000	

<sup>2)</sup> Only possible with interface 4 ... 6 V, TTL (RS 422) = A

**Order example: Incremental Encoder DGS65**

**4 ... 6 V, TTL; blind hollow shaft; connector M23, 12 pin, radial; number of lines: 360**

Point 1	Point 2	Point 3	Point 4	Point 5	Point 6	Point 7	Point 8	Point 9	Point 10	Point 11	Point 12	Point 13	Point 14
<b>D</b>	<b>G</b>	<b>S</b>	<b>6</b>	<b>5</b>	-	<b>A</b>	<b>A</b>	<b>A</b>	<b>0</b>	<b>0</b>	<b>3</b>	<b>6</b>	<b>0</b>

**Please enter your individual encoder here**

Point 1	Point 2	Point 3	Point 4	Point 5	Point 6	Point 7	Point 8	Point 9	Point 10	Point 11	Point 12	Point 13	Point 14
<b>D</b>	<b>G</b>	<b>S</b>	<b>6</b>	<b>5</b>	-								

Point 1	Point 2	Point 3	Point 4	Point 5	Point 6	Point 7	Point 8	Point 9	Point 10	Point 11	Point 12	Point 13	Point 14
<b>D</b>	<b>G</b>	<b>S</b>	<b>6</b>	<b>5</b>	-								

Point 1	Point 2	Point 3	Point 4	Point 5	Point 6	Point 7	Point 8	Point 9	Point 10	Point 11	Point 12	Point 13	Point 14
<b>D</b>	<b>G</b>	<b>S</b>	<b>6</b>	<b>5</b>	-								

**Collets for DGS65 Encoder with blind hollow shaft**

Type	Part no.	Shaft diameter
SPZ-006-DD65-A	2029181	6 mm
SPZ-008-DD65-A	2029182	8 mm
SPZ-010-DD65-A	2029183	10 mm
SPZ-011-DD65-A	2019043	11 mm
SPZ-012-DD65-A	2029184	12 mm
SPZ-3E8-DD65-A	2039227	3/8 "



Technical Data to DIN 32878		DGS66	Flange type							
			blind	through						
<b>Hollow shaft diameter</b>	6, 8, 9, 10, 12, 14 and 15 mm, 1/2"									
	6, 8, 10, 12, 14 mm, 3/8" and 1/2"									
<b>Number of lines (Z) per revolution</b>	00100 to 10,000, see order info									
<b>Attention: number of lines &gt; 5000</b>	Only with TTL 4...6V									
<b>Electrical Interface</b>	TTL/RS 422, 6-channel									
	HTL/push-pull, 3-channel (A, B, Z)									
<b>Mass <sup>4)</sup></b>	Approx. 0.3 kg									
<b>Moment of inertia of the rotor</b>	45 gcm <sup>2</sup>									
<b>Measuring step</b>	90°/number of lines									
<b>Reference signal</b>										
Number	1									
Position	90° electr. & logically interlocked with A+B									
<b>Error limits</b>										
100 ≤ Z < 1250	45/Z + 0.054°									
1250 < Z ≤ 10000	45/Z + 0.039°									
<b>Measuring step deviation</b>	45/Z °									
<b>Max. output frequency</b>										
TTL	300 kHz (600 at > 5000 lines)									
HTL	200 kHz									
<b>Max. operating speed</b>	6,000 min <sup>-1</sup>									
<b>Max. angular acceleration</b>	5 x 10 <sup>5</sup> rad/s <sup>2</sup>									
<b>Operating torque</b>	0.2 Ncm									
<b>Start up torque</b>	0.4 Ncm									
<b>Permissible shaft movement</b>										
static	radial/axial	± 0.1 mm/± 2.0 mm								
dynamic	radial/axial	± 0.05 mm/± 0.2 mm								
<b>Angular movement at right angles to the axis</b>										
static		34 x 10 <sup>-3</sup> mm								
dynamic		17 x 10 <sup>-3</sup> mm								
<b>Bearing lifetime</b>		3.6 x 10 <sup>10</sup> revolutions								
<b>Working temperature range</b>		- 20 ... + 85 °C								
<b>Storage temperature range</b>		- 30 ... + 85 °C								
<b>Permissible relative humidity <sup>4)</sup></b>		90 %								
<b>EMC <sup>2)</sup></b>										
<b>Resistance</b>										
to shocks <sup>3)</sup>		30/11 g/ms								
to vibration <sup>4)</sup>		20/10 ... 2000 g/Hz								
<b>Protection class acc. IEC 60529</b>										
Cable outlet		IP 65								
<b>Operating voltage range</b>										
Load current	TTL/RS 422, 4 ... 6 V	Max. 20 mA								
	TTL/RS 422, 10 ... 30 V	Max. 20 mA								
	HTL/push-pull, 10 ... 30 V	Max. 60 mA								
<b>Operating current range at no load</b>										
at 24 V		100 mA								
at 5 V		120 mA								

<sup>4)</sup> Condensation not permitted<sup>3)</sup> To DIN EN 60068-2-27<sup>2)</sup> To DIN EN 61000-6-2  
and DIN EN 61000-6-3<sup>4)</sup> To DIN EN 60068-2-6

 **Number of lines**  
**100 to 10,000**

**Incremental Encoder**

- 100 to 10,000 number of lines per revolution
- Electrical Interfaces  
TTL and HTL

**Incremental pulse diagram**

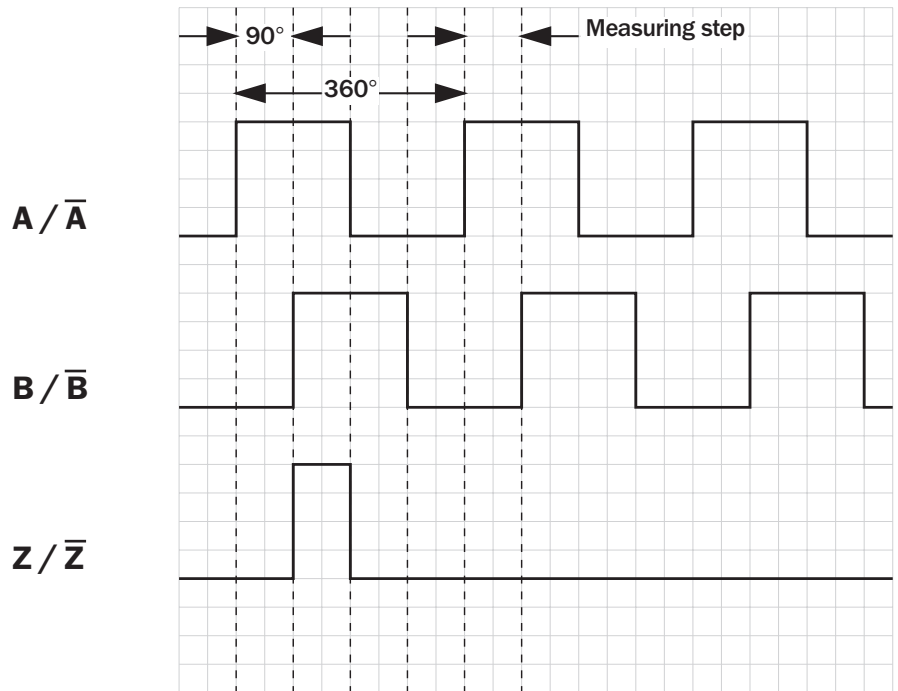

**Electrical interfaces**

Supply voltage	4 ... 6 V	10 ... 30 V	10 ... 30 V
Interfaces/drivers	TTL (RS 422)	TTL (RS 422)	HTL (push-pull)

**Connection type**

Cable radial

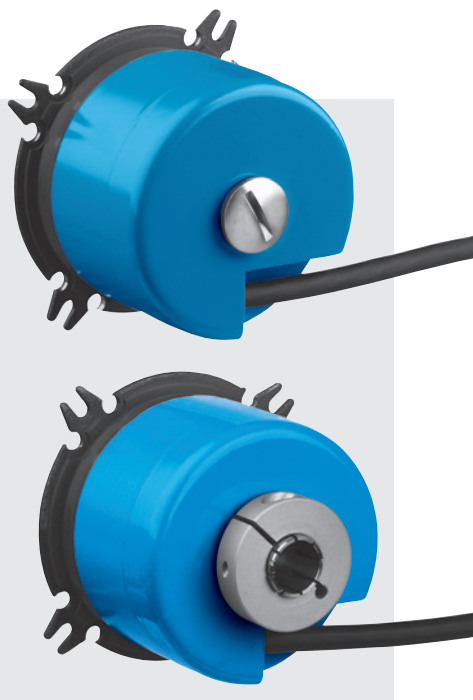
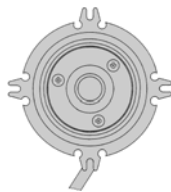

**Accessories**

Connection systems
Mounting systems
Collets

**Order information**

**Incremental Encoder DGS66, blind/through hollow shaft**

Point 1	Point 2	Point 3	Point 4	Point 5	Point 6	Point 7	Point 8	Point 9	Point 10	Point 11	Point 12	Point 13	Point 14
<b>D</b>	<b>G</b>	<b>S</b>	<b>6</b>	<b>6</b>	-								

<b>Electrical interface</b>	<b>Mechanical interface</b>	<b>Connection type</b>	<b>Number of lines</b>
4 ... 6 V, TTL (RS 422) = <b>A</b>	Blind hollow shaft <sup>1)</sup> = <b>A</b>	Cable 8 core, radial 1.5 m = <b>K</b>	Always 5 characters in clear text <b>1</b>
10 ... 30 V, TTL (RS 422) = <b>C</b>		Cable 8 core, radial 3 m = <b>L</b>	
10 ... 30 V, HTL (push-pull) = <b>G</b>	Through hollow shaft 6 mm = <b>M</b>	Cable 8 core, radial 5 m = <b>M</b>	
	Through hollow shaft 8 mm = <b>P</b>		
	Through hollow shaft 3/8" = <b>R</b>		
	Through hollow shaft 10 mm = <b>S</b>		
	Through hollow shaft 12 mm = <b>T</b>		
	Through hollow shaft 1/2" = <b>U</b>		
	Through hollow shaft 14 mm = <b>V</b>		

<sup>1)</sup> Collets for 6, 8, 10, 12, 14, 15 mm and 1/2" as accessories, separate order item (see below).

**1 Number of lines (Z) per revolution with electrical interface 4 ... 6 V, TTL (RS 422) = A**

00100	00360	00720	01250	02500	04000	05000	08192
00200	00500	01000	02000	03600	04096	07200	10000
00250	00512	01024	02048				

**1 Number of lines (Z) per revolution with the electrical interfaces 10 ... 30 V, TTL (RS 422) = C and 10 ... 30 V, HTL (push-pull) = G**

00100	00360	00515	01024	02000	02500	04096	
00250	00500	01000	01250	02048	03600	05000	

**Order example Incremental Encoder DGS66**

**4 ... 6 V, TTL; blind hollow shaft; cable 8 core 1.5 m, radial; number of lines: 360**

Point 1	Point 2	Point 3	Point 4	Point 5	Point 6	Point 7	Point 8	Point 9	Point 10	Point 11	Point 12	Point 13	Point 14
<b>D</b>	<b>G</b>	<b>S</b>	<b>6</b>	<b>6</b>	-	<b>A</b>	<b>A</b>	<b>K</b>	<b>0</b>	<b>0</b>	<b>3</b>	<b>6</b>	<b>0</b>

**Please enter your individual encoder here**

Point 1	Point 2	Point 3	Point 4	Point 5	Point 6	Point 7	Point 8	Point 9	Point 10	Point 11	Point 12	Point 13	Point 14
<b>D</b>	<b>G</b>	<b>S</b>	<b>6</b>	<b>6</b>	-								

Point 1	Point 2	Point 3	Point 4	Point 5	Point 6	Point 7	Point 8	Point 9	Point 10	Point 11	Point 12	Point 13	Point 14
<b>D</b>	<b>G</b>	<b>S</b>	<b>6</b>	<b>6</b>	-								

Point 1	Point 2	Point 3	Point 4	Point 5	Point 6	Point 7	Point 8	Point 9	Point 10	Point 11	Point 12	Point 13	Point 14
<b>D</b>	<b>G</b>	<b>S</b>	<b>6</b>	<b>6</b>	-								

**Collets for DGS66 Encoder with blind hollow shaft**

Type	Part no.	Shaft diameter
SPZ-006-DD66-A	2029185	6 mm
SPZ-008-DD66-A	2029186	8 mm
SPZ-009-DD66-A	2040980	9 mm
SPZ-010-DD66-A	2029187	10 mm
SPZ-012-DD66-A	2029188	12 mm
SPZ-1E2-DD66-A	2029189	1/2 "
SPZ-014-DD66-A	2029190	14 mm
SPZ-015-DD66-A	2029191	15 mm

Dimensional drawings and order information

Screw-in system M23, 12 pin

Cable onnector M23 female, 12 pin, straight, screened

Type	Part no.	Contacts
DOS-2312-G	6027538	12

Cable onnector M23 male, 12 pin, straight, screened

Type	Part no.	Contacts
STE-2312-G	6027537	12

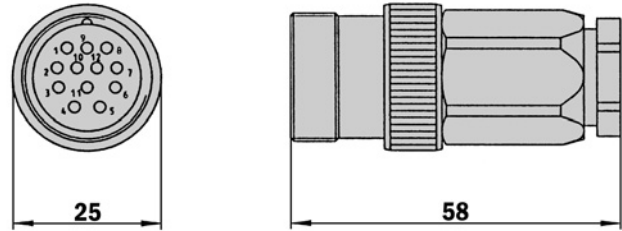
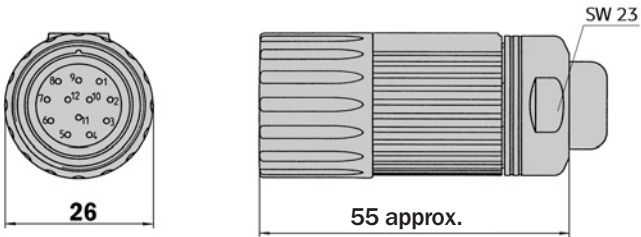

Connector M23 female, 12 pin, straight, cable 12 core, 4 x 2 x 0.25 + 2 x 0.5 + 2 x 0.14 mm<sup>2</sup> with screening, capable of being dragged, cable diameter 7.8 mm

Type	Part no.	Contacts	Cable length
DOL-2312-G1M5MA3	2029212	12	1.5 m
DOL-2312-G03MMA3	2029213	12	3.0 m
DOL-2312-G05MMA3	2029214	12	5.0 m
DOL-2312-G10MMA3	2029215	12	10.0 m
DOL-2312-G20MMA3	2029216	12	20.0 m
DOL-2312-G30MMA3	2029217	12	30.0 m

Cable 8 core, per meter, 4 x 2 x 0.15 mm<sup>2</sup> with screening, cable diameter 5.6 mm

Type	Part no.	Cores
LTG-2308-MWENC	6027529	8

Cable 11 core, per meter, 4 x 2 x 0.25 + 2 x 0.5 + 1 x 0.14 mm<sup>2</sup> with screening, cable diameter 7.5 mm

Type	Part no.	Cores
LTG-2411-MW	6027530	11

Cable 12 core, per meter, 4 x 2 x 0.25 + 2 x 0.5 + 2 x 0.14 mm<sup>2</sup> with screening, capable of being dragged, cable diameter 7.8 mm

Type	Part no.	Cores	Explanation
LTG-2512-MW	6027531	12	
LTG-2612-MW	6028516	12	Salt water and UV resistant

## Dimensional drawings and order information

## Couplings

**Bellows coupling, max. shaft offset radial  $\pm 0.3$  mm, axial 0.4 mm, angle  $\pm 4$  degrees, torsion spring stiffness 120 Nm/rad, bellows of stainless steel, hubs of aluminium**

Type	Part no.	Shaft diameter
KUP-0606-B	5312981	6 mm ... 6 mm
KUP-0610-B	5312982	6 mm ... 10 mm
KUP-1010-B	5312983	10 mm ... 10 mm
KUP-1012-B	5312984	10 mm ... 12 mm

Cheese-head screw  
M2,5x8 DIN912 A2

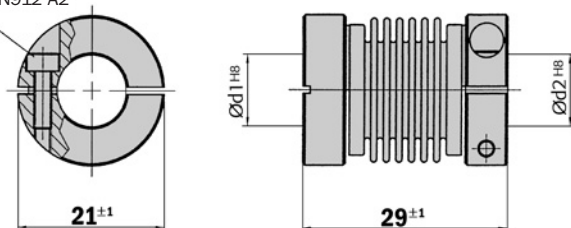

**Spring-disc coupling, max. shaft offset radial  $\pm 0.3$  mm, axial 0.4 mm, angle  $\pm 2.5$  degrees, torsion spring stiffness 50 Nm/rad, flange of stainless steel, spring-discs of glass-fibre-reinforced plastic**

Type	Part no.	Shaft diameter
KUP-0610-F	5312985	6 mm ... 10 mm
KUP-1010-F	5312986	10 mm ... 10 mm

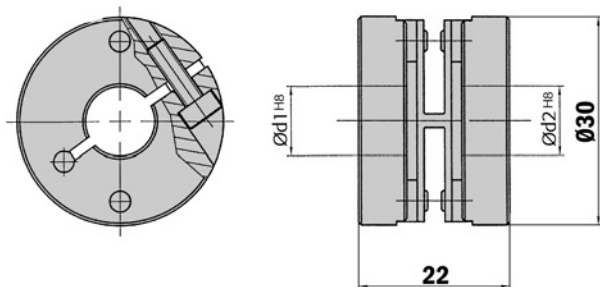

General tolerances according to DIN ISO 2768-mk





Dimensional drawings and order information

Mechanical Adaptors

Mounting bell incl. fixing set for encoder with servo flange

Type	Part no.	Flange spigot
BEF-MG-50	5312987	Diameter 50 mm

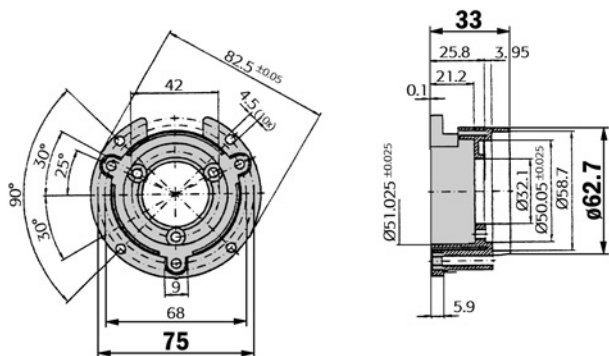

General tolerances according to DIN ISO 2768-mk

Mounting angle incl. fixing set for encoder with face mount flange

Type	Part no.	Flange spigot
BEF-WF-36	2029164	Diameter 36 mm

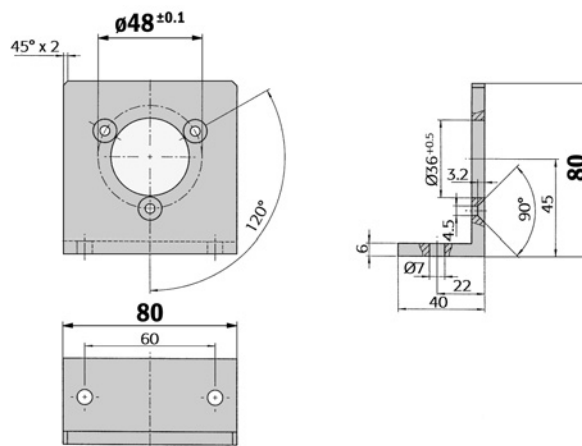

General tolerances according to DIN ISO 2768-mk

Servo clamps half ring, Set (comprises 2 pieces) for servo flanges with spigot diameter 50 mm

Type	Part no.
BEF-WG-SF050	2029165

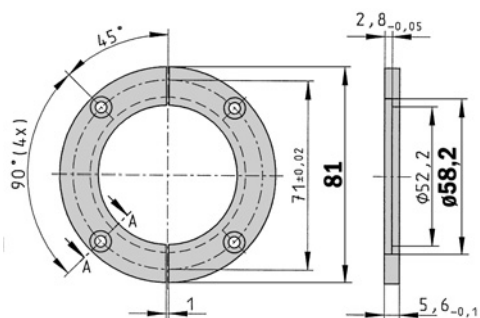

General tolerances according to DIN ISO 2768-mk

Servo clamps small, Set (comprises 3 pieces) for servo flanges

Type	Part no.
BEF-WK-SF	2029166

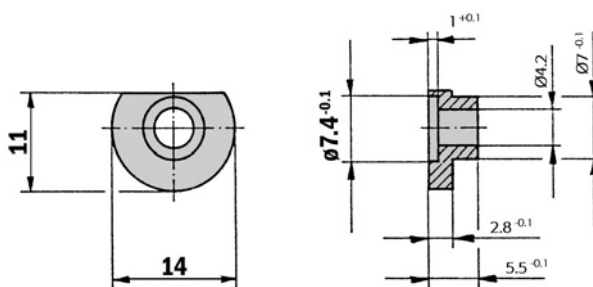

General tolerances according to DIN ISO 2768-mk

## Dimensional drawings and order information

### Mechanical Adaptors

#### Measuring wheel for encoder shafts with diameter 10 mm, type material plastic (Hytrel), wheel material plastic with aluminium hub

Type	Part no.	Circumference	Surface
BEF-MR-010020	5312988	0.2 m	smooth
BEF-MR-010020G	5318678	0.2 m	knurled

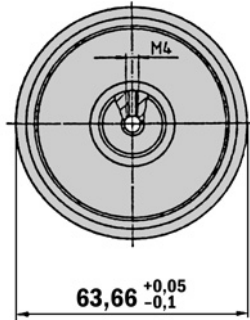

General tolerances according to DIN ISO 2768-mk

#### Measuring wheel for encoder shafts with diameter 10 mm, type material plastic (Hytrel), wheel material plastic with aluminium hub

Type	Part no.	Circumference	Surface
BEF-MR-010050	5312989	0.5 m	smooth

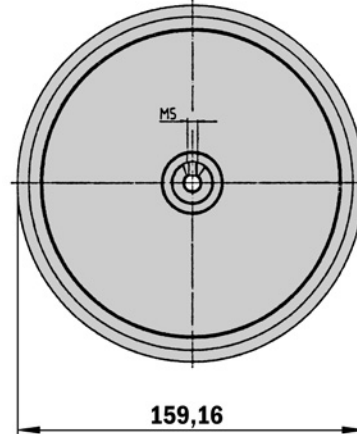

General tolerances according to DIN ISO 2768-mk

### Collets

#### Collets for DGS65 blind hollow shaft encoder

Type	Part no.	Shaft diameter
SPZ-006-DD65-A	2029181	6 mm
SPZ-008-DD65-A	2029182	8 mm
SPZ-010-DD65-A	2029183	10 mm
SPZ-011-DD65-A	2019043	11 mm
SPZ-012-DD65-A	2029184	12 mm
SPZ-3E8-DD65-A	2039227	$\frac{3}{8}$ "

#### Collets for DGS66 Encoder with blind hollow shaft

Type	Part no.	Shaft diameter
SPZ-006-DD66-A	2029185	6 mm
SPZ-008-DD66-A	2029186	8 mm
SPZ-009-DD66-A	2040980	9 mm
SPZ-010-DD66-A	2029187	10 mm
SPZ-012-DD66-A	2029188	12 mm
SPZ-1E2-DD66-A	2029189	$\frac{1}{2}$ "
SPZ-014-DD66-A	2029190	14 mm
SPZ-015-DD66-A	2029191	15 mm



**Australia**

Phone +61 3 9497 4100  
1800 33 48 02 – tollfree  
E-Mail sales@sick.com.au

**Belgium/Luxembourg**

Phone +32 (0)2 466 55 66  
E-Mail info@sick.be

**Brasil**

Phone +55 11 5091-4900  
E-Mail sac@sick.com.br

**Ceská Republika**

Phone +420 2 57 91 18 50  
E-Mail sick@sick.cz

**China**

Phone +852-2763 6966  
E-Mail ghk@sick.com.hk

**Danmark**

Phone +45 45 82 64 00  
E-Mail sick@sick.dk

**Deutschland**

Phone +49 (0)2 11 53 01-250  
E-Mail info@sick.de

**España**

Phone +34 93 480 31 00  
E-Mail info@sick.es

**France**

Phone +33 1 64 62 35 00  
E-Mail info@sick.fr

**Great Britain**

Phone +44 (0)1727 831121  
E-Mail info@sick.co.uk

**India**

Phone +91-22-2822 7084  
E-Mail info@sick-india.com

**Italia**

Phone +39 011 79 79 65  
E-Mail info@sick.it

**Japan**

Phone +81 (0)3 3358 1341  
E-Mail support@sick.jp

**Nederlands**

Phone +31 (0)30 229 25 44  
E-Mail info@sick.nl

**Norge**

Phone +47 67 81 50 00  
E-Mail austefjord@sick.no

**Österreich**

Phone +43 (0)22 36 62 28 8-0  
E-Mail office@sick.at

**Polska**

Phone +48 22 837 40 50  
E-Mail info@sick.pl

**Republic of Korea**

Phone +82-2 786 6321/4  
E-Mail kang@sickkorea.net

**Republika Slovenija**

Phone +386 (0)1-47 69 990  
E-Mail office@sick.si

**Russia**

Phone +7 495 775 05 34  
E-Mail denis.kesaev@  
sickautomation.ru

**Schweiz**

Phone +41 41 619 29 39  
E-Mail contact@sick.ch

**Singapore**

Phone +65 6744 3732  
E-Mail admin@sicksgp.com.sg

**Suomi**

Phone +358-9-25 15 800  
E-Mail sick@sick.fi

**Sverige**

Phone +46 8 680 64 50  
E-Mail info@sick.se

**Taiwan**

Phone +886 2 2365-6292  
E-Mail sickgrc@ms6.hinet.net

**Türkiye**

Phone +90 216 587 74 00  
E-Mail info@sick.com.tr

**USA**

Phone +1 937-454-1956  
E-Mail sales@stegmann.com

More representatives and agencies  
in all major industrial nations at  
[www.sick.com](http://www.sick.com)

