

Documentation | EN

EL9xxx

EtherCAT System Terminals



EtherCAT®

Table of contents

1	Foreword	5
1.1	Notes on the documentation	5
1.2	Safety instructions	6
1.3	Documentation issue status	7
1.4	Intended use	8
1.5	Version identification of EtherCAT devices	8
1.5.1	General notes on marking.....	8
1.5.2	Version identification of EL terminals.....	9
1.5.3	Beckhoff Identification Code (BIC).....	10
1.5.4	Electronic access to the BIC (eBIC).....	12
1.6	Interference-free Bus Terminals.....	14
2	Product description	20
2.1	Overview EtherCAT System and Function terminals	20
2.2	EL9011, EL9012, EL9080	21
2.2.1	EL9011, EL9012, EL9080 - Introduction and Technical Data	21
2.3	EL9070.....	23
2.3.1	EL9070 - Introduction and Technical Data.....	23
2.4	EL9100, EL9110, EL9190	25
2.4.1	EL9100, EL9110, EL9190 - Introduction and Technical Data	25
2.5	EL9150, EL9160	29
2.5.1	EL9150, EL9160 - Introduction and Technical Data	29
2.6	EL9180.....	32
2.6.1	EL9180 - Introduction and Technical Data.....	32
2.7	EL9181, EL9182, EL9183	35
2.7.1	EL9181, EL9182, EL9183 - Introduction and Technical Data	35
2.8	EL9184, EL9185, EL9185-0010, EL9186, EL9187, EL9188, EL9189	39
2.8.1	EL9184, EL9185, EL9185-0010, EL9186, EL9187, EL9188, EL9189 - Introduction and Technical Data	39
2.9	EL9195.....	49
2.9.1	EL9195 - Introduction and Technical Data.....	49
2.10	EL9200, EL9210, EL9290	52
2.10.1	EL9200, EL9210, EL9290 - Introduction and Technical Data	52
2.11	EL9250, EL9260	56
2.11.1	EL9250, EL9260 - Introduction and Technical Data	56
2.12	EL9400, EL9410	59
2.12.1	EL9400, EL9410 - Introduction and Technical Data	59
2.13	EL9540, EL9540-0010, EL9550, EL9550-0010, EL9550-0012	62
2.13.1	EL9540, EL9540-0010, EL9550, EL9550-0010, EL9550-0012 - Introduction and Technical Data.....	62
2.13.2	EL9540, EL9550 - application example	70
2.13.3	EL9540-0010, EL9550 - application example	71
2.14	EL9570.....	72
2.14.1	EL9570 - Introduction and Technical Data.....	72
2.14.2	Application example	75

3	Basics communication	77
3.1	EtherCAT basics	77
3.2	EtherCAT cabling – wire-bound	77
3.3	EtherCAT State Machine	78
3.4	CoE Interface	79
4	Mounting and wiring	85
4.1	Instructions for ESD protection	85
4.2	Explosion protection	86
4.2.1	ATEX - Special conditions (standard temperature range)	86
4.2.2	ATEX - Special conditions (extended temperature range)	87
4.2.3	IECEX - Special conditions	88
4.2.4	Continuative documentation for ATEX and IECEX	89
4.2.5	cFMus - Special conditions	90
4.2.6	Continuative documentation for cFMus	91
4.3	UL notice	92
4.4	Installation on mounting rails	93
4.5	Installation positions	96
4.6	Installation instructions for enhanced mechanical load capacity	98
4.7	Positioning of passive Terminals	99
4.8	Note - Power supply	100
4.9	Connection	101
4.9.1	Connection system	101
4.9.2	Wiring	103
4.9.3	Shielding	104
4.10	Disposal	105
5	TwinCAT System Manager	106
5.1	Configuration with TwinCAT System Manager - passive terminals	106
6	Appendix	107
6.1	EtherCAT AL Status Codes	107
6.2	Firmware compatibility - passive terminals	108
6.3	Support and Service	109

1 Foreword

1.1 Notes on the documentation

Intended audience

This description is only intended for the use of trained specialists in control and automation engineering who are familiar with the applicable national standards.

It is essential that the documentation and the following notes and explanations are followed when installing and commissioning these components.

The qualified personnel is obliged to always use the currently valid documentation.

The responsible staff must ensure that the application or use of the products described satisfy all the requirements for safety, including all the relevant laws, regulations, guidelines and standards.

Disclaimer

The documentation has been prepared with care. The products described are, however, constantly under development.

We reserve the right to revise and change the documentation at any time and without prior announcement.

No claims for the modification of products that have already been supplied may be made on the basis of the data, diagrams and descriptions in this documentation.

Trademarks

Beckhoff®, TwinCAT®, TwinCAT/BSD®, TC/BSD®, EtherCAT®, EtherCAT G®, EtherCAT G10®, EtherCAT P®, Safety over EtherCAT®, TwinSAFE®, XFC®, XTS® and XPlanar® are registered trademarks of and licensed by Beckhoff Automation GmbH. Other designations used in this publication may be trademarks whose use by third parties for their own purposes could violate the rights of the owners.

Patent Pending

The EtherCAT Technology is covered, including but not limited to the following patent applications and patents: EP1590927, EP1789857, EP1456722, EP2137893, DE102015105702 with corresponding applications or registrations in various other countries.



EtherCAT® is registered trademark and patented technology, licensed by Beckhoff Automation GmbH, Germany.

Copyright

© Beckhoff Automation GmbH & Co. KG, Germany.

The reproduction, distribution and utilization of this document as well as the communication of its contents to others without express authorization are prohibited.

Offenders will be held liable for the payment of damages. All rights reserved in the event of the grant of a patent, utility model or design.

1.2 Safety instructions

Safety regulations

Please note the following safety instructions and explanations!
Product-specific safety instructions can be found on following pages or in the areas mounting, wiring, commissioning etc.

Exclusion of liability

All the components are supplied in particular hardware and software configurations appropriate for the application. Modifications to hardware or software configurations other than those described in the documentation are not permitted, and nullify the liability of Beckhoff Automation GmbH & Co. KG.

Personnel qualification

This description is only intended for trained specialists in control, automation and drive engineering who are familiar with the applicable national standards.

Signal words

The signal words used in the documentation are classified below. In order to prevent injury and damage to persons and property, read and follow the safety and warning notices.

Personal injury warnings

⚠ DANGER

Hazard with high risk of death or serious injury.

⚠ WARNING

Hazard with medium risk of death or serious injury.

⚠ CAUTION

There is a low-risk hazard that could result in medium or minor injury.

Warning of damage to property or environment

NOTICE

The environment, equipment, or data may be damaged.

Information on handling the product



This information includes, for example:
recommendations for action, assistance or further information on the product.

1.3 Documentation issue status

Version	Comment
4.8.1	<ul style="list-style-type: none"> • Update chapter "UL notes" • Update chapter "Technical data" • Update structure
4.8	<ul style="list-style-type: none"> • Product images for EL9150, EL9160, EL9250 and EL9260 updated • Update technical data • Update structure
4.7	<ul style="list-style-type: none"> • Update chapter "Technical data" • Update chapter "LEDs and connection" • UL note added • Update structure
4.6	<ul style="list-style-type: none"> • Update chapter "LEDs and connection" • Update structure
4.5	<ul style="list-style-type: none"> • Update chapter "Interference-free Bus Terminals" • Update structure
4.4	<ul style="list-style-type: none"> • EL9540 and EL9550, application example added • Update structure
4.4	<ul style="list-style-type: none"> • EL9540 and EL9550, application example added • Update structure
4.3	<ul style="list-style-type: none"> • Update chapter "Technical data" • Update structure
4.2	<ul style="list-style-type: none"> • Update chapter "LEDs and connection" • Udate structure
4.1	<ul style="list-style-type: none"> • EL9450-0010, EL9550-0010 added • Update chapter "Technical data" • Update structure
4.0	<ul style="list-style-type: none"> • Update chapter "Technical data" • Update structure
0.1 ... 3.9	<ul style="list-style-type: none"> • *archieved*

1.4 Intended use

⚠ WARNING

Intended use

If the equipment is used in a manner not specified by the manufacturer, the protection provided by the equipment may be impaired.

1.5 Version identification of EtherCAT devices

1.5.1 General notes on marking

Designation

A Beckhoff EtherCAT device has a 14-digit designation, made up of

- family key
- type
- version
- revision

Example	Family	Type	Version	Revision
EL3314-0000-0016	EL terminal 12 mm, non-pluggable connection level	3314 4-channel thermocouple terminal	0000 basic type	0016
ES3602-0010-0017	ES terminal 12 mm, pluggable connection level	3602 2-channel voltage measurement	0010 high-precision version	0017
CU2008-0000-0000	CU device	2008 8-port fast ethernet switch	0000 basic type	0000

Notes

- The elements mentioned above result in the **technical designation**. EL3314-0000-0016 is used in the example below.
- EL3314-0000 is the order identifier, in the case of “-0000” usually abbreviated to EL3314. “-0016” is the EtherCAT revision.
- The **order identifier** is made up of
 - family key (EL, EP, CU, ES, KL, CX, etc.)
 - type (3314)
 - version (-0000)
- The **revision** -0016 shows the technical progress, such as the extension of features with regard to the EtherCAT communication, and is managed by Beckhoff.
In principle, a device with a higher revision can replace a device with a lower revision, unless specified otherwise, e.g. in the documentation.
Associated and synonymous with each revision there is usually a description (ESI, EtherCAT Slave Information) in the form of an XML file, which is available for download from the Beckhoff web site.
From 2014/01 the revision is shown on the outside of the IP20 terminals, see Fig. “EL5021 EL terminal, standard IP20 IO device with batch number and revision ID (since 2014/01)”.
- The type, version and revision are read as decimal numbers, even if they are technically saved in hexadecimal.

1.5.2 Version identification of EL terminals

The serial number/ data code for Beckhoff IO devices is usually the 8-digit number printed on the device or on a sticker. The serial number indicates the configuration in delivery state and therefore refers to a whole production batch, without distinguishing the individual modules of a batch.

Structure of the serial number: **KK YY FF HH**

KK - week of production (CW, calendar week)

YY - year of production

FF - firmware version

HH - hardware version

Example with serial number 12 06 3A 02:

12 - production week 12

06 - production year 2006

3A - firmware version 3A

02 - hardware version 02



Fig. 1: EL2872 with revision 0022 and serial number 01200815

1.5.3 Beckhoff Identification Code (BIC)

The Beckhoff Identification Code (BIC) is increasingly being applied to Beckhoff products to uniquely identify the product. The BIC is represented as a Data Matrix Code (DMC, code scheme ECC200), the content is based on the ANSI standard MH10.8.2-2016.

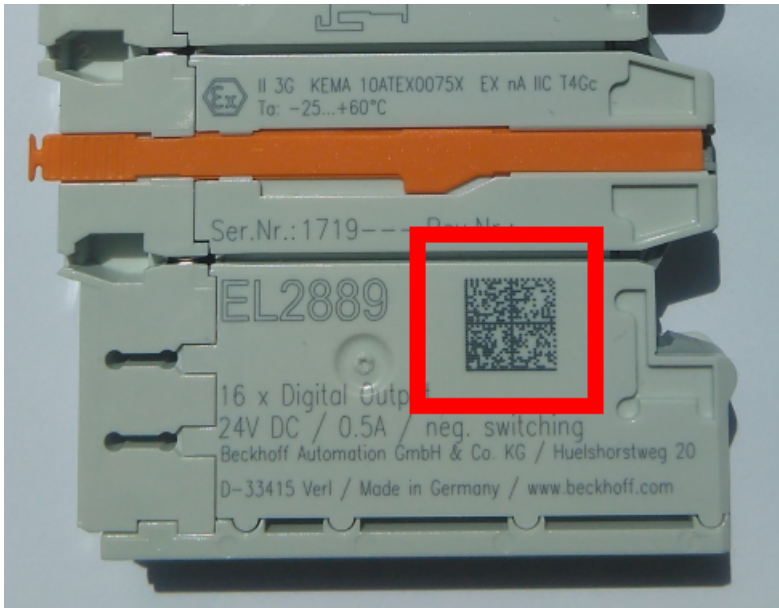

Fig. 2: BIC as data matrix code (DMC, code scheme ECC200)

The BIC will be introduced step by step across all product groups.

Depending on the product, it can be found in the following places:

- on the packaging unit
- directly on the product (if space suffices)
- on the packaging unit and the product

The BIC is machine-readable and contains information that can also be used by the customer for handling and product management.

Each piece of information can be uniquely identified using the so-called data identifier (ANSI MH10.8.2-2016). The data identifier is followed by a character string. Both together have a maximum length according to the table below. If the information is shorter, spaces are added to it.

Following information is possible, positions 1 to 4 are always present, the other according to need of production:

Position	Type of information	Explanation	Data identifier	Number of digits incl. data identifier	Example
1	Beckhoff order number	Beckhoff order number	1P	8	1P072222
2	Beckhoff Traceability Number (BTN)	Unique serial number, see note below	SBTN	12	SBTNk4p562d7
3	Article description	Beckhoff article description, e.g. EL1008	1K	32	1KEL1809
4	Quantity	Quantity in packaging unit, e.g. 1, 10, etc.	Q	6	Q1
5	Batch number	Optional: Year and week of production	2P	14	2P401503180016
6	ID/serial number	Optional: Present-day serial number system, e.g. with safety products	51S	12	51S678294
7	Variant number	Optional: Product variant number on the basis of standard products	30P	32	30PF971, 2*K183
...					

Further types of information and data identifiers are used by Beckhoff and serve internal processes.

Structure of the BIC

Example of composite information from positions 1 to 4 and with the above given example value on position 6. The data identifiers are highlighted in bold font:

1P072222**S**BTNk4p562d7**1**KEL1809 **Q1** **51S**678294

Accordingly as DMC:



Fig. 3: Example DMC **1**P072222**S**BTNk4p562d7**1**KEL1809 **Q1** **51S**678294

BTN

An important component of the BIC is the Beckhoff Traceability Number (BTN, position 2). The BTN is a unique serial number consisting of eight characters that will replace all other serial number systems at Beckhoff in the long term (e.g. batch designations on IO components, previous serial number range for safety products, etc.). The BTN will also be introduced step by step, so it may happen that the BTN is not yet coded in the BIC.

NOTICE

This information has been carefully prepared. However, the procedure described is constantly being further developed. We reserve the right to revise and change procedures and documentation at any time and without prior notice. No claims for changes can be made from the information, illustrations and descriptions in this information.

1.5.4 Electronic access to the BIC (eBIC)

Electronic BIC (eBIC)

The Beckhoff Identification Code (BIC) is applied to the outside of Beckhoff products in a visible place. If possible, it should also be electronically readable.

Decisive for the electronic readout is the interface via which the product can be electronically addressed.

K-bus devices (IP20, IP67)

Currently, no electronic storage and readout is planned for these devices.

EtherCAT devices (IP20, IP67)

All Beckhoff EtherCAT devices have a so-called ESI-EEPROM, which contains the EtherCAT identity with the revision number. Stored in it is the EtherCAT slave information, also colloquially known as ESI/XML configuration file for the EtherCAT master. See the corresponding chapter in the EtherCAT system manual ([Link](#)) for the relationships.

The eBIC is also stored in the ESI-EEPROM. The eBIC was introduced into the Beckhoff I/O production (terminals, box modules) from 2020; widespread implementation is expected in 2021.

The user can electronically access the eBIC (if existent) as follows:

- With all EtherCAT devices, the EtherCAT master (TwinCAT) can read the eBIC from the ESI-EEPROM
 - From TwinCAT 3.1 build 4024.11, the eBIC can be displayed in the online view.
 - To do this, check the checkbox "Show Beckhoff Identification Code (BIC)" under EtherCAT → Advanced Settings → Diagnostics:

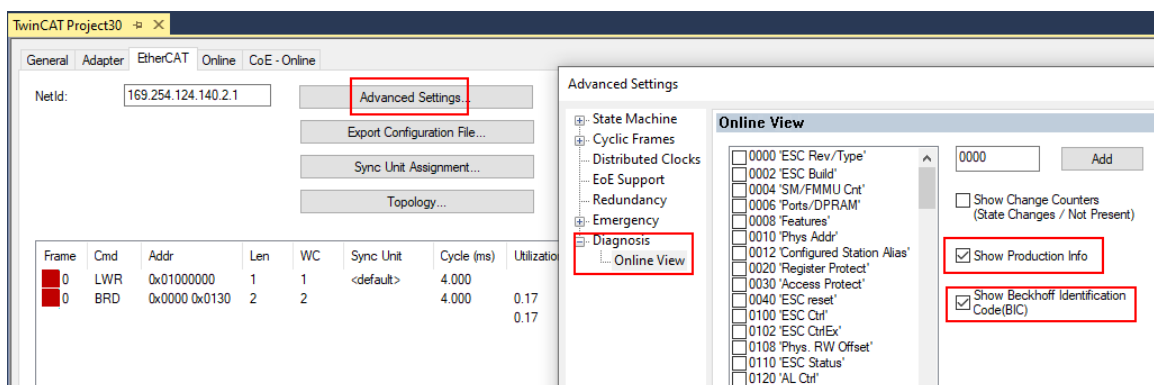

- The BTN and its contents are then displayed:

No	Addr	Name	State	CRC	Fw	Hw	Production Data	ItemNo	BTN	Description	Quantity	BatchNo	SerialNo
1	1001	Term 1 (EK1100)	OP	0.0	0	0	---						
2	1002	Term 2 (EL1018)	OP	0.0	0	0	2020 KW36 Fr	072222	k4p562d7	EL1809	1		678294
3	1003	Term 3 (EL3204)	OP	0.0	7	6	2012 KW24 Sa						
4	1004	Term 4 (EL2004)	OP	0.0	0	0	---	072223	k4p562d7	EL2004	1		678295
5	1005	Term 5 (EL1008)	OP	0.0	0	0	---						
6	1006	Term 6 (EL2008)	OP	0.0	0	12	2014 KW14 Mo						
7	1007	Term 7 (EK1110)	OP	0	1	8	2012 KW25 Mo						

- Note: as can be seen in the illustration, the production data HW version, FW version and production date, which have been programmed since 2012, can also be displayed with "Show Production Info".
- Access from the PLC: From TwinCAT 3.1. build 4024.24 the functions *FB_EcReadBIC* and *FB_EcReadBTN* are available in the Tc2_EtherCAT Library from v3.3.19.0 for reading into the PLC..
- In the case of EtherCAT devices with CoE directory, the object 0x10E2:01 can additionally be used to display the device's own eBIC; the PLC can also simply access the information here:

- The device must be in PREOP/SAFEOP/OP for access:

Index	Name	Flags	Value
1000	Device type	RO	0x015E1389 (22942601)
1008	Device name	RO	ELM3704-0000
1009	Hardware version	RO	00
100A	Software version	RO	01
100B	Bootloader version	RO	J0.1.27.0
1011:0	Restore default parameters	RO	> 1 <
1018:0	Identity	RO	> 4 <
10E2:0	Manufacturer-specific Identification C...	RO	> 1 <
10E2:01	SubIndex 001	RO	1P158442SBTN0008jckp1KELM3704 Q1 2P482001000016
10F0:0	Backup parameter handling	RO	> 1 <
10F3:0	Diagnosis History	RO	> 21 <
10F8	Actual Time Stamp	RO	0x170fb277e

- The object 0x10E2 will be introduced into stock products in the course of a necessary firmware revision.
- From TwinCAT 3.1. build 4024.24 the functions *FB_EcCoEReadBIC* and *FB_EcCoEReadBTN* are available in the *Tc2_EtherCAT Library* from v3.3.19.0 for reading into the PLC.
- For processing the BIC/BTN data in the PLC, the following auxiliary functions are available in *Tc2_Uilities* from TwinCAT 3.1 build 4024.24 onwards
 - *F_SplitBIC*: The function splits the Beckhoff Identification Code (BIC) *sBICValue* into its components based on known identifiers and returns the recognized partial strings in a structure *ST_SplitBIC* as return value.
 - *BIC_TO_BTN*: The function extracts the BTN from the BIC and returns it as a value.
- Note: in the case of electronic further processing, the BTN is to be handled as a string(8); the identifier "SBTN" is not part of the BTN.
- Technical background

The new BIC information is additionally written as a category in the ESI-EEPROM during the device production. The structure of the ESI content is largely dictated by the ETG specifications, therefore the additional vendor-specific content is stored with the help of a category according to ETG.2010. ID 03 indicates to all EtherCAT masters that they must not overwrite these data in case of an update or restore the data after an ESI update.

The structure follows the content of the BIC, see there. This results in a memory requirement of approx. 50..200 bytes in the EEPROM.
- Special cases
 - If multiple, hierarchically arranged ESCs are installed in a device, only the top-level ESC carries the eBIC Information.
 - If multiple, non-hierarchically arranged ESCs are installed in a device, all ESCs carry the eBIC Information.
 - If the device consists of several sub-devices with their own identity, but only the top-level device is accessible via EtherCAT, the eBIC of the top-level device is located in the CoE object directory 0x10E2:01 and the eBICs of the sub-devices follow in 0x10E2:nn.

PROFIBUS, PROFINET, DeviceNet devices etc.

Currently, no electronic storage and readout is planned for these devices.

1.6 Interference-free Bus Terminals

i Use of interference-free Bus or EtherCAT Terminals in safety applications

If a Bus or EtherCAT Terminal is described as interference-free, this means that the consecutive terminal behaves passively in a safety application (e.g. in the case of the all-pole switch-off of a potential group).

In this case the terminals do not represent an active part of the safety controller and do not affect the Safety Integrity Level (SIL) or Performance Level (PL) attained in the safety application.

For details, please refer chapter "All-pole disconnection of a potential group with downstream interference-free standard terminals (Category 4, PL e)" and following in the [TwinSAFE application manual](#).

NOTICE

Pay attention to the hardware version

Please pay attention to the information about the hardware version and non-reactivity of the respective Bus Terminal in the chapters "Technical Data" or "Firmware Compatibility"!

Only terminals with the appropriate hardware version may be used without the attained SIL/PL being affected!

The Bus or EtherCAT Terminals regarded as interference-free at the time of preparing this document are listed in the following tables together with their respective hardware versions.

Terminal name Bus Terminal	from hardware version
KL2408	05
KL2809	02
KL2134	09
KL2424	05
KL9110	07

Terminal name EL/ELX terminal	from hardware version
EL2004	15
EL2008	07
EL2014	00
EL2022	09
EL2024	06
EL2034	06
EL2044	01
EL2068	00
EL2212	00
EL2809	01
EL2819	00
EL2828	00
EL2869	00
EL2872	01
EL2878-0005	00
EL9110	13
EL9184	00
EL9185	00
EL9186	00
EL9187	00
EL9410	16
ELX1052	00
ELX1054	00
ELX1058	00
ELX2002	00
ELX2008	00
ELX3152	00
ELX3181	00
ELX3202	00
ELX3204	00
ELX3252	00
ELX3312	00
ELX3314	00
ELX3351	00
ELX4181	00
ELX5151	00
ELX9560	03

External wiring

The following requirements are to be ensured *by the system manufacturer* and must be incorporated into the user documentation.

- **Protection class IP54**
The terminals must be installed in IP54 control cabinets to ensure the necessary protection class IP54.
- **Power supply unit**
The standard terminals must be supplied with 24 V by an SELV/PELV power supply unit with an output voltage limit U_{\max} of 60 V in the event of a fault.
- **Prevention of feedback**
Feedback can be prevented through different measures. These are described below. In addition to mandatory requirements there are also optional requirements, of which only one needs to be selected.
 - **No switching of loads with a separate power supply**
Loads that have their own power supply must not be switched by standard terminals, since in this case feedback via the load cannot be ruled out.

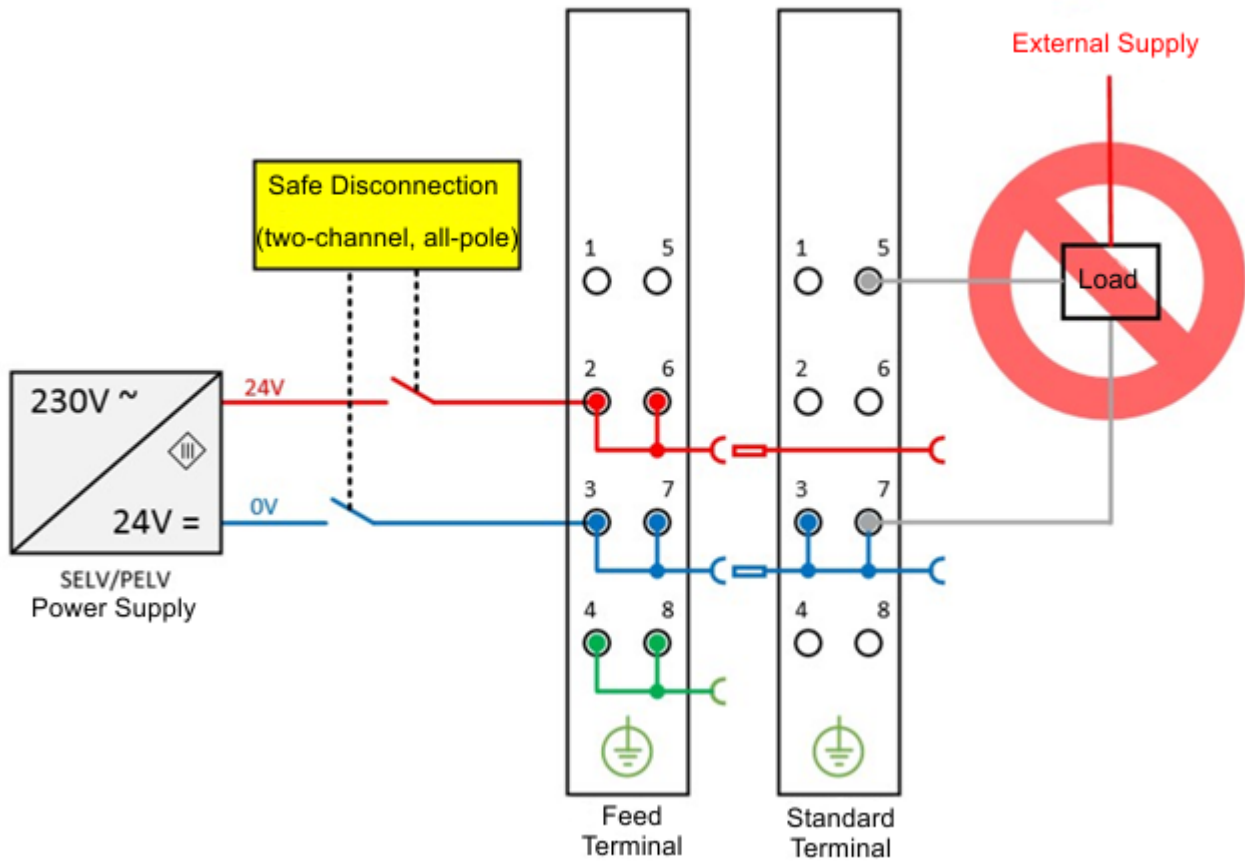

Fig. 4: Negative example – active load

- The control of an STO input of a frequency converter could serve here as a **negative example**. **Exceptions** to the general requirement are allowed only if the manufacturer of the connected load guarantees that feedback to the control input cannot occur. This can be achieved, for example, through adherence to load-specific standards.
- **Option 1: Ground feedback and all-pole disconnection**
The ground connection of the connected load must be fed back to the safely switched ground.

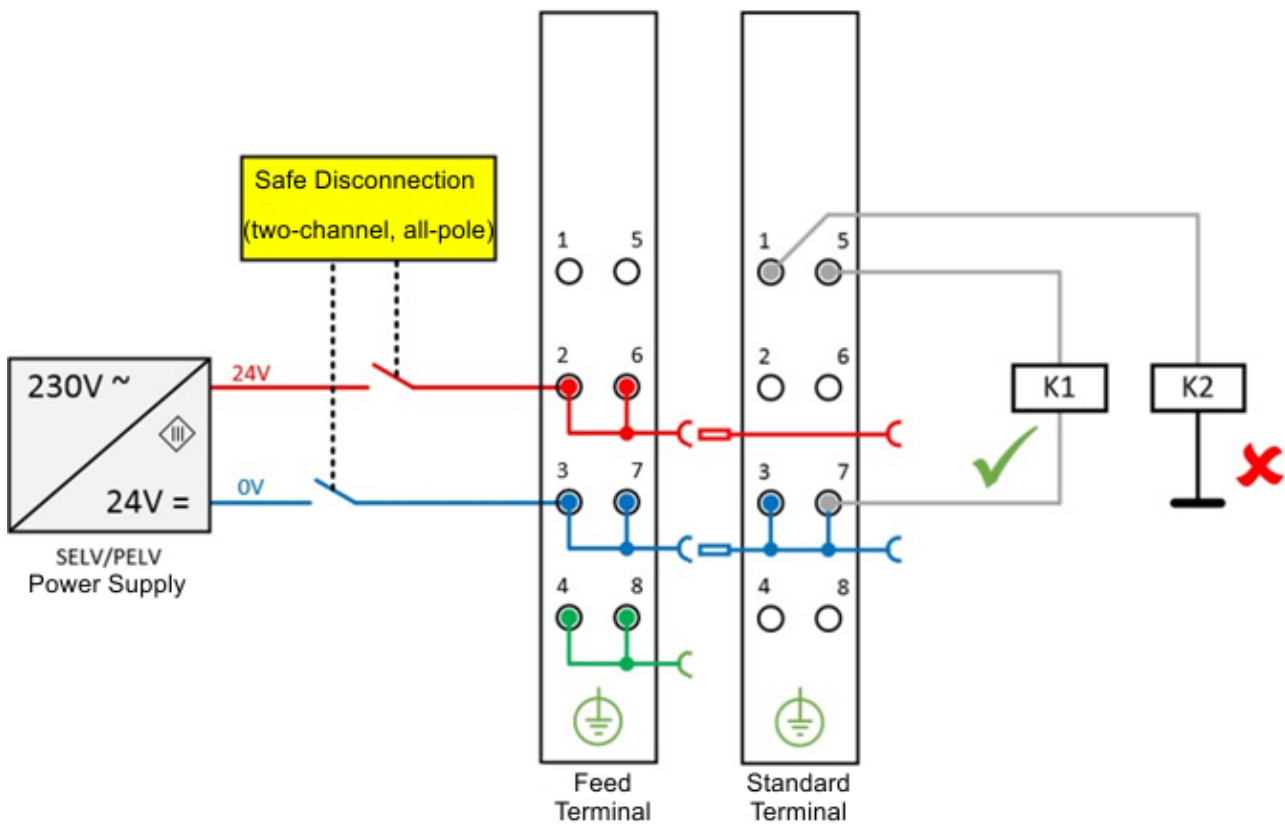

Fig. 5: Ground connection of the load: correct (K1) and incorrect (K2)

- If either
 - a) the ground of the load is not fed back to the terminal or
 - b) the ground is not safely switched but connected permanently

then fault exclusions are necessary with regard to a short-circuit with external potential in order to be able to achieve Cat. 4 PLe according to EN ISO 13849-1:2007 or SIL3 according to IEC 61508:2010 (refer here to the overview in the chapter "Effect of options on the safety level").

◦ **Option 2: Cable short-circuit fault exclusion**

If solution option 1 is not feasible, the ground feedback and all-pole disconnection can be dispensed with if the danger of feedback due to a cable short-circuit can be excluded by other measures. These measures, which can be implemented alternatively, are described in the following sections.

Summary of safety classifications

Feedback avoidance measures	DIN EN ISO 13849-1	IEC 61508	EN 62061
Fault exclusion	max.	max. SIL3	max. SIL2 *
Cable short-circuit	Cat. 4		
Ground feedback and all-pole disconnection	PLe		max. SIL3

Note: All terminals in a potential group must be interference-free and it must be ensured that no energy is fed back by external circuitry, even in the event of a fault.

2 Product description

2.1 Overview EtherCAT System and Function terminals

[EL9011](#) [[▶ 21](#)] (End cap)

[EL9012](#) [[▶ 21](#)] (End cap)

[EL9070](#) [[▶ 23](#)] (Shield terminal)

[EL9080](#) [[▶ 21](#)] (Separation terminal)

[EL9100](#) [[▶ 25](#)] (Feed terminal, 24 VDC)

[EL9110](#) [[▶ 25](#)] (Feed terminal, 24 VDC, with diagnosis)

[EL9150](#) [[▶ 29](#)] (Feed terminal, 230 VAC [120 VAC])

[EL9160](#) [[▶ 29](#)] (Feed terminal, 230 VAC [120 VAC], with diagnosis)

[EL9180](#) [[▶ 32](#)] (Potential distribution terminal, 2 terminal points per power contact)

[EL9181](#) [[▶ 35](#)] (Potential distribution terminal, 2 separated potentials)

[EL9182](#) [[▶ 35](#)] (Potential distribution terminal, 8 separated potentials)

[EL9183](#) [[▶ 35](#)] (Potential distribution terminal, 1 potential, 16 terminal points)

[EL9184](#) [[▶ 39](#)] (Potential distribution terminals, 2 x 8 channels)

[EL9185](#) [[▶ 39](#)] (Potential distribution terminals, 2 x 4 channels)

[EL9185-0010](#) [[▶ 39](#)] (Potential distribution terminals, 2 x 4 channels, potential supply function up to 230 V AC)

[EL9186](#) [[▶ 39](#)], [EL9187](#) [[▶ 39](#)] (Potential distribution terminals, 8 channels)

[EL9188](#) [[▶ 39](#)], [EL9189](#) [[▶ 39](#)] (Potential distribution terminals, 16 channels)

[EL9190](#) [[▶ 25](#)] (Feed terminal, up to 230 V AC/DC)

[EL9195](#) [[▶ 49](#)] (Shield terminal, up to 230 V AC/DC)

[EL9200](#) [[▶ 52](#)] (Feed terminal, fused, 24 VDC)

[EL9210](#) [[▶ 52](#)] (Feed terminal, fused, 24 VDC, with diagnosis)

[EL9250](#) [[▶ 56](#)] (Feed terminal, fused, 230 VAC)

[EL9260](#) [[▶ 56](#)] (Feed terminal, fused, 230 VAC, with diagnosis)

[EL9290](#) [[▶ 52](#)] (Feed terminal, fused, up to 230 VAC)

[EL9400](#) [[▶ 59](#)] (Power supply unit terminal for E-bus)

[EL9410](#) [[▶ 59](#)] (Power supply unit terminal for E-bus with diagnosis)

[EL9540](#) [[▶ 62](#)] (Surge filter field supply)

[EL9540-0010](#) [[▶ 62](#)] (Surge filter field supply for analog terminals with diagnostics)

[EL9550](#) [[▶ 62](#)] (Surge filter system and field supply)

[EL9550-0010](#) [[▶ 62](#)] (Surge filter system and field supply for digital terminals with diagnostics)

[EL9550-0012](#) [[▶ 62](#)] (Surge filter system and field supply with up to 10 A)

[EL9570](#) [[▶ 72](#)] (Buffer capacitor terminal)

2.2 EL9011, EL9012, EL9080

2.2.1 EL9011, EL9012, EL9080 - Introduction and Technical Data

End cap



Fig. 7: EL9011, EL9012

Each EtherCAT terminal block must be terminated at the right-hand end with an EL9011 or EL9012 bus end cap due to mechanical and electrical protection. In addition to the E-bus, the EL9012 also covers the power contacts and is color-matched to the EL terminal series.

Separation terminal



Fig. 8: EL9080

The EL9080 separation terminal interrupts the power contacts within a bus terminal block. The terminal enables operation with different voltages on the separated sides of the power contacts. But the E-Bus is looped through. The discontinuance of the Power Contacts is especially displayed by the orange front plate of the EL9080. The EL9080 separation terminal does not have any other function or connection facility.

Technical Data	EL9011	EL9012	EL9080
Electrical isolation	-		500 V (E-bus/field potential)
Bit width in the process image	0		
Configuration	no address or configuration settings		
Diagnosis	-		
PE contact	no		
Renewed infeed	-		
Connection facility to additional power contact	-		
Side by side mounting on Bus Terminals with power contact	yes		
Side by side mounting on Bus Terminals without power contact	yes		
Electrical connection to mounting rail	no		
Weight	approx. 8 g	approx. 10 g	approx. 40 g
Permissible ambient temperature	-25°C ... +60°C (extended temperature range)		
Permissible ambient temperature range (during storage)	-40°C ... +85°C		
Permissible relative humidity	95%, no condensation		
Dimensions (W x H x D)	approx. 8 mm x 100 mm x 34 mm (width aligned: 5 mm)	approx. 8 mm x 100 mm x 55 mm (width aligned: 5 mm)	approx. 15 mm x 100 mm x 70 mm (width aligned: 12 mm)
Mounting [► 93]	aligned to the last terminal in the terminal block		on 35 mm mounting rail conforms to EN 60715
Vibration/shock resistance	conforms to EN 60068-2-6/EN 60068-2-27		
EMC resistance burst/ESD	conforms to EN 61000-6-2/EN 61000-6-4		
Protection class	IP20		
Installation position	variable		
Markings*	CE, UKCA, EAC		
Approvals*	ATEX [► 87], IECEx [► 88], cULus [► 92]	cULus [► 92]	ATEX [► 87], IECEx [► 88], cULus [► 92]

*) Real applicable approvals/markings see type plate on the side (product marking).

Ex markings

Standard	Marking
ATEX	II 3 G Ex nA IIC T4 Gc
IECEX	Ex nA IIC T4 Gc

2.3 EL9070

2.3.1 EL9070 - Introduction and Technical Data

Shield terminal

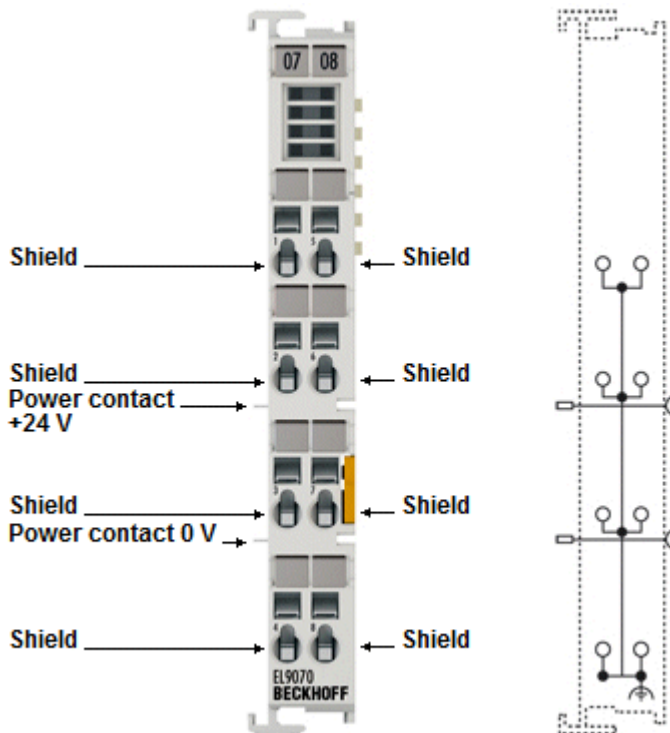

Fig. 9: EL9070

The EL9070 shield terminal provides eight terminal points with the potential of the mounting rail and enables the screening to be picked up without further modular terminal blocks or wiring. With its internal seamless copper surface, the EL9070 offers good screening between two EtherCAT Terminals.

Technical data

Technical Data		EL9070
Technology		shield terminal
Current load		≤ 10 A
Power LED		-
Error LED		-
Current consumption E-bus		-
Nominal voltage		arbitrary up to 230 V AC
Integrated fine-wire fuse		-
Electrical isolation		500 V (E-bus/field potential)
Diagnostics in the process image		-
Reported to E-bus		-
PE contact		no
Shield connection		8 x
E-bus looped through		yes
Bit width in the process image		0
Electrical connection to mounting rail		yes (dissipation of EMC interference via large copper surfaces on the mounting rail)
Electrical connection to power contacts		-
Renewed infeed		-
Connection facility to additional power contact		no
Side by side mounting on Bus Terminals with power contact		yes, left side without PE
Side by side mounting on Bus Terminals without power contact		-
Configuration		no address or configuration settings
Dimensions (W x H x D)		approx. 15 mm x 100 mm x 70 mm (width aligned: 12 mm)
Weight		approx. 50 g
Permissible ambient temperature range (during operation)		0°C ... +55°C
Permissible ambient temperature range (during storage)		-25°C ... +85°C
Permissible relative humidity		95%, no condensation
Mounting [► 93]		on 35 mm mounting rail conforms to EN 60715
Vibration / shock resistance		conforms to EN 60068-2-6 / EN 60068-2-27
EMC resistance burst / ESD		conforms to EN 61000-6-2 / EN 61000-6-4
Protection class		IP20
Installation position		variable, see chapter " Mounting of Passive Terminals [► 99] "
Approvals / markings*		CE, cULus [► 92] , UKCA, EAC

*) Real applicable approvals/markings see type plate on the side (product marking).

Connection

Terminal point		Meaning
Indication	No.	
1 - 8	1 - 8	Terminal points 1 - 8 are connected internally

2.4 EL9100, EL9110, EL9190

2.4.1 EL9100, EL9110, EL9190 - Introduction and Technical Data

Feed terminals, 24 V DC

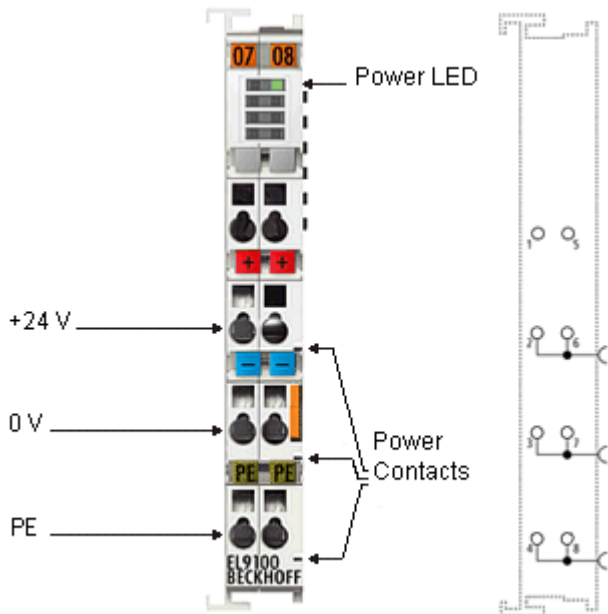

Fig. 10: EL9100

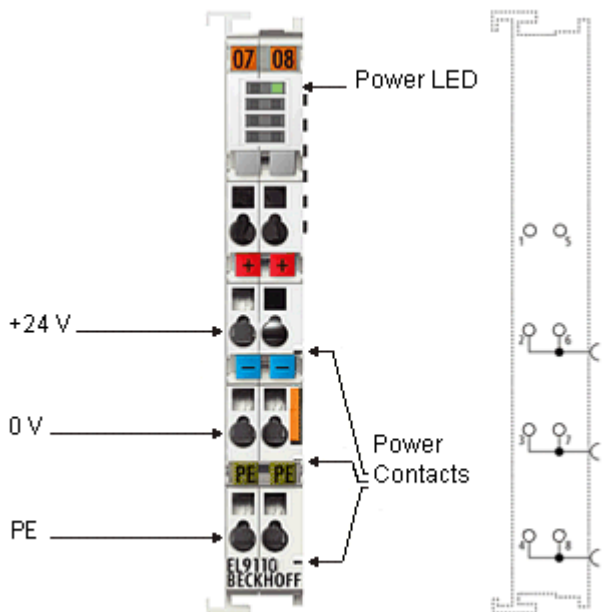

Fig. 11: EL9110

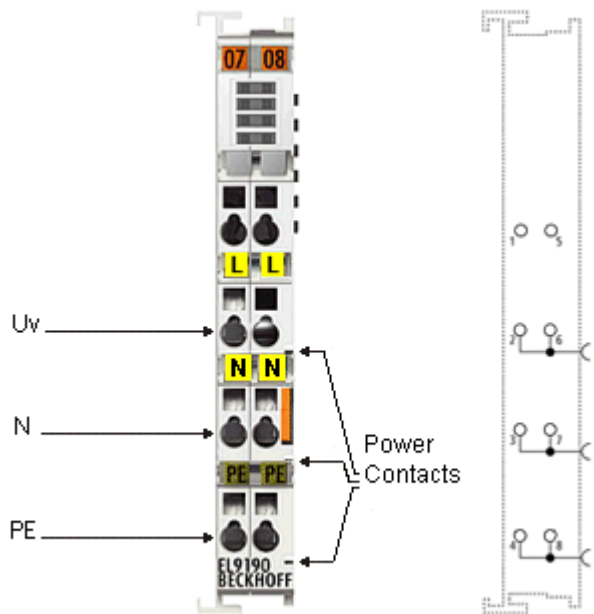

Fig. 12: EL9190

The EL9100, EL9110 and EL9190 feed terminal can be positioned at any location between the input and output terminals for establishing a further potential group or for supplying the terminals following on the right in applications with high current load. The E-Bus is looped through. As opposed to the EL9100 and EL9190, the EL9110 has a diagnostic function which is displayed on the process image.

Technical data

Technical data	EL9100	EL9110	EL9190
Nominal voltage	24 V DC		variable, up to 230 V AC/DC
Power contact current load	max. 10 A		
Electrical isolation	500 V (E-bus/field potential)		
Current consumption from E-Bus	-	typ. 90 mA	-
Bit width in the process image	-	1 bit (diagnosis)	-
Configuration	no address or configuration settings		
Power LED	yes	yes	no
Diagnosis	no	yes, in process image	no
Electrical connection to mounting rail	no		
PE contact	yes		
Renewed infeed	yes		
Connection facility to additional power contact	1		
Side by side mounting on Bus Terminals with power contact	yes		
Side by side mounting on Bus Terminals without power contact	yes		
Weight	approx. 50 g		
Permissible ambient temperature range (during operation)	-25°C ... +60°C (extended temperature range)		0°C ... +55°C
Permissible ambient temperature range (during storage)	-40°C ... +85°C		-25°C ... +85°C
Permissible relative humidity	95%, no condensation		
Dimensions (W x H x D)	approx. 15 mm x 100 mm x 70 mm (width aligned: 12 mm)		
<u>Mounting</u> [▶ 93]	on 35 mm mounting rail conforms to EN 60715		
Enhanced mechanical load capacity	yes, see <u>Installation instructions</u> [▶ 98] for enhanced mechanical load capacity		-
Vibration / shock resistance	conforms to EN 60068-2-6 / EN 60068-2-27		
EMC resistance burst / ESD	conforms to EN 61000-6-2 / EN 61000-6-4		
Protection class	IP20		
Installation position	variable, see chapter "Mounting of Passive Terminals [▶ 99]"	variable	variable, see chapter "Mounting of Passive Terminals [▶ 99]"
Approvals / markings*	CE, cULus [▶ 92], UKCA, EAC, ATEX [▶ 87], IECEx [▶ 88]		CE, cULus [▶ 92], UKCA, EAC

*) Real applicable approvals/markings see type plate on the side (product marking).

Ex markings

Standard	Marking
ATEX	II 3 G Ex nA IIC T4 Gc
IECEx	Ex nA IIC T4 Gc

Connection EL9100, EL9110, EL9190

⚠ CAUTION

Hazard to individuals and devices!

When designing a Bus Terminal block with different potentials on the power contacts (e.g. 230 V AC/DC and 24 V DC), please note that it is mandatory to use potential separation terminals (EL9080)!
Bring the bus system into a safe, powered down state before starting installation, disassembly or wiring of the Bus Terminals!

Terminal point		Description
Indication	No.	
	1	not used
+24 V* / 230 V AC/DC**	2	Supply input + 24 V [EL9100, EL9110] Supply input 230 V AC [EL9190: variable voltage, up to 230 V AC/DC] connected internally with terminal 6 and positive [EL9100, EL9110] resp. 230 V AC/DC [EL9190] power contact)
0 V* / N**	3	0 V for supply input [EL9100, EL9110] N for supply input [EL9190] connected internally with terminal 7 and negative [EL9100, EL9110] resp. neutral [EL9190] power contact)
PE***	4	PE (connected internally with terminal 8 and PE power contact)
	5	not used
+24 V* / 230 V AC/DC**	6	Supply input + 24 V [EL9100, EL9110] Supply input 230 V AC/DC [EL9190: variable voltage, up to 230 V AC/DC] connected internally with terminal 2 and positive [EL9100, EL9110] resp. 230 V AC/DC [EL9190] power contact)
0 V* / N**	7	0 V for supply input [EL9100, EL9110] N for supply input [EL9190] connected internally with terminal 3 and negative [EL9100, EL9110] resp. neutral [EL9190] power contact)
PE***	8	PE (connected internally with terminal 4 and PE power contact)

* only EL9100, EL9110

** only EL9190

*** from hardware status 02

LEDs

LED	Color	Meaning	
Power LED**	green	off	No input voltage at supply input
		on	24 V DC at supply input

** only EL9100, EL9110

Process data (only EL9110)

The EL9110 has a bit width of 1 bit (diagnosis bit for the power contacts voltage, "PowerOK") and is displayed in the TwinCAT tree as follows:

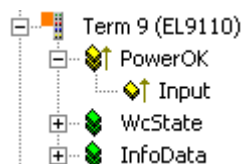

Fig. 13: EL9110 in the TwinCAT tree

If there is *no* voltage impressed on the power contacts, the corresponding diagnosis bit 'PowerOK' has FALSE (0) status.

2.5 EL9150, EL9160

2.5.1 EL9150, EL9160 - Introduction and Technical Data

Feed terminals, 230 V AC

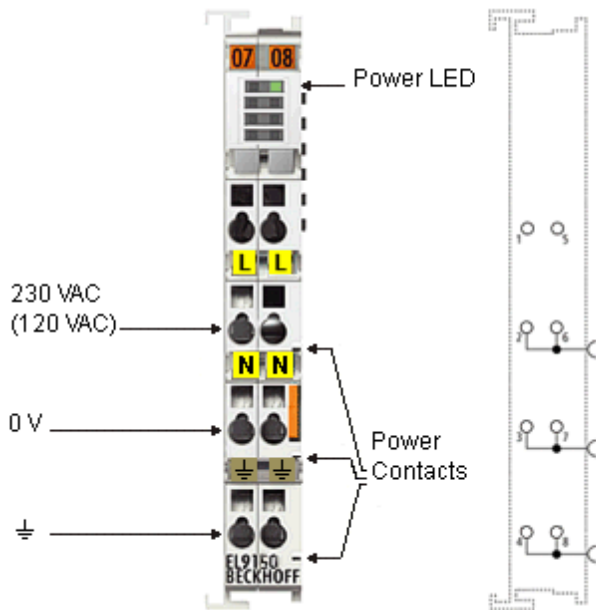

Fig. 14: EL9150

The EL9150 feed terminal can be positioned at any location between the input and output terminals for establishing a further potential group or for supplying the terminals following on the right in applications with high current load. The E-Bus is looped through.

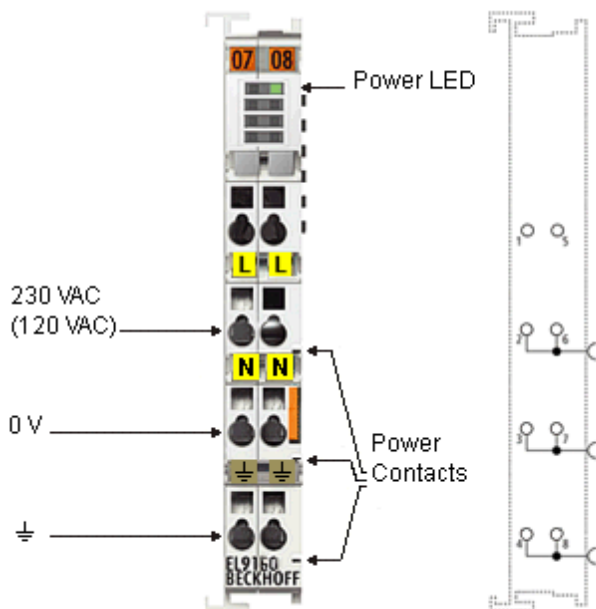

Fig. 15: EL9160

As opposed to the EL9150, the EL9160 has a diagnostic function which is displayed on the process image.

Technical data

Technical data	EL9150	EL9160
Nominal voltage	230 V _{AC} (120 V _{AC})	
Power contact current load	max. 10 A	
Electrical isolation	500 V (E-bus/field potential)	
Current consumption from E-Bus	-	typ. 90 mA
Bit width in the process image	0	1 bit (diagnosis)
Configuration	no address or configuration settings	
Power LED	yes	
Diagnosis	no	yes, in process image
Electrical connection to mounting rail	no	
PE contact	no	
Renewed infeed	yes	
Connection facility to additional power contact	1	
Side by side mounting on Bus Terminals with power contact	yes	
Side by side mounting on Bus Terminals without power contact	yes	
Weight	approx. 50 g	
Permissible ambient temperature range (during operation)	0°C ... +55°C	
Permissible ambient temperature range (during storage)	-25°C ... +85°C	
Operating height	max. 2000 m	
Overvoltage category	II	
Degree of pollution	2	
Permissible relative humidity	95%, no condensation	
Dimensions (W x H x D)	approx. 15 mm x 100 mm x 70 mm (width aligned: 12 mm)	
Mounting [► 93]	on 35 mm mounting rail conforms to EN 60715	
Vibration / shock resistance	conforms to EN 60068-2-6/EN 60068-2-27	
EMC resistance burst / ESD	conforms to EN 61000-6-2/EN 61000-6-4	
Protection class	IP20	
Installation position	variable, see chapter " Mounting of Passive Terminals [► 99] "	variable
Approvals / markings*	CE, cULus [► 92], UKCA, EAC	

*) Real applicable approvals/markings see type plate on the side (product marking).

Connection EL9150, EL9160

⚠ CAUTION

Hazard to individuals and devices!

When designing a Bus Terminal block with different potentials on the power contacts (e. g. 230 V_{AC} and 24 V_{DC}), please note that it is mandatory to use potential separation terminals (EL9080)! Bring the bus system into a safe, powered down state before starting installation, disassembly or wiring of the Bus Terminals!

Terminal point		Description
Indication	No.	
	1	not used
230 V _{AC} (120 V _{AC})	2	Supply input 230 V _{AC} (120 V _{AC}), connected internally with terminal 6 and power contact)
0 V	3	0 V for supply input (connected internally with terminal 7 and power contact)
Earth	4	Earth (connected internally with terminal 8 and earth power contact)
	5	not used
230 V _{AC} (120 V _{AC})	6	Supply input 230 V _{AC} (120 V _{AC}), (connected internally with terminal 2 and power contact)
0 V	7	0 V for supply input (connected internally with terminal 3 and power contact)
Earth	8	Earth (connected internally with terminal 4 and earth power contact)

LEDs

LED	Color	Meaning	
Power LED	green	off	No input voltage at supply input
		on	230 V _{AC} (120 V _{AC}) at supply input

Process data (only EL9160)

The EL9160 has a bit width of 1 bit (diagnosis bit for the power contacts voltage, "PowerOK") and is displayed in the TwinCAT tree as follows:

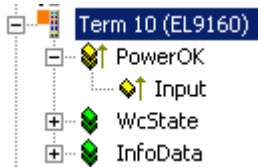

Fig. 16: EL9160 in the TwinCAT tree

If there is no voltage impressed on the power contacts, the corresponding diagnosis bit 'PowerOK' has FALSE (0) status.

2.6 EL9180

2.6.1 EL9180 - Introduction and Technical Data

Potential distribution terminal

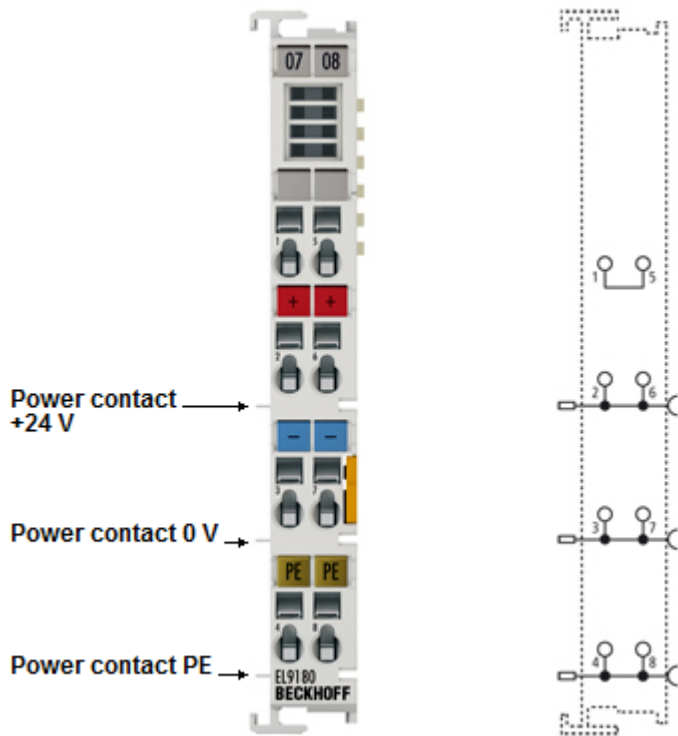

Fig. 17: EL9080

The EL9180 allows the supply voltage to be accessed a number of times via spring force terminals. The EtherCAT Terminal makes it unnecessary to use additional terminal blocks on the terminal strip.

Technical data

Technical data	EL9180
Technology	potential distribution terminal
Power contact current load	≤ 10 A
Power LED	-
Defect LED	-
Current consumption from E-Bus	-
Nominal voltage	arbitrary up to 230 V AC/DC
Integrated fine-wire fuse	-
Electrical isolation	500 V (E-bus/field potential)
Diagnosis	-
Reported to E-bus	-
Power contact	3 x power contact
PE contact	yes
Shield connection	-
Renewed infeed	-
Connection facility to additional power contact	2
Side by side mounting on Bus Terminals with power contact	yes
Side by side mounting on Bus Terminals without power contact	-
Electrical connection to mounting rail	yes
Bit width in the process image	-
Configuration	no address or configuration settings
Weight	approx. 50 g
Permissible ambient temperature range (during operation)	0°C ... +55°C
Permissible ambient temperature range (during storage)	-25°C ... +85°C
Permissible relative humidity	95%, no condensation
Dimensions (W x H x D)	approx. 15 mm x 100 mm x 70 mm (width aligned: 12 mm)
Mounting [► 93]	on 35 mm mounting rail conform to EN 60715
Enhanced mechanical load capacity	yes, see Installation instructions [► 98] for enhanced mechanical load capacity
Vibration / shock resistance	conforms to EN 60068-2-6 / EN 60068-2-27
EMC resistance burst / ESD	conforms to EN 61000-6-2 / EN 61000-6-4
Protection class	IP20
Installation position	variable, see chapter " Mounting of Passive Terminals [► 99] "
Approvals / markings ^{*)}	CE, cULus [► 92] , UKCA, EAC, ATEX [► 86] , IECEx [► 88]

*) Real applicable approvals/markings see type plate on the side (product marking).

Ex markings

Standard	Marking
ATEX	II 3 G Ex nA IIC T4 Gc
IECEx	Ex nA IIC T4 Gc

Connection EL9180

Terminal point No.	Description
1	connected internally with terminal 5
2	+24 V (connected internally with terminal 6 and positive power contact)
3	0 V (connected internally with terminal 7 and negative power contact)
4	PE (connected internally with terminal 8 and PE power contact)
5	connected internally with terminal 1
6	+24 V (connected internally with terminal 2 and positive power contact)
7	0 V (connected internally with terminal 3 and negative power contact)
8	PE (connected internally with terminal 4 and PE power contact)

2.7 EL9181, EL9182, EL9183

2.7.1 EL9181, EL9182, EL9183 - Introduction and Technical Data

Potential distribution terminal, HD housing

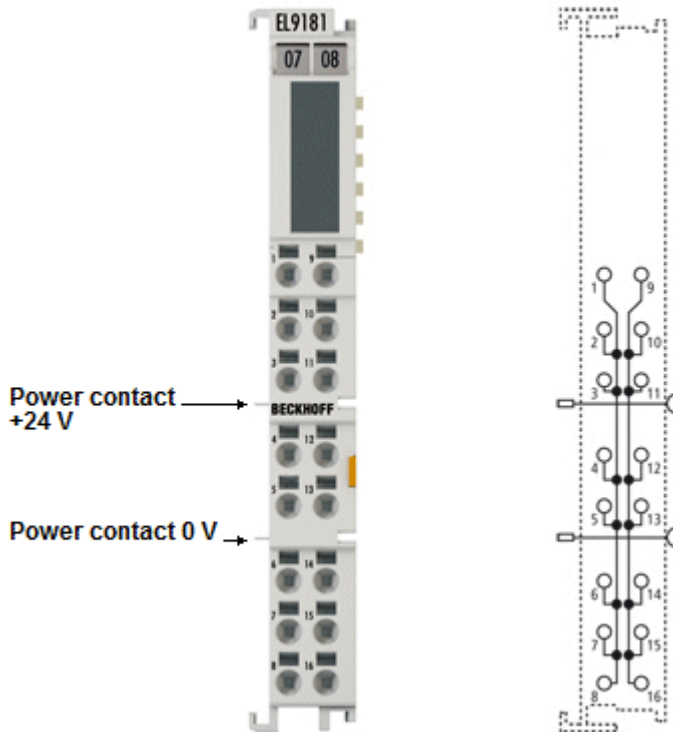

Fig. 18: EL9181

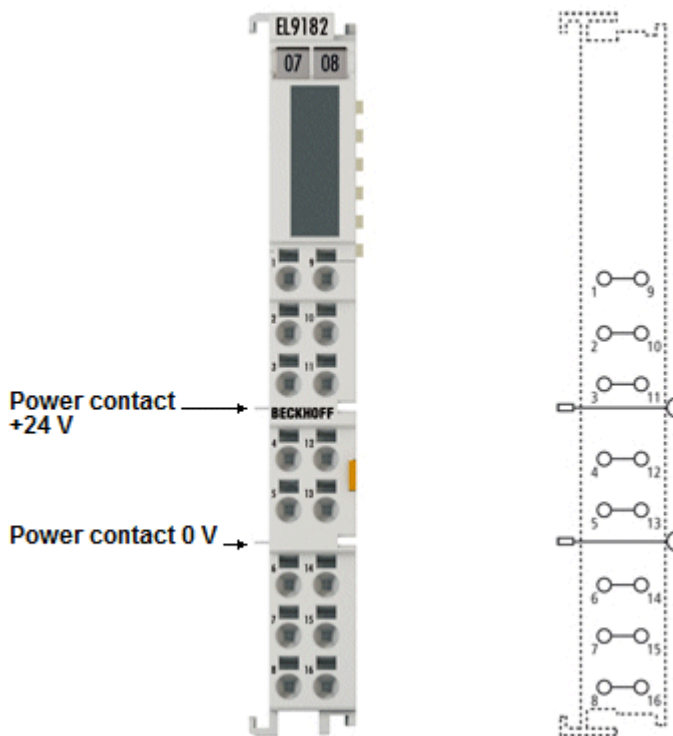

Fig. 19: EL9182

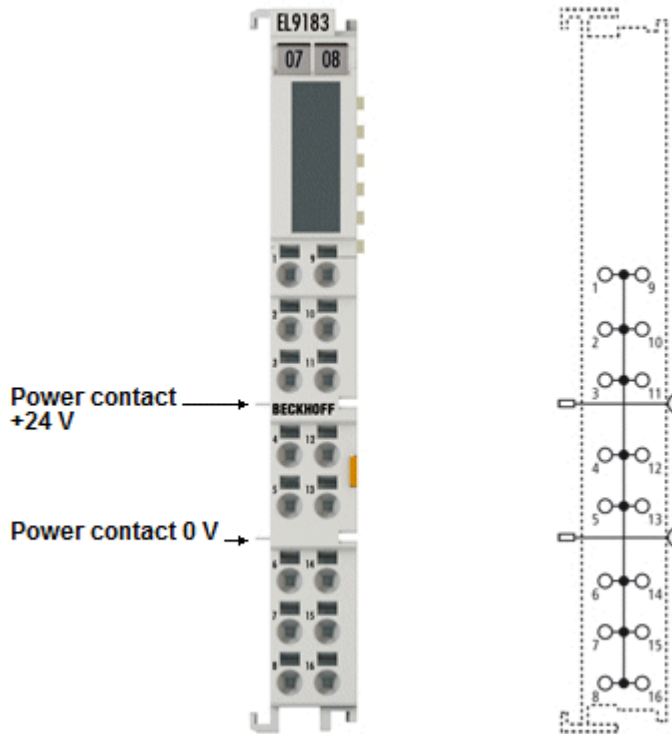

Fig. 20: EL9183

The potential distribution terminals EL9181, EL9182 and EL9183 provide 16 terminal points for potential distribution and enable the voltage to be picked up without further terminal blocks or wiring. The power contacts are fed through to the next terminal without connecting to the terminal points.

The HD EtherCAT Terminals (High Density) with increased packing density feature 16 connection points in the housing of a 12 mm EtherCAT Terminal. The conductors can be connected without tools in the case of solid wires using a direct plug-in technique

Technical data

Technical Data	EL9181	EL9182	EL9183
Technology	Potential distribution terminal		
Number of separate potentials	2	8	1
Terminal points per potential	8	2	16
Nominal voltage	≤ 60 V _{DC}		
Current load	max. 10 A		
Current consumption from E-Bus	-		
E-bus looped through	yes		
Power contacts looped through	yes (2 power contacts)		
Diagnosis	-		
Message to E-Bus	-		
PE contact	no		
Renewed infeed	-		
Connection facility to additional power contact	-		
Side by side mounting on Bus Terminals with power contact	yes		
Side by side mounting on Bus Terminals without power contact	-		
Bit width in the process image	0		
Electrical connection to mounting rail	-		
Electrical connection to power contacts	-		
Electrical isolation	500 V (E-bus/field potential)		
Configuration	no address or configuration settings		
Conductor types	solid wire, stranded wire and ferrule		
Conductor connection	solid wire conductors: direct plug-in technique; stranded wire conductors and ferrules: spring actuation by screwdriver		
Rated cross-section	solid wire: 0.08...1.5 mm ² ; stranded wire: 0.25...1.5 mm ² ; ferrule: 0.14...0.75 mm ²		
Weight	approx. 60 g		
Permissible ambient temperature range (during operation)	-25°C ... +60°C (extended temperature range)		
Permissible ambient temperature range (during storage)	-40°C ... +85°C		
Permissible relative humidity	95%, no condensation		
Dimensions (W x H x D)	approx. 15 mm x 100 mm x 70 mm (width aligned: 12 mm)		
Mounting [▶ 93]	on 35 mm mounting rail conforms to EN 60715		
Enhanced mechanical load capacity	yes, see Installation instructions [▶ 98] for enhanced mechanical load capacity		
Vibration / shock resistance	conforms to EN 60068-2-6 / EN 60068-2-27		
EMC resistance burst / ESD	conforms to EN 61000-6-2 / EN 61000-6-4		
Protection class	IP20		
Installation position	variable, see chapter " Mounting of Passive Terminals [▶ 99]"		
Approvals / markings*	CE, cULus [▶ 92], UKCA, EAC, ATEX [▶ 87], IECEx [▶ 88],		CE, cULus [▶ 92], UKCA, EAC,

*) Real applicable approvals/markings see type plate on the side (product marking).

Ex markings

Standard	Marking
ATEX	II 3 G Ex nA IIC T4 Gc
IECEx	Ex nA IIC T4 Gc

Connection EL9181

Terminal point		Meaning
Indication	No.	
1 - 8	1 - 8	Terminal points 1 - 8 are connected internally
9 - 16	9 - 16	Terminal points 9 - 16 are connected internally

Connection EL9182

Terminal point		Meaning
Indication	No.	
1, 9	1 + 9	Terminal points 1 + 9 are connected internally
2, 10	2 + 10	Terminal points 2 + 10 are connected internally
3, 11	3 + 11	Terminal points 3 + 11 are connected internally
4, 12	4 + 12	Terminal points 4 + 12 are connected internally
5, 13	5 + 13	Terminal points 5 + 13 are connected internally
6, 14	6 + 14	Terminal points 6 + 14 are connected internally
7, 15	7 + 15	Terminal points 7 + 15 are connected internally
8, 16	8 + 16	Terminal points 8 + 16 are connected internally

Connection EL9183

Terminal point		Meaning
Indication	No.	
1 - 16	1 - 16	Terminal points 1 - 16 are connected internally

2.8 EL9184, EL9185, EL9185-0010, EL9186, EL9187, EL9188, EL9189

2.8.1 EL9184, EL9185, EL9185-0010, EL9186, EL9187, EL9188, EL9189 - Introduction and Technical Data

Potential distribution terminals

EL9185

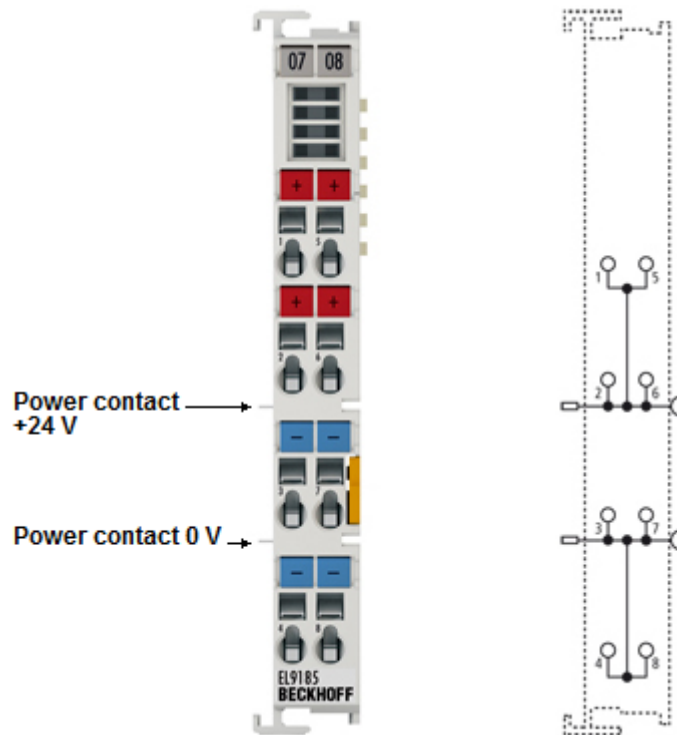

Fig. 21: EL9185

The EL9185 EtherCAT Terminal allows the supply voltage to be accessed a number of times via spring force terminals. The EL9185 makes it unnecessary to use additional terminal blocks on the terminal strip.

Technical data

Technical Data	EL9185
Nominal voltage	arbitrary up to 230 V AC/DC
Current load	≤ 10 A
Diagnosis	-
Message to E-Bus	-
PE contact	no
Shield connection	-
Current consumption from E-Bus	-
Bit width in the process image	0
Electrical connection to mounting rail	-
Electrical isolation	500 V (E-bus/field potential)
Renewed infeed	-
Side by side mounting on EtherCAT Terminals with power contact	only 2 power contacts, no PE
Side by side mounting on EtherCAT Terminals without power contact	-
Connection facility to additional power contact	4
Configuration	no address or configuration settings
Weight	approx. 65 g
Permissible ambient temperature range (during operation)	-25°C ... +60°C (extended temperature range)
Permissible ambient temperature range (during storage)	-40°C ... +85°C
Permissible relative humidity	95%, no condensation
Dimensions (W x H x D)	approx. 15 mm x 100 mm x 70 mm (width aligned: 12 mm)
Mounting [▶ 93]	on 35 mm mounting rail conforms to EN 60715
Enhanced mechanical load capacity	yes, see Installation instructions [▶ 98] for enhanced mechanical load capacity
Vibration / shock resistance	conforms to EN 60068-2-6 / EN 60068-2-27
EMC resistance burst / ESD	conforms to EN 61000-6-2 / EN 61000-6-4
Protection class	IP20
Installation position	variable, see chapter " Mounting of Passive Terminals [▶ 99] "
Approvals / markings*	CE, cULus [▶ 92] , UKCA, EAC, ATEX [▶ 87] , IECEx [▶ 88]

*) Real applicable approvals/markings see type plate on the side (product marking).

Ex markings

Standard	Marking
ATEX	II 3 G Ex nA IIC T4 Gc
IECEx	Ex nA IIC T4 Gc

Connection EL9185

Terminal point		Description
Indication	No.	
Output 1, 2, 5, 6	1, 2, 5, 6	Output 1, 2, 5, 6 (internally connected with positive power contact)
Output 3, 4, 7, 8	3, 4, 7, 8	Output 3, 4, 7, 8 (internally connected with negative power contact)

EL9185-0010

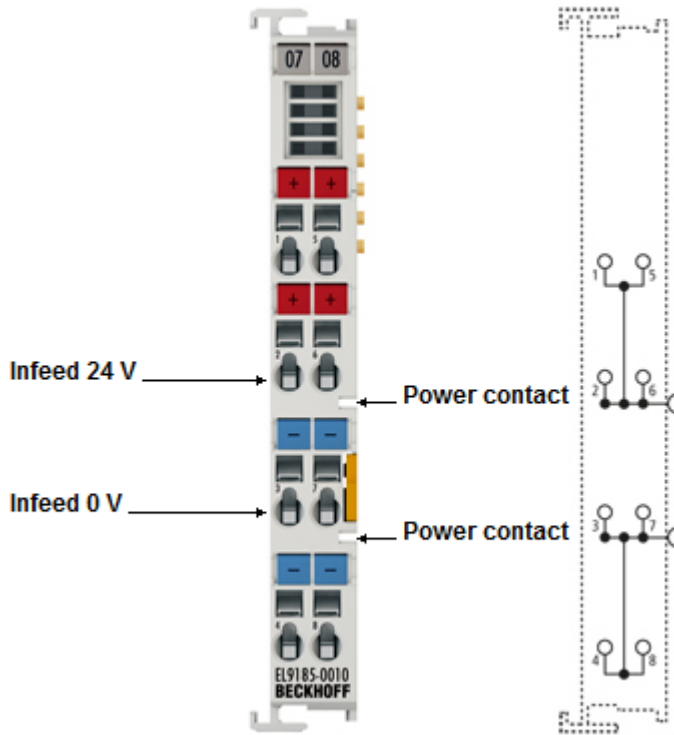

Fig. 22: EL9185-0010

The EL9185-0010 potential distribution terminal with additional power feed function enables multiple tapping of the supply voltage at the terminal points. In addition, it feeds in the supply voltage for the downstream terminals via power contacts and as a result forms a new potential group, as no power contacts are fed out on the left side of the EL9185-0010. The EL9185-0010 makes the use of additional terminal blocks on the terminal strip unnecessary.

Technical data

Technical Data	EL9185-0010
Nominal voltage	arbitrary up to 230 V AC/DC
Current load	≤ 10 A
Diagnosis	-
Message to E-Bus	-
PE contact	no
Shield connection	-
Current consumption from E-Bus	-
Bit width in the process image	0
Electrical connection to mounting rail	-
Electrical isolation	500 V (E-bus/field potential)
Renewed infeed	yes
Side by side mounting on EtherCAT Terminals with power contact	yes
Side by side mounting on EtherCAT Terminals without power contact	yes
Connection facility to additional power contact	3
Configuration	no address or configuration settings
Weight	approx. 65 g
Permissible ambient temperature range (during operation)	0°C ... +55°C
Permissible ambient temperature range (during storage)	-25°C ... +85°C
Permissible relative humidity	95%, no condensation
Dimensions (W x H x D)	approx. 15 mm x 100 mm x 70 mm (width aligned: 12 mm)
<u>Mounting</u> [► 93]	on 35 mm mounting rail conforms to EN 60715
Enhanced mechanical load capacity	yes, see <u>Installation instructions</u> [► 98] for enhanced mechanical load capacity
Vibration / shock resistance	conforms to EN 60068-2-6 / EN 60068-2-27
EMC resistance burst / ESD	conforms to EN 61000-6-2 / EN 61000-6-4
Protection class	IP20
Installation position	variable, see chapter " <u>Mounting of Passive Terminals</u> [► 99]"
Approvals / markings*	CE, UKCA, EAC

*) Real applicable approvals/markings see type plate on the side (product marking).

Connection EL9185-0010

Terminal point		Description
Indication	No.	
Output 1, 2, 5, 6	1, 2, 5, 6	Output 1, 2, 5, 6 (internally connected with positive power contact, right-sided)
Output 3, 4, 7, 8	3, 4, 7, 8	Output 3, 4, 7, 8 (internally connected with negative power contact, right-sided)

EL9186, EL9187

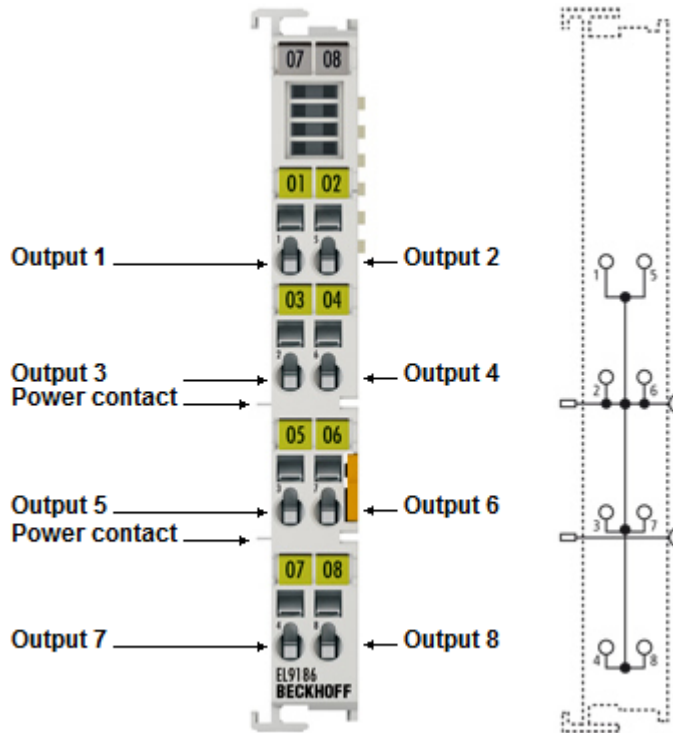

Fig. 23: EL9186

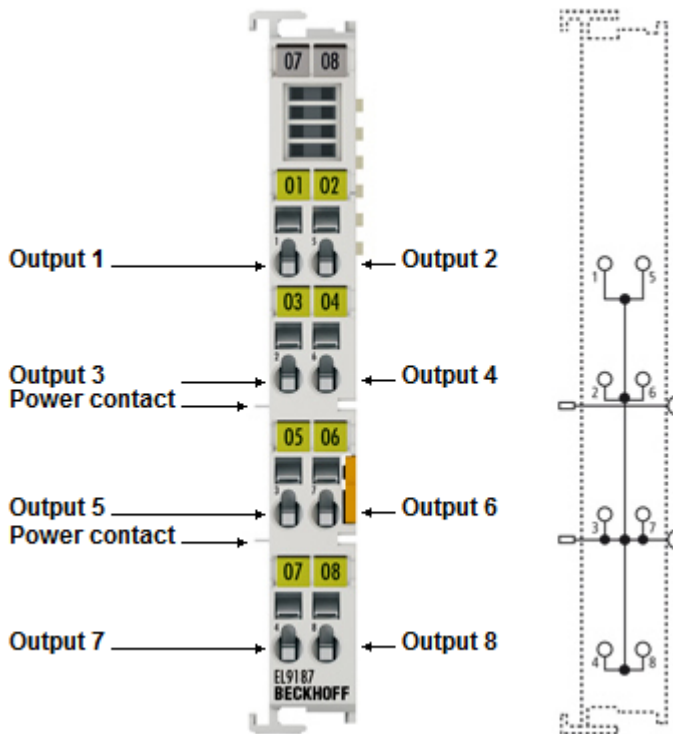

Fig. 24: EL9187

The potential distribution terminals EL9186 and EL9187 provide 8 terminal points with a potential and enable the voltage to be picked up without further bus terminal blocks or wiring.

Technical Data

Technical Data	EL9186	EL9187
Nominal voltage	≤ 60V DC / ≤ 30V AC	
Current load	≤ 10 A	
Diagnosis	-	
Message to E-Bus	-	
PE contact	no	
Shield connection	-	
Outputs	8 (connected with positive power contact)	8 x 0 V contact (connected with negative power contact)
Current consumption from E-Bus	-	
Bit width in the process image	0	
Electrical connection to mounting rail	-	
Electrical isolation	500 V (E-bus/field potential)	
Renewed power feed	-	
Side by side mounting on EtherCAT Terminals with power contact	yes, left side without PE	
Side by side mounting on EtherCAT Terminals without power contact	-	
Connection facility to additional power contact	8	
Configuration	no address or configuration settings	
Weight	approx. 65 g	
Permissible ambient temperature range (during operation)	-25°C ... +60°C (extended temperature range)	
Permissible ambient temperature range (during storage)	-40°C ... +85°C	
Permissible relative humidity	95%, no condensation	
Dimensions (W x H x D)	approx. 15 mm x 100 mm x 70 mm (width aligned: 12 mm)	
Mounting [► 93]	on 35 mm mounting rail conforms to EN 60715	
Enhanced mechanical load capacity	yes, see Installation instructions [► 98] for enhanced mechanical load capacity	
Vibration / shock resistance	conforms to EN 60068-2-6 / EN 60068-2-27	
EMC resistance burst / ESD	conforms to EN 61000-6-2 / EN 61000-6-4	
Protection class	IP20	
Installation position	variable, see chapter " Mounting of Passive Terminals [► 99] "	
Approvals / markings*	CE, cULus [► 92] , UKCA, EAC, ATEX [► 87] , IECEx [► 88]	

*) Real applicable approvals/markings see type plate on the side (product marking).

Ex markings

Standard	Marking
ATEX	II 3 G Ex nA IIC T4 Gc
IECEX	Ex nA IIC T4 Gc

Connection EL9186

Terminal point		Description
Indication	No.	
Output 1 - 8	1 - 8	Output 1 - 8 (internally connected with positive power contact)

Connection EL9187

Terminal point		Description
Indication	No.	
Output 1 - 8	1 - 8	Output 1 - 8 (internally connected with negative power contact)

Potential distribution terminals, HD housing

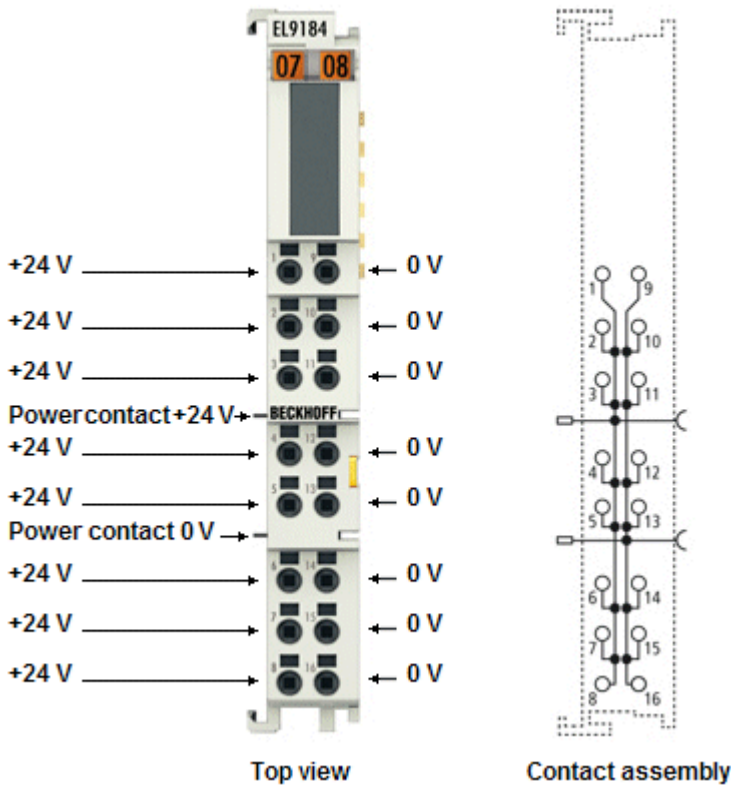

Fig. 25: EL9184

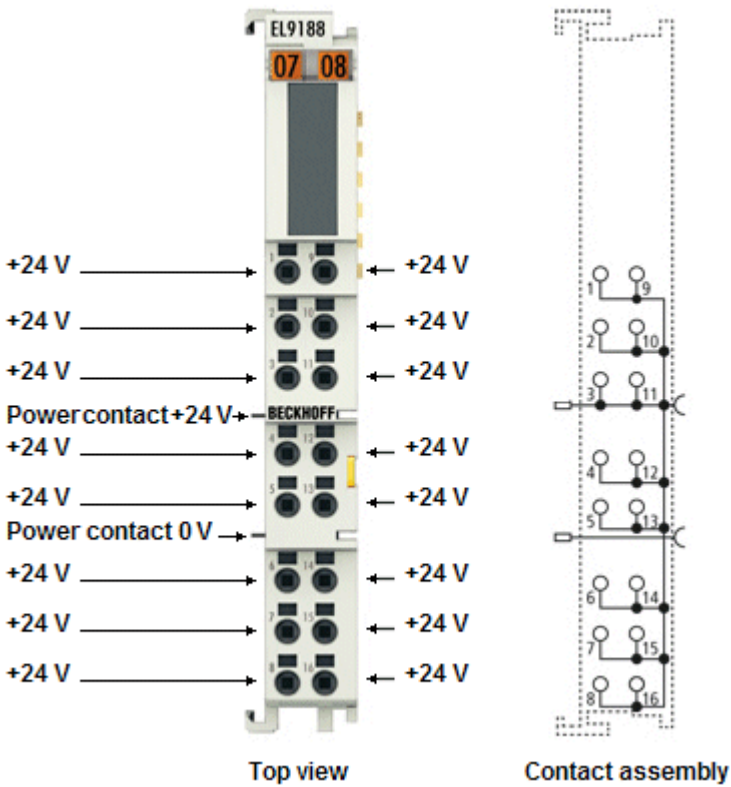

Fig. 26: EL9188

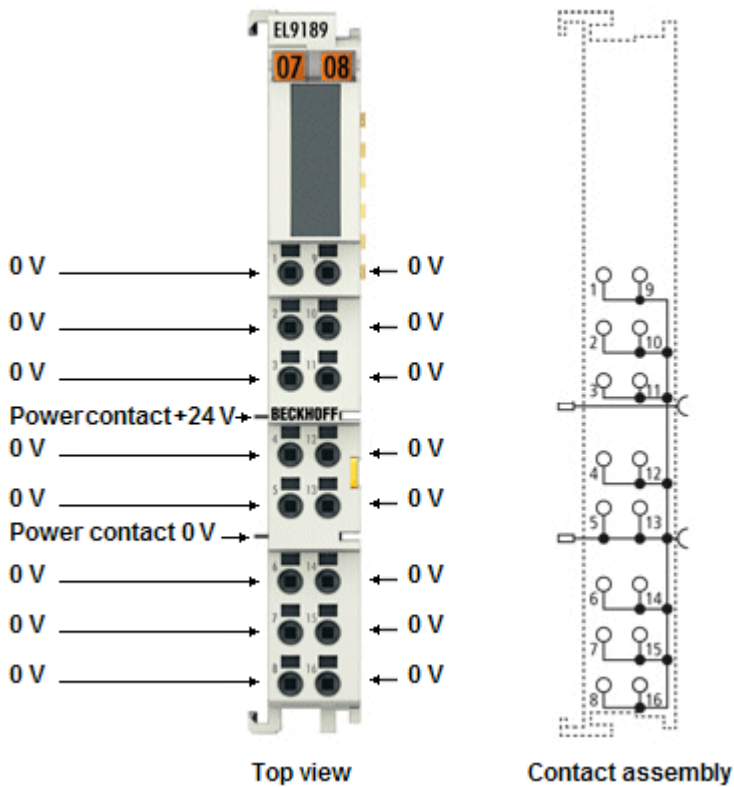

Fig. 27: EL9189

The potential distribution terminals EL9188 and EL9189 provide 16 terminal points with a potential and enable the voltage to be picked up without further bus terminal blocks or wiring. The EL9184 provides the potential of the 24 V DC contact at 8 terminal points and the potential of the 0 V contact at 8 terminal points.

The conductors can be connected without tools in the case of solid wires using a direct plug-in technique.

The HD EtherCAT Terminals (High Density) with increased packing density feature 16 connection points in the housing of a 12 mm terminal block.

Technical Data

Technical Data	EL9184	EL9188	EL9189
Nominal voltage	≤ 60 V _{DC}		
Current load	≤ 10 A		
Power LED	-		
Error LED	-		
Message to E-Bus	-		
Shield connection	-		
Renewed power feed	-		
Connection facility to additional power contact	8	16	
Side by side mounting on EtherCAT Terminals with power contact	yes, left side without PE		
Side by side mounting on EtherCAT Terminals without power contact	-		
PE contact	no		
Outputs	2 x 8 (e.g.: 8 x 24 V contact, 8 x 0 V contact)	16 (e.g. 16 x 24 V contact)	16 (e.g. 16 x 0 V contact)
Current consumption from E-Bus	-		
Bit width in the process image	0		
Electrical connection to mounting rail	-		
Electrical isolation	500 V (E-bus/field potential)		
Configuration	no address or configuration settings		
Conductor types	solid wire, stranded wire and ferrule		
Conductor connection	solid wire conductors: direct plug-in technique; stranded wire conductors and ferrules: spring actuation by screwdriver		
Rated cross-section	solid wire: 0.08...1.5 mm ² ; stranded wire: 0.25...1.5 mm ² ; ferrule: 0.14...0.75 mm ²		
Weight	approx.. 60 g		
Permissible ambient temperature range (during operation)	-25°C ... +60°C (extended temperature range)		
Permissible ambient temperature range (during storage)	-40°C ... +85°C		
Permissible relative humidity	95%, no condensation		
Dimensions (W x H x D)	approx. 15 mm x 100 mm x 70 mm (width aligned: 12 mm)		
Mounting [▶ 93]	on 35 mm mounting rail conforms to EN 60715		
Enhanced mechanical load capacity	yes, see Installation instructions [▶ 98] for enhanced mechanical load capacity		
Vibration / shock resistance	conforms to EN 60068-2-6 / EN 60068-2-27		
EMC resistance burst / ESD	conforms to EN 61000-6-2 / EN 61000-6-4		
Protection class	IP20		
Installation position	variable, see chapter "Mounting of Passive Terminals [▶ 99] "		
Approvals / markings*	CE, cULus [▶ 92] , UKCA, EAC, ATEX [▶ 87] , IECEx [▶ 88]		

*) Real applicable approvals/markings see type plate on the side (product marking).

Ex markings

Standard	Marking
ATEX	II 3 G Ex nA IIC T4 Gc
IECEx	Ex nA IIC T4 Gc

Connection EL9184

Terminal point		Description
Indication	No.	
+24 V	1 - 8	+24 V output (internally connected with positive power contact)
0 V	9 - 16	0 V (internally connected with negative power contact)

Connection EL9188

Terminal point		Description
Indication	No.	
+24 V	1 - 16	+24 V output (internally connected with positive power contact)

Connection EL9189

Terminal point		Description
Indication	No.	
0 V	1 - 16	0 V (internally connected with negative power contact)

2.9 EL9195

2.9.1 EL9195 - Introduction and Technical Data

Shield terminal

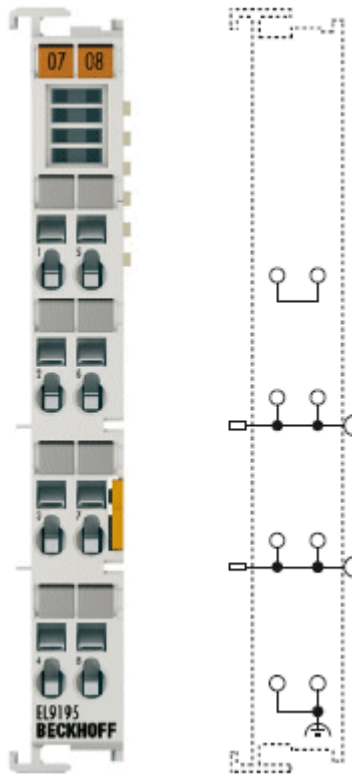

Fig. 28: EL9195

The EL9195 shield terminal enables the connection of the shield from the front via two terminal contacts, which are connected directly to the DIN rail, in order to be able to optimally dissipate electromagnetic irradiation.

The multiple tapping of the supply voltage via the front-side terminal contacts is additionally ensured by the EL9195 EtherCAT terminal. 24 V and 0 V can each be tapped twice from the front. The power contacts are connected to the front-side terminal contacts and are passed through to the adjacent terminal. With the EL9195, the use of additional terminal blocks on the terminal strip can be reduced.

Technical data

Technical data	EL9195
Technology	shield terminal, for dissipation of EMC interference
Power contact current load	max. 10 A
Power LED	-
Defect LED	-
Current consumption from E-Bus	-
Nominal voltage	arbitrary up to 230 V AC/DC
Integrated fine-wire fuse	-
Electrical isolation	500 V (E-bus/field potential)
Diagnosis	-
Reported to E-bus	-
Power contact	2 x power contact
PE contact	-
Renewed infeed	-
Connection facility to additional power contact	2
Side by side mounting on Bus Terminals with power contact	only 2 power contacts
Side by side mounting on Bus Terminals without power contact	-
Shield connection	2 x
Electrical connection to mounting rail	yes
Bit width in the process image	0
Configuration	no address or configuration settings
Weight	approx. 50 g
Permissible ambient temperature range (during operation)	0°C ... +55°C
Permissible ambient temperature range (during storage)	-25°C ... +85°C
Permissible relative humidity	95%, no condensation
Dimensions (W x H x D)	approx. 15 mm x 100 mm x 70 mm (width aligned: 12 mm)
Mounting [▶ 93]	on 35 mm mounting rail conform to EN 60715
Enhanced mechanical load capacity	yes, see Installation instructions [▶ 98] for enhanced mechanical load capacity
Vibration / shock resistance	conforms to EN 60068-2-6 / EN 60068-2-27
EMC resistance burst / ESD	conforms to EN 61000-6-2 / EN 61000-6-4
Protection class	IP20
Installation position	variable, see chapter " Mounting of Passive Terminals [▶ 99]"
Approvals / markings*	CE, cULus [▶ 92], UKCA, EAC, ATEX [▶ 86], IECEX [▶ 88],

*) Real applicable approvals/markings see type plate on the side (product marking).

Ex markings

Standard	Marking
ATEX	II 3 G Ex nA IIC T4 Gc
IECEX	Ex nA IIC T4 Gc

Connection EL9195

⚠ CAUTION

Hazard to individuals and devices!

When designing a Bus Terminal block with different potentials on the power contacts (e. g. 230 V_{AC} and 24 V_{DC}), please note that it is mandatory to use potential separation terminals (EL9080)!
Bring the bus system into a safe, powered down state before starting installation, disassembly or wiring of the Bus Terminals!

Terminal point No.	Description
1	connected internally with terminal 5
2	Supply input: variable voltage, up to 230 V AC/DC connected internally with terminal 6 and positive resp. phase power contact)
3	0 V / N connected internally with terminal 7 and negative resp. neutral power contact)
4	Shield (connected internally with terminal 8 and mounting rail contact)
5	connected internally with terminal 1
6	Supply input: variable voltage, up to 230 V AC/DC connected internally with terminal 6 and positive resp. phase power contact)
7	0 V / N connected internally with terminal 3 and negative resp. neutral power contact)
8	Shield (connected internally with terminal 8 and mounting rail contact)

2.10 EL9200, EL9210, EL9290

2.10.1 EL9200, EL9210, EL9290 - Introduction and Technical Data

Feed terminals, 24 V DC

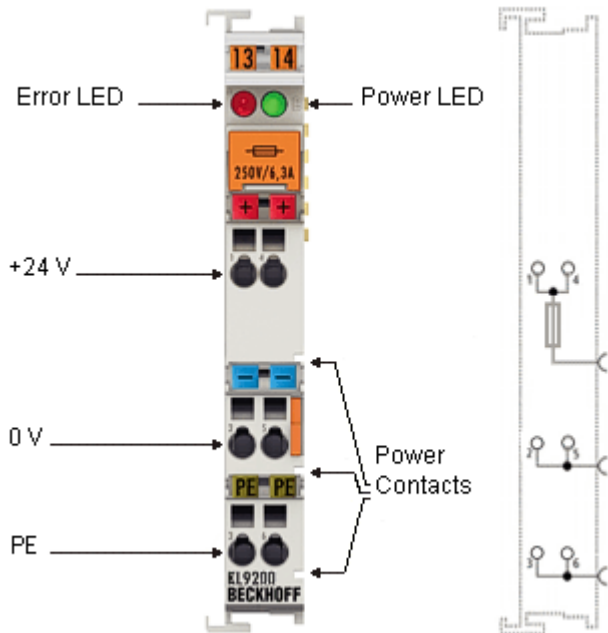

Fig. 29: EL9200

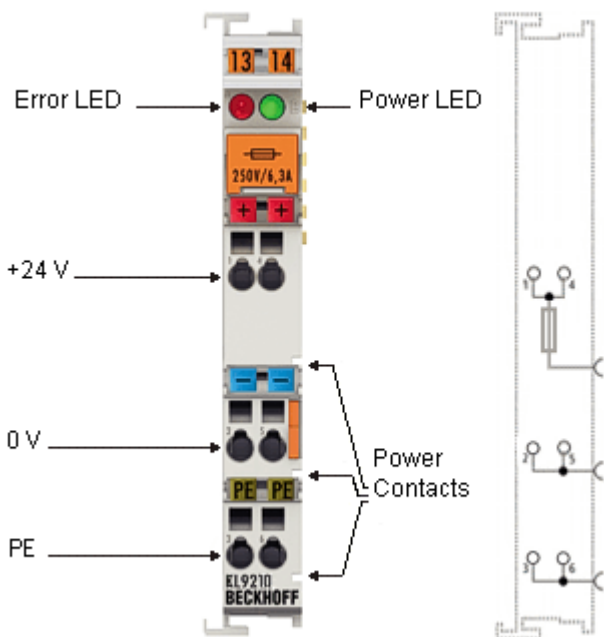

Fig. 30: EL9210

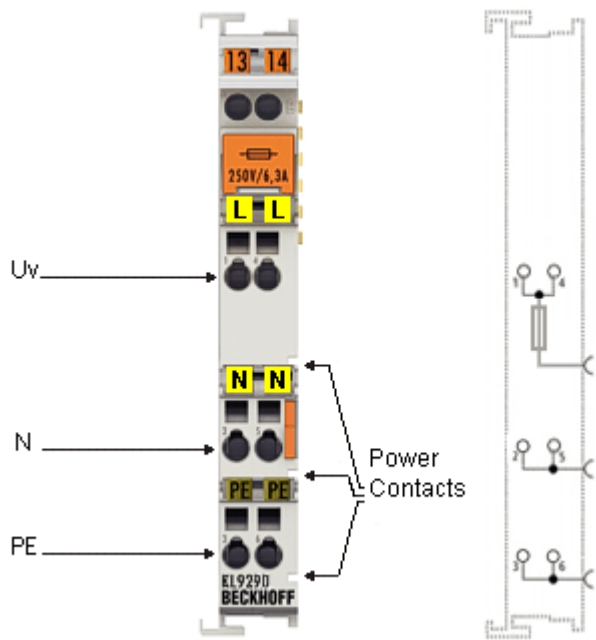

Fig. 31: EL9290

The EL9200, EL9210 and EL9290 feed terminals can be positioned at any location between the input and output terminals for establishing a further potential group or for supplying the terminals following on the right in applications with high current load. The E-Bus is looped through. As opposed to the EL9200 and EL9290, the EL9210 has a diagnostic function which is displayed on the process image. The feed-in is protected by a 6.3 A fine-wire fuse at all terminals.

Technical data

Technical data	EL9200	EL9210	EL9290
Nominal voltage	24 V _{DC}		variable, up to 230 V AC
Power contact current load	max. 10 A		
Electrical isolation	500 V (E-bus/field potential)		
Integrated fine-wire fuse	yes; 6.3 A		
Current consumption from E-Bus	-	typ. 90 mA	-
Bit width in the process image	-	2 diagnostic bits (PowerOK; FuseError)	-
Configuration	no address or configuration settings		
Power LED	yes	yes	no
Diagnosis (fuse)	yes, Error LED	yes, in process image and ErrorLED	no
Electrical connection to mounting rail	no		
PE contact	yes		
Renewed infeed	yes		
Connection facility to additional power contact	1		
Side by side mounting on Bus Terminals with power contact	yes		
Side by side mounting on Bus Terminals without power contact	yes		
Weight	approx. 55 g		
Permissible ambient temperature range (during operation)	0°C ... +55°C		
Permissible ambient temperature range (during storage)	-25°C ... +85°C		
Permissible relative humidity	95%, no condensation		
Dimensions (W x H x D)	approx. 15 mm x 100 mm x 70 mm (width aligned: 12 mm)		
Mounting [▶ 93]	on 35 mm mounting rail conforms to EN 60715		
Vibration / shock resistance	conforms to EN 60068-2-6 / EN 60068-2-27		
EMC resistance burst / ESD	conforms to EN 61000-6-2 / EN 61000-6-4		
Protection class	IP 20		
Installation position	variable, see chapter " Mounting of Passive Terminals ▶ 99 "	variable	variable, see chapter " Mounting of Passive Terminals ▶ 99 "
Markings*	CE, UKCA, EAC		
Approvals*	cULus ▶ 92 , ATEX ▶ 86 , IECEX ▶ 88 ,	cULus ▶ 92 , DNV GL, ATEX ▶ 86 , IECEX ▶ 88 ,	-

*) Real applicable approvals/markings see type plate on the side (product marking).

Ex markings

Standard	Marking
ATEX	II 3 G Ex nA IIC T4 Gc
IECEX	Ex nA IIC T4 Gc

Connection EL9200, EL9210, EL9290

⚠ CAUTION

Hazard to individuals and devices!

When designing a Bus Terminal block with different potentials on the power contacts (e. g. 230 V_{AC} and 24 V_{DC}), please note that it is mandatory to use potential separation terminals (EL9080)!
Bring the bus system into a safe, powered down state before starting installation, disassembly or wiring of the Bus Terminals!

Terminal point		Description
Indication	No.	
+24 V* / 230 V AC**	1	Supply input + 24 V [EL9200, EL9210] Supply input 230 V AC [EL9290: variable voltage, up to 230 V AC] connected internally with terminal 4 and positive [EL9200, EL9210] resp. 230 V AC [EL9290] power contact)
0 V* / N**	2	0 V for supply input [EL9200, EL9210] N for supply input [EL9290] connected internally with terminal 5 and negative [EL9200, EL9210] resp. neutral [EL9290] power contact)
PE	3	PE (connected internally with terminal 6 and PE power contact)
+24 V* / 230 V AC**	4	Supply input + 24 V [EL9200, EL9210] Supply input 230 V AC [EL9290: variable voltage, up to 230 V AC] connected internally with terminal 1 and positive [EL9200, EL9210] resp. 230 V AC [EL9290] power contact)
0 V* / N**	5	0 V for supply input [EL9200, EL9210] N for supply input [EL9290] connected internally with terminal 2 and negative [EL9200, EL9210] resp. neutral [EL9290] power contact)
PE	6	PE (connected internally with terminal 3 and PE power contact)

* only EL9200, EL9210

** only EL9290

LEDs

LED	Color	Meaning	
		State	Meaning
Power LED**	green	off	No input voltage at supply input
		on	24 V _{DC} at supply input
Error LED**	red	off	Fuse OK
		on	Fuse error

** only EL9200, EL9210

Process data (only EL9210)

The EL 9210 has a bit width of 2 bits (diagnosis bit for the power contacts voltage, "PowerOK" and diagnosis bit for fuse error, "FuseError") and is displayed in the TwinCAT tree as follows:

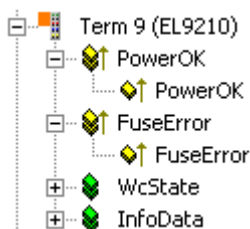

Fig. 32: EL9210 in the TwinCAT tree

If there is no voltage impressed on the power contacts, the corresponding diagnosis bit 'PowerOK' has FALSE (0) status.

If there is a fuse error, the corresponding diagnosis bit 'FuseError' has TRUE (1) status.

2.11 EL9250, EL9260

2.11.1 EL9250, EL9260 - Introduction and Technical Data

Feed terminals, 230 V AC

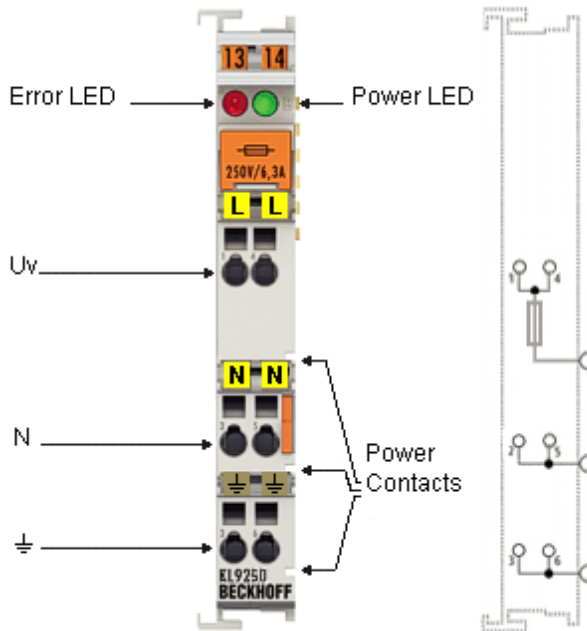

Fig. 33: EL9250

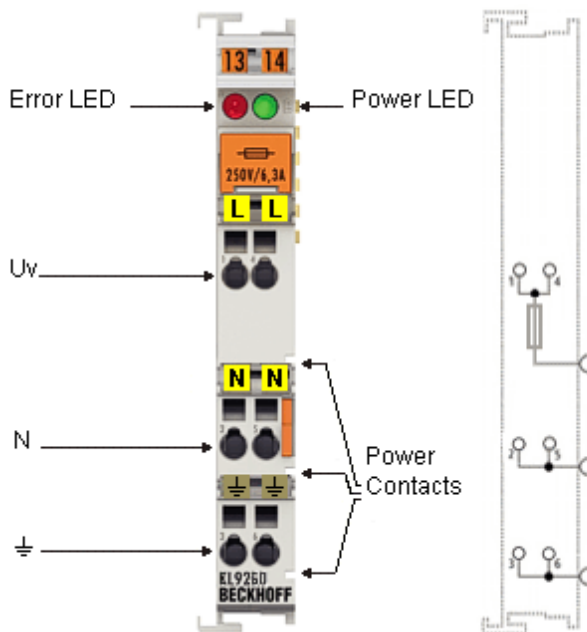

Fig. 34: EL9260

The EL9250 and EL9260 feed terminal can be positioned at any location between the input and output terminals for establishing a further potential group or for supplying the terminals following on the right in applications with high current load. The E-Bus is looped through. As opposed to the EL9250, the EL9260 has a diagnostic function which is displayed on the process image. The feed-in is protected by a 6.3 A fine-wire fuse at all terminals.

Technical data

Technical data	EL9250	EL9260
Nominal voltage	230 V AC	
Power contact current load	max. 10 A	
Electrical isolation	500 V (E-bus/field potential)	
Integrated fine-wire fuse	yes; 6.3 A (see also UL note [► 92!])	
Current consumption from E-Bus	-	typ. 90 mA
Bit width in the process image	-	2 bit (diagnosis)
Configuration	no address or configuration settings	
Power LED	yes	
Diagnosis (fuse)	yes, Error LED	yes, in process image and Error LED
Electrical connection to mounting rail	no	
PE contact	yes	
Renewed infeed	yes	
Connection facility to additional power contact	1	
Side by side mounting on Bus Terminals with power contact	yes	
Side by side mounting on Bus Terminals without power contact	yes	
Weight	approx. 55 g	
Permissible ambient temperature range (during operation)	0°C ... +55°C	
Permissible ambient temperature range (during storage)	-25°C ... +85°C	
Operating height	max. 2000 m	
Overvoltage category	II	
Degree of pollution	2	
Permissible relative humidity	95%, no condensation	
Dimensions (W x H x D)	approx. 15 mm x 100 mm x 70 mm (width aligned: 12 mm)	
Mounting [► 93]	on 35 mm mounting rail conforms to EN 60715	
Vibration / shock resistance	conforms to EN 60068-2-6 / EN 60068-2-27	
EMC resistance burst / ESD	conforms to EN 61000-6-2 / EN 61000-6-4	
Protection class	IP20	
Installation position	variable, see chapter " Mounting of Passive Terminals [► 99] "	variable
Approvals / markings*	CE, UKCA, EAC,	

*) Real applicable approvals/markings see type plate on the side (product marking).

Connection EL9250, EL9260

⚠ CAUTION
<p>Hazard to individuals and devices!</p> <p>When designing a Bus Terminal block with different potentials on the power contacts (e. g. 230 V_{AC} and 24 V_{DC}), please note that it is mandatory to use potential separation terminals (EL9080)! Bring the bus system into a safe, powered down state before starting installation, disassembly or wiring of the Bus Terminals!</p>

Terminal point		Description
Indication	No.	
230 V AC	1	Supply input 230 V AC; connected internally with terminal 4 and 230 V AC power contact)
N	2	N for supply input; connected internally with terminal 5 and neutral power contact)
Earth	3	Earth; connected internally with terminal 6 and earth power contact)
230 V AC	4	Supply input 230 V AC; connected internally with terminal 1 and 230 V AC power contact)
N	5	N for supply input; connected internally with terminal 2 and neutral power contact)
Earth	6	Earth; connected internally with terminal 3 and earth power contact)

LEDs

LED	Color	Meaning	
Power LED	green	off	No input voltage at supply input
		on	230 V AC at supply input
Error LED	red	off	Fuse OK
		on	Fuse error

Process data (only EL9260)

The EL9260 has a bit width of 2 bits (diagnosis bit for the power contacts voltage, "PowerOK" and diagnosis bit for fuse error, "FuseError") and is displayed in the TwinCAT tree as follows:

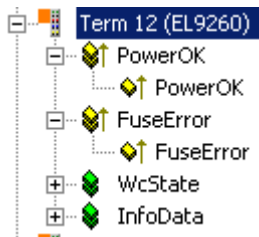

Fig. 35: EL9260 in the TwinCAT tree

If there is no voltage impressed on the power contacts, the corresponding diagnosis bit 'PowerOK' has FALSE (0) status.

If there is a fuse error, the corresponding diagnosis bit 'FuseError' has TRUE (1) status.

2.12 EL9400, EL9410

2.12.1 EL9400, EL9410 - Introduction and Technical Data

Power supply terminals

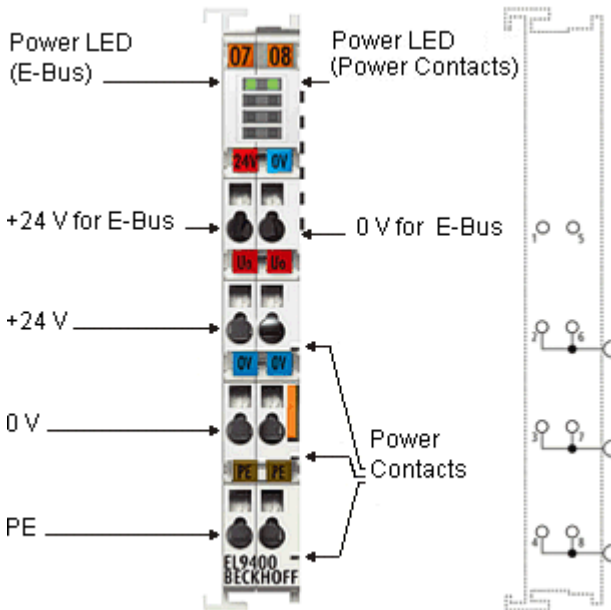

Fig. 36: EL9400

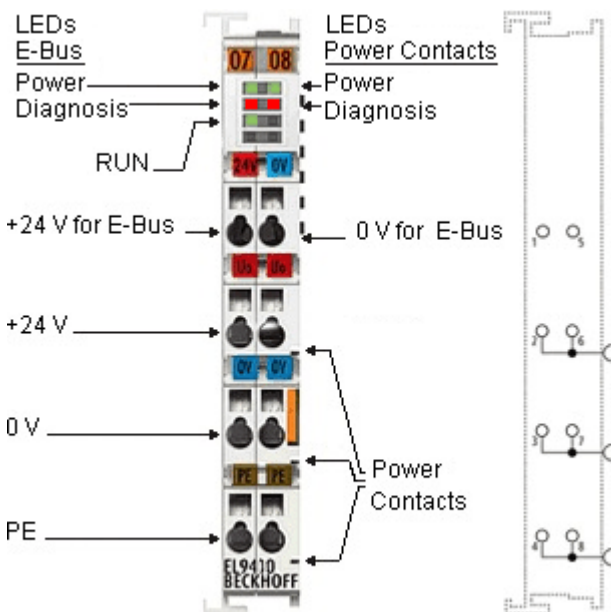

Fig. 37: EL9410

The EL9400 and EL9410 power supply terminals are used to refresh the E-bus.

Data is exchanged between the coupler and the EtherCAT Terminal over the E-bus. Each terminal draws a certain amount of current from the E-bus (see “current consumption E-bus” in the technical data). This current is fed into the E-bus by the relevant coupler’s power supply unit. In configurations with many terminals, it is possible to use the EL9400/EL9410 in order to supply an extra 2 A to the E-bus. As opposed to the EL9400, the EL9410 has a diagnostic function which is displayed by LED and on the process image. At the same time the EL9400/EL9410 can establish another potential group by an external 24 V feed-in via the power contacts on the right side.

Technical Data

Technical Data	EL9400	EL9410
Input voltage	24 V _{DC}	
Output current for E-bus supply	2 A	
Power contact voltage	24 V _{DC}	
Power contact current load	max. 10 A	
Current consumption from E-Bus	-	-
Electrical isolation	500 V (E-bus/field potential)	
Diagnosis	no	yes, via LED and in the process image
Electrical connection to mounting rail	no	
PE contact	yes	
Renewed infeed	yes	
Connection facility to additional power contact	1	
Side by side mounting on Bus Terminals with power contact	yes	
Side by side mounting on Bus Terminals without power contact	yes	
Bit width in the process image	-	2 bits (diagnosis)
Configuration	no address or configuration settings	
Weight	approx. 65 g	
Permissible ambient temperature range (during operation)	0°C ... +55°C	
Permissible ambient temperature range (during storage)	-25°C ... +85°C	
Permissible relative humidity	95%, no condensation	
Dimensions (W x H x D)	approx. 15 mm x 100 mm x 70 mm (width aligned: 12 mm)	
Mounting [▶ 93]	on 35 mm mounting rail conforms to EN 60715	
Enhanced mechanical load capacity	yes, see Installation instructions [▶ 98] for enhanced mechanical load capacity	
Vibration / shock resistance	conforms to EN 60068-2-6 / EN 60068-2-27	
EMC resistance burst / ESD	conforms to EN 61000-6-2 / EN 61000-6-4	
Protection class	IP20	
Installation position	variable, see chapter " Mounting of Passive Terminals " [▶ 99]"	variable
Approvals / markings*	CE, cULus [▶ 92], UKCA, EAC, ATEX [▶ 86], IECEx [▶ 88]	

*) Real applicable approvals/markings see type plate on the side (product marking).

Ex markings

Standard	Marking
ATEX	II 3 G Ex nA IIC T4 Gc
IECEx	Ex nA IIC T4 Gc

Connection EL9400, EL9410

Terminal point		Description
Indication	No.	
+24 V for E-Bus	1	Supply input + 24 V for the E-Bus
+24 V	2	Supply input + 24 V (connected internally with terminal 6 and positive power contact)
0 V	3	0 V for supply input (connected internally with terminal 7 and negative power contact)
PE	4	PE (connected internally with terminal 8)
0 V for E-Bus	5	0 V for supply input E-Bus
+24 V	6	Supply input + 24 V (connected internally with terminal 2 and positive power contact)
0 V	7	0 V for supply input (connected internally with terminal 3 and negative power contact)
PE	8	PE (connected internally with terminal 4)

LEDs

LED	Color	Meaning	
Power LED (E-Bus)	green	off	No input voltage at supply input for the E-Bus
		on	24 V _{DC} at supply input for the E-Bus
Power LED (Power Contacts)	green	off	No input voltage at supply input
		on	24 V _{DC} at supply input
Diagnosis LED** Us	red	off	No error
		on	Undervoltage: Us less than 17 V
Diagnosis LED** Up	red	off	No error
		on	Undervoltage: Up less than 17 V
RUN	green	This LED indicates the terminal's operating state:	
		off	State of the EtherCAT State Machine: INIT = Initialization of the terminal
		flashing (2 Hz)	State of the EtherCAT State Machine: PREOP = Setting for mailbox communication and variant standard settings
		flashing (1 Hz)	State of the EtherCAT State Machine: SAFEOP = Channel checking of the Sync Manager and the Distributed Clocks. Outputs stay in safe operation mode.
		on	State of the EtherCAT State Machine: OP = Normal operation mode, mailbox- and process data communication possible
		flashing (10 Hz)	State of the EtherCAT State Machine: BOOTSTRAP = Function for e. g. firmware updates of the terminal

** only EL9410

Process data (only EL9410)

The EL 9410 has a bit width of 2 bits (diagnosis bits for the power contacts voltage [Up] and for the E-Bus voltage [Us], 'Undervoltage') and is displayed in the TwinCAT tree as follows:

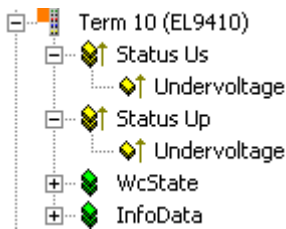

Fig. 38: EL9410 in the TwinCAT tree

If the Up or Us voltage is below 17 V, the corresponding diagnosis bit 'Undervoltage' has TRUE (1) status.

2.13 EL9540, EL9540-0010, EL9550, EL9550-0010, EL9550-0012

2.13.1 EL9540, EL9540-0010, EL9550, EL9550-0010, EL9550-0012 - Introduction and Technical Data

Surge filter terminals

The surge filter terminals protect the EtherCAT Terminals from conducted Surge voltages, as they can be caused on the supply lines by high-energy, dynamic disturbance variables, e. g. switching overvoltages with inductive loads or overvoltage with indirect lightning strikes.

The EL9540, EL9550 and EL9550-0012 EtherCAT Terminals enable the terminal station to be protected against damage in particularly harsh environments, such as in the on- and offshore area.

The EL9540-0010 is particularly suitable for the protection of analog terminals, the EL9550-0010 for digital terminals, and can be used, for example, in shipbuilding.

The EL954x have a filter for the 24 V DC field supply and the EL955x have a filter for the 24 V DC field and system supply.

For the EL9550-0012 variant, the current load for both the field supply and the system supply is 10 A each. For the EL9550-0010, the total field and system supply is 10 A. The higher system supply is advantageous for the supply of Embedded PCs, which have a higher current consumption.

Technical data

Technical data	EL9540	EL9540-0010	EL9550	EL9550-0010	EL9550-0012
Function	surge filter field supply		surge filter system and field supply		
Nominal voltage	24 V (-15 %/+20 %)				
Surge filter field supply	yes				
Surge filter system supply	-		yes		
Rated current field supply	≤ 10 A	≤ 5 A	≤ 10 A	up to 10 A, field+system in total 10 A	≤ 10 A
Rated current system supply	-		≤ 1.5 A (from hardware version 03)	up to 10 A, field+system in total 10 A	≤ 10 A
Diagnostics	-	yes	-	yes	-
Reported to E-Bus	-	yes	-	yes	-
PE contact	yes	no	-	no	-
Shield connection	-				
Current consumption E-bus	-	typ. 40 mA	-	typ. 40 mA	-
Bit width in the process image	-	2	-	4	-
Connection to mounting rail	-				
Electrical isolation	500 V (E-bus/field potential)				
Renewed infeed	-	yes	-	yes	-
Connection facility to additional power contact	2	1			
Side by side mounting on EtherCAT Terminals with power contact	yes				
Side by side mounting on EtherCAT Terminals without power contact	-	yes			
Dimensions (B x H x T)	approx. 15 mm x 100 mm x 70 mm (width aligned: 12 mm)				
Configuration	no address- or configuration setting necessary				
Weight	approx. 50 g				
Permissible ambient temperature range (during operation)	-25°C ... +60°C (extended temperature range)	0°C ... +55°C	-25°C ... +60°C (extended temperature range)	0°C ... +55°C	
Permissible ambient temperature range (during storage)	-40°C ... +85°C	-25°C ... +85°C	-40°C ... +85°C	-25°C ... +85°C	
Permissible relative humidity	95%, no condensation				
<u>Mounting</u> [▶ 93]	on 35 mm mounting rail conforms to EN 60715				
Enhanced mechanical load capacity	yes, see <u>Installation instructions</u> [▶ 98] for enhanced mechanical load capacity				
Vibration / shock resistance	conforms to EN 60068-2-6 / EN 60068-2-27				
EMC resistance burst / ESD	conforms to EN 61000-6-2 / EN 61000-6-4				
Protection class	IP20				
Installation position	variable, see chapter " <u>Mounting of Passive Terminals</u> [▶ 99]"				
Markings*	CE, UKCA, EAC				
Approvals*	cULus [▶ 92], ATEX [▶ 87], IECEX [▶ 88]	DNV GL, ATEX [▶ 86], IECEX [▶ 88]	cULus [▶ 92], ATEX [▶ 87], IECEX [▶ 88], cFMus [▶ 90]	DNV GL	-

*) Real applicable approvals/markings see type plate on the side (product marking).

Ex markings

Standard	Marking
ATEX	II 3 G Ex nA IIC T4 Gc
IECEX	Ex nA IIC T4 Gc
cFMus	Class I, Division 2, Groups A, B, C, D Class I, Zone 2, AEx/Ex ec IIC T4 Gc

LEDs and connection EL9540

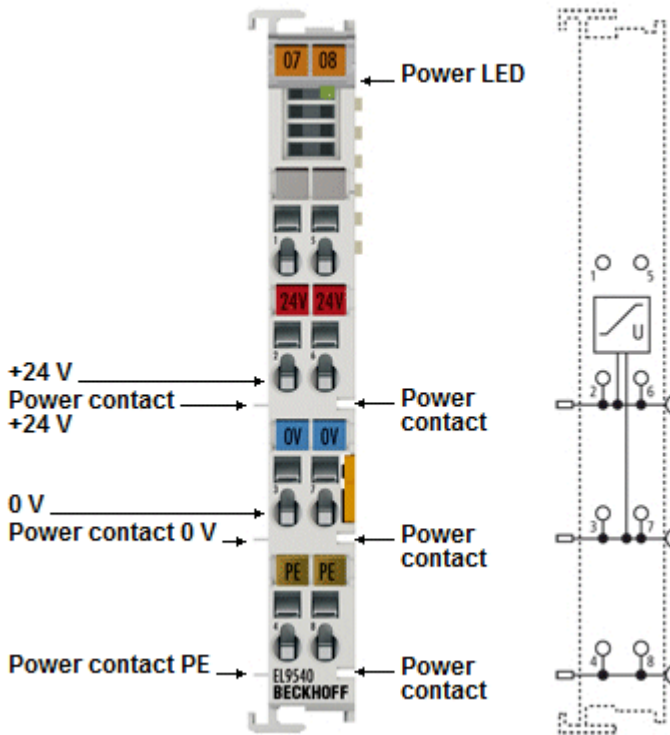

Fig. 39: EL9540

LED	Color	Meaning	
Power-LED	green	off	24 V _{DC} field supply not present
		on	24 V _{DC} field supply present

Terminal point		Description
Indication	No.	
n.c.	1	not connected
+24 V	2	+24 V (internally connected with terminal point 6 and positive power contact)
0 V	3	0 V (internally connected with terminal point 7 and negative power contact)
PE	4	PE (internally connected with terminal point 8 and PE power contact)
n.c.	5	not connected
+24 V	6	+24 V (internally connected with terminal point 2 and positive power contact)
0 V	7	0 V (internally connected with terminal point 3 and negative power contact)
PE	8	PE (internally connected with terminal point 4 and PE power contact)

LEDs and connection EL9540-0010

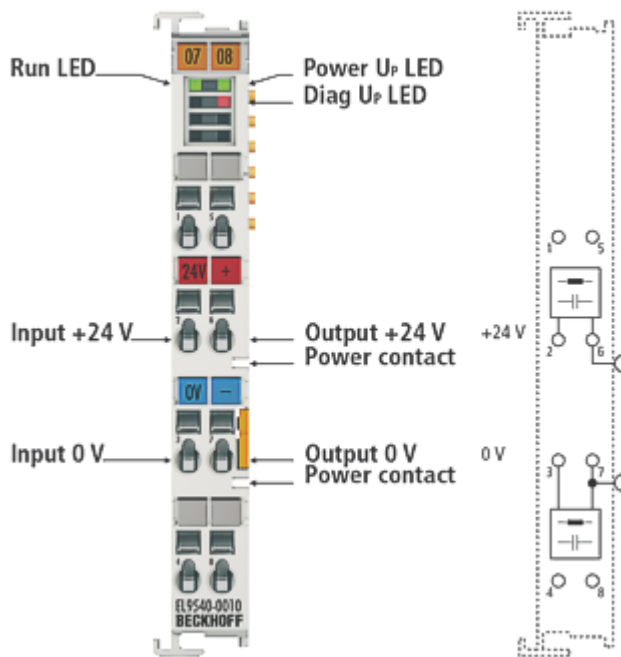

Fig. 40: EL9540-0010

LED	Color	Meaning	
Power Up LED	green	off	no voltage
		on	OK
Diagnosis LED	red	off	no error
		on	Undervoltage: U_p below 18 V
RUN	green	This LED indicates the terminal's operating state:	
		off	State of the EtherCAT State Machine: INIT = Initialization of the terminal
		flashing (2 Hz)	State of the EtherCAT State Machine: PREOP = Setting for mailbox communication and variant standard settings
		flashing (1 Hz)	State of the EtherCAT State Machine: SAFEOP = Channel checking of the Sync Manager and the Distributed Clocks. Outputs stay in safe operation mode.
		on	State of the EtherCAT State Machine: OP = Normal operation mode, mailbox- and process data communication possible
		flashing (10 Hz)	State of the EtherCAT State Machine: BOOTSTRAP = Function for e.g. firmware updates of the terminal

Terminal point		Description
Indication	No.	
n.c.	1	not connected
+24 V Input	2	+ 24 V Input
0 V Input	3	0 V Input
n.c.	4	not connected
n.c.	5	not connected
+24 V Output	6	+ 24 V Output
0 V Output	7	0 V Output
n.c.	8	not connected

Process data EL9540-0010

The EL9540-0010 has a bit width of 2 bits [diagnostic bits for undervoltage ("Undervoltage") and overvoltage ("Overvoltage")] in the process image and is represented in the TwinCAT tree as follows:

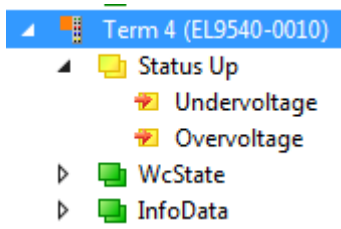

Fig. 41: EL9540-0010 in TwinCAT tree

LEDs and connection EL9550/EL9550-0012

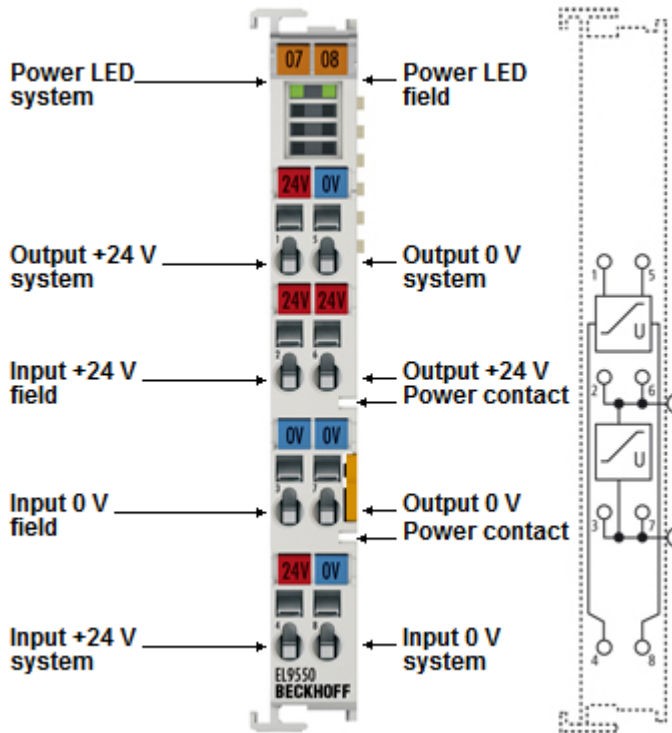

Fig. 42: EL9550, EL9550-0012

LED	Color	Meaning	
Power-LED field	green	off	24 V _{DC} field supply not present
		on	24 V _{DC} field supply present
Power-LED system	green	off	24 V _{DC} system supply not present
		on	24 V _{DC} system supply present

Terminal point		Description
Indication	No.	
Output +24 V system	1	Output +24 V (system)
Input +24 V field	2	Input +24 V (field) (internally connected with terminal point 6 and positive power contact)
Input 0 V field	3	Input 0 V (field) (internally connected with terminal point 7 and negative power contact)
Input +24 V system	4	Input +24 V (system)
Output 0 V system	5	Output 0 V (system)
Input +24 V field	6	24 V (field) (internally connected with terminal point 2 and positive power contact)
Input 0 V field	7	0 V (field) (internally connected with terminal point 3 and negative power contact)
Input 0 V system	8	Input 0 V (system)

LEDs and connection EL9550-0010

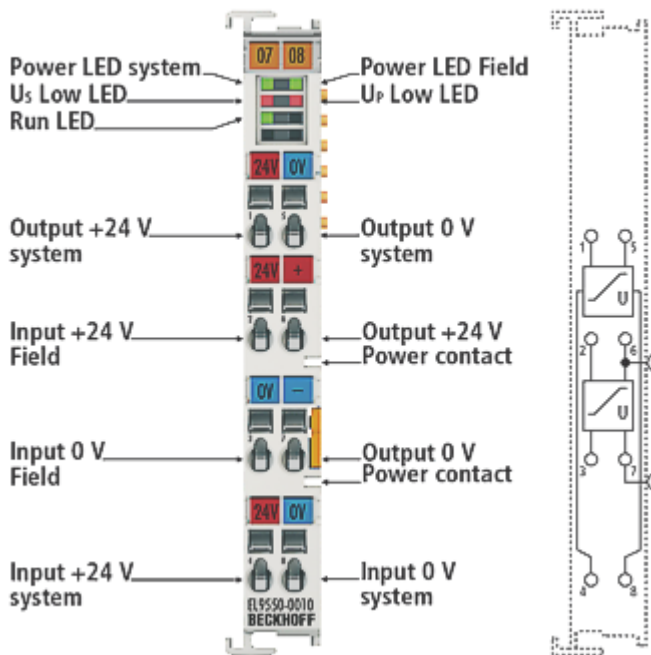

Fig. 43: EL9550-0010

LED	Color	Meaning	
Power-LED system	green	off	24 V _{DC} system supply not present
		on	24 V _{DC} system supply present
Power-LED field	green	off	24 V _{DC} field supply not present
		on	24 V _{DC} field supply present
Us Low LED	red	off	no error
		on	Undervoltage, Us below 18 V
Up Low LED	red	off	no error
		on	Undervoltage, Up below 18 V
RUN	green	This LED indicates the terminal's operating state:	
		off	State of the EtherCAT State Machine: INIT = Initialization of the terminal
		flashing (2 Hz)	State of the EtherCAT State Machine: PREOP = Setting for mailbox communication and variant standard settings
		flashing (1 Hz)	State of the EtherCAT State Machine: SAFEOP = Channel checking of the Sync Manager and the Distributed Clocks. Outputs stay in safe operation mode.
		on	State of the EtherCAT State Machine: OP = Normal operation mode, mailbox- and process data communication possible
		flashing (10 Hz)	State of the EtherCAT State Machine: BOOTSTRAP = Function for e.g. firmware updates of the terminal

Terminal point		Meaning
Indication	No.	
Output +24 V system	1	Output +24 V (system)
Input +24 V field	2	Input +24 V (field)
Input 0 V field	3	Input 0 V (field)
Input +24 V system	4	Input +24 V (system)
Output 0 V system	5	Output 0 V (system)
Input +24 V field	6	24 V (field) (internally connected with positive power contact)
Input 0 V field	7	0 V (field) (internally connected with negative power contact)
Input 0 V system	8	Input 0 V (system)

Process data EL9550-0010

The EL9550-0010 has a bit width of 4 bits (diagnostic bits for Up/Us undervoltage and overvoltage) in the process image and is represented in the TwinCAT tree as follows:

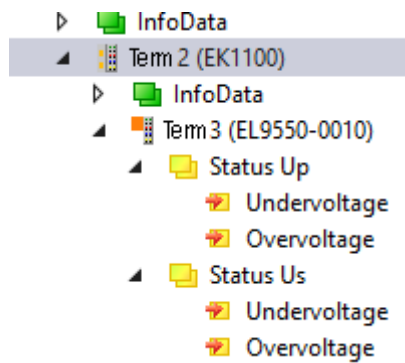

Fig. 44: EL9550-0010 in TwinCAT tree

2.13.2 EL9540, EL9550 - application example

⚠ WARNING

Risk of injury through electric shock and damage to the device!

Bring the Bus Terminals system into a safe, de-energized state before starting mounting, disassembly or wiring of the Bus Terminals!

The example shows

- a EL9550 Surge Filter Terminal for supplying
 - the Bus Coupler (U_L : E-Bus supply)
 - the field voltage (U_{S1} : power contacts, potential group 1)
- a EL9540 Surge Filter Terminal in conjunction with the EL9190 power feed terminal for power supply
 - the field voltage (U_{S2} : power contacts, potential group 2)

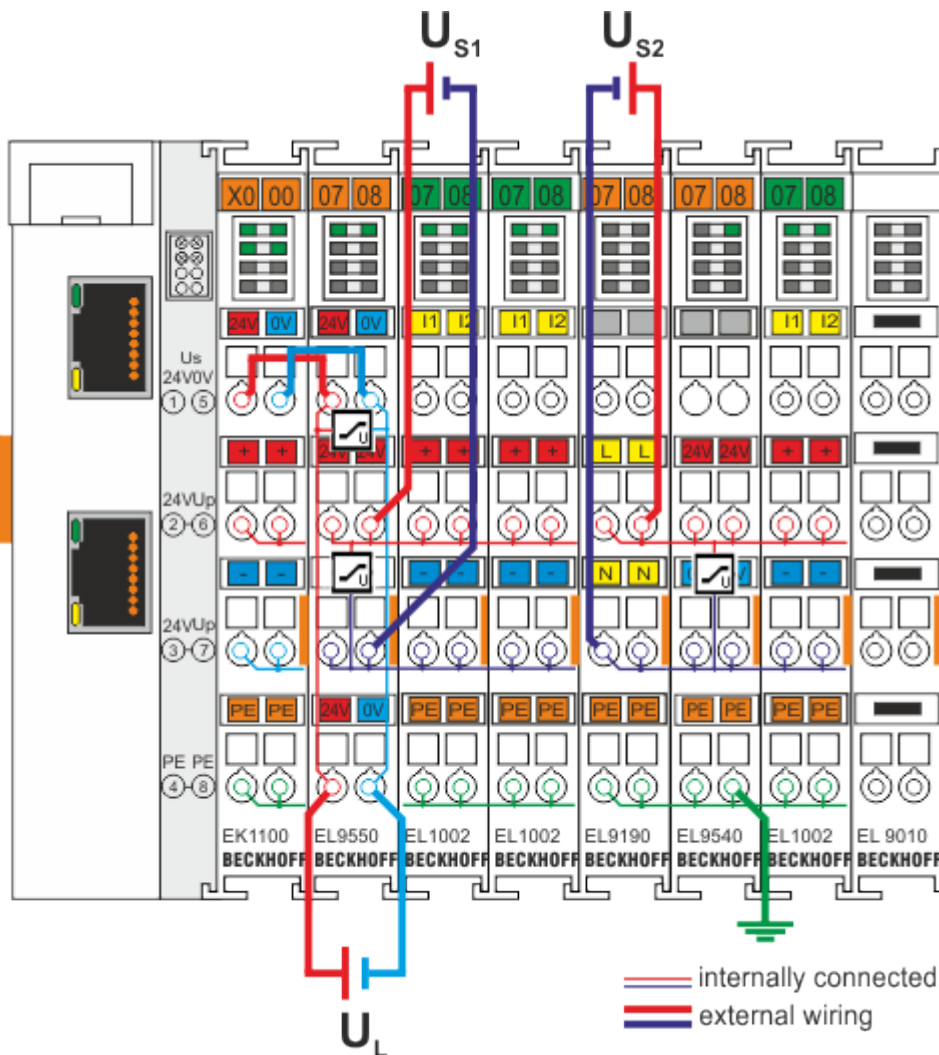

Fig. 45: Application example EL9540, EL9550

2.13.3 EL9540-0010, EL9550 - application example

⚠ WARNING

Risk of injury through electric shock and damage to the device!

Bring the Bus Terminals system into a safe, de-energized state before starting mounting, disassembly or wiring of the Bus Terminals!

The example shows

- a EL9550 Surge Filter Terminal for power supply
 - the Bus Coupler (U_L : E-Bus power supply)
 - the field voltage for the digital terminals (U_{S1} : power contacts, potential group 1)
- a EL9540-0010 Surge Filter Terminal for power supply
 - the field voltage for the analog terminals (U_{S2} : power contacts, potential group 2)

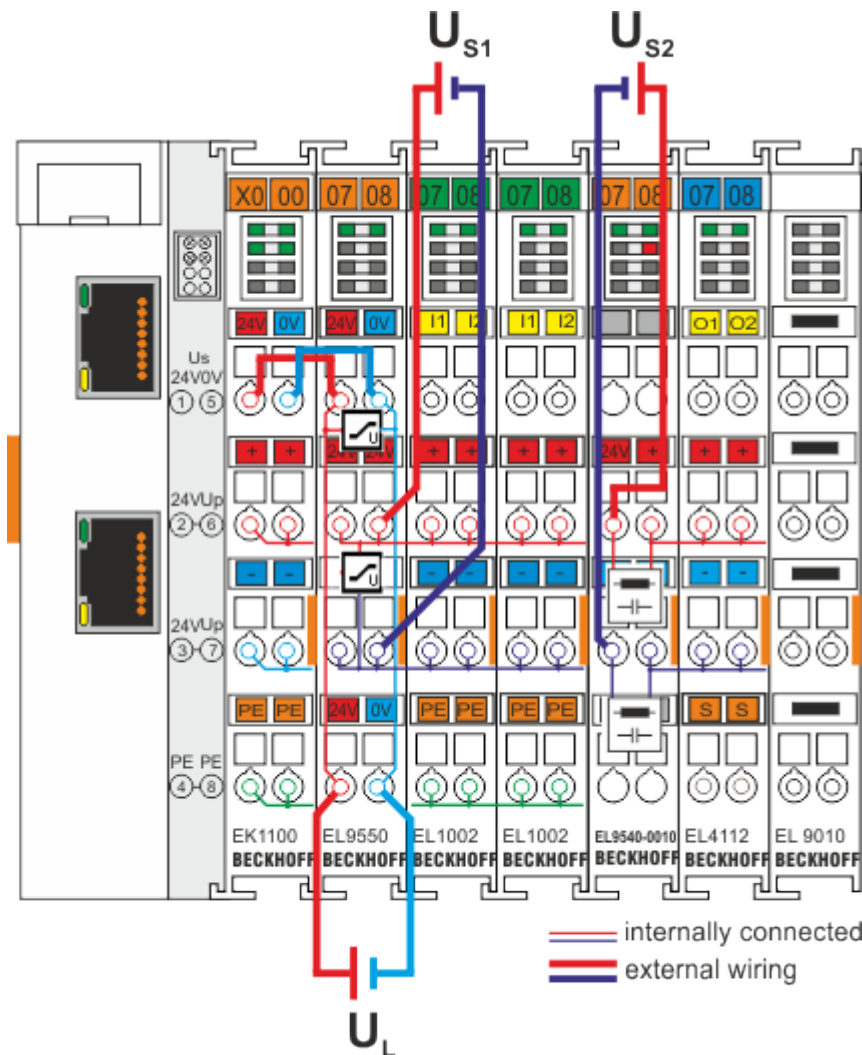

Fig. 46: EL9540-0010, EL9550 - application example

2.14 EL9570

2.14.1 EL9570 - Introduction and Technical Data

Buffer capacitor terminal

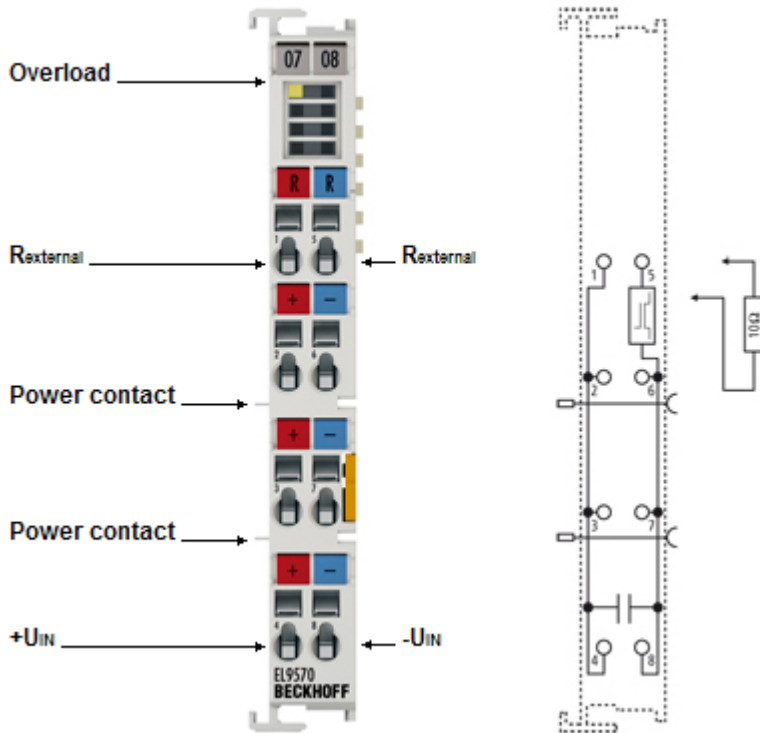

Fig. 47: EL9570

The EL9570 Bus Terminal contains high-performance capacitors for stabilizing supply voltages.

The EL9570 can be used e.g. in conjunction with the EL7041 stepper motor terminal, the EL7342 DC motor terminal or the EL7201 servomotor terminal.

Low internal resistance and high-pulsed current capability enable good buffering in parallel with a power supply unit. Return currents are stored, particularly in the context of drive applications, thereby preventing overvoltages. If the regenerative energy exceeds the capacity of the capacitors, energy can be dissipated via an external ballast resistor.

Technical data

Technical data	EL9570
Technology	buffer capacitor
Nominal voltage	50 V
Capacity	500 µF
Ripple current	10 A in continuous operation
Internal resistance	< 10 mΩ
Surge voltage protection	> 56 V
Recommended ballast resistor	10 Ω, 10 W typ.
Overvoltage control range	±2 V
Ballast resistor clock rate	load-dependent, 2-point control
Electrical isolation	1500 V
Diagnostics	-
Message to E-Bus	-
PE contact	no
Shield connection	-
Current consumption from E-Bus	-
Bit width in the process image	0
Electrical connection to mounting rail	-
Electrical isolation	-
Renewed infeed	-
Connection facility to additional power contact	-
Side by side mounting on EtherCAT Terminals with power contact	yes, left side without PE
Side by side mounting on EtherCAT Terminals without power contact	yes
Configuration	no address or configuration settings
Weight	approx.. 90 g
Permissible ambient temperature range (during operation)	0°C ... +55°C
Permissible ambient temperature range (during storage)	-25°C ... +85°C
Permissible relative humidity	95%, no condensation
Dimensions (W x H x D)	approx. 15 mm x 100 mm x 70 mm (width aligned: 12 mm)
<u>Mounting</u> [▶ 93]	on 35 mm mounting rail conforms to EN 60715
Vibration / shock resistance	conforms to EN 60068-2-6 / EN 60068-2-27
EMC resistance burst / ESD	conforms to EN 61000-6-2 / EN 61000-6-4
Protection class	IP20
Installation position	variable, see chapter "Mounting of Passive Terminals [▶ 99]"
Approvals / markings*	CE, UKCA, EAC, ATEX [▶ 86], IECEx [▶ 88]

*) Real applicable approvals/markings see type plate on the side (product marking).

Ex markings

Standard	Marking
ATEX	II 3 G Ex nA IIC T4 Gc
IECEX	Ex nA IIC T4 Gc

LEDs and connection EL9570

LED	Color	Meaning	
Overload	green	off	No error
		on	Overload, energy will be absorbed in the connected ballast resistor

Terminal point		Description
Indication	No.	
R_{external}	1	Connection for ballast resistor
$+U_{\text{IN}}$	2	Positive input for buffer voltage (internally connected with terminal point 3 and 4)
$+U_{\text{IN}}$	3	Positive input for buffer voltage (internally connected with terminal point 2 and 4)
$+U_{\text{IN}}$	4	Positive input for buffer voltage (internally connected with terminal point 2 and 3)
R_{external}	5	Connection for ballast resistor
$-U_{\text{IN}}$	6	Negative input for buffer voltage (internally connected with terminal point 7 and 8)
$-U_{\text{IN}}$	7	Negative input for buffer voltage (internally connected with terminal point 6 and 8)
$-U_{\text{IN}}$	8	Negative input for buffer voltage (internally connected with terminal point 6 and 7)

2.14.2 Application example

⚠ WARNING

Risk of electric shock and damage of device!

Bring the bus terminal system into a safe, powered down state before starting installation, disassembly or wiring of the Bus Terminals!

Application example

- The capacitor within the EL9570 compensates peaks on the power supply of the stepper motor / DC motor.
- As soon as the supply voltages increases 55 V, the EL9570 switches on the brake resistor $R_{EXTERNAL}$, to burn the back loaded braking energy of the stepper motor / DC motor connected to the EL7041.

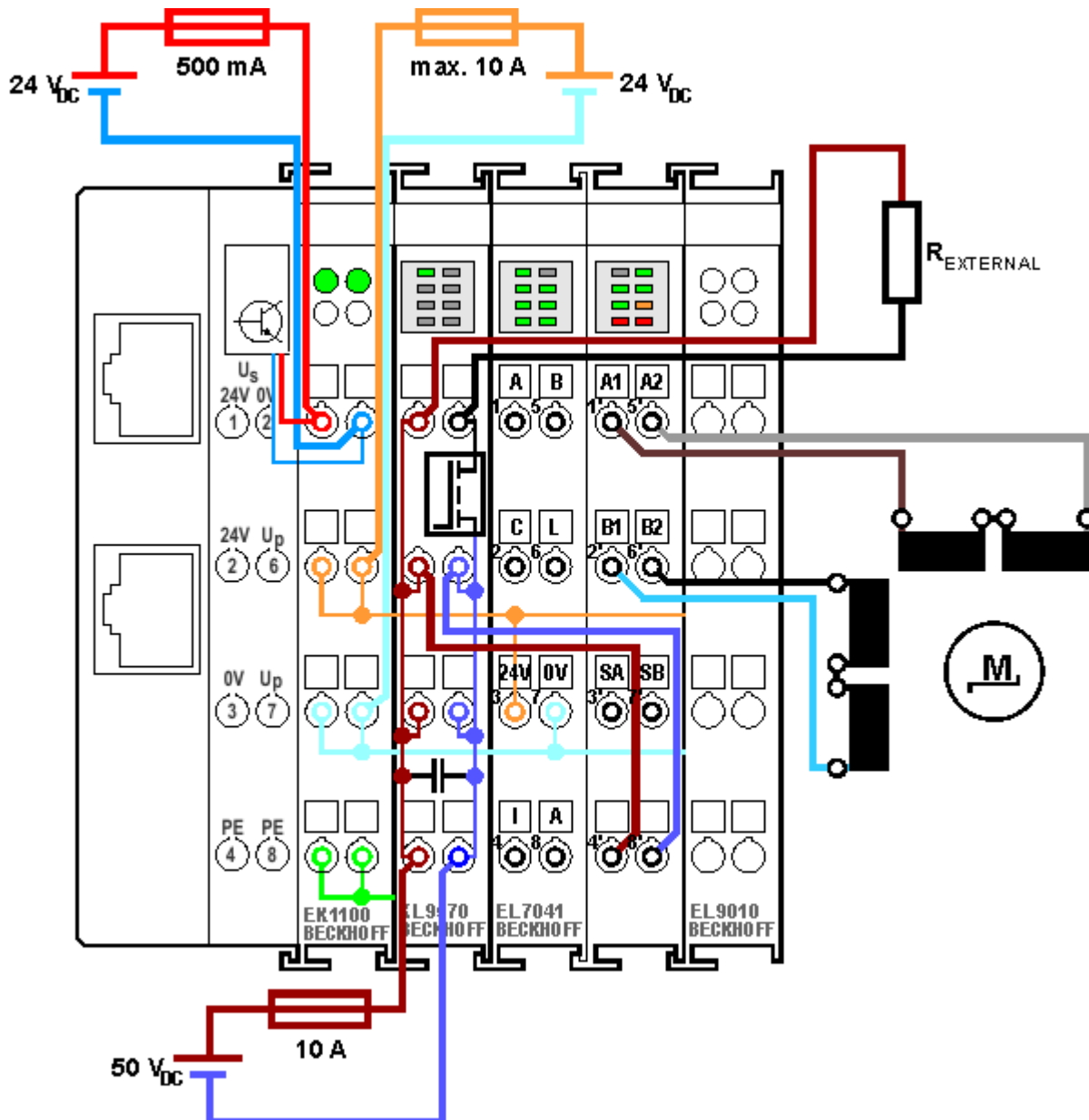

Fig. 48: Application example EL9570

i More motors

A capacitor EL9570 terminal is able to condition the power supply of several motors.

NOTICE**Dimensioning of the brake resistor**

The brake resistor R_{EXTERNAL} (typically 10Ω) should be dimensioned in that way, that it can stand the expected heat without damage!

3 Basics communication

3.1 EtherCAT basics

Please refer to the [EtherCAT System Documentation](#) for the EtherCAT fieldbus basics.

3.2 EtherCAT cabling – wire-bound

The cable length between two EtherCAT devices must not exceed 100 m. This results from the FastEthernet technology, which, above all for reasons of signal attenuation over the length of the cable, allows a maximum link length of 5 + 90 + 5 m if cables with appropriate properties are used. See also the [Design recommendations for the infrastructure for EtherCAT/Ethernet](#).

Cables and connectors

For connecting EtherCAT devices only Ethernet connections (cables + plugs) that meet the requirements of at least category 5 (Cat5) according to EN 50173 or ISO/IEC 11801 should be used. EtherCAT uses 4 wires for signal transfer.

EtherCAT uses RJ45 plug connectors, for example. The pin assignment is compatible with the Ethernet standard (ISO/IEC 8802-3).

Pin	Color of conductor	Signal	Description
1	yellow	TD +	Transmission Data +
2	orange	TD -	Transmission Data -
3	white	RD +	Receiver Data +
6	blue	RD -	Receiver Data -

Due to automatic cable detection (auto-crossing) symmetric (1:1) or cross-over cables can be used between EtherCAT devices from Beckhoff.

● Recommended cables

- i** It is recommended to use the appropriate Beckhoff components e.g.
- cable sets ZK1090-9191-xxxx respectively
 - RJ45 connector, field assembly ZS1090-0005
 - EtherCAT cable, field assembly ZB9010, ZB9020

Suitable cables for the connection of EtherCAT devices can be found on the [Beckhoff website!](#)

E-Bus supply

A bus coupler can supply the EL terminals added to it with the E-bus system voltage of 5 V; a coupler is thereby loadable up to 2 A as a rule (see details in respective device documentation). Information on how much current each EL terminal requires from the E-bus supply is available online and in the catalogue. If the added terminals require more current than the coupler can supply, then power feed terminals (e.g. [EL9410](#)) must be inserted at appropriate places in the terminal strand.

The pre-calculated theoretical maximum E-Bus current is displayed in the TwinCAT System Manager. A shortfall is marked by a negative total amount and an exclamation mark; a power feed terminal is to be placed before such a position.

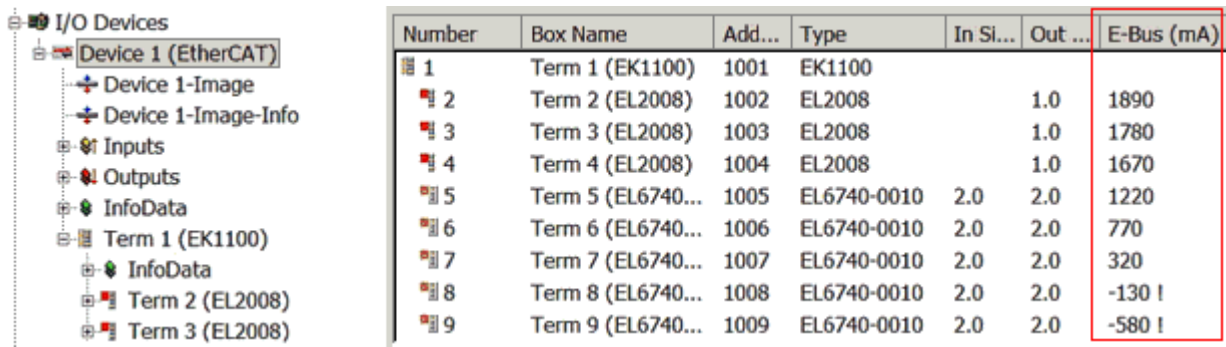

Fig. 49: System manager current calculation

NOTICE

Malfunction possible!
 The same ground potential must be used for the E-Bus supply of all EtherCAT terminals in a terminal block!

3.3 EtherCAT State Machine

The state of the EtherCAT slave is controlled via the EtherCAT State Machine (ESM). Depending upon the state, different functions are accessible or executable in the EtherCAT slave. Specific commands must be sent by the EtherCAT master to the device in each state, particularly during the bootup of the slave.

A distinction is made between the following states:

- Init
- Pre-Operational
- Safe-Operational and
- Operational
- Boot

The regular state of each EtherCAT slave after bootup is the OP state.

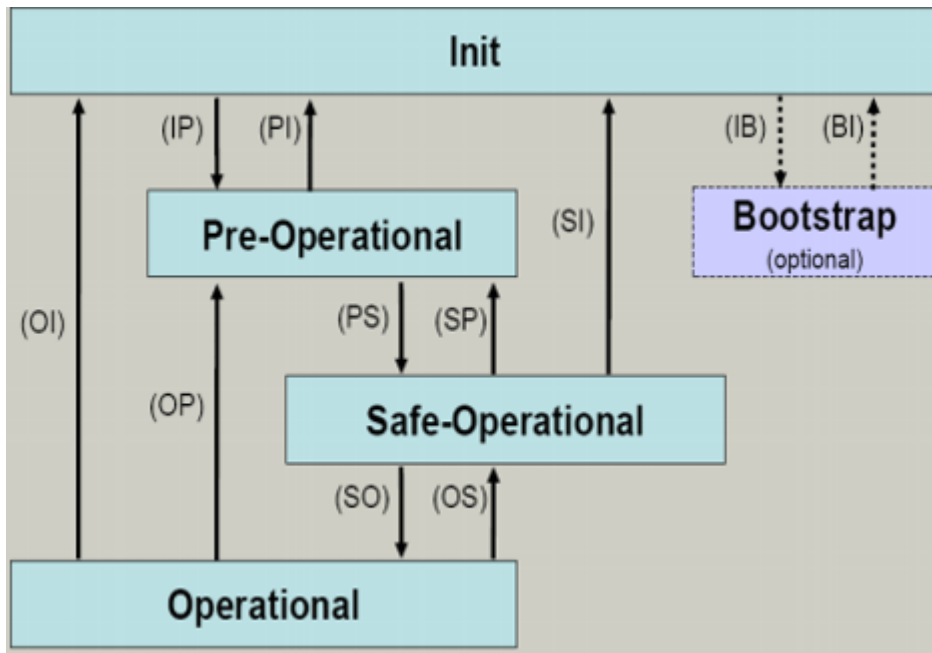

Fig. 50: States of the EtherCAT State Machine

Init

After switch-on the EtherCAT slave in the *Init* state. No mailbox or process data communication is possible. The EtherCAT master initializes sync manager channels 0 and 1 for mailbox communication.

Pre-Operational (Pre-Op)

During the transition between *Init* and *Pre-Op* the EtherCAT slave checks whether the mailbox was initialized correctly.

In *Pre-Op* state mailbox communication is possible, but not process data communication. The EtherCAT master initializes the sync manager channels for process data (from sync manager channel 2), the FMMU channels and, if the slave supports configurable mapping, PDO mapping or the sync manager PDO assignment. In this state the settings for the process data transfer and perhaps terminal-specific parameters that may differ from the default settings are also transferred.

Safe-Operational (Safe-Op)

During transition between *Pre-Op* and *Safe-Op* the EtherCAT slave checks whether the sync manager channels for process data communication and, if required, the distributed clocks settings are correct. Before it acknowledges the change of state, the EtherCAT slave copies current input data into the associated DP-RAM areas of the EtherCAT slave controller (ECSC).

In *Safe-Op* state mailbox and process data communication is possible, although the slave keeps its outputs in a safe state, while the input data are updated cyclically.

**Outputs in SAFEOP state**

The default set watchdog monitoring sets the outputs of the module in a safe state - depending on the settings in SAFEOP and OP - e.g. in OFF state. If this is prevented by deactivation of the watchdog monitoring in the module, the outputs can be switched or set also in the SAFEOP state.

Operational (Op)

Before the EtherCAT master switches the EtherCAT slave from *Safe-Op* to *Op* it must transfer valid output data.

In the *Op* state the slave copies the output data of the masters to its outputs. Process data and mailbox communication is possible.

Boot

In the *Boot* state the slave firmware can be updated. The *Boot* state can only be reached via the *Init* state.

In the *Boot* state mailbox communication via the *file access over EtherCAT* (FoE) protocol is possible, but no other mailbox communication and no process data communication.

3.4 CoE Interface

General description

The CoE interface (CAN application protocol over EtherCAT) is used for parameter management of EtherCAT devices. EtherCAT slaves or the EtherCAT master manage fixed (read only) or variable parameters which they require for operation, diagnostics or commissioning.

CoE parameters are arranged in a table hierarchy. In principle, the user has read access via the fieldbus. The EtherCAT master (TwinCAT System Manager) can access the local CoE lists of the slaves via EtherCAT in read or write mode, depending on the attributes.

Different CoE parameter types are possible, including string (text), integer numbers, Boolean values or larger byte fields. They can be used to describe a wide range of features. Examples of such parameters include manufacturer ID, serial number, process data settings, device name, calibration values for analog measurement or passwords.

The order is specified in two levels via hexadecimal numbering: (main)index, followed by subindex. The value ranges are

- Index: 0x0000 ...0xFFFF (0...65535_{dec})
- SubIndex: 0x00...0xFF (0...255_{dec})

A parameter localized in this way is normally written as 0x8010:07, with preceding “0x” to identify the hexadecimal numerical range and a colon between index and subindex.

The relevant ranges for EtherCAT fieldbus users are:

- 0x1000: This is where fixed identity information for the device is stored, including name, manufacturer, serial number etc., plus information about the current and available process data configurations.
- 0x8000: This is where the operational and functional parameters for all channels are stored, such as filter settings or output frequency.

Other important ranges are:

- 0x4000: here are the channel parameters for some EtherCAT devices. Historically, this was the first parameter area before the 0x8000 area was introduced. EtherCAT devices that were previously equipped with parameters in 0x4000 and changed to 0x8000 support both ranges for compatibility reasons and mirror internally.
- 0x6000: Input PDOs (“input” from the perspective of the EtherCAT master)
- 0x7000: Output PDOs (“output” from the perspective of the EtherCAT master)

Availability

i Not every EtherCAT device must have a CoE list. Simple I/O modules without dedicated processor usually have no variable parameters and therefore no CoE list.

If a device has a CoE list, it is shown in the TwinCAT System Manager as a separate tab with a listing of the elements:

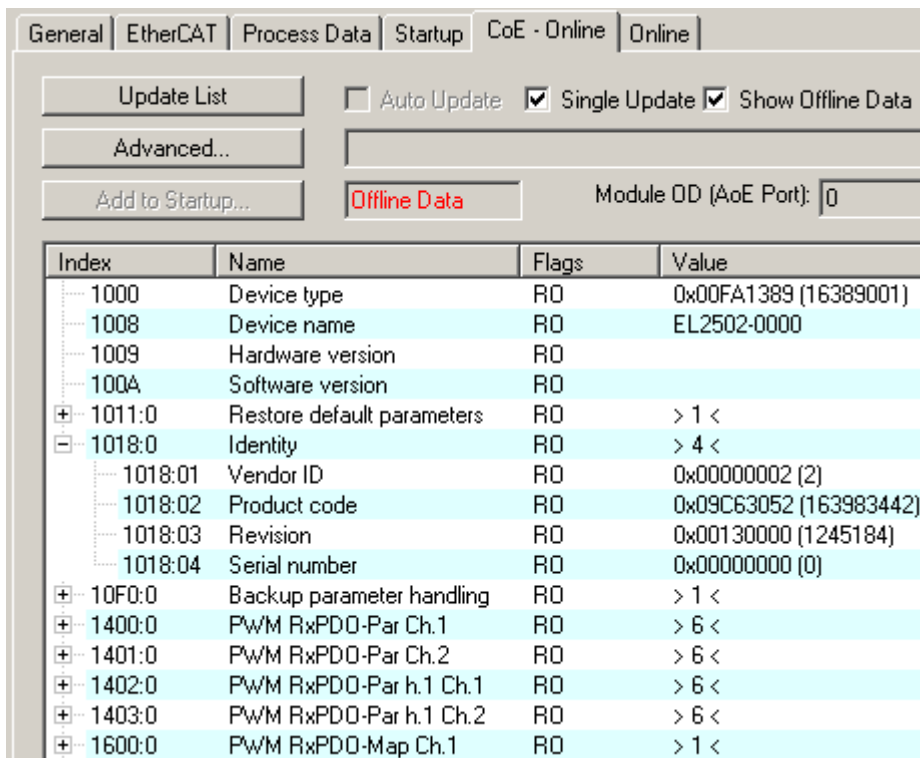

Fig. 51: “CoE Online” tab

The figure above shows the CoE objects available in device “EL2502”, ranging from 0x1000 to 0x1600. The subindices for 0x1018 are expanded.

NOTICE**Changes in the CoE directory (CAN over EtherCAT), program access**

When using/manipulating the CoE parameters observe the general CoE notes in chapter "[CoE interface](#)" of the EtherCAT system documentation:

- Keep a startup list if components have to be replaced,
- Distinction between online/offline dictionary,
- Existence of current XML description (download from the [Beckhoff website](#)),
- "CoE-Reload" for resetting the changes
- Program access during operation via PLC (see [TwinCAT3 | PLC Library: Tc2 EtherCAT](#) and [Example program R/W CoE](#))

Data management and function "NoCoeStorage"

Some parameters, particularly the setting parameters of the slave, are configurable and writeable. This can be done in write or read mode

- via the System Manager (Fig. "CoE Online" tab) by clicking
This is useful for commissioning of the system/slaves. Click on the row of the index to be parameterized and enter a value in the "SetValue" dialog.
- from the control system/PLC via ADS, e.g. through blocks from the TcEtherCAT.lib library
This is recommended for modifications while the system is running or if no System Manager or operating staff are available.

● Data management

i If slave CoE parameters are modified online, Beckhoff devices store any changes in a fail-safe manner in the EEPROM, i.e. the modified CoE parameters are still available after a restart. The situation may be different with other manufacturers.

An EEPROM is subject to a limited lifetime with respect to write operations. From typically 100,000 write operations onwards it can no longer be guaranteed that new (changed) data are reliably saved or are still readable. This is irrelevant for normal commissioning. However, if CoE parameters are continuously changed via ADS at machine runtime, it is quite possible for the lifetime limit to be reached. Support for the NoCoeStorage function, which suppresses the saving of changed CoE values, depends on the firmware version.

Please refer to the technical data in this documentation as to whether this applies to the respective device.

- If the function is supported: the function is activated by entering the code word 0x12345678 once in CoE 0xF008 and remains active as long as the code word is not changed. After switching the device on it is then inactive. Changed CoE values are not saved in the EEPROM and can thus be changed any number of times.
- Function is not supported: continuous changing of CoE values is not permissible in view of the lifetime limit.

● Startup list

i Changes in the local CoE list of the terminal are lost if the terminal is replaced. If a terminal is replaced with a new Beckhoff terminal, it will have the default settings. It is therefore advisable to link all changes in the CoE list of an EtherCAT slave with the Startup list of the slave, which is processed whenever the EtherCAT fieldbus is started. In this way a replacement EtherCAT slave can automatically be parameterized with the specifications of the user.

If EtherCAT slaves are used which are unable to store local CoE values permanently, the Startup list must be used.

Recommended approach for manual modification of CoE parameters

- Make the required change in the System Manager
The values are stored locally in the EtherCAT slave

- If the value is to be stored permanently, enter it in the Startup list.
The order of the Startup entries is usually irrelevant.

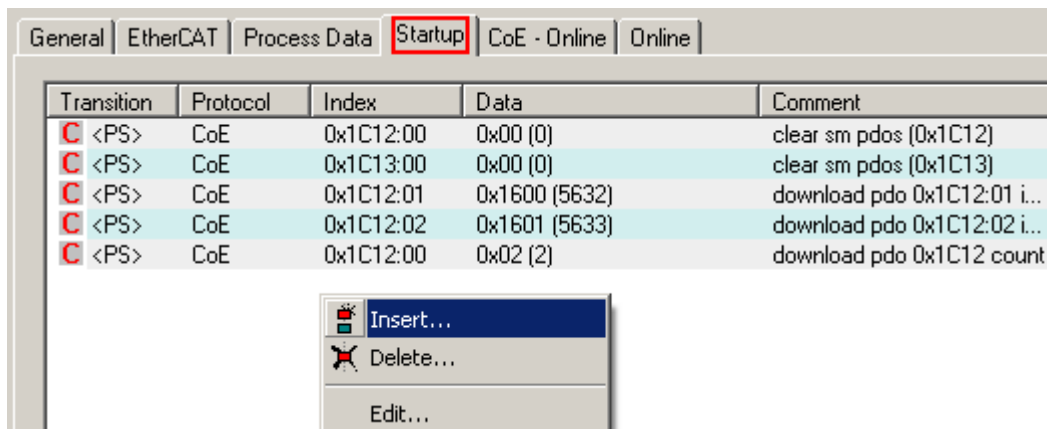

Fig. 52: Startup list in the TwinCAT System Manager

The Startup list may already contain values that were configured by the System Manager based on the ESI specifications. Additional application-specific entries can be created.

Online/offline list

While working with the TwinCAT System Manager, a distinction has to be made whether the EtherCAT device is “available”, i.e. switched on and linked via EtherCAT and therefore **online**, or whether a configuration is created **offline** without connected slaves.

In both cases a CoE list as shown in Fig. “CoE online tab” is displayed. The connectivity is shown as offline/online.

- If the slave is offline
 - The offline list from the ESI file is displayed. In this case modifications are not meaningful or possible.
 - The configured status is shown under Identity.
 - No firmware or hardware version is displayed, since these are features of the physical device.
 - **Offline** is shown in red.

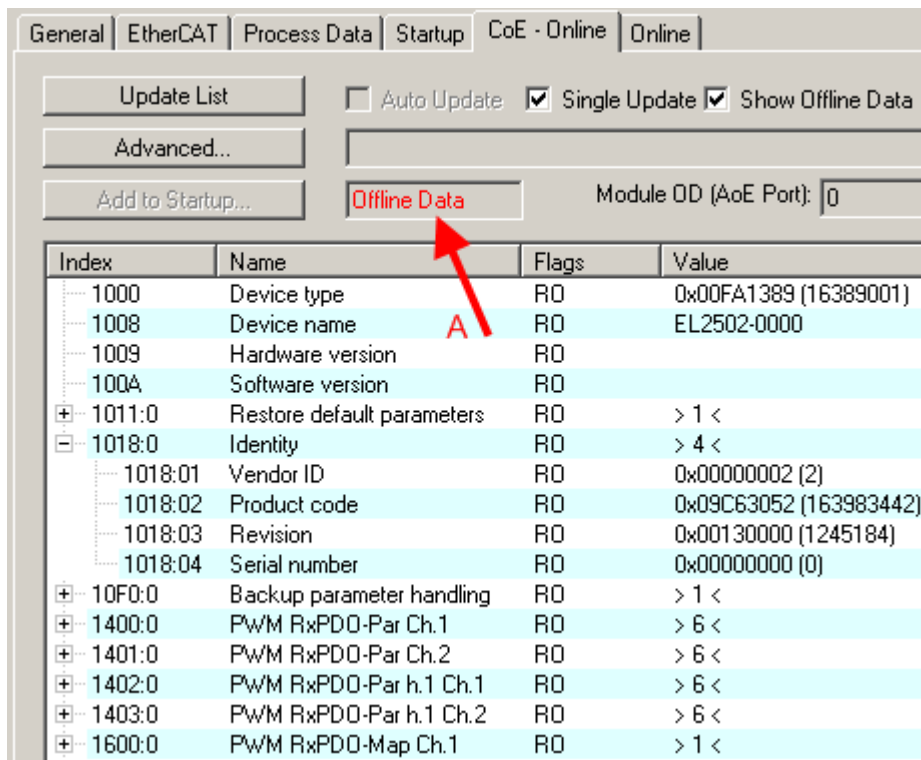

Fig. 53: Offline list

- If the slave is online
 - The actual current slave list is read. This may take several seconds, depending on the size and cycle time.
 - The actual identity is displayed
 - The firmware and hardware version of the equipment according to the electronic information is displayed
 - **Online** is shown in green.

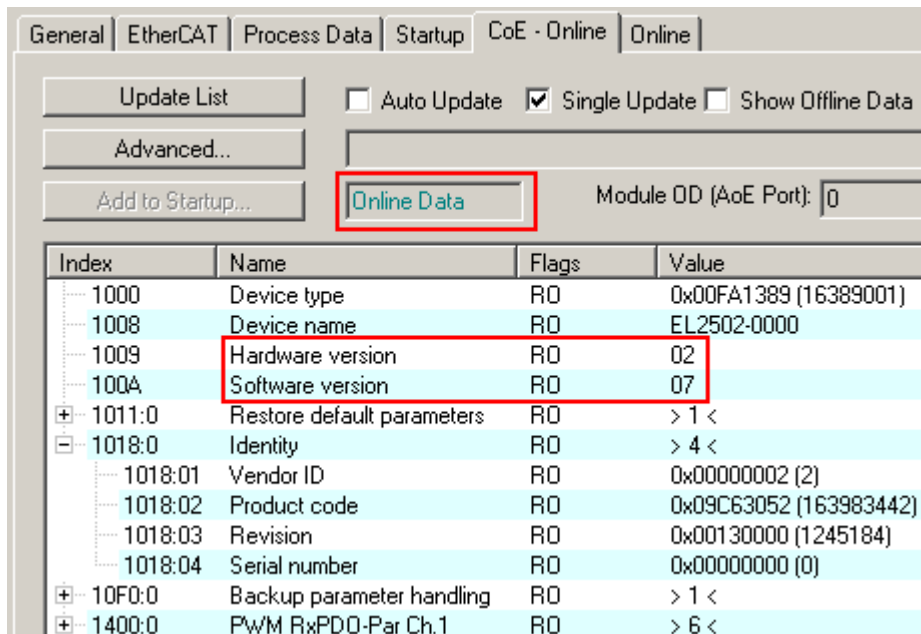

Fig. 54: Online list

Channel-based order

The CoE list is available in EtherCAT devices that usually feature several functionally equivalent channels. For example, a 4-channel analog 0...10 V input terminal also has four logical channels and therefore four identical sets of parameter data for the channels. In order to avoid having to list each channel in the documentation, the placeholder “n” tends to be used for the individual channel numbers.

In the CoE system 16 indices, each with 255 subindices, are generally sufficient for representing all channel parameters. The channel-based order is therefore arranged in $16_{\text{dec}}/10_{\text{hex}}$ steps. The parameter range 0x8000 exemplifies this:

- Channel 0: parameter range 0x8000:00 ... 0x800F:255
- Channel 1: parameter range 0x8010:00 ... 0x801F:255
- Channel 2: parameter range 0x8020:00 ... 0x802F:255
- ...

This is generally written as 0x80n0.

Detailed information on the CoE interface can be found in the [EtherCAT system documentation](#) on the Beckhoff website.

4 Mounting and wiring

4.1 Instructions for ESD protection

NOTICE

Destruction of the devices by electrostatic discharge possible!

The devices contain components at risk from electrostatic discharge caused by improper handling.

- Please ensure you are electrostatically discharged and avoid touching the contacts of the device directly.
- Avoid contact with highly insulating materials (synthetic fibers, plastic film etc.).
- Surroundings (working place, packaging and personnel) should be grounded probably, when handling with the devices.
- Each assembly must be terminated at the right hand end with an [EL9011](#) or [EL9012](#) bus end cap, to ensure the protection class and ESD protection.

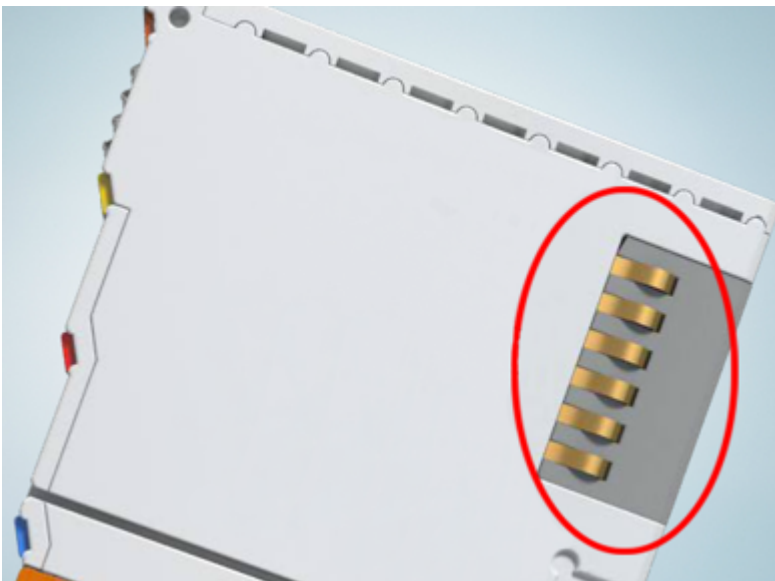

Fig. 55: Spring contacts of the Beckhoff I/O components

4.2 Explosion protection

4.2.1 ATEX - Special conditions (standard temperature range)

⚠ WARNING

Observe the special conditions for the intended use of Beckhoff fieldbus components with standard temperature range in potentially explosive areas (directive 2014/34/EU)!

- The certified components are to be installed in a suitable housing that guarantees a protection class of at least IP54 in accordance with EN 60079-15! The environmental conditions during use are thereby to be taken into account!
- For dust (only the fieldbus components of certificate no. KEMA 10ATEX0075 X Issue 9): The equipment shall be installed in a suitable enclosure providing a degree of protection of IP54 according to EN 60079-31 for group IIIA or IIIB and IP6X for group IIIC, taking into account the environmental conditions under which the equipment is used!
- If the temperatures during rated operation are higher than 70°C at the feed-in points of cables, lines or pipes, or higher than 80°C at the wire branching points, then cables must be selected whose temperature data correspond to the actual measured temperature values!
- Observe the permissible ambient temperature range of 0 to 55°C for the use of Beckhoff fieldbus components standard temperature range in potentially explosive areas!
- Measures must be taken to protect against the rated operating voltage being exceeded by more than 40% due to short-term interference voltages!
- The individual terminals may only be unplugged or removed from the Bus Terminal system if the supply voltage has been switched off or if a non-explosive atmosphere is ensured!
- The connections of the certified components may only be connected or disconnected if the supply voltage has been switched off or if a non-explosive atmosphere is ensured!
- The fuses of the KL92xx/EL92xx power feed terminals may only be exchanged if the supply voltage has been switched off or if a non-explosive atmosphere is ensured!
- Address selectors and ID switches may only be adjusted if the supply voltage has been switched off or if a non-explosive atmosphere is ensured!

Standards

The fundamental health and safety requirements are fulfilled by compliance with the following standards:

- EN 60079-0:2012+A11:2013
- EN 60079-15:2010
- EN 60079-31:2013 (only for certificate no. KEMA 10ATEX0075 X Issue 9)

Marking

The Beckhoff fieldbus components with standard temperature range certified according to the ATEX directive for potentially explosive areas bear one of the following markings:



II 3G KEMA 10ATEX0075 X Ex nA IIC T4 Gc Ta: 0 ... +55°C
 II 3D KEMA 10ATEX0075 X Ex tc IIIC T135°C Dc Ta: 0 ... +55°C
 (only for fieldbus components of certificate no. KEMA 10ATEX0075 X Issue 9)

or



II 3G KEMA 10ATEX0075 X Ex nA nC IIC T4 Gc Ta: 0 ... +55°C
 II 3D KEMA 10ATEX0075 X Ex tc IIIC T135°C Dc Ta: 0 ... +55°C
 (only for fieldbus components of certificate no. KEMA 10ATEX0075 X Issue 9)

4.2.2 ATEX - Special conditions (extended temperature range)

⚠ WARNING

Observe the special conditions for the intended use of Beckhoff fieldbus components with extended temperature range (ET) in potentially explosive areas (directive 2014/34/EU)!

- The certified components are to be installed in a suitable housing that guarantees a protection class of at least IP54 in accordance with EN 60079-15! The environmental conditions during use are thereby to be taken into account!
- For dust (only the fieldbus components of certificate no. KEMA 10ATEX0075 X Issue 9): The equipment shall be installed in a suitable enclosure providing a degree of protection of IP54 according to EN 60079-31 for group IIIA or IIIB and IP6X for group IIIC, taking into account the environmental conditions under which the equipment is used!
- If the temperatures during rated operation are higher than 70°C at the feed-in points of cables, lines or pipes, or higher than 80°C at the wire branching points, then cables must be selected whose temperature data correspond to the actual measured temperature values!
- Observe the permissible ambient temperature range of -25 to 60°C for the use of Beckhoff fieldbus components with extended temperature range (ET) in potentially explosive areas!
- Measures must be taken to protect against the rated operating voltage being exceeded by more than 40% due to short-term interference voltages!
- The individual terminals may only be unplugged or removed from the Bus Terminal system if the supply voltage has been switched off or if a non-explosive atmosphere is ensured!
- The connections of the certified components may only be connected or disconnected if the supply voltage has been switched off or if a non-explosive atmosphere is ensured!
- The fuses of the KL92xx/EL92xx power feed terminals may only be exchanged if the supply voltage has been switched off or if a non-explosive atmosphere is ensured!
- Address selectors and ID switches may only be adjusted if the supply voltage has been switched off or if a non-explosive atmosphere is ensured!

Standards

The fundamental health and safety requirements are fulfilled by compliance with the following standards:

- EN 60079-0:2012+A11:2013
- EN 60079-15:2010
- EN 60079-31:2013 (only for certificate no. KEMA 10ATEX0075 X Issue 9)

Marking

The Beckhoff fieldbus components with extended temperature range (ET) certified according to the ATEX directive for potentially explosive areas bear the following marking:



II 3G KEMA 10ATEX0075 X Ex nA IIC T4 Gc Ta: -25 ... +60°C
 II 3D KEMA 10ATEX0075 X Ex tc IIIC T135°C Dc Ta: -25 ... +60°C
 (only for fieldbus components of certificate no. KEMA 10ATEX0075 X Issue 9)

or



II 3G KEMA 10ATEX0075 X Ex nA nC IIC T4 Gc Ta: -25 ... +60°C
 II 3D KEMA 10ATEX0075 X Ex tc IIIC T135°C Dc Ta: -25 ... +60°C
 (only for fieldbus components of certificate no. KEMA 10ATEX0075 X Issue 9)

4.2.3 IECEx - Special conditions

WARNING

Observe the special conditions for the intended use of Beckhoff fieldbus components in potentially explosive areas!

- For gas: The equipment shall be installed in a suitable enclosure providing a degree of protection of IP54 according to IEC 60079-15, taking into account the environmental conditions under which the equipment is used!
- For dust (only the fieldbus components of certificate no. IECEx DEK 16.0078X Issue 3): The equipment shall be installed in a suitable enclosure providing a degree of protection of IP54 according to EN 60079-31 for group IIIA or IIIB and IP6X for group IIIC, taking into account the environmental conditions under which the equipment is used!
- The equipment shall only be used in an area of at least pollution degree 2, as defined in IEC 60664-1!
- Provisions shall be made to prevent the rated voltage from being exceeded by transient disturbances of more than 119 V!
- If the temperatures during rated operation are higher than 70°C at the feed-in points of cables, lines or pipes, or higher than 80°C at the wire branching points, then cables must be selected whose temperature data correspond to the actual measured temperature values!
- Observe the permissible ambient temperature range for the use of Beckhoff fieldbus components in potentially explosive areas!
- The individual terminals may only be unplugged or removed from the Bus Terminal system if the supply voltage has been switched off or if a non-explosive atmosphere is ensured!
- The connections of the certified components may only be connected or disconnected if the supply voltage has been switched off or if a non-explosive atmosphere is ensured!
- Address selectors and ID switches may only be adjusted if the supply voltage has been switched off or if a non-explosive atmosphere is ensured!
- The front hatch of certified units may only be opened if the supply voltage has been switched off or a non-explosive atmosphere is ensured!

Standards

The fundamental health and safety requirements are fulfilled by compliance with the following standards:

- EN 60079-0:2011
- EN 60079-15:2010
- EN 60079-31:2013 (only for certificate no. IECEx DEK 16.0078X Issue 3)

Marking

Beckhoff fieldbus components that are certified in accordance with IECEx for use in areas subject to an explosion hazard bear the following markings:

Marking for fieldbus components of certificate no. IECEx DEK 16.0078X Issue 3:

IECEx DEK 16.0078 X
Ex nA IIC T4 Gc
Ex tc IIIC T135°C Dc

Marking for fieldbus components of certificates with later issues:

IECEx DEK 16.0078 X
Ex nA IIC T4 Gc

4.2.4 Continulative documentation for ATEX and IECEx

NOTICE



Continulative documentation about explosion protection according to ATEX and IECEx

Pay also attention to the continuative documentation

Ex. Protection for Terminal Systems

Notes on the use of the Beckhoff terminal systems in hazardous areas according to ATEX and IECEx,

that is available for [download](#) within the download area of your product on the Beckhoff homepage www.beckhoff.com!

4.2.5 cFMus - Special conditions

WARNING

Observe the special conditions for the intended use of Beckhoff fieldbus components in potentially explosive areas!

- The equipment shall be installed within an enclosure that provides a minimum ingress protection of IP54 in accordance with ANSI/UL 60079-0 (US) or CSA C22.2 No. 60079-0 (Canada).
- The equipment shall only be used in an area of at least pollution degree 2, as defined in IEC 60664-1.
- Transient protection shall be provided that is set at a level not exceeding 140% of the peak rated voltage value at the supply terminals to the equipment.
- The circuits shall be limited to overvoltage Category II as defined in IEC 60664-1.
- The Fieldbus Components may only be removed or inserted when the system supply and the field supply are switched off, or when the location is known to be non-hazardous.
- The Fieldbus Components may only be disconnected or connected when the system supply is switched off, or when the location is known to be non-hazardous.

Standards

The fundamental health and safety requirements are fulfilled by compliance with the following standards:

M20US0111X (US):

- FM Class 3600:2018
- FM Class 3611:2018
- FM Class 3810:2018
- ANSI/UL 121201:2019
- ANSI/ISA 61010-1:2012
- ANSI/UL 60079-0:2020
- ANSI/UL 60079-7:2017

FM20CA0053X (Canada):

- CAN/CSA C22.2 No. 213-17:2017
- CSA C22.2 No. 60079-0:2019
- CAN/CSA C22.2 No. 60079-7:2016
- CAN/CSA C22.2 No.61010-1:2012

Marking

Beckhoff fieldbus components that are certified in accordance with cFMus for use in areas subject to an explosion hazard bear the following markings:

FM20US0111X (US): **Class I, Division 2, Groups A, B, C, D**
 Class I, Zone 2, AEx ec IIC T4 Gc

FM20CA0053X (Canada): **Class I, Division 2, Groups A, B, C, D**
 Ex ec T4 Gc

4.2.6 Continulative documentation for cFMus

NOTICE



Continulative documentation about explosion protection according to cFMus







Pay also attention to the continuative documentation

Control Drawing I/O, CX, CPX

Connection diagrams and Ex markings,

that is available for download within the download area of your product on the Beckhoff homepage www.beckhoff.com!

4.3 UL notice

⚠ CAUTION	
	<p>Application</p> <p>Beckhoff EtherCAT modules are intended for use with Beckhoff's UL Listed EtherCAT System only.</p>
⚠ CAUTION	
	<p>Examination</p> <p>For cULus examination, the Beckhoff I/O System has only been investigated for risk of fire and electrical shock (in accordance with UL508 and CSA C22.2 No. 142).</p>
⚠ CAUTION	
	<p>For devices with Ethernet connectors</p> <p>Not for connection to telecommunication circuits.</p>
⚠ CAUTION	
	<p>Usage of suitable copper cables</p> <p>In order to comply with UL approval, use copper cables that are designed for operating temperatures $\geq 90^{\circ}\text{C}$.</p>
⚠ CAUTION	
	<p>External overcurrent protection</p> <p>External overcurrent protection is required for each input exceeding levels of 30Vrms, 42.4Vpeak or 60Vdc.</p>
⚠ WARNING	
	<p>Operating of the Beckhoff Terminal <u>EL9260</u> [▶ 56] with Beckhoff Terminal <u>EL1702-0020</u></p> <p>Fuses have to be specified as 250Vac/6.3A/size 20x5.2mm as all of these parameters are critical for safety.</p>

Basic principles

UL certification according to UL508. Devices with this kind of certification are marked by this sign:



4.4 Installation on mounting rails

⚠ WARNING

Risk of electric shock and damage of device!

Bring the bus terminal system into a safe, powered down state before starting installation, disassembly or wiring of the bus terminals!

The Bus Terminal system and is designed for mounting in a control cabinet or terminal box.

Assembly

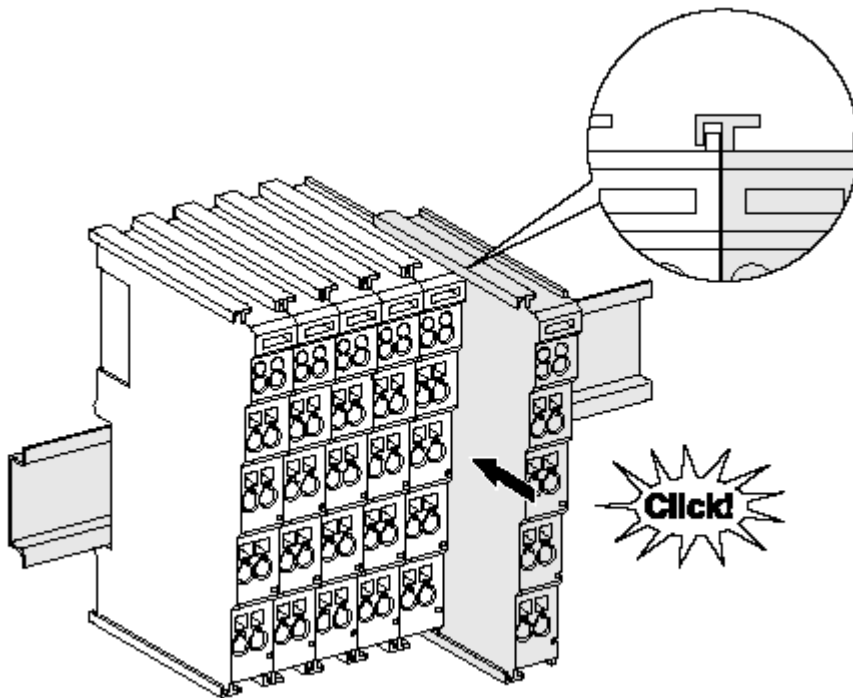

Fig. 56: Attaching on mounting rail

The bus coupler and bus terminals are attached to commercially available 35 mm mounting rails (DIN rails according to EN 60715) by applying slight pressure:

1. First attach the fieldbus coupler to the mounting rail.
2. The bus terminals are now attached on the right-hand side of the fieldbus coupler. Join the components with tongue and groove and push the terminals against the mounting rail, until the lock clicks onto the mounting rail.

If the terminals are clipped onto the mounting rail first and then pushed together without tongue and groove, the connection will not be operational! When correctly assembled, no significant gap should be visible between the housings.

i Fixing of mounting rails

The locking mechanism of the terminals and couplers extends to the profile of the mounting rail. At the installation, the locking mechanism of the components must not come into conflict with the fixing bolts of the mounting rail. To mount the mounting rails with a height of 7.5 mm under the terminals and couplers, you should use flat mounting connections (e.g. countersunk screws or blind rivets).

Disassembly

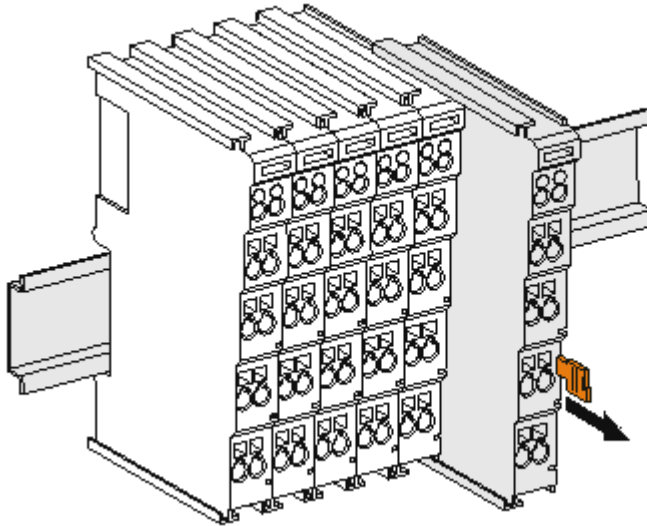

Fig. 57: Disassembling of terminal

Each terminal is secured by a lock on the mounting rail, which must be released for disassembly:

1. Pull the terminal by its orange-colored lugs approximately 1 cm away from the mounting rail. In doing so for this terminal the mounting rail lock is released automatically and you can pull the terminal out of the bus terminal block easily without excessive force.
2. Grasp the released terminal with thumb and index finger simultaneous at the upper and lower grooved housing surfaces and pull the terminal out of the bus terminal block.

Connections within a bus terminal block

The electric connections between the Bus Coupler and the Bus Terminals are automatically realized by joining the components:

- The six spring contacts of the K-Bus/E-Bus deal with the transfer of the data and the supply of the Bus Terminal electronics.
- The power contacts deal with the supply for the field electronics and thus represent a supply rail within the bus terminal block. The power contacts are supplied via terminals on the Bus Coupler (up to 24 V) or for higher voltages via power feed terminals.

● Power Contacts

i During the design of a bus terminal block, the pin assignment of the individual Bus Terminals must be taken account of, since some types (e.g. analog Bus Terminals or digital 4-channel Bus Terminals) do not or not fully loop through the power contacts. Power Feed Terminals (KL91xx, KL92xx or EL91xx, EL92xx) interrupt the power contacts and thus represent the start of a new supply rail.

PE power contact

The power contact labeled PE can be used as a protective earth. For safety reasons this contact mates first when plugging together, and can ground short-circuit currents of up to 125 A.

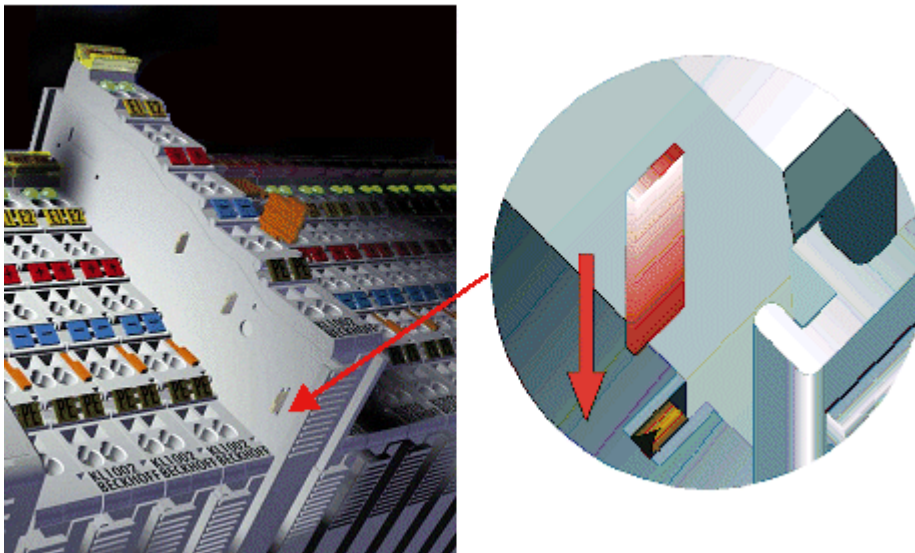

Fig. 58: Power contact on left side

NOTICE

Possible damage of the device

Note that, for reasons of electromagnetic compatibility, the PE contacts are capacitatively coupled to the mounting rail. This may lead to incorrect results during insulation testing or to damage on the terminal (e.g. disruptive discharge to the PE line during insulation testing of a consumer with a nominal voltage of 230 V). For insulation testing, disconnect the PE supply line at the Bus Coupler or the Power Feed Terminal! In order to decouple further feed points for testing, these Power Feed Terminals can be released and pulled at least 10 mm from the group of terminals.

⚠ WARNING

Risk of electric shock!

The PE power contact must not be used for other potentials!

4.5 Installation positions

NOTICE

Constraints regarding installation position and operating temperature range

Please refer to the technical data for a terminal to ascertain whether any restrictions regarding the installation position and/or the operating temperature range have been specified. When installing high power dissipation terminals ensure that an adequate spacing is maintained between other components above and below the terminal in order to guarantee adequate ventilation!

Optimum installation position (standard)

The optimum installation position requires the mounting rail to be installed horizontally and the connection surfaces of the EL/KL terminals to face forward (see Fig. *Recommended distances for standard installation position*). The terminals are ventilated from below, which enables optimum cooling of the electronics through convection. "From below" is relative to the acceleration of gravity.

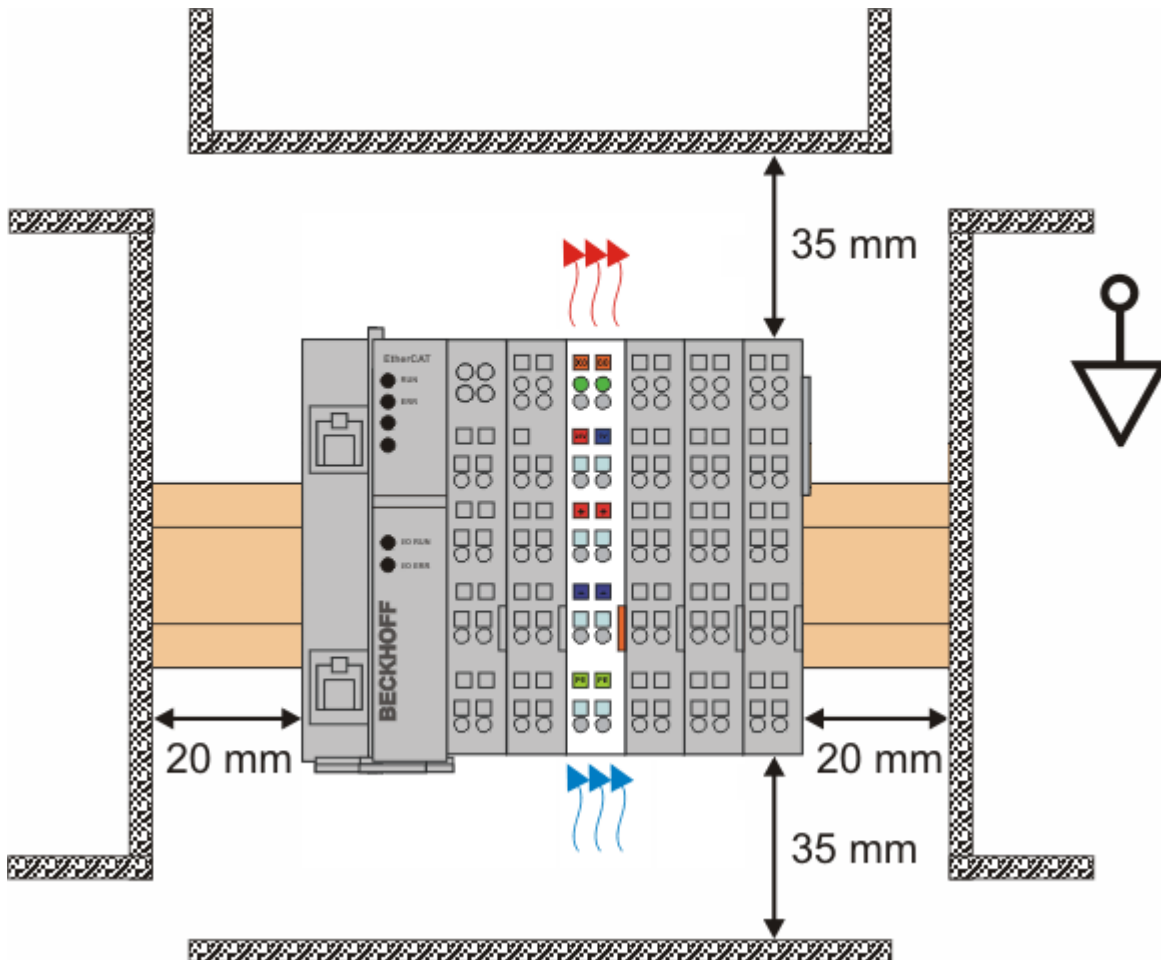

Fig. 59: Recommended distances for standard installation position

Compliance with the distances shown in Fig. *Recommended distances for standard installation position* is recommended.

Other installation positions

All other installation positions are characterized by different spatial arrangement of the mounting rail - see Fig *Other installation positions*.

The minimum distances to ambient specified above also apply to these installation positions.

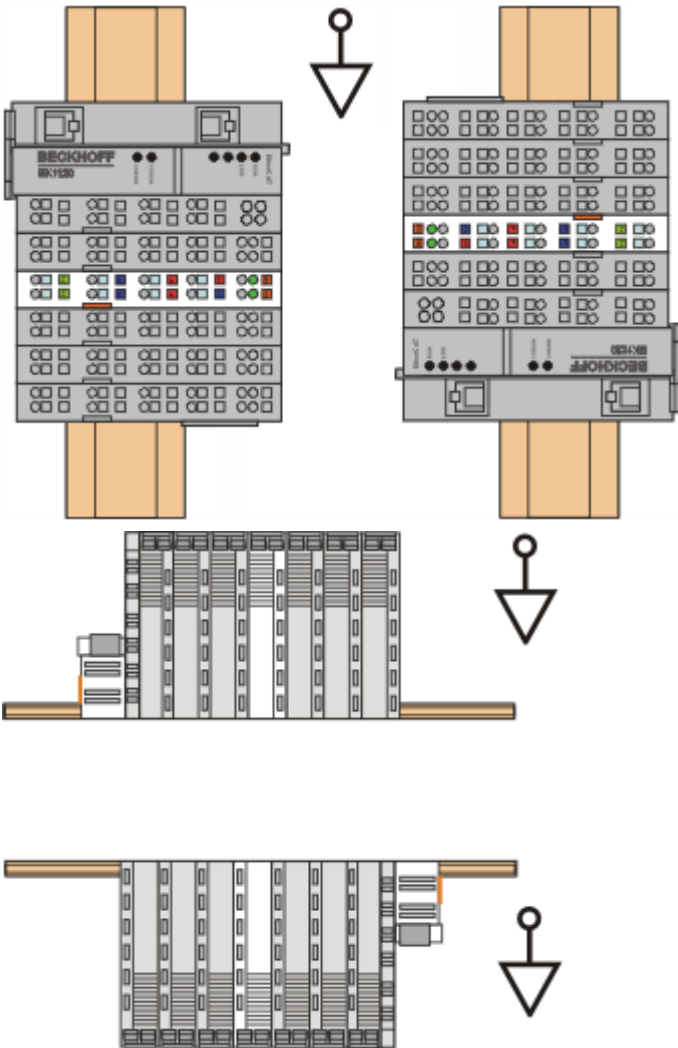

Fig. 60: Other installation positions

4.6 Installation instructions for enhanced mechanical load capacity

⚠ WARNING

Risk of injury through electric shock and damage to the device!

Bring the Bus Terminal system into a safe, de-energized state before starting mounting, disassembly or wiring of the Bus Terminals!

Additional checks

The terminals have undergone the following additional tests:

Verification	Explanation
Vibration	10 frequency runs in 3 axes
	6 Hz < f < 60 Hz displacement 0.35 mm, constant amplitude
	60.1 Hz < f < 500 Hz acceleration 5 g, constant amplitude
Shocks	1000 shocks in each direction, in 3 axes
	25 g, 6 ms

Additional installation instructions

For terminals with enhanced mechanical load capacity, the following additional installation instructions apply:

- The enhanced mechanical load capacity is valid for all permissible installation positions
- Use a mounting rail according to EN 60715 TH35-15
- Fix the terminal segment on both sides of the mounting rail with a mechanical fixture, e.g. an earth terminal or reinforced end clamp
- The maximum total extension of the terminal segment (without coupler) is:
64 terminals (12 mm mounting with) or 32 terminals (24 mm mounting with)
- Avoid deformation, twisting, crushing and bending of the mounting rail during edging and installation of the rail
- The mounting points of the mounting rail must be set at 5 cm intervals
- Use countersunk head screws to fasten the mounting rail
- The free length between the strain relief and the wire connection should be kept as short as possible. A distance of approx. 10 cm should be maintained to the cable duct.

4.7 Positioning of passive Terminals

i **Hint for positioning of passive terminals in the bus terminal block**

EtherCAT Terminals (ELxxxx / ESxxxx), which do not take an active part in data transfer within the bus terminal block are so called passive terminals. The passive terminals have no current consumption out of the E-Bus.

To ensure an optimal data transfer, you must not directly string together more than two passive terminals!

Examples for positioning of passive terminals (highlighted)

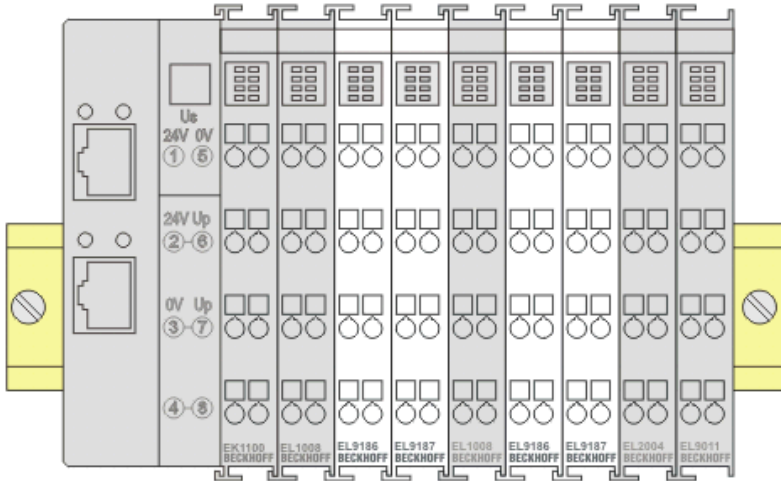

Fig. 61: Correct positioning

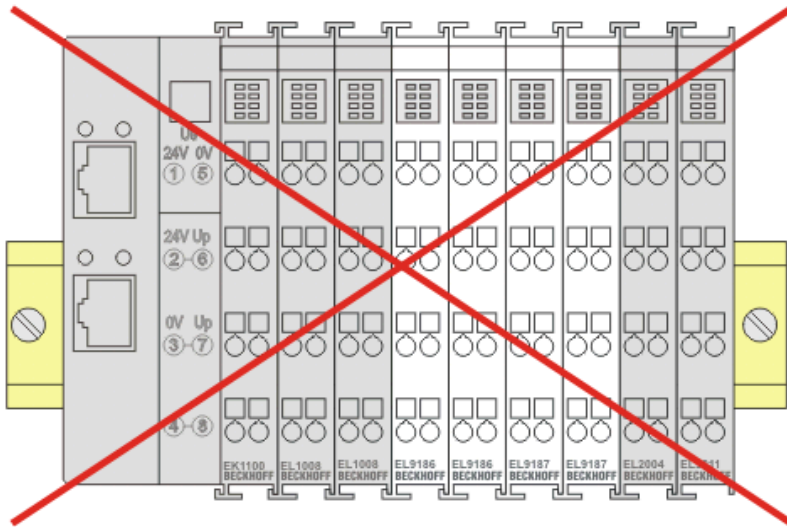

Fig. 62: Incorrect positioning

4.8 Note - Power supply

WARNING

Power supply from SELV/PELV power supply unit!

SELV/PELV circuits (Safety Extra Low Voltage, Protective Extra Low Voltage) according to IEC 61010-2-201 must be used to supply this device.

Notes:

- SELV/PELV circuits may give rise to further requirements from standards such as IEC 60204-1 et al, for example with regard to cable spacing and insulation.
- A SELV (Safety Extra Low Voltage) supply provides safe electrical isolation and limitation of the voltage without a connection to the protective conductor,
a PELV (Protective Extra Low Voltage) supply also requires a safe connection to the protective conductor.

4.9 Connection

4.9.1 Connection system

⚠ WARNING

Risk of electric shock and damage of device!

Bring the bus terminal system into a safe, powered down state before starting installation, disassembly or wiring of the bus terminals!

Overview

The bus terminal system offers different connection options for optimum adaptation to the respective application:

- The terminals of ELxxxx and KLxxxx series with standard wiring include electronics and connection level in a single enclosure.
- The terminals of ESxxxx and KSxxxx series feature a pluggable connection level and enable steady wiring while replacing.
- The High Density Terminals (HD Terminals) include electronics and connection level in a single enclosure and have advanced packaging density.

Standard wiring (ELxxxx / KLxxxx)



Fig. 63: Standard wiring

The terminals of ELxxxx and KLxxxx series have been tried and tested for years. They feature integrated screwless spring force technology for fast and simple assembly.

Pluggable wiring (ESxxxx / KSxxxx)



Fig. 64: Pluggable wiring

The terminals of ESxxxx and KSxxxx series feature a pluggable connection level. The assembly and wiring procedure is the same as for the ELxxxx and KLxxxx series. The pluggable connection level enables the complete wiring to be removed as a plug connector from the top of the housing for servicing. The lower section can be removed from the terminal block by pulling the unlocking tab. Insert the new component and plug in the connector with the wiring. This reduces the installation time and eliminates the risk of wires being mixed up.

The familiar dimensions of the terminal only had to be changed slightly. The new connector adds about 3 mm. The maximum height of the terminal remains unchanged.

A tab for strain relief of the cable simplifies assembly in many applications and prevents tangling of individual connection wires when the connector is removed.

Conductor cross sections between 0.08 mm² and 2.5 mm² can continue to be used with the proven spring force technology.

The overview and nomenclature of the product names for ESxxxx and KSxxxx series has been retained as known from ELxxxx and KLxxxx series.

High Density Terminals (HD Terminals)



Fig. 65: High Density Terminals

The terminals from these series with 16 terminal points are distinguished by a particularly compact design, as the packaging density is twice as large as that of the standard 12 mm bus terminals. Massive conductors and conductors with a wire end sleeve can be inserted directly into the spring loaded terminal point without tools.

● **Wiring HD Terminals**

i The High Density Terminals of the ELx8xx and KLx8xx series doesn't support pluggable wiring.

Ultrasonically “bonded” (ultrasonically welded) conductors

● **Ultrasonically “bonded” conductors**

i It is also possible to connect the Standard and High Density Terminals with ultrasonically “bonded” (ultrasonically welded) conductors. In this case, please note the tables concerning the wire-size width [[▶ 103](#)]!

4.9.2 Wiring

⚠ WARNING

Risk of electric shock and damage of device!

Bring the bus terminal system into a safe, powered down state before starting installation, disassembly or wiring of the bus terminals!

Terminals for standard wiring ELxxxx/KLxxxx and for pluggable wiring ESxxxx/KSxxxx

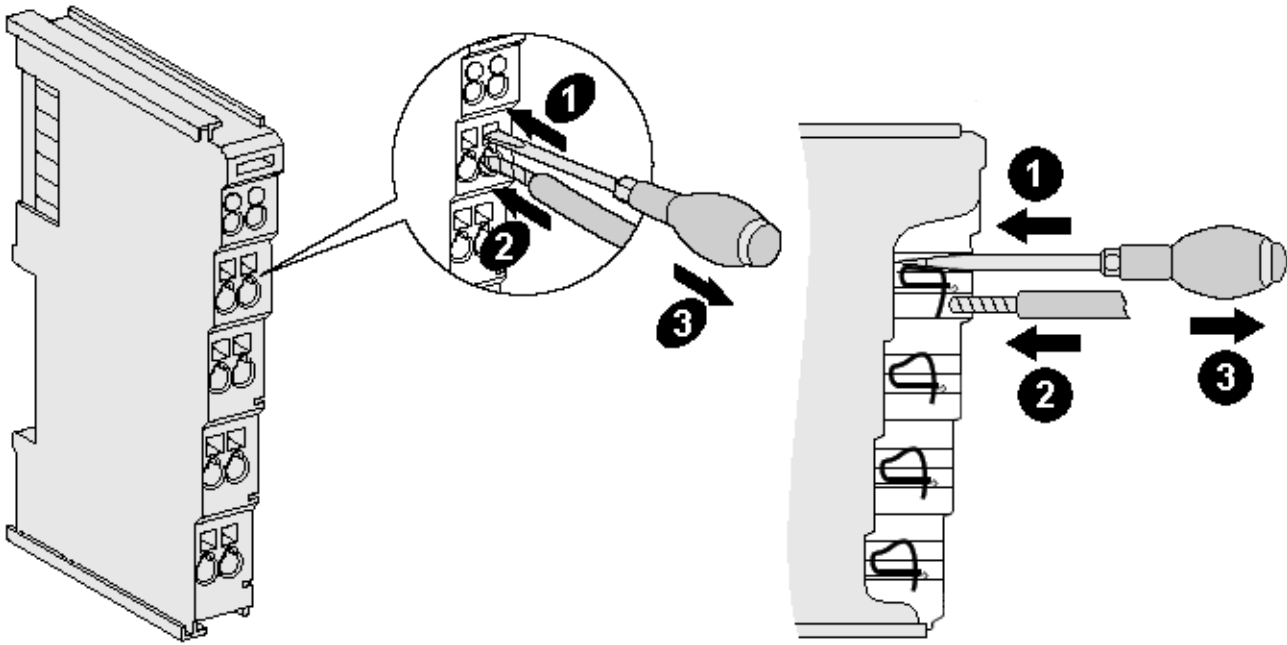

Fig. 66: Connecting a cable on a terminal point

Up to eight terminal points enable the connection of solid or finely stranded cables to the bus terminal. The terminal points are implemented in spring force technology. Connect the cables as follows:

1. Open a terminal point by pushing a screwdriver straight against the stop into the square opening above the terminal point. Do not turn the screwdriver or move it alternately (don't toggle).
2. The wire can now be inserted into the round terminal opening without any force.
3. The terminal point closes automatically when the pressure is released, holding the wire securely and permanently.

See the following table for the suitable wire size width.

Terminal housing	ELxxxx, KLxxxx	ESxxxx, KSxxxx
Wire size width (single core wires)	0.08 ... 2.5 mm ²	0.08 ... 2.5 mm ²
Wire size width (fine-wire conductors)	0.08 ... 2.5 mm ²	0.08 ... 2.5 mm ²
Wire size width (conductors with a wire end sleeve)	0.14 ... 1.5 mm ²	0.14 ... 1.5 mm ²
Wire stripping length	8 ... 9 mm	9 ... 10 mm

High Density Terminals ([HD Terminals](#) [▶ 102]) with 16 terminal points

The conductors of the HD Terminals are connected without tools for single-wire conductors using the direct plug-in technique, i.e. after stripping the wire is simply plugged into the terminal point. The cables are released, as usual, using the contact release with the aid of a screwdriver. See the following table for the suitable wire size width.

Terminal housing	High Density Housing
Wire size width (single core wires)	0.08 ... 1.5 mm ²
Wire size width (fine-wire conductors)	0.25 ... 1.5 mm ²
Wire size width (conductors with a wire end sleeve)	0.14 ... 0.75 mm ²
Wire size width (ultrasonically "bonded" conductors)	only 1.5 mm ² (see notice [▶ 102])
Wire stripping length	8 ... 9 mm

4.9.3 Shielding



Shielding

Encoder, analog sensors and actuators should always be connected with shielded, twisted paired wires.

4.10 Disposal



Products marked with a crossed-out wheeled bin shall not be discarded with the normal waste stream. The device is considered as waste electrical and electronic equipment. The national regulations for the disposal of waste electrical and electronic equipment must be observed.

5 TwinCAT System Manager

5.1 Configuration with TwinCAT System Manager - passive terminals

EL9011, EL9070, EL9080;
EL9100, EL9150, EL9181, EL9182, EL9183, EL9184, EL9186, EL9187, EL9188, EL9189, EL9190;
EL9200, EL9250, EL9290;
EL9400;
EL9540, EL9550;
EL9570

There are no address or configuration settings necessary for the mentioned passive terminals.

6 Appendix

6.1 EtherCAT AL Status Codes

For detailed information please refer to the [EtherCAT system description](#).

6.2 Firmware compatibility - passive terminals

The [passive terminals](#) [▶ 99] ELxxxx terminal series have no firmware to update.

6.3 Support and Service

Beckhoff and their partners around the world offer comprehensive support and service, making available fast and competent assistance with all questions related to Beckhoff products and system solutions.

Beckhoff's branch offices and representatives

Please contact your Beckhoff branch office or representative for local support and service on Beckhoff products!

The addresses of Beckhoff's branch offices and representatives round the world can be found on her internet pages: www.beckhoff.com

You will also find further documentation for Beckhoff components there.

Support

The Beckhoff Support offers you comprehensive technical assistance, helping you not only with the application of individual Beckhoff products, but also with other, wide-ranging services:

- support
- design, programming and commissioning of complex automation systems
- and extensive training program for Beckhoff system components

Hotline: +49 5246 963 157
e-mail: support@beckhoff.com
web: www.beckhoff.com/support

Service

The Beckhoff Service Center supports you in all matters of after-sales service:

- on-site service
- repair service
- spare parts service
- hotline service

Hotline: +49 5246 963 460
e-mail: service@beckhoff.com
web: www.beckhoff.com/service

Headquarters Germany

Beckhoff Automation GmbH & Co. KG

Hülshorstweg 20
33415 Verl
Germany

Phone: +49 5246 963 0
e-mail: info@beckhoff.com
web: www.beckhoff.com

More Information:
www.beckhoff.com/EL9xxx

Beckhoff Automation GmbH & Co. KG
Hülshorstweg 20
33415 Verl
Germany
Phone: +49 5246 9630
info@beckhoff.com
www.beckhoff.com

